

# Electronics Repair Manual

- **Electronic Repair Basics**
- **Tools and Test Equipment**
- **Troubleshooting and Maintenance**

- **Specific Repair Instructions**
  - **Schematic Diagrams**
- **Component/Manufacturer Indices**





# Electronics Repair Manual

- Electronics Repair Basics
- Tools and Test Equipment
- Troubleshooting and Maintenance
- Specific Repair Instructions
  - Schematic Diagrams
- Component/Manufacturer Indices

Editor

---

Gene B. Williams

© WEKA Publishing, Inc., 1993

New York • Munich • Zurich • Paris  
Milan • Amsterdam • Vienna

The publisher shall not be liable to the purchaser or any other person or entity with respect to any liability, loss or damage caused or alleged to be caused directly or indirectly by this book.

---

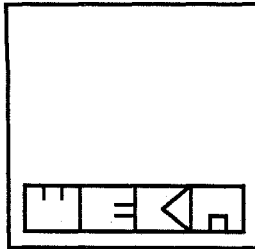
When attributed as a source, the named manufacturer reserves all rights to the information presented. **WEKA Publishing** reserves the rights to the format in which such information is presented in the *Electronics Repair Manual*. For the sum of the other material in the book, all rights reserved by **WEKA Publishing**. No part of this publication may be reproduced in any form or by any means—graphic, electronic or mechanical, including photocopying, recording, taping or information storage and retrieval systems—without the permission of the publisher.

---

**WEKA Publishing**  
97 Indian Field Rd  
Greenwich, CT 06830  
(203) 622-4177  
FAX (203) 622-4187

A member of the international WEKA Publishing Group  
New York • Munich • Zurich • Paris • Milan • Amsterdam • Vienna

© WEKA Publishing, Inc., 1993  
ISBN: 0-929321-06-5



**WEKA Publishing, Inc**  
97 Indian Field Road  
Greenwich, CT 06830  
Phone: 203-622-4177  
Toll-free: 1-800-222-WEKA  
Fax: 203-622-4187

---

USA • Germany • Switzerland • France • Italy • Netherlands • Austria • Belgium

Dear Subscriber,

As Product Manager for the **Electronics Repair Manual**, I'd like to welcome you personally to what I think is the most useful reference source for electronics repair.

Your manual occupies a unique place in today's array of electronics books and magazines; unique simply because it covers and explores all of the areas which are of interest to professionals and hobbyists. From repairing audio and video equipment, to computers, to household appliances and automobile electronics, this manual is packed with valuable information, references, and step-by-step instructions—things you want and need to know.

### **Repair All Kinds of Electronics Yourself**

Radio receivers, television sets, VCRs, camcorders, personal computers and peripherals, CD players — whatever your repair job, you'll have comprehensive information within easy reach. For each device covered you'll find:

- fundamentals of operation
- necessary tools and test equipment
- preventive maintenance
- troubleshooting and repair instructions

### **Use Universal Repair Instructions for General Troubleshooting**

Universal repair instructions are provided that apply to entire groups of equipment. You'll find general approaches on how to locate the faulty parts of your device and how to repair it. You can be working on one of the hundreds of VCR models in use today and have valid repair instructions at your fingertips.

### **Profit from Model-Specific Repair Instructions**

Specific repair instructions show you step-by-step troubleshooting and repair for particular models. This in-depth information is illustrated with drawings and pictures, accompanied by checklists and diagrams. As a beginner or professional, this section offers you a treasure of tips and hints that will increase your success with repairing all kinds of electronics equipment.

### **Now You Have a Complete Reference Source at Your Fingertips**

In addition to universal repair instructions and model-specific repair instructions, your manual provides you with schematics, valuable data tables on electronic components, an in-depth section on tools and test equipment, and lists of suppliers and manufacturers.

### **Your Manual Continues to Grow in Size and Value**

Your quarterly updates to the **Electronics Repair Manual** provide you with an ever-expanding source of repair information. You'll keep up with technological developments and increase your productivity through additional hands-on projects.

### **Shape Your Supplements**

Use the enclosed questionnaire to help us select the devices and topics for future updates. What devices are you interested in? Do you like more universal or more model-specific repair instructions? What kind of component indices would be of help to you?

In a sense, you become a member of our editorial team. You help us to make the manual your manual — to make it what you want it to be.

I hope you'll enjoy your edition of the **Electronics Repair Manual!** Any comments and suggestions you may have regarding this book and the updates are welcomed. We look forward to hearing from you.

Sincerely,



Christopher B. Smith  
Product Manager for Electronics Publications

**P.S.:** If you like to save time and money, please feel free to give our Customer Service Department a call in order to take advantage of our special subscription offer. You'll be saving shipping and handling for a whole year and you'll receive an additional binder for free! So why don't call today! Our toll-free number is **1-800-622-WEKA**.

# Electronics Repair Manual - Questionnaire

**1 How interesting are the different sections of the manual to you?**

(please indicate: 1 = highest interest; 5 = lowest interest)

	1	2	3	4	5
Electronics Repair Basics	<input type="checkbox"/>	<input type="checkbox"/>	<input type="checkbox"/>	<input type="checkbox"/>	<input type="checkbox"/>
Tools and Test Equipment	<input type="checkbox"/>	<input type="checkbox"/>	<input type="checkbox"/>	<input type="checkbox"/>	<input type="checkbox"/>
Video	<input type="checkbox"/>	<input type="checkbox"/>	<input type="checkbox"/>	<input type="checkbox"/>	<input type="checkbox"/>
Television	<input type="checkbox"/>	<input type="checkbox"/>	<input type="checkbox"/>	<input type="checkbox"/>	<input type="checkbox"/>
Audio	<input type="checkbox"/>	<input type="checkbox"/>	<input type="checkbox"/>	<input type="checkbox"/>	<input type="checkbox"/>
Automobile Electronics	<input type="checkbox"/>	<input type="checkbox"/>	<input type="checkbox"/>	<input type="checkbox"/>	<input type="checkbox"/>
Computer Equipment	<input type="checkbox"/>	<input type="checkbox"/>	<input type="checkbox"/>	<input type="checkbox"/>	<input type="checkbox"/>
Home Appliances	<input type="checkbox"/>	<input type="checkbox"/>	<input type="checkbox"/>	<input type="checkbox"/>	<input type="checkbox"/>
Reference Materials:					
- Addresses	<input type="checkbox"/>	<input type="checkbox"/>	<input type="checkbox"/>	<input type="checkbox"/>	<input type="checkbox"/>
- Indices	<input type="checkbox"/>	<input type="checkbox"/>	<input type="checkbox"/>	<input type="checkbox"/>	<input type="checkbox"/>
- Schematics	<input type="checkbox"/>	<input type="checkbox"/>	<input type="checkbox"/>	<input type="checkbox"/>	<input type="checkbox"/>

Name: \_\_\_\_\_

Address: \_\_\_\_\_

City: \_\_\_\_\_ State: \_\_\_\_\_ ZIP: \_\_\_\_\_

Phone Number: (\_\_\_\_) \_\_\_\_\_

**2 How important is our toll-free hotline service to you?**

(1 = very important; 5 = not important)

1	2	3	4	5
<input type="checkbox"/>	<input type="checkbox"/>	<input type="checkbox"/>	<input type="checkbox"/>	<input type="checkbox"/>

**3 Which devices would you like to see covered in future updates?**

Please indicate whether you are interested in: a) maintenance; b) general troubleshooting techniques and repair instructions; c) troubleshooting certain problems (please indicate the problem) d) case studies to various models [(please indicate the manufacturer and model(s)); e) schematic diagrams [(please indicate manufacturer and model(s))]. Please note the most important manufacturers for each area.

	a) Maintenance	b) General trouble- shooting/repair	c) Troubleshooting certain problems	d) Case studies	e) Schematic diagrams
<b>Video</b>					
<input type="checkbox"/> VCRs:VHS	<input type="checkbox"/>	<input type="checkbox"/>	<input type="checkbox"/> _____	<input type="checkbox"/> _____	<input type="checkbox"/> _____
SVHS	<input type="checkbox"/>	<input type="checkbox"/>	<input type="checkbox"/> _____	<input type="checkbox"/> _____	<input type="checkbox"/> _____
<input type="checkbox"/> Camcorders:					
VHS	<input type="checkbox"/>	<input type="checkbox"/>	<input type="checkbox"/> _____	<input type="checkbox"/> _____	<input type="checkbox"/> _____
SVHS	<input type="checkbox"/>	<input type="checkbox"/>	<input type="checkbox"/> _____	<input type="checkbox"/> _____	<input type="checkbox"/> _____
VHS-C	<input type="checkbox"/>	<input type="checkbox"/>	<input type="checkbox"/> _____	<input type="checkbox"/> _____	<input type="checkbox"/> _____
SVHS-C	<input type="checkbox"/>	<input type="checkbox"/>	<input type="checkbox"/> _____	<input type="checkbox"/> _____	<input type="checkbox"/> _____
8 mm	<input type="checkbox"/>	<input type="checkbox"/>	<input type="checkbox"/> _____	<input type="checkbox"/> _____	<input type="checkbox"/> _____
Hi-8	<input type="checkbox"/>	<input type="checkbox"/>	<input type="checkbox"/> _____	<input type="checkbox"/> _____	<input type="checkbox"/> _____
Beta	<input type="checkbox"/>	<input type="checkbox"/>	<input type="checkbox"/> _____	<input type="checkbox"/> _____	<input type="checkbox"/> _____
<input type="checkbox"/> Laser Disc Player	<input type="checkbox"/>	<input type="checkbox"/>	<input type="checkbox"/> _____	<input type="checkbox"/> _____	<input type="checkbox"/> _____
<input type="checkbox"/> Cameras	<input type="checkbox"/>	<input type="checkbox"/>	<input type="checkbox"/> _____	<input type="checkbox"/> _____	<input type="checkbox"/> _____
Other: _____	<input type="checkbox"/>	<input type="checkbox"/>	<input type="checkbox"/> _____	<input type="checkbox"/> _____	<input type="checkbox"/> _____

Most important manufacturer(s) \_\_\_\_\_

**Audio**

<input type="checkbox"/> Microphone	<input type="checkbox"/>	<input type="checkbox"/>	<input type="checkbox"/> _____	<input type="checkbox"/> _____	<input type="checkbox"/> _____
<input type="checkbox"/> Tape Recorder	<input type="checkbox"/>	<input type="checkbox"/>	<input type="checkbox"/> _____	<input type="checkbox"/> _____	<input type="checkbox"/> _____
<input type="checkbox"/> Walkman	<input type="checkbox"/>	<input type="checkbox"/>	<input type="checkbox"/> _____	<input type="checkbox"/> _____	<input type="checkbox"/> _____
<input type="checkbox"/> Turntable	<input type="checkbox"/>	<input type="checkbox"/>	<input type="checkbox"/> _____	<input type="checkbox"/> _____	<input type="checkbox"/> _____
<input type="checkbox"/> Amplifier	<input type="checkbox"/>	<input type="checkbox"/>	<input type="checkbox"/> _____	<input type="checkbox"/> _____	<input type="checkbox"/> _____
<input type="checkbox"/> CD Player	<input type="checkbox"/>	<input type="checkbox"/>	<input type="checkbox"/> _____	<input type="checkbox"/> _____	<input type="checkbox"/> _____
<input type="checkbox"/> Loudspeaker	<input type="checkbox"/>	<input type="checkbox"/>	<input type="checkbox"/> _____	<input type="checkbox"/> _____	<input type="checkbox"/> _____
<input type="checkbox"/> Crossover Systems	<input type="checkbox"/>	<input type="checkbox"/>	<input type="checkbox"/> _____	<input type="checkbox"/> _____	<input type="checkbox"/> _____
Other: _____	<input type="checkbox"/>	<input type="checkbox"/>	<input type="checkbox"/> _____	<input type="checkbox"/> _____	<input type="checkbox"/> _____

Most important manufacturer(s) \_\_\_\_\_

**Automobile Electronics**

<input type="checkbox"/> Air Conditioning/ temperature control	<input type="checkbox"/>	<input type="checkbox"/>	<input type="checkbox"/> _____	<input type="checkbox"/> _____	<input type="checkbox"/> _____
<input type="checkbox"/> Ignition/starter	<input type="checkbox"/>	<input type="checkbox"/>	<input type="checkbox"/> _____	<input type="checkbox"/> _____	<input type="checkbox"/> _____
<input type="checkbox"/> Electric sunroof					
<input type="checkbox"/> Windows/door lock	<input type="checkbox"/>	<input type="checkbox"/>	<input type="checkbox"/> _____	<input type="checkbox"/> _____	<input type="checkbox"/> _____
<input type="checkbox"/> Fuel control	<input type="checkbox"/>	<input type="checkbox"/>	<input type="checkbox"/> _____	<input type="checkbox"/> _____	<input type="checkbox"/> _____
<input type="checkbox"/> Speed control	<input type="checkbox"/>	<input type="checkbox"/>	<input type="checkbox"/> _____	<input type="checkbox"/> _____	<input type="checkbox"/> _____
<input type="checkbox"/> Travel computer	<input type="checkbox"/>	<input type="checkbox"/>	<input type="checkbox"/> _____	<input type="checkbox"/> _____	<input type="checkbox"/> _____

	a) Maintenance	b) General trouble- shooting/repair	c) Troubleshooting certain problems	d) Case studies	e) Schematic diagrams
<b>Automobile</b>					
<b>Electronics(cont'd)</b>					
<input type="checkbox"/> Alternator	<input type="checkbox"/>	<input type="checkbox"/>	<input type="checkbox"/>	<input type="checkbox"/>	<input type="checkbox"/>
Other: _____	<input type="checkbox"/>	<input type="checkbox"/>	<input type="checkbox"/>	<input type="checkbox"/>	<input type="checkbox"/>
Most important manufacturer(s) _____					
<b>Computer Equipment</b>					
<input type="checkbox"/> Personal Computer	<input type="checkbox"/>	<input type="checkbox"/>	<input type="checkbox"/>	<input type="checkbox"/>	<input type="checkbox"/>
<input type="checkbox"/> Mini-Microcomputer	<input type="checkbox"/>	<input type="checkbox"/>	<input type="checkbox"/>	<input type="checkbox"/>	<input type="checkbox"/>
<input type="checkbox"/> Computer Boards	<input type="checkbox"/>	<input type="checkbox"/>	<input type="checkbox"/>	<input type="checkbox"/>	<input type="checkbox"/>
<input type="checkbox"/> Ports	<input type="checkbox"/>	<input type="checkbox"/>	<input type="checkbox"/>	<input type="checkbox"/>	<input type="checkbox"/>
<input type="checkbox"/> Hard Drive	<input type="checkbox"/>	<input type="checkbox"/>	<input type="checkbox"/>	<input type="checkbox"/>	<input type="checkbox"/>
<input type="checkbox"/> CD-ROM	<input type="checkbox"/>	<input type="checkbox"/>	<input type="checkbox"/>	<input type="checkbox"/>	<input type="checkbox"/>
<input type="checkbox"/> Laser Printer	<input type="checkbox"/>	<input type="checkbox"/>	<input type="checkbox"/>	<input type="checkbox"/>	<input type="checkbox"/>
<input type="checkbox"/> Dot Matrix Printer	<input type="checkbox"/>	<input type="checkbox"/>	<input type="checkbox"/>	<input type="checkbox"/>	<input type="checkbox"/>
<input type="checkbox"/> Scanner	<input type="checkbox"/>	<input type="checkbox"/>	<input type="checkbox"/>	<input type="checkbox"/>	<input type="checkbox"/>
<input type="checkbox"/> Monitor	<input type="checkbox"/>	<input type="checkbox"/>	<input type="checkbox"/>	<input type="checkbox"/>	<input type="checkbox"/>
<input type="checkbox"/> Mouse	<input type="checkbox"/>	<input type="checkbox"/>	<input type="checkbox"/>	<input type="checkbox"/>	<input type="checkbox"/>
Other: _____	<input type="checkbox"/>	<input type="checkbox"/>	<input type="checkbox"/>	<input type="checkbox"/>	<input type="checkbox"/>
Most important manufacturer(s) _____					
<b>Home Appliances</b>					
<input type="checkbox"/> Refrigerator/Freezer	<input type="checkbox"/>	<input type="checkbox"/>	<input type="checkbox"/>	<input type="checkbox"/>	<input type="checkbox"/>
<input type="checkbox"/> Dish Washer	<input type="checkbox"/>	<input type="checkbox"/>	<input type="checkbox"/>	<input type="checkbox"/>	<input type="checkbox"/>
<input type="checkbox"/> Washer/Dryer	<input type="checkbox"/>	<input type="checkbox"/>	<input type="checkbox"/>	<input type="checkbox"/>	<input type="checkbox"/>
<input type="checkbox"/> Sewing Machine	<input type="checkbox"/>	<input type="checkbox"/>	<input type="checkbox"/>	<input type="checkbox"/>	<input type="checkbox"/>
<input type="checkbox"/> Lawn Mower	<input type="checkbox"/>	<input type="checkbox"/>	<input type="checkbox"/>	<input type="checkbox"/>	<input type="checkbox"/>
<input type="checkbox"/> Dehumidifier	<input type="checkbox"/>	<input type="checkbox"/>	<input type="checkbox"/>	<input type="checkbox"/>	<input type="checkbox"/>
<input type="checkbox"/> Air Conditioner	<input type="checkbox"/>	<input type="checkbox"/>	<input type="checkbox"/>	<input type="checkbox"/>	<input type="checkbox"/>
<input type="checkbox"/> Garage-door Opener	<input type="checkbox"/>	<input type="checkbox"/>	<input type="checkbox"/>	<input type="checkbox"/>	<input type="checkbox"/>
Other: _____	<input type="checkbox"/>	<input type="checkbox"/>	<input type="checkbox"/>	<input type="checkbox"/>	<input type="checkbox"/>
Most important manufacturer(s) _____					
<b>Miscellaneous (please note below)</b>					
_____	<input type="checkbox"/>	<input type="checkbox"/>	<input type="checkbox"/>	<input type="checkbox"/>	<input type="checkbox"/>
_____	<input type="checkbox"/>	<input type="checkbox"/>	<input type="checkbox"/>	<input type="checkbox"/>	<input type="checkbox"/>
_____	<input type="checkbox"/>	<input type="checkbox"/>	<input type="checkbox"/>	<input type="checkbox"/>	<input type="checkbox"/>

<p><b>4 Which specialized test equipment would you like to see covered?</b></p> <p>_____</p> <p>_____</p> <p>_____</p>	<p><b>5 Please mention any other topics that interest you:</b></p> <p>_____</p> <p>_____</p> <p>_____</p>
--	---

**6 Which kind of indices would you like to receive?**  
 [Please mention for each index, whether it should be a part number index (p), a functional index (f), or alternate source index (a)]

Diodes \_\_\_\_\_  Thyristors and Triacs \_\_\_\_\_  Transistors \_\_\_\_\_  Linear ICs such as \_\_\_\_\_

Microcontrollers \_\_\_\_\_  Microprocessors \_\_\_\_\_  Memories \_\_\_\_\_  Other Digital ICs \_\_\_\_\_

**7 I use the "Electronics Repair Manual" for**

Hobby only     Hobby and business     Business only

**8 As a repair technician, do you consider yourself:**

Beginner                       Advanced                       Professional

**9 Do you use a computer?**

No                       Yes

IBM Compatible     Macintosh     Other \_\_\_\_\_

Disk Drive:         5¼"         3½"

**10 Which other areas would you like to receive more detailed information about?**

Integrated Circuits     Data Acquisition     Electronics Projects

Electronics Basics     Home Office Computing     Other \_\_\_\_\_

**11 Which magazines do you read?**

Electronic Servicing & Technology     Popular Communications     Computer Craft     Popular Electronics     Radio Electronics

Viejo Publications                       Prentice Hall Electronics Book Club                       McGraw Hill Electronics Book Club

Other \_\_\_\_\_



---

# Section 1

## Table of Contents

---

**Section 1**

**Table of Contents**

**Section 2**

**Preface**

2/1	<i>Welcome</i>
2/2	<i>How to use Your Manual</i>
2/3	<i>Safety Procedures</i>

**Section 3**

**Electronic Repair Basics**

3/2	<i>Electronic Fundamentals</i>
3/2 - C	<i>Components</i>
3/2 - O	<i>Ohm's Law</i>
3/2 - PVC	<i>Power, Voltage, Current</i>
3/2 - QUS	<i>Quantities, Units, Symbols</i>
3/3	<i>Troubleshooting Techniques</i>
3/4	<i>Soldering/Desoldering</i>

**Section 4**

**Tools and Test Equipment**

4/1	<i>Tools for Repair</i>
4/2	<i>Basic Test Equipment</i>
4/3	<i>Advanced Test Equipment</i>
4/3 - DMM	<i>Digital Multimeter</i>
4/3 - FC	<i>Frequency Counter</i>
4/3 - LP	<i>Logic Probe</i>
4/3 - O	<i>Oscilloscope</i>
4/3 - SS	<i>Signal Sources</i>

**Section 5**

**Video**

5/Cam	<i>Camcorder</i>
5/Cam - A	<i>An Introduction</i>

**Section 5**

**Video (Continued)**

<b>5/Cam - F</b>	<i>Features</i>
<b>5/Cam - M</b>	<i>Maintenance</i>
<b>5/Cam - TE</b>	<i>Test Equipment</i>
<b>5/Cam - TR</b>	<i>Troubleshooting and Repair</i>
<b>5/Cam - VCS</b>	<i>Various Case Studies</i>
<b>5/VCR</b>	<i>Video Recorder</i>
<b>5/VCR - A</b>	<i>An Introduction</i>
<b>5/VCR - M</b>	<i>Maintenance</i>
<b>5/VCR - TE</b>	<i>Test Equipment</i>
<b>5/VCR - TR</b>	<i>Troubleshooting and Repair</i>
<b>5/VCR - VCS</b>	<i>Various Case Studies</i>

**Section 6**

**Television**

<b>6/TTV</b>	<i>Tube Television</i>
<b>6/TTV - A</b>	<i>An Introduction</i>
<b>6/TTV - TE</b>	<i>Test Equipment</i>
<b>6/TTV - TR</b>	<i>Troubleshooting and Repair</i>
<b>6/TTV - VCS</b>	<i>Various Case Studies</i>

**Section 7**

**Audio**

<b>7/A</b>	<i>Amplifier</i>
<b>7/A - A</b>	<i>An Introduction</i>
<b>7/A - TR</b>	<i>Troubleshooting and Repair</i>
<b>7/CD</b>	<i>CD Player</i>
<b>7/CD - A</b>	<i>An Introduction</i>
<b>7/CD - F</b>	<i>Features</i>
<b>7/CD - M</b>	<i>Maintenance</i>
<b>7/CD - TE</b>	<i>Test Equipment</i>
<b>7/CD - TR</b>	<i>Troubleshooting and Repair</i>
<b>7/R</b>	<i>Radio</i>
<b>7/R - A</b>	<i>An Introduction</i>
<b>7/R - F</b>	<i>Features</i>
<b>7/R - TR</b>	<i>Troubleshooting and Repair</i>

7/R *Receiver*  
 7/R - VCS *Various Case Studies*

7/T *Tuner*  
 7/T - VCS *Various Case Studies*

**Section 8 Automobile Electronics**

8/TE *Test Equipment*  
 8/TR *Troubleshooting and Repair*  
 8/TR - PS *Power Systems*  
 8/TR - ECM *Electronics Control Module*  
 8/TR - R *Radios*  
 8/TR - WS *Wiring Systems*  
 8/VCS *Various Case Studies*

**Section 9 Computer Equipment**

9/PC *Personal Computer*  
 9/PC - AM *Architecture of Microcomputers*  
 9/PC - C *Components*  
 9/PC - TE *Test Equipment*  
 9/PC - TR *Troubleshooting and Repair*  
 9/PC - VCS *Various Case Studies*

9/PR *Printer*  
 9/PR - A *An Introduction*  
 9/PR - M *Maintenance*  
 9/PR - TR *Troubleshooting and Repair*

**Section 10 Home Appliances**

10/A *An Introduction*  
 10/TR *Troubleshooting and Repair*  
 10/TR - A *An Introduction*  
 10/TR - A/C • R *Air Conditioners/Refrigerators*  
 10/TR - Co *Controls*  
 10/TR - ECM *Electronically Controlled Motors*  
 10/TR - T *Transformers*  
 10/TR - Th *Thermostats*

**Section 11**

**Miscellaneous Devices**

11/A	<i>An Introduction</i>
11/C	<i>Copier</i>
11/C - A	<i>An Introduction</i>
11/C - TR	<i>Troubleshooting and Repair</i>
11/F	<i>Fax Machine</i>
11/F - A	<i>An Introduction</i>
11/F - M	<i>Maintenance</i>
11/Tel	<i>Telephone</i>
11/Tel - A	<i>An Introduction</i>
11/Tel - TE	<i>Test Equipment</i>
11/Tel - TR	<i>Troubleshooting and Repair</i>

**Section 12**

**Reference Materials**

12/A	<i>Addresses</i>
12/I	<i>Indices</i>
12/S	<i>Schematics</i>

*(Note: For more detailed information see "Table of Contents" at the beginning of each section.)*

# Section 2

# Preface

---

## Table of Contents

- 2/1 *Welcome*
- 2/2 *How to Use Your Manual*
- 2/3 *Safety Procedures*

Section 2 • Preface

Table of  
Contents

---

---

---

---

**2/1**

Welcome

**2/1**  
**Welcome**

---

Welcome to the **Electronics Repair Manual!** This unique publication aims to provide the starter, as well as the professional, with clear and concise information on how to repair and maintain a wide range of electronic equipment.

Electronic equipment is complex, becoming more complex almost by the day. Our main objective is to ensure that the **Electronics Repair Manual** contains comprehensive, instructive and up-to-date material. To help us meet this goal, regular supplements to the book will provide you with additional troubleshooting and repair instructions, and technological updates.

In many cases, electronic equipment is delicate. Touch the wrong point with a probe, or use an improper cleaning material, and what was a simple job turns into a much more extensive one.

One home technician was trying to lubricate the tracking bars of a CD player with a spray can of WD-40. His intention was to cure the skipping that was occurring. Instead he ended up destroying the main circuit board and the laser's lens.

The **Electronics Repair Manual** will help you avoid mistakes, and give you plenty of repair tips and helpful advice.

Safety is the most important consideration when you are working with electronics. Always take precautions for your personal safety and the safety of the equipment on which you are working. Your manual includes a detailed safety article which outlines the steps you should take to avoid injury. The article also describes the measures to take in the event of an injury. It is imperative that you only tackle those faults which you understand.

Putting this another way, you should only attempt to repair an item of electronic equipment if you are fully confident that you understand what you are doing. Your **Electronics Repair Manual** will give you the information and confidence to tackle even complex problems. However, you should proceed cautiously at all times. WEKA Publishing is not responsible for any damage to health or equipment.

2/1

Welcome

Many of you will wish to specialize in particular areas of electronic maintenance. Others will wish to obtain a broader understanding of how to service electronic equipment. The **Electronics Repair Manual** is designed to satisfy both needs, providing introductory and advanced information on a variety of equipment.

We welcome responses from our readers. Your comments and suggestions help us to determine the contents of your future supplements. In a sense, you become a member of our editorial team. You help us to make the manual your manual — to make it what *you* want it to be.

Please use the attached questionnaire to let us know your interests. Tell us which devices, general references, indices, and technologies you would like to see covered in the future.

Whether you are a professional technician or an enthusiast working at home, we hope that you enjoy using the **Electronics Repair Manual** and wish you great success in all of your efforts!

Sincerely,



Gene Williams  
Editor, **Electronics Repair Manual**



**2/2**  
How to Use  
Your Manual

---

---

---

---

## 2/2 How to Use Your Manual

---

The **Electronics Repair Manual** contains 12 sections. Each section is further divided into chapters.

Sections 1 to 4 cover general information: **Table of Contents**, **Preface**, **Electronic Repair Basics**, and **Tools and Test Equipment**. The chapters in these sections are divided numerically, as you can see in the **Table of Contents** in Section 1.

Sections 5 to 11 contain repair information on specific types of electronic equipment, ranging from radio receivers and CD players to personal computers. The chapters in these sections are divided alphabetically.

For example, in “Section 5: Video” you can locate information on camcorders by looking for articles with “5/Cam” as a heading. When you need VCR information, look for “5/VCR”.

This structure will help you keep your manual organized as it grows in the future, allowing you to quickly locate needed information. Below are headings for different sections, showing how the sections are subdivided by numbers and/or alphabetically.

### Section 3 • Electronics Repair Basics

**3/2**  
Electronics  
Fundamentals

---

3/2 - C	Components
3/2 - C - PC	Passive Components
3/2 - C - PC - R	Resistors

---

### Section 5 • Video

**5/Cam**  
Camcorders

---

5/Cam - TR	Troubleshooting and Repair
5/Cam - TR - PS	Power Supplies

---

If you were interested in finding some basic information on resistors, the first place you would look would be “Section 3: **Electronic Repair Basics**”. Once in Section 3, you would locate “Chapter 2: **Electronic Fundamentals**”. In example 1, you will see “**3/2 Electronic Fundamentals**” in the black box.

Once you are in Chapter 2, you would look under the subhead “**Components**”, which is again divided into “**Active Components**” and “**Passive Components**”. Since resistors are passive components, you would look into this subheading.

As you can see in example 1, the subhead abbreviation for “**Components**” is **C**. The abbreviation for “**Passive Components**” is **PC**. Under the passive components subheading you will find the resistors article abbreviated as “**R**”. That is how the article got its chapter number “**3/2-C-PC-R**”.

The second example shows you how to locate information on troubleshooting camcorder power supplies.

- 1) You would look for camcorders in “Section 5: **Video**” under “**5/Cam**”.
- 2) All troubleshooting and repair information is abbreviated with “**TR**”.
- 3) A logical abbreviation for power supplies is “**PS**”.

The article you are looking for is labeled “**5/Cam-TR-PS**”. The following short list will show you some abbreviations that are used for each section:

<b>A:</b> An Introduction	<b>TE:</b> Test Equipment
<b>F:</b> Features	<b>TR:</b> Troubleshooting and Repair
<b>M:</b> Maintenance	<b>VCS:</b> Various Case Studies

All other abbreviations reflect the starting letters of the devices, parts, and components for which you are looking.

Section Twelve contains **Reference Materials**. This section is subdivided into “**12/A**” for **Addresses**, “**12/I**” for **Indices**, and “**12/S**” for **Schematics**.

We developed this alphabetical structure for your manual to allow you to easily insert future articles into the book, without messing up a numerical structure. As your manual grows, you will always have a reference that’s well organized, up-to-date and easy to use.

**2/3**  
Safety  
Procedures

## **2/3** **Safety Procedures**

---

Nothing is more important than safety. Trying to save a few dollars in repair costs isn't worth risking electrocution.

Safety can be divided into two overall parts—your personal safety and equipment safety. Even an expensive computer system can be replaced. Your health, or your life, cannot. The most basic rule of safety is that if you think safety is for the other guy, let the job be, too.

Keep in mind that it isn't just your own safety that is of concern. You are responsible for the safety of everyone around you as well. Even if you recognize that a certain spot inside the TV set you're working on is dangerous, someone else may not. You might understand that the soldering iron is on and hot—a small child coming into your work area might think that it looks like a fun toy.

Once you and those around you are safe, be sure that the equipment is safe. Once a technician who was probing a power supply during an initial diagnosis, touched the probe in a way that caused a short circuit, and blew out the power supply.

### **Warnings**

- *When replacing a fuse, use one that is an exact match. If the value is too small, the fuse is likely to blow; if the value is too high, the fuse can't provide protection.*
- *NEVER use a wire or other conductor to replace a fuse—not even temporarily.*
- *When possible, test and diagnose with the power off and the unit unplugged.*
- *Don't assume an unplugged unit is safe. Some components, particularly capacitors, can hold lethal charges for long periods of time.*
- *When power has to be applied, proceed with extreme caution. Whenever possible, use the "One Hand Rule" (keep one hand in your pocket).*
- *Use insulated tools, and hold them ONLY by the insulation.*

- *Wear insulated shoes.*
- *Work on a nonconductive surface, NEVER on a metal table.*
- *Be sure the work area is sufficiently lighted.*
- *The work area in general should be clean and well organized.*
- *Remember that heat may also be a danger. Some components get very hot during operation.*
- *Some tools, such as soldering irons, are meant to be hot. If the tip is hot enough to melt solder, it is hot enough to cause serious burns, damage to components and surfaces, and if you're careless the tip can melt through wires, including the tool's power cord.*
- *Always use the right tool for the job. For example, the tip of the screwdriver or wrench has to fit correctly. When clipping wires, use a wire cutter (and of the right size) not scissors.*
- *When replacing components, use an exact replacement.*
- *Remember: WHEN IN DOUBT, DON'T DO IT!*

### **Electrical Shock**

Usually there is very little danger from the DC voltage in most equipment. It is generally of low value, in voltage and current. The greatest danger in these areas is to the equipment itself.

However, do not throw caution to the wind. Always assume the voltage and current are lethal, and you won't get into trouble.

Unless the device is powered by batteries, there is a power supply. This converts AC into DC. The danger to you begins at the wall outlet and could continue well past the power supply. (A television set, for example, takes a very high voltage from the power supply to drive the picture tube.)

The AC in the standard wall outlet is 117 VAC (nominal) and is normally protected by a 15 A or 20 A breaker or fuse. The purpose of the breaker or fuse is to reduce the danger of fire. DO NOT count on them to protect you or the equipment.

At 117 VAC, it takes just a fraction of an amp to cause your muscles to become

**2/3**  
**Safety**  
**Procedures**

paralyzed. If this happens you won't be able to let go of what is causing the shock. With just a fraction of an amp more, your heart can become paralyzed.

That fuse or breaker allows 15 or more amps to flow almost indefinitely. This is hundreds of times what it takes to kill a person. Worse, since these breakers are designed to allow the heavier current draw for times when motors start, for a second or so the amperage flowing can be much higher.

The lesson, again, is that you should not be thinking of that breaker or fuse as a device that will protect you. It won't!

As stated above, when working around dangerous voltages and currents, you need to be insulated from the surroundings. It is not overly cautious to work on an insulated surface, while wearing insulated shoes on an insulated floor. Even then, keep one hand in your pocket (the "One Hand Rule") to avoid accidentally having yourself become part of the AC circuit. Merely keeping that other hand back isn't enough. You might be tempted to reach forward with it. Placing it in your pocket will force you to think about what you are doing.

**Fire**

Hopefully you will never have to deal with this problem. If you are careful, you never will. However, you need to be prepared, just in case.

The first step is to be sure that there is a safe and quick exit from the work area. This is yet another reason to keep the working area clean and uncluttered. If you have to get out of the area fast, climbing over boxes or taking the chance of tripping on electrical cords increases the danger.

Why would you suddenly have to flee? There are two main reasons. One is that you may not be able to get the fire under control. The other is that some electrical fires can release poisonous gases in the air.

Even if the fire is out, it may not be safe for you to remain.

At least one fire extinguisher should be immediately at hand, and easily accessible. This must be of the right type. For electrical fires you'll need the dry powder type (Type C). Liquids, and water in particular, only make matters worse.

Having a fire extinguisher around won't do much good if you don't know how to use it. The unit should also be serviced on a regular basis (some suggest once per year as a minimum). Don't rely on the gauge. Even if it shows "good" on the dial, the unit may not be functioning.

The working area should be protected with a proper alarm system. The fire alarm, like the fire extinguisher, should be tested regularly. Experts suggest that once per month is not too frequent.

## First Aid

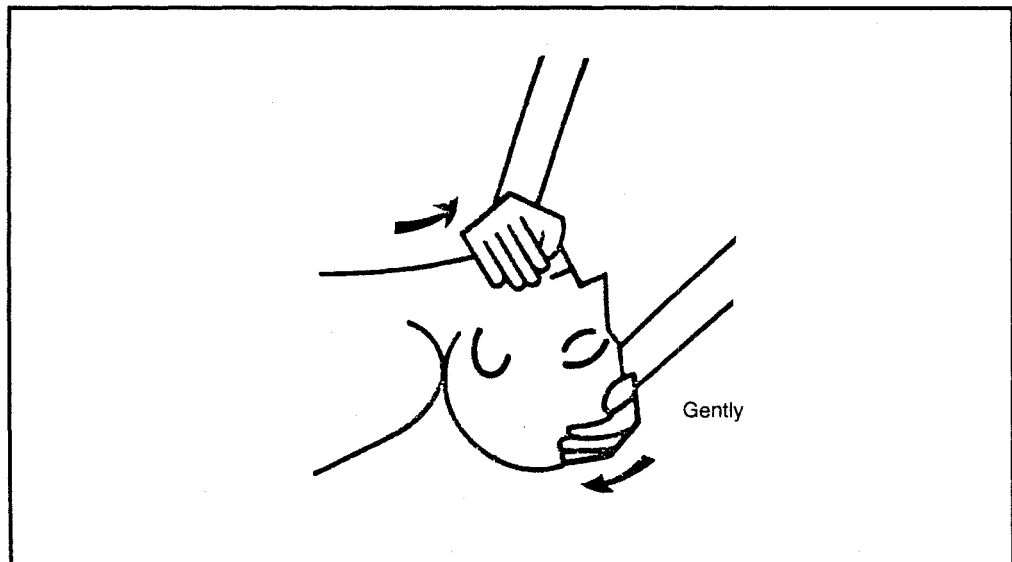
It is a good idea to have a quality first aid manual. You should know the basics—and know them well enough to apply them calmly under an emergency situation. You might even consider taking classes. Many hospitals and medical clinics offer free classes in CPR.

The working area should contain a complete first aid kit. As supplies are used from it, they should be replaced. Make sure that the kit is always fully stocked, and with fresh materials.

### The Shock Victim

In the event of an electrical shock the first thing to do is to disconnect the power supply, or remove the person from the supply. Do this **ONLY** if it can be done safely and without risk of shock to yourself. This may mean standing on insulating material (if available) and pushing the live conductor with an insulator, such as a broom handle.

If the person is not breathing, and the heart is not beating, it is essential to act as quickly as possible. The ABC of first aid in these circumstances is:



**Figure 1:** Turn the person onto their back and tilt the head.

**2/3**  
Safety  
Procedures

---

---

---

---

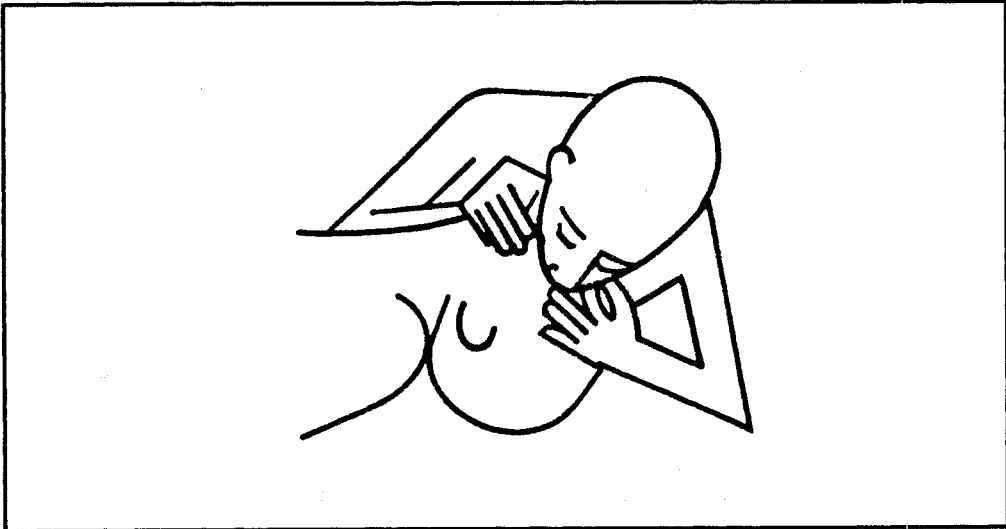
**Airway**

Open the airway by rolling the person on his or her back, gently lifting the chin forward with one hand while pressing the forehead back with the other. This has the effect of lifting the tongue forward so that it does not block the airway. (See Figure 1).

**Breathing**

Pinch the victim's nose with your fingers and close it. Take a deep breath, and blow into the victim's mouth. Watch the chest to see if it rises (Figure 2). Remove your mouth and see if the chest sinks. If the chest does not go up and down, adjust the position of the head and jaw to clear the airway (Figure 3). Repeat the process.

Now check for a pulse as an indicator that the heart is beating (Figure 4). If it is not, go immediately to "Circulation".



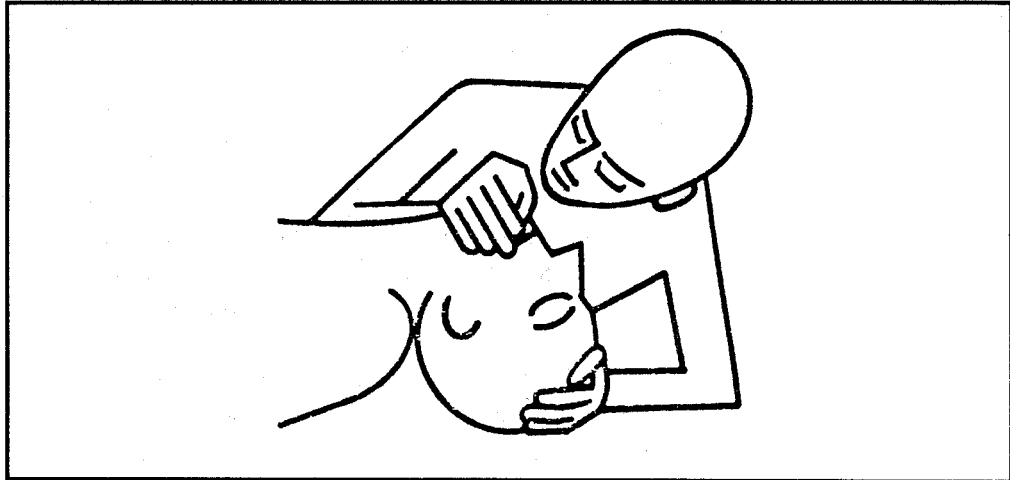
**Figure 2:** Pinch the nose, create a seal between your mouth and theirs, and blow while watching to see if their chest rises.

If the heart is beating, continue mouth-to-mouth resuscitation at a rate of about 14 times per minute until natural breathing begins again.

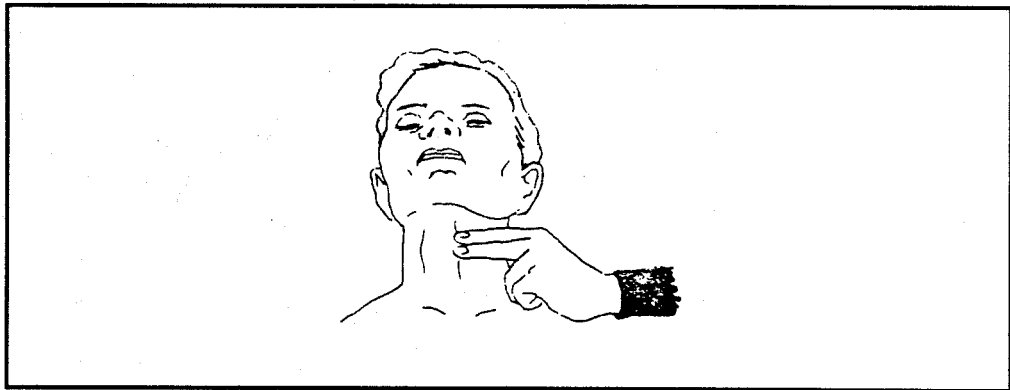
When natural breathing has started, put the victim in the recovery position. That is, move the person so that the front of the body is to the ground and the head is resting with the right side to the ground and the chin tilted to keep the airway clear (Figure 5). The right arm should be down and beside the body, with the left arm forward. The left knee should be bent.

**Circulation**

The most reliable way for an amateur to check the pulse of an unconscious person is as follows:



**Figure 3:** If the chest does not rise and fall, tilt the chin again.



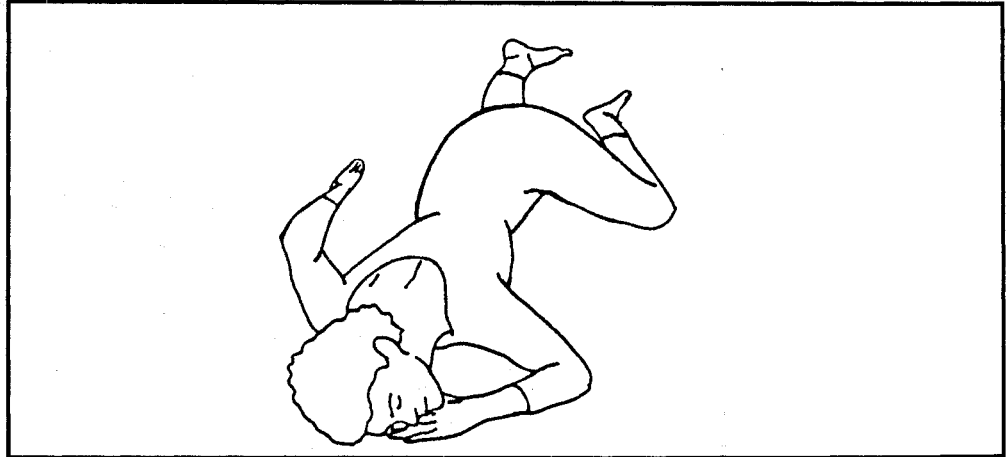
**Figure 4:** Check the pulse for sign of heartbeat.

Place two fingertips on the voice box (Adam's apple) and slide them around the neck to either side. A pulse should be felt in either of the two carotid arteries that run up the sides of the neck (Figure 4).

The victim must be on his or her back and on a firm surface. Kneel beside the victim and find the point where the ribs join at the bottom of the breastbone. Place the heel of one hand on the breastbone about two finger-widths above this point. (Figure 6.) Put your other hand on top of the first and get into position over the victim with your arms straight and your shoulders directly above the breastbone.

Keeping your arms straight, press down on the breastbone about 2 inches. Relax the pressure and repeat the process at a rate of just over one per second. Don't



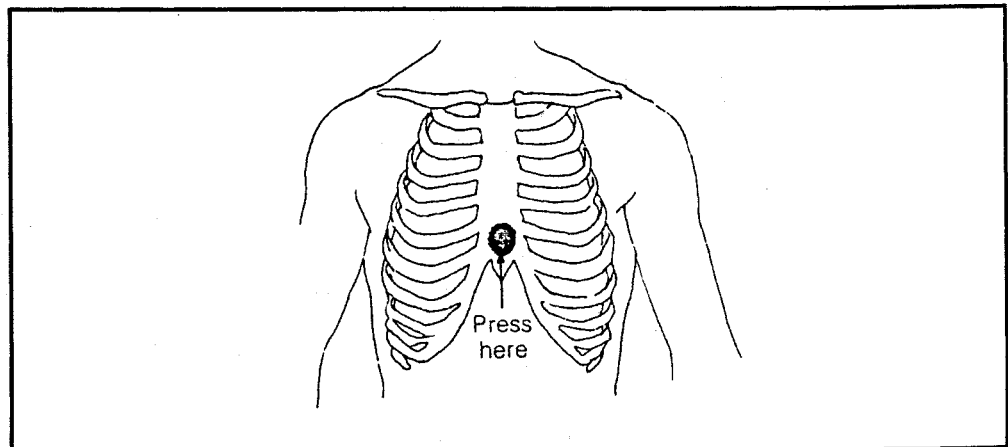


**Figure 5:** With breathing restored, move the person into the recovery position.

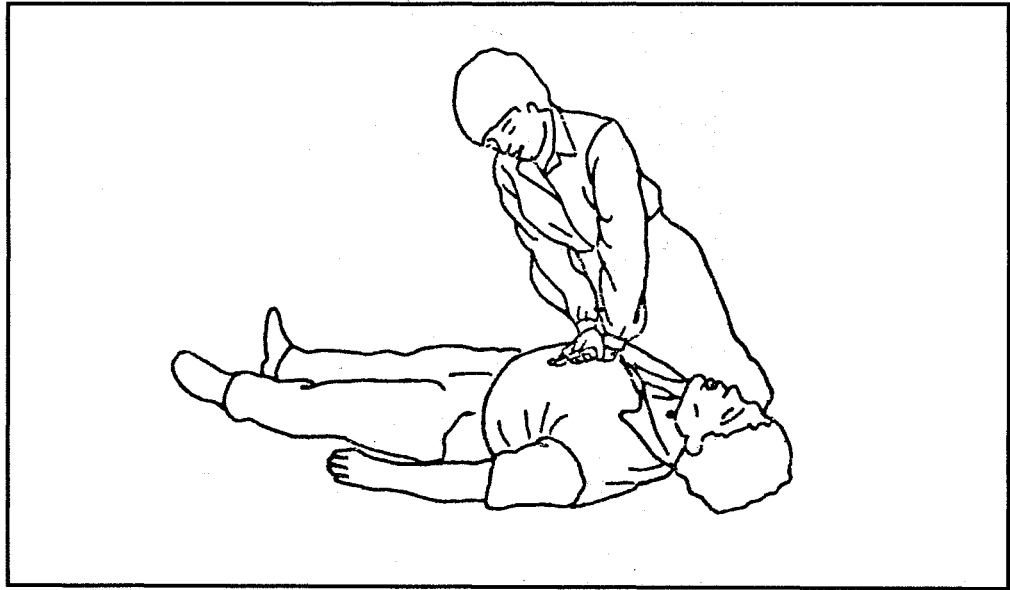
bang on the chest. Try to simulate the smooth, steady action of normal beating. Complete 15 of these actions and then go back to the head, open the airway and give two cycles of mouth-to-mouth resuscitation.

Continue with 15 chest compressions followed by two mouth-to-mouth cycles, checking for a pulse after the first minute and then repeating the entire cycle again, with a pulse check every three minutes.

Stop the chest compressions as soon as a pulse is detected. Continue mouth-to-mouth until natural breathing starts. If necessary, assist with the natural breathing to help the victim return to his or her natural rate.



**Figure 6:** Pushing on the spot shown causes pressure on the heart.



**Figure 7:** The CPR position.

# Section 3

## Electronics Repair Basics

### Table of Contents

#### 3/2 *Electronics Fundamentals*

3/2 - C	<i>Components</i>
3/2 - C - AC	<i>Active Components</i>
3/2 - C - AC - A	<i>An Introduction</i>
3/2 - C - AC - D	<i>Diodes</i>
3/2 - C - AC - IC	<i>Integrated Circuits</i>
3/2 - C - AC - L	<i>Logic ICs</i>
3/2 - C - AC - LED	<i>Light Emitting Diodes</i>
3/2 - C - AC - OpAmp	<i>Operational Amplifiers</i>
3/2 - C - AC - T	<i>Transistors</i>
3/2 - C - AC - Ti	<i>Timers</i>
3/2 - C - AV - Thy	<i>Thyristors</i>
3/2 - C - AC - Tr	<i>Triacs</i>
3/2 - C - AC - VR	<i>Voltage Regulators</i>
3/2 - C - PC	<i>Passive Components</i>
3/2 - C - PC - A	<i>An Introduction</i>
3/2 - C - PC - C	<i>Capacitors</i>
3/2 - C - PC - I	<i>Inductors</i>
3/2 - C - PC - R	<i>Resistors</i>
3/2 - C - PC - T	<i>Transformers</i>
3/2 - O	<i>Ohm's Law</i>
3/2 - PVC	<i>Power, Voltage, Current</i>
3/2 - QUS	<i>Quantities, Units, Signals</i>

#### 3/3 *Troubleshooting Techniques*

#### 3/4 *Soldering/Desoldering*

3/4 - D	<i>Desoldering</i>
3/4 - S	<i>Soldering</i>

Table of  
Contents

---

---

---

---

3/2 - C	Components
3/2 - C - AC	Active Components
3/2 - C - AC - A	An Introduction

## **3/2 - C - AC**

### **Active Components**

---

## **3/2 - C - AC - A**

### **An Introduction**

---

Passive components “condition” the current but cannot generate or amplify it. Even with a transformer, where there is an apparent increase in power, the increase in the voltage level is accompanied by a decrease in the amperage. In an ideal (theoretical) transformer, the two balance and there is no net gain in power. (In reality there is a net loss.)

Active components can do a variety of things to the current. They can amplify it, modify it in a number of ways and basically make it behave in a desired manner.

Vacuum tubes are active components. However, they have been almost entirely replaced by semi-conductors (diodes, transistors, etc.). Semi-conductors are smaller, lighter, or require less energy to operate and are tougher and more capable. You may encounter tubes in old equipment or in equipment that handles large amounts of power (such as large transmitters). Even here tubes are disappearing, since semi-conductors can handle more power.

Section 3 • Electronic Repair Basics

**3/2**  
Electronic  
Fundamentals

3/2 - C	Components
3/2 - C - AC	Active Components
3/2 - C - AC - A	An Introduction

3/2 - C	Components
3/2 - C - AC	Active Components
3/2 - C - AC - D	Diodes

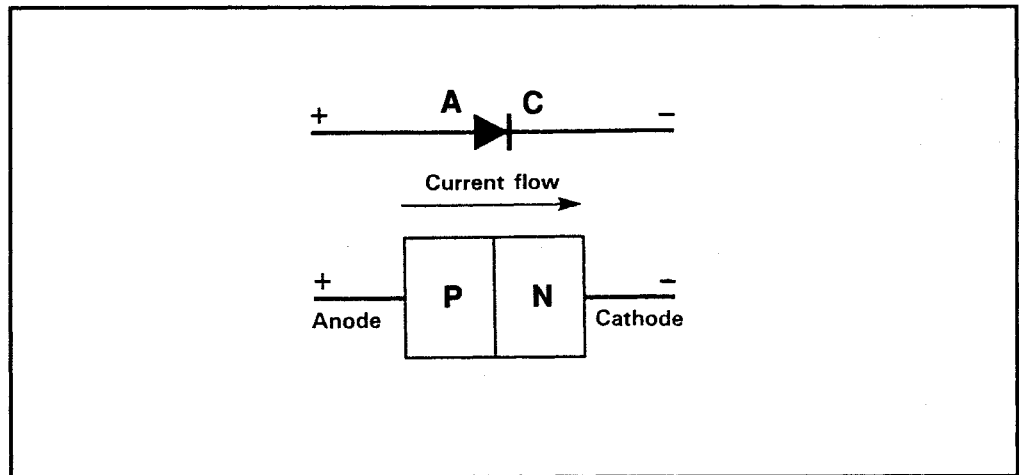
## 3/2 - C - AC

### Active Components

## 3/2 - C - AC - D

### Diodes

Diodes generally comprise a semiconductor P-N junction of either silicon (Si) or germanium (Ge). In order to obtain conduction, the P-type material must be made positive with respect to the N-type material. (The N-type connection is the cathode.) The direction of current flow is from anode to cathode when the diode is conducting (as shown in Figure 1). Very little current flows in the reverse direction. (The amount of reverse current is negligible in most silicon devices.)



**Figure 1:** Forward biased (conducting) diode

Diodes exhibit a low resistance to current flow in one direction and a high resistance in the other. The direction in which current flows is referred to as the forward direction, while negative current is called the reverse direction. When a diode is conducting, it is said to be forward biased, and a small voltage (ideally zero) is dropped across it. This voltage is known as the forward voltage drop. The maximum reverse voltage that a diode can tolerate is usually specified in terms of its reverse repetitive maximum voltage, or peak inverse voltage (PIV).

**3/2**  
Electronic  
Fundamentals

3/2 - C	Components
3/2 - C - AC	Active Components
3/2 - C - AC - D	Diodes

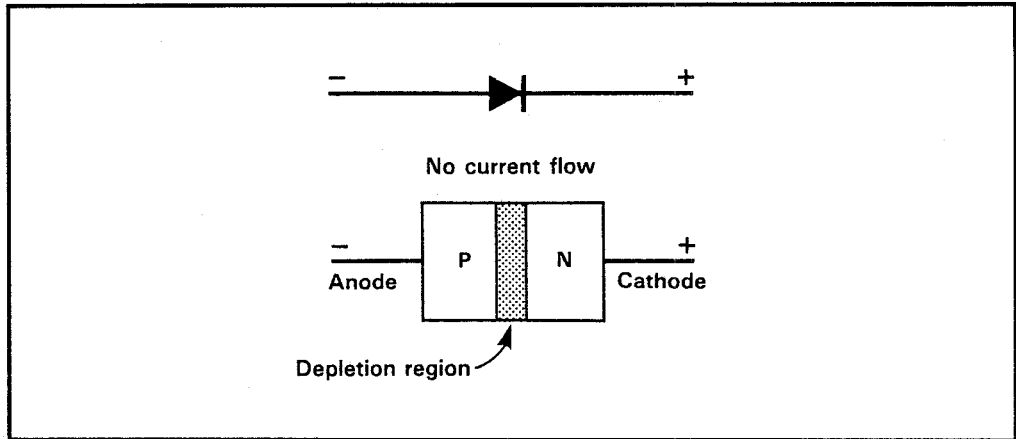


Figure 2: Reverse biased (non-conducting) diode

Typical values of forward current and forward voltage for commonly available silicon and germanium diodes are given below:

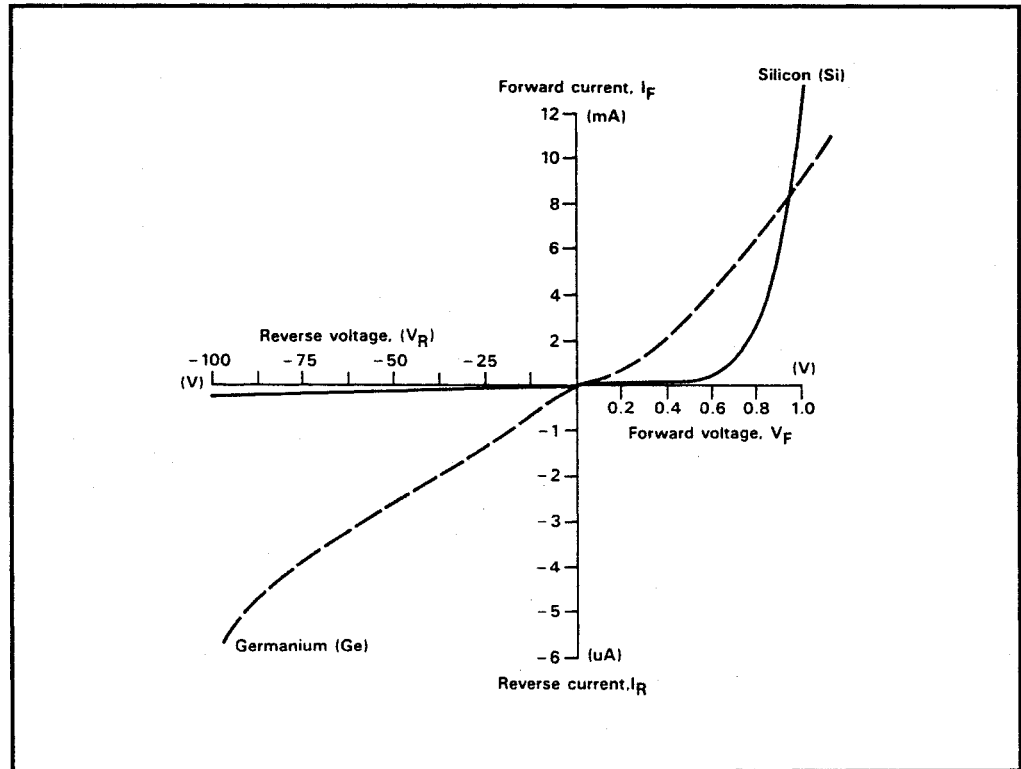
Table 1  
Value of Forward  
Current and  
Forward Voltage  
Drop

	Forward Current		Forward Voltage Drop	
	Silicon (1N4148)	Silicon (1N5401)	Silicon (1N5401)	Germanium (0A91)
10µA	0.43V	-	0.55V	0.12V
100µA	0.58V	-	0.60V	0.26V
1mA	0.65V	-	0.65V	0.32V
10mA	0.75V	-	0.72V	0.43V
100mA	-	-	0.85V	-
1A	-	-	-	-

Germanium diodes conduct at lower forward voltages than their silicon counterparts (typically 100 mV as compared with 600 mV) but they tend to exhibit considerably more reverse leakage current (1 µA as compared with 10 nA for an applied voltage of 50 V). The forward resistance of a conducting silicon diode is also generally much lower than that of a comparable germanium type. Thus germanium diodes are used primarily for signal detection purposes whereas silicon devices are used for rectification and for general purpose applications. Typical forward and reverse characteristics for comparable germanium and silicon diodes are shown in Figure 3.

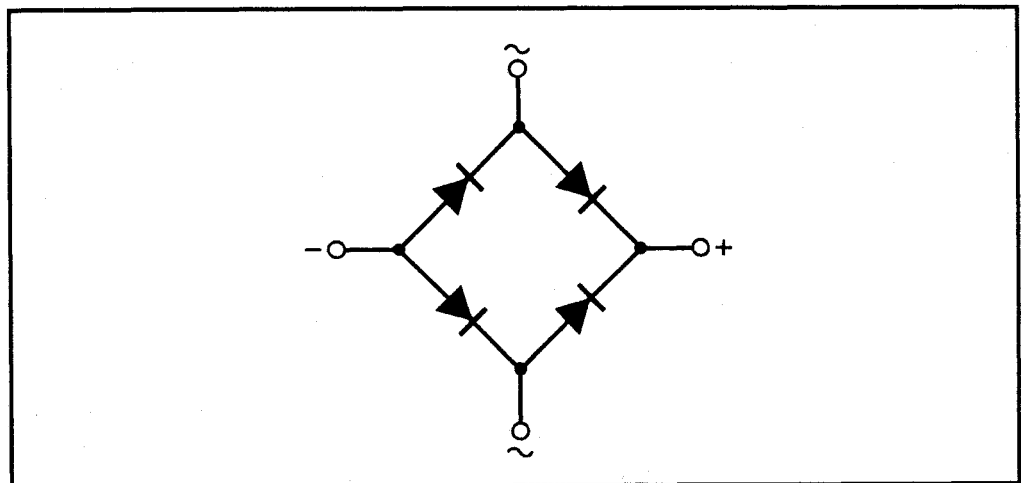
Diodes are often divided into signal and rectifier types according to their principal field of application. Signal diodes require consistent forward characteristics with low forward voltage drop. Rectifier diodes need to be able to cope with high values of reverse voltage and large values of forward current.





**Figure 3:** Typical characteristics for comparable silicon and germanium diodes

Consistency of characteristics is of secondary importance in such applications. Rectifier diodes are often available in the form of a bridge (see Figure 4) which proves full-wave rectification.



**Figure 4:** Bridge rectifier

**3/2**  
Electronic  
Fundamentals

3/2 - C	Components
3/2 - C - AC	Active Components
3/2 - C - AC - D	Diodes

**Commonly Used Abbreviations**

A = anode	$T_U$ = ambient temperature
C = cathode	$T_K$ = temp. coefficient of the zener voltage
$I_F$ = forward current	t = time
$I_R$ = reverse current	V = voltage
K = cathode (in some sources)	$V_{BR}$ = breakdown voltage
$P_{tot}$ = total power loss	$V_F$ = forward voltage
$R_{th}$ = thermal resistance	$V_R$ = reverse voltage
T = temperature	$V_Z$ = zener voltage
$T_G$ = casing temperature	PIV = peak inverse voltage
$T_J$ = junction layer temperature	$V_{RRM}$ = max. repetitive reverse voltage

**Diode Coding**

Diode coding can be confusing. At times, several conventions are used simultaneously. For example, a diode coded AA119 is actually a European labeling scheme (with the first letter signifying germanium, the second showing it to be a general purpose diode). Despite the fact that the label is European, the same diode, with the same label, can be found in the United States.

In the European labeling:

First Letter	Material	Second Letter	Purpose
A	germanium	A	general purpose
B	silicon	B	tuning (varicap)
C	gallium arsenide, etc.	E	tunnel
D	photo diodes, etc.	P	photovoltaic
		Q	light emitting (LED)
		T	controlled rectifier
		X	varactor
		Y	power rectifier
		Z	zener

With zener diodes, an additional letter may follow the number. This is the tolerance rating.

A	1%
B	2%
C	5%
D	10%

Some of these conventions can be found in the United States. Cross references for diodes that fulfill the same specifications are easily located (and are sometimes printed on the package).

3/2 - C	Components
3/2 - C - AC	Active Components
3/2 - C - AC - D	Diodes

Also common in the United States is the 1N and 2N prefix, which is generally taken to mean that the device is from National Semiconductor, with 1N being a diode and 2N being a transistor.

To make matters more confusing, the casing type may (and often does) have more than one designation. DO- is a military designation. A DO-7 case is glass, 7.6 mm long 2.5 mm in diameter. This same casing can be DO-204AA, which is military low-cost. And the same is available as Case 51-02, which generally refers to a consumer product.

Do not worry about this too much. Virtually every parts supplier can cross reference. Complete cross reference guides are also available should you wish to purchase one. These contain data about all the different semiconductors, often up to and including ICs and CPUs. (If those are contained, pin-outs and other

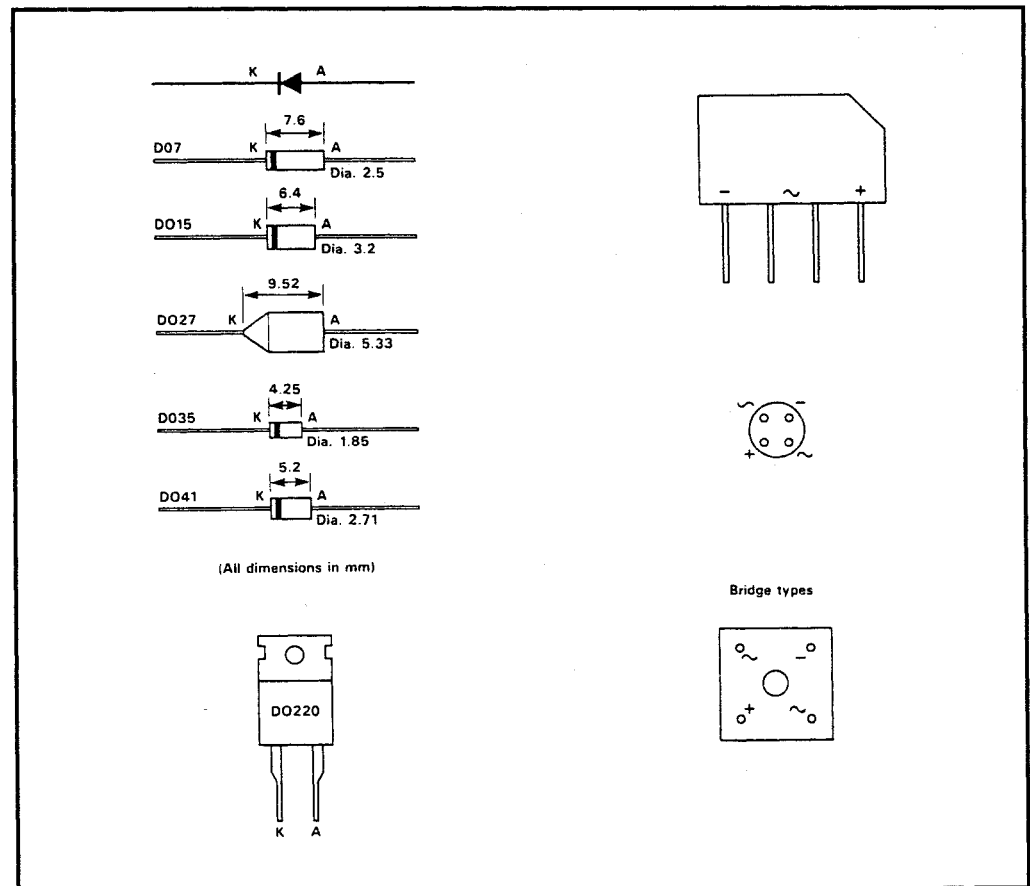


Figure 5: Diode casings

3/2 - C	Components
3/2 - C - AC	Active Components
3/2 - C - AC - D	Diodes

technical data for the devices are often given.)

Motorola, one of the world's largest producers of semiconductor devices, has more than 50 parts sales offices across the country, and a central office which distributes literature. This includes "The Motorola Semiconductor Master Selection Guide," which is considered by many to be the definitive reference source on semiconductor cross-referencing and data.

Those with computers can get all this information on disk, making access even easier.

The software is available through a Motorola sales office, through the Motorola Literature Distribution center, and even via download from various computer BBS around the country.

If you can't find it in your area, contact:

**Motorola Literature Distribution Center**  
 PO Box 20912  
 Phoenix, AZ 85036

The following are some typical diode listings and specifications (R = Reverse; F = Forward):

**Example  
 Germanium Diodes**

Type	R Voltage	F Voltage	F Current (mA)
AA113	60	1.1	10
AA116	20	1.0	30
AA117	90	1.2	50
AA118	90	1.05	50
AA119	30	1.5	35
AA143	25	0.33	60
AA144	90	1.0	10
GD731	40	<1.0	50
GD741	40	<1.0	50
1N55A	150	<1.0	50
1N55B	180	<1.0	30
1N60	50	<1.0	30
1N87	22.5	<0.25	50
1N98A	80	<1.0	70
1N100A	80	<1.0	70
1N270	80	<1.0	-
1N276	50	<1.0	40
1N277	120	<1.0	-

(cont'd next page)

**3/2**  
Electronic  
Fundamentals

3/2 - C	Components
3/2 - C - AC	Active Components
3/2 - C - AC - D	Diodes

**Example**  
**Germanium Diodes**  
(cont'd)

Type	R Voltage	F Voltage	F Current (mA)
1N278	60	<1.0	-
1N283	25	<1.0	-
1N695	20	<1.0	100
1N695A	25	<0.5	150
1N994	8	<1.0	20
1N995	15	<0.5	30
1N996	25	<0.8	50
1N3466	40	<1.0	75
1N3467	15	<0.5	-
1N3469	35	<1.0	85

**Example**  
**Silicon Diodes**

Type	R Volts	F Volts	F Current (mA)	R Current (nA)	Power (mW)
BA170	20	1.0	150	50	300
BA201	50	1.2	150	100	500
BAV17	25	1.0	200	100	400
BAV18	60	1.0	200	100	400
BAV19	120	1.0	200	100	400
BAV20	200	1.0	200	100	400
BAV21	250	1.0	200	100	400
BAW75	35	1.0	150	100	500
BAW76	75	1.0	150	100	500
BAX13	50	1.53	48	200	500
BAX16	165	1.3	200	100	400
1N456A	30	1.0	150	<25	400
1N457	60	1.0	150	<25	400
1N458A	150	1.0	150	<25	400
1N459A	200	1.0	150	<25	400
1N483A	70	1.0	150	<25	400
1N483B	80	1.0	150	<25	400
1N484A	150	1.0	150	<25	400
1N484B	150	1.0	150	<250	400
1N485	200	1.0	150	<250	400
1N485A	200	1.0	150	<25	400
1N485B	200	1.0	150	<25	400
1N486	250	1.1	150	<250	400
1N486B	250	1.1	150	<25	400
1N914	100	1.0	75	<25	500
1N916	100	-	75	<25	500
1N4148	100	1.0	150	<25	500
1N4149	100	1.0	150	<25	500
1N4150	50	1.0	200	<100	500
1N4151	75	1.0	150	<50	500
1N4152	40	0.55	150	<50	400
1N4153	75	0.55	150	<50	400
1N4154	35	1.0	150	<100	500
1N4305	75	0.58	150	<100	400

(cont'd next page)

3/2 - C	Components
3/2 - C - AC	Active Components
3/2 - C - AC - D	Diodes

### Example Silicon Diodes (cont'd)

Type	R Volts	F Volts	F Current (mA)	R Current (nA)	Power (mW)
1N4446	100	1.0	150	<25	500
1N4447	100	1.0	150	<25	500
1N4448	100	1.0	150	<25	500
1N4449	100	1.0	150	<25	500
1N4450	40	0.54	150	<50	400
1N4451	40	0.50	150	<50	400
1N4453	30	0.55	150	<50	400
1N4454	75	1.0	150	<100	400

### Zener Diodes

Zener diodes are special types of silicon diodes that exhibit consistent reverse voltage breakdown characteristics. Zener diodes are available in various families (according to their general characteristics, casings and power ratings) with the reverse breakdown (zener) voltages in the 2.4 V to 91 V range.

A typical characteristic for a 5.6 V zener diode is shown in Figure 7. Note that the forward characteristic has exactly the same shape as that of a conventional silicon diode (conducting rapidly at 600 mV). The reverse characteristic has a much greater slope such that the current rises very rapidly beyond the zener voltage.

Zener diode casings are generally plastic or glass and appear identical to conventional silicon diodes. As is the case with conventional silicon diodes, the cathode connection is marked with a stripe (see Figure 6).

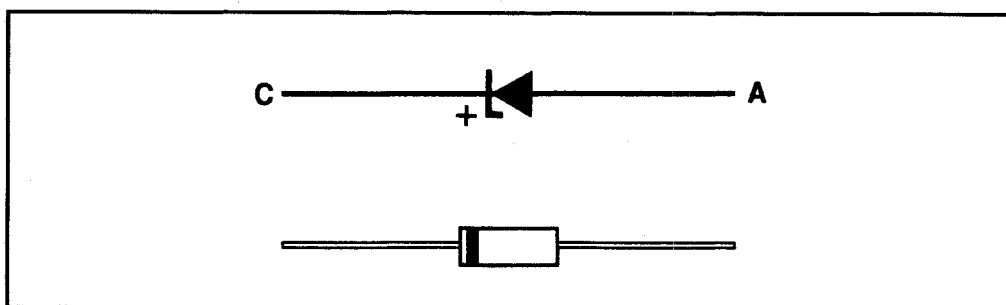


Figure 6: Zener diode symbol and typical casing

**3/2**  
Electronic  
Fundamentals

3/2 - C

Components

3/2 - C - AC

Active Components

3/2 - C - AC - D

Diodes

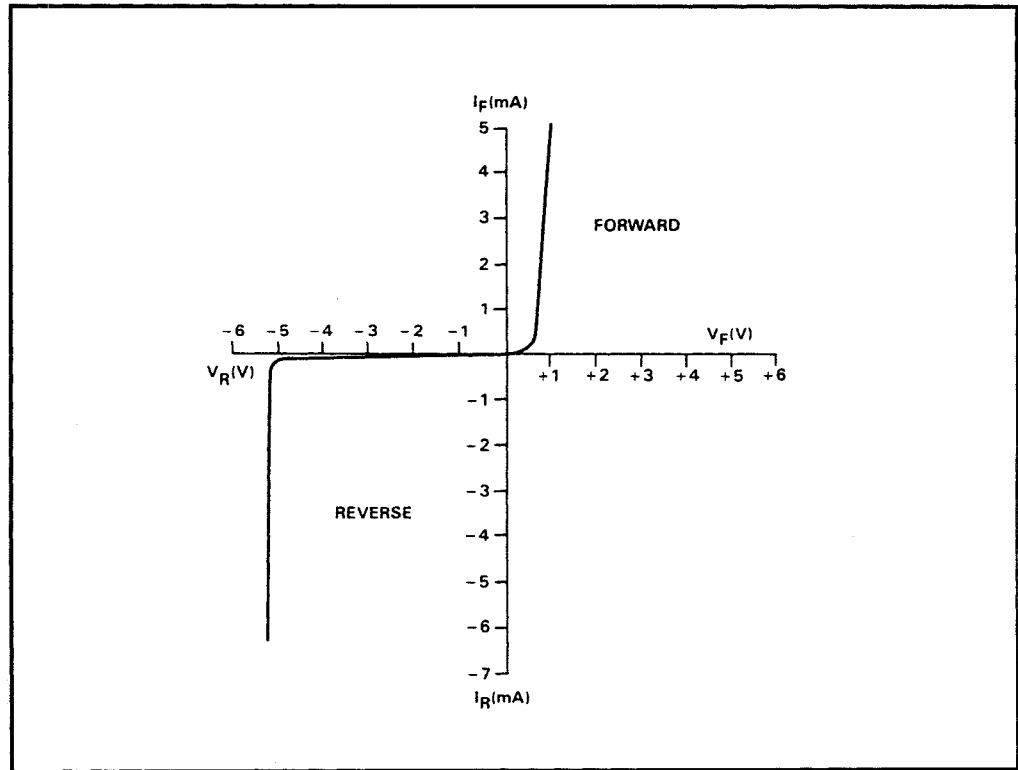


Figure 7: Zener diode characteristics

Section 3 • Electronic Repair Basics

**3/2**  
Electronic  
Fundamentals

3/2 - C	Components
3/2 - C - AC	Active Components
3/2 - C - AC - D	Diodes



# 3/2

Electronic  
Fundamentals

3/2 - C	Components
3/2 - C - AC	Active Components
3/2 - C - AC - IC	Integrated Circuits

## 3/2 - C - AC

### Active Components

---

## 3/2 - C - AC - IC

### Integrated Circuits

---

#### General Introduction

Transistors were a remarkable invention. Devices could be made much smaller and lighter, and less power was needed to run them. The radio that once filled a large cabinet in the corner of a room, and that required 120 VAC, could be put into a box small enough to fit in a pocket and powered by small batteries. Then came the technology that made it possible to build hundreds or even thousands of transistors, and the related components, into a small, thin plastic case.

This is the integrated circuit (IC), often called a “chip” because of its appearance. In electronics the IC is a mixed blessing. It allows devices to be even smaller, while having more features, and to operate on just a trickle of electrical energy. It also means that repair at the component level is quickly disappearing.

Many ICs are standard and have common pinouts. With the proper manual (such as WEKA’s *“The Modern IC Databook”*) you can look up the particular chip to find out which pins carry which signals. This may help you to locate which IC has gone bad—or the failure could be caused by a cascading effect with one chip or component elsewhere causing others to malfunction.

Another problem is that some ICs are proprietary. This means that even if you locate which IC is causing the trouble, you may not be able to get a replacement. The combination of the two often puts the technician in a position in which the “fix” is to replace an entire circuit board - and sometimes the entire device.

How the IC is structured inside, and how it is manufactured, depends on its design and purpose.

Integrated circuits are complex circuits fabricated on a tiny slice of silicon. They may contain the equivalent of as few as 10 or as many as 100,000 active devices (diodes and transistors) and may be divided into two general classes—linear (analog) or digital.

3/2 - C	Components
3/2 - C - AC	Active Components
3/2 - C - AC - IC	Integrated Circuits

Linear ICs are designed for applications which involve voltage amplification, signal generation and analog signal processing. Typical examples of linear integrated circuits include the vast majority of consumer ICs used in radio, television and hi-fi equipment, and they are also common as operational amplifiers (used in all areas of electronics).

Digital integrated circuits are designed for use in conjunction with digital signals (i.e., the signals consisting of two distinct voltage states, usually known as either high and low, or as logic 1 and logic 0). Typical examples of digital ICs are logic gates, digital counters and shift-registers.

Some integrated circuits combine both digital and analog technology. Examples are analog-to-digital converters (ADC) and digital-to-analog converters (DAC), and certain varieties of timer devices. The immensely popular 555 timer, for example, contains two operational amplifier comparators (both considered to be linear devices) together with a bistable stage (a digital device).

ICs are commonly used in almost every branch of electronics. Not only are they the most cost-effective method of realizing many practical circuit configurations, they also offer much greater reliability when compared with the equivalent circuitry based on discrete components.

**Scale of Integration** A relative measure of the number of individual semiconductor devices within an integrated circuit is popularly used to describe the scale of integration achieved within digital devices. The following terminology is often used:

Scale of integration	Abbr.	Number of logic gates*
Small	SSI	1 to 10
Medium	MSI	10 to 100
Large	LSI	100 to 1000
Very Large	VLSI	1000 to 10,000
Super Large	SLSI	10,000 to 100,000

\*or equivalent circuits

Despite their obvious advantages in minimizing the component count within a piece of equipment and reducing the overall area of the PC board required, ICs do have some shortcomings when high currents or high voltages are involved. Devices required to work at an appreciable power level (1 W or more) require heat-sinking. Furthermore, at power levels in excess of 20 W, discrete devices are generally preferred. In high-power audio applications it is, therefore, not unusual to find hybrid circuitry which involves integrated circuit operational amplifiers (operating as voltage amplifiers at low-power levels) working in

# 3/2

Electronic  
Fundamentals

3/2 - C	Components
3/2 - C - AC	Active Components
3/2 - C - AC - IC	Integrated Circuits

conjunction with conventional transistors or MOSFETs (to provide the necessary power gain at the output).

## Encapsulation

The most popular form of encapsulation used for ICs is the dual-inline package (DIP). The package itself may be fabricated from either plastic or ceramic material (with the latter using a glass hermetic sealant). Common DIPs have 6, 8, 14, 16, 18, 20, 24 or 40 pins.

Flat package (flatpack) construction (using both glass-metal and glass-ceramic seals and welded construction) are popular for planar mounting on flat circuit boards. No holes are required to accommodate the leads of such devices which are arranged on a 0.05 inch pitch (i.e., half the pitch used with standard DIP devices). This form of casing requires special handling, and repair should not be attempted unless the correct re-working equipment is available.

Single-inline packages (SIPs) and quad-inline packages (QIPs) are also becoming increasingly popular, while TO-5, TO-72, TO-3 and TO-220 casings are also found (the latter being commonly used with voltage regulators).

## IC Coding

Once again we find a coding system which demonstrates how our world is becoming smaller. Conventions are almost interchangeable. This is made more complicated by users often reducing the coding of a chip to a few digits (e.g., 386) and more complicated yet because each manufacturer may have its own code for the same IC.

Efforts are being made to reduce this confusion, but it will take a long time. Meanwhile, the technician is once again forced to look through cross-reference manuals (which are fortunately easy to find and constantly updated).

Section 3 • Electronic Repair Basics

**3/2**

**Electronic  
Fundamentals**

<b>3/2 - C</b>	<b>Components</b>
<b>3/2 - C - AC</b>	<b>Active Components</b>
<b>3/2 - C - AC - IC</b>	<b>Integrated Circuits</b>

3/2 - C	Components
3/2 - C - AC	Active Components
3/2 - C - AC - L	Logic ICs

## 3/2 - C - AC

### Active Components

## 3/2 - C - AC - L

### Logic ICs

### Logic Gates

#### Basic Function

Logic gates are digital ICs with a wide range of applications in electronics. Logic gates operate using binary signals. Such signals have two states, commonly referred to as logic 0 and logic 1. In conventional (positive) logic, the logic state is represented by a low voltage while the logic 1 is represented by a high voltage. In practice, the voltage levels used to represent the logical states depend on the semiconductor technology employed, as well as the supply voltages. In normal transistor-transistor logic (TTL) the logic 0 condition is represented by a voltage in the range of 0 V to +0.8 V, while the logic 1 condition is represented by a voltage in the range of +2.0 V to +5.0 V.

#### Logic Families

The logic family to which a device belongs is largely determined by its operational characteristics (such as power consumption, speed, and immunity to noise). The two basic logic families are TTL and CMOS, which are further divided into a number of sub-families based on different manufacturing technologies. TTL logic gates and related digital devices are found in the popular 74-series of ICs. Each device within the family is coded with the prefix 74 and variants within the family are identified by letters which follow the 74 prefix as follows:

Letters	Meaning
none	Standard TTL device
C	CMOS version
F	"Fast" - a high speed version
H	High speed version
L	Low power version
S	Schottky input configuration (improved speed and noise immunity)
AC	High speed, low power
HC	High speed CMOS version (CMOS inputs)
HCT	High speed CMOS version (TTL inputs)
LS	Low power version with Schottky inputs
ALS	Advanced low power version with Schottky inputs

3/2 - C	Components
3/2 - C - AC	Active Components
3/2 - C - AC - L	Logic ICs

Popular CMOS logic devices form the 4000-series. Variants within the family are identified by suffix letters as follows:

Suffix	Meaning
none	Standard CMOS device
A	Standard unbuffered
B, BE	Improved buffered
UB, UBE	Improved unbuffered

Examples of CMOS and TTL device coding are given below:

Code	Meaning
4001UBE	an improved, unbuffered version of the CMOS 4001
74LS14	low power version of the TTL 7414, fitted with Schottky inputs
4069B	a buffered version of the standard 4069
74HC259	a high speed CMOS version of the 74259 TTL device

### Logical Functions and Truth Tables

A logic gate generally has one or more inputs and a single output. Its logical function is described by the logical condition which relates its output to the input(s). Several functions are commonly encountered including AND, NAND, OR and NOR.

The logical function of a gate is specified in terms of a truth table that relates the logical state of its output to every possible combination of input. Since a digital signal can have two states (0 or 1) a gate with two inputs can have, for example, four different combinations of input (0 and 0, 0 and 1, 1 and 0, and 1 and 1). A gate with three inputs can have eight possible input combinations, and so on.

The American Standard (MIL/ANSI) symbols for some basic logic gates are shown with their truth tables in Figure 3 to 7. Inverters and buffers each have one input, exclusive-OR gates have two inputs and other basic gates (AND, OR, NAND and NOR) are available with up to eight inputs.

### Buffers

Buffers do not affect the logical state of a digital signal. That is, a logic 1 input results in a logic 1 output whereas a logic 0 input results in a logic 0 output. Buffers are normally used to provide extra current drive at the output but can also be used to regulate the logic levels present at an interface. The symbol and truth table for a buffer is shown in Figure 1.

### Inverters

Inverters are used to complement the logical state. That is, a logic 1 input results in a logic 0 output and vice versa. Inverters also provide extra current drive and, like buffers, are used in interfacing applications.

**3/2**  
Electronic  
Fundamentals

3/2 - C

Components

3/2 - C - AC

Active Components

3/2 - C - AC - L

Logic ICs

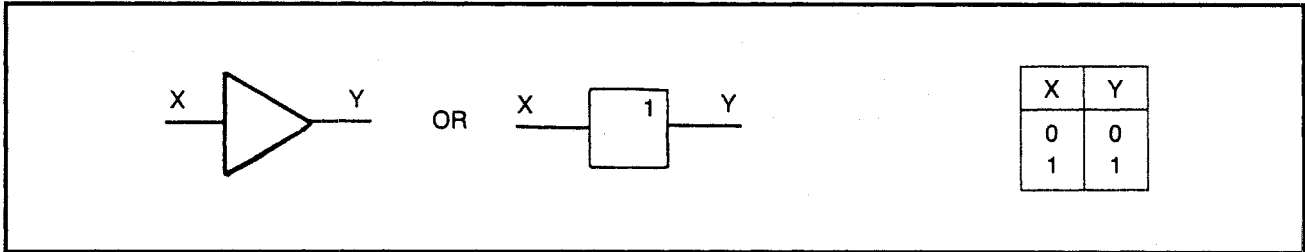


Figure 1: Symbol and truth table for a buffer

The symbol and truth table for an inverter is shown in Figure 2.

**AND Gates**

AND gates produce a logic 1 output when all inputs are simultaneously at logic 1. Any other input combination results in a logic 0 output. The symbol and truth table for an AND gate is shown in Figure 3.

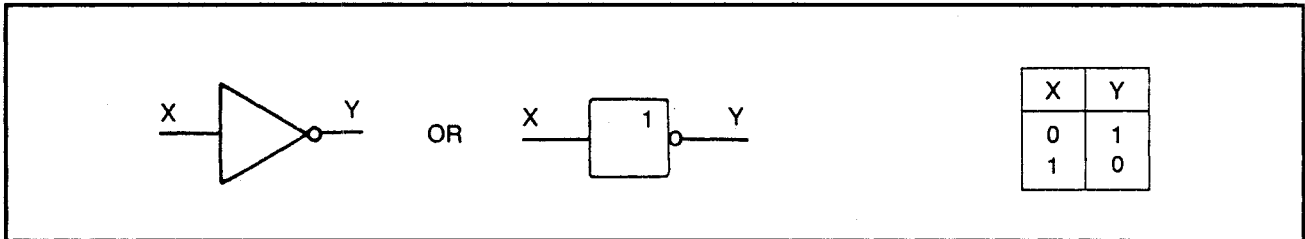


Figure 2: Symbol and truth table for an inverter

**OR Gates**

OR gates produce a logic 1 output whenever any one (or more) input is at logic 1. The OR gate produces a logic 0 output only when all of its inputs are simultaneously at logic 0. The symbol and truth table for an OR gate is shown in Figure 4.

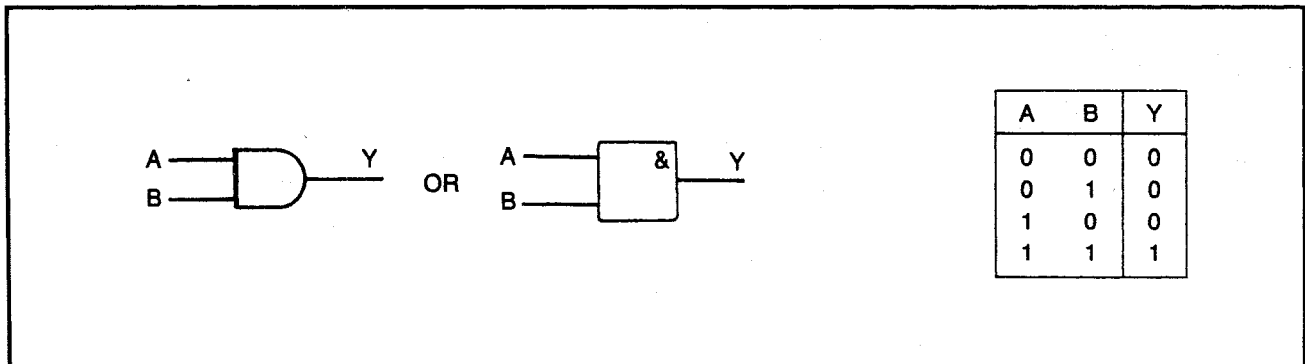


Figure 3: Symbol and truth table for an AND gate

**NAND Gates**

NAND gates produce a logic 0 output only when all inputs are simultaneously at logic 1. Any other combination produces a logic 1 output. A NAND gate, therefore, is an AND gate with its output inverted. The symbol and truth table for a NAND gate is shown in Figure 5.

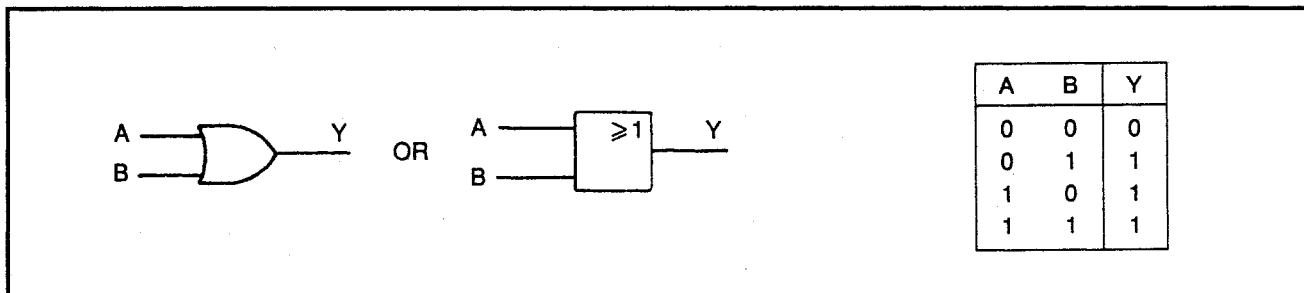


Figure 4: Symbol and truth table for an OR gate

**NOR Gates**

NOR gates produce a logic 1 output when all inputs are simultaneously at logic 0. Any other combination produces a logic 0 output. A NOR gate, therefore, is an OR gate with its output inverted. The symbol and truth table for a NOR gate is shown in Figure 6.

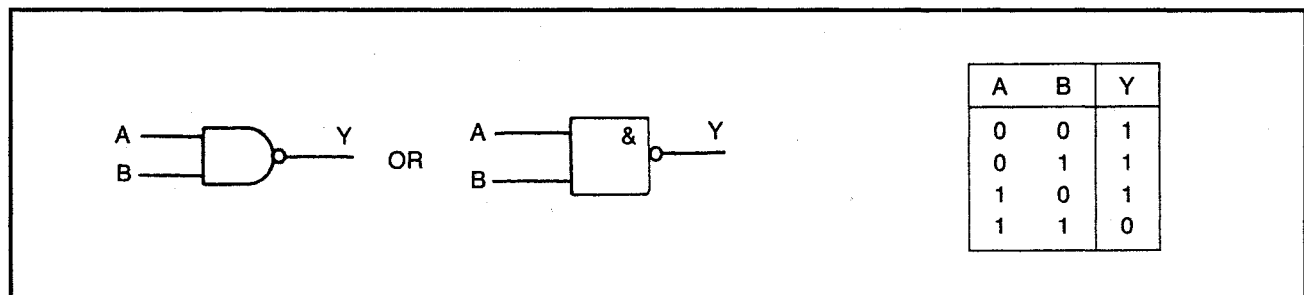


Figure 5: Symbol and truth table for a NAND gate

**Exclusive OR  
Gates**

Exclusive-OR gates produce a logic 1 output when one of the inputs is at logic 1 and the other is at logic 0. Exclusive-OR gates produce a logic 0 whenever both inputs have the same logical state. The symbol and truth table is shown in Figure 7.

**Monostables****Basic Function**

A logic device which has only one stable output state is known as a monostable. The output of such a device is initially at logic 0 (low) until an appropriate level



**3/2**  
Electronic  
Fundamentals

3/2 - C

Components

3/2 - C - AC

Active Components

3/2 - C - AC - L

Logic ICs

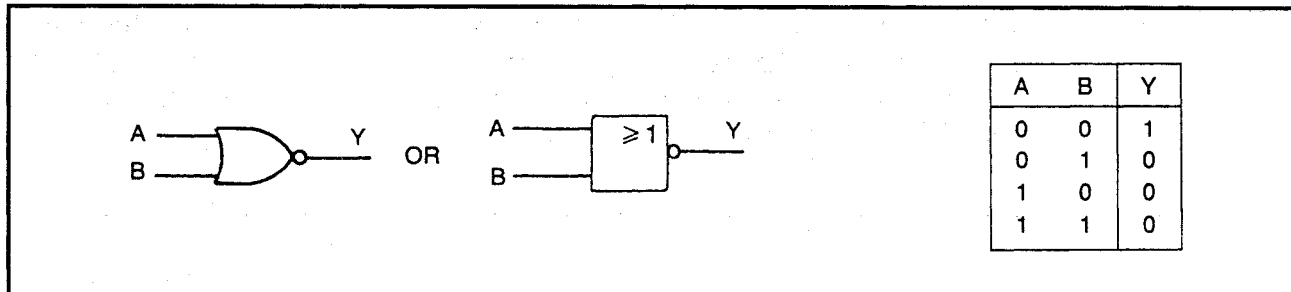


Figure 6: Symbol and truth table for a NOR gate

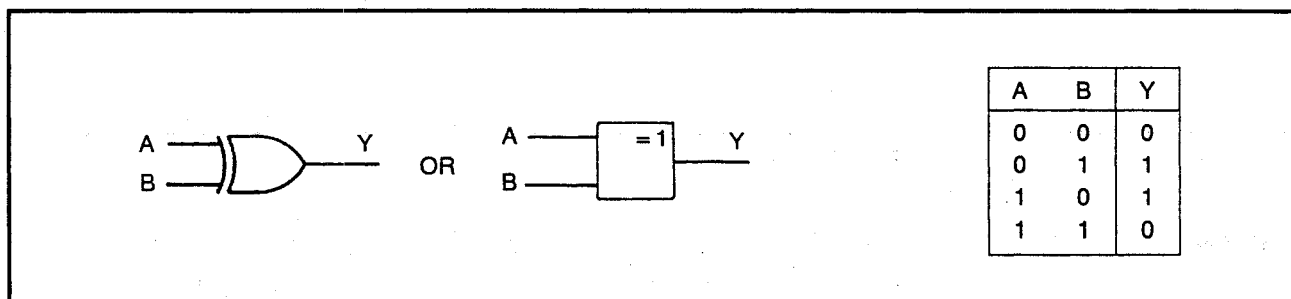


Figure 7: Symbol and truth table for an Exclusive-OR gate

change occurs at its trigger input. This level change can be from 0 to 1 (positive edge trigger) or (negative edge trigger) depending on the particular monostable device or configuration.

Upon receipt of a valid trigger pulse, the output of the monostable changes state to logic 1. Then, after a time interval determined by external C-R timing components, the output reverts to logic 0. The device then awaits the arrival of the next trigger.

**Example**

The most common example of a TTL monostable device is the 74121. This device can be triggered by either positive or negative edges depending upon the configuration employed. The chip has complementary outputs (Q and  $\bar{Q}$ ) and requires only two timing components (one resistor and one capacitor).

**Control Inputs**

Control inputs A1, A2 and B are used to determine the trigger mode and may be connected in any one of the following three ways:

- A1 and A2 connected to logic 0. The monostable then triggers on a negative edge to B.

**3/2****Electronic  
Fundamentals**

3/2 - C

Components

3/2 - C - AC

Active Components

3/2 - C - AC - L

Logic ICs

- A1 and B connected to logic 1. The monostable then triggers on a negative edge applied to A2.
- A2 and B connected to logic 1. The monostable then triggers on a negative edge applied to A1.

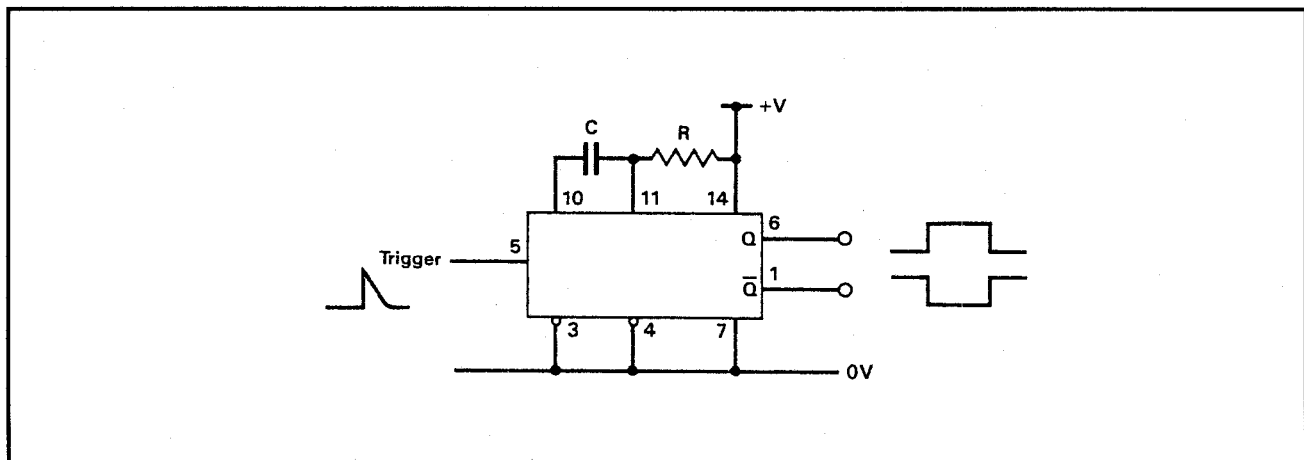
Unlike some other astable types, the 74121 is not re-triggerable during its monostable timing period. This simply means that once a timing period has been started, no further trigger pulse is recognized. In normal use, a recovery time equal in length to the monostable pulse should be allowed before attempting to re-trigger the device.

**Usage**

Monostable devices are often used for stretching pulses of very short duration. A 74121 is an ideal device to perform this function. It is triggered by a very short duration pulse and continues its timing period long after the input signal has reverted to its original state. The only requirement is that, to ensure reliable triggering, the input pulse should have a width of at least of 50 ns.

**Circuit  
Arrangements**

In most practical circuit arrangements (see Figure 8) the values of the external timing resistor should normally lie in the range of 1.5 k $\Omega$  to 47 k $\Omega$ . The minimum recommended value of external capacitor is 10 pF, with the maximum value limited only by the leakage current of the capacitor employed. (In practice, values of several hundred  $\mu$ F are found.)



**Figure 8:** Monostable arrangement based on the 7412

3/2 - C

Components

3/2 - C - AC

Active Components

3/2 - C - AC - L

Logic ICs

## Bistables

The output of a bistable can remain indefinitely in either logical state (0 or 1). Once set, the output will remain the same until reset.

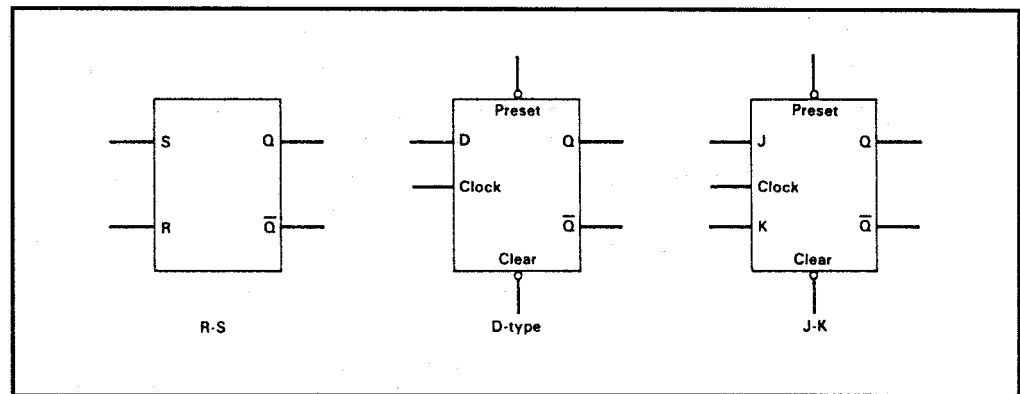


Figure 9: Bistable symbols

Various forms of bistables are found (see Figure 9).

### R-S Bistables

The simplest form of bistable is the R-S bistable. This device has two inputs, SET and RESET, with complementary outputs Q and  $\bar{Q}$ . A logic 1 applied to the SET input causes the Q output to become (or remain at) logic 1, while a logic 1 applied to RESET causes the Q output to become (or remain at) logic 0. In either case, the bistable remains in its set or reset state until an input is applied in a way that changes the logical state.

R-S bistables are sometimes implemented using cross-coupled NAND and NOR gates as shown in Figure 10. These arrangements are, however, unreliable as the output state is indeterminate when S and R are simultaneously at logic 1.

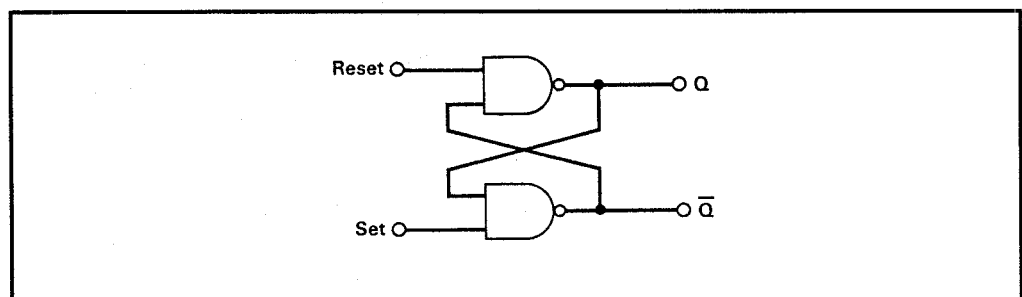


Figure 10: Cross-coupled NAND gate bistable

3/2 - C	Components
3/2 - C - AC	Active Components
3/2 - C - AC - L	Logic ICs

### D-Type Bistables

The D-type bistable has two principal inputs—D (data or delay) and CLOCK (CK). The data input (logic 0 or 1) is clocked into the bistable such that the output state only changes when the clock changes state. Operation is thus said to be synchronous. Additional subsidiary inputs (which are invariably active low) are provided which can be used to directly set or reset the bistable. These are usually called **PRESET** (PR) and **CLEAR** (CLR). D-type bistables are used both as latches (a simple form of memory) and as binary dividers.

### J-K Bistables

J-K bistables have two clocked inputs (J and K), two direct inputs (**PRESET** and **CLEAR**), a **CLOCK** (CK) input, and outputs Q and  $\bar{Q}$ . As with R-S bistables, the two outputs are complementary. That is, when one is 0 the other is 1 and vice versa. Similarly, the **PRESET** and **CLEAR** inputs are both active low (i.e., a 0 on the **PRESET** input sets the Q output to 1, whereas a 0 on the **CLEAR** input will set the Q output to 0).

J-K bistables are the most sophisticated and flexible bistables, and they can be configured as binary dividers, shift registers and latches.

## Logical Levels and Noise Margins

Logic levels are the range of voltages used to represent the logic states 0 and 1. The logic levels for CMOS differ markedly from those associated with TTL.

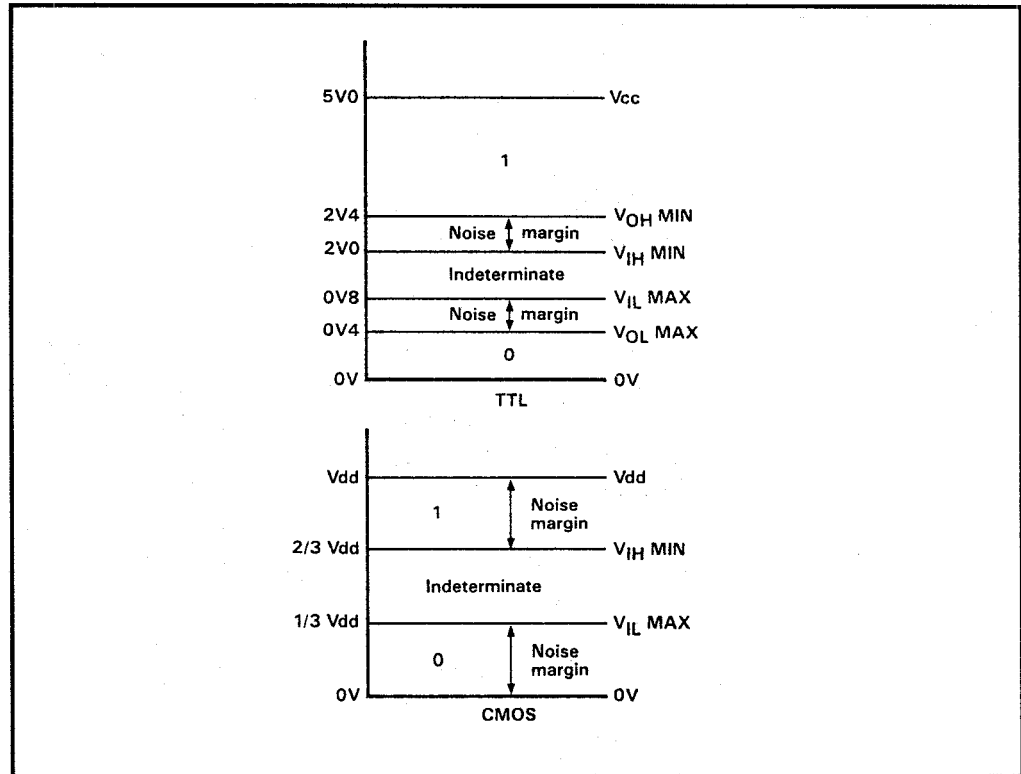
In particular, CMOS logic levels are relative to the supply voltage used while the logic levels associated with TTL devices tend to be absolute (as shown in the following table).

### Logic Levels

	CMOS	TTL
Logic 1	more than $2/3 V_{DD}$	more than 2V
Logic 0	less than $1/3 V_{DD}$	less than 0.8V
Indeterminate	between $1/3 V_{DD}$ and $2/3 V_{DD}$	and between 0.8V and 2V
(Note: $V_{DD}$ is the positive supply associated with CMOS devices.)		

### Noise Margin

The noise margin of a logic device is a measure of its ability to reject noise. The larger the noise margin the better the ability to perform in a noisy environment. Noise margin is defined as the difference between the minimum values of high state output and high state input voltage, and the maximum values of low state output and low state input.



**Figure 11:** Logic levels and noise margins for CMOS and TTL Devices

$$\begin{aligned} \text{Noise margin} &= V_{OH(MIN)} - V_{IH(MIN)} \\ \text{Noise margin} &= V_{OL(MAX)} - V_{IL(MAX)} \end{aligned}$$

That is where  $V_{OH(MIN)}$  is the minimum value of high state (logic 1) output voltage,  $V_{IH(MIN)}$  is the minimum value of high state (logic 1) input voltage,  $V_{OL(MAX)}$  is the maximum value of low state (logic 0) output voltage, and  $V_{IL(MAX)}$  is the maximum value of low state (logic 0) input voltage.

The noise margin for standard 7400 series TTLs is typically 400 mV while that for CMOS is  $1/3 V_{DD}$ , as shown in Figure 11.

### Bus Compatible Devices

Microprocessor bus compatible digital integrated circuits invariably have tri-state outputs. These outputs can be placed in a high impedance state (i.e., are effectively disconnected) in order to avoid bus conflicts that may occur when

3/2 - C	Components
3/2 - C - AC	Active Components
3/2 - C - AC - L	Logic ICs

several logic devices attempt to simultaneously drive the bus. Such devices have a control input called ENABLE (EN) or CHIP SELECT (CS) which allows the device to drive the bus. Such an input may be active high (the output of the gate is valid when the enable or chip select input is taken to logic 1) or active low (the output of the gate is valid when the enable or chip select is taken to logic 0). A small circle is often used to denote an active low enable or chip select input on the device symbol.

**Fan-in and Fan-out** The fan-in of a TTL logic circuit is a measure of the loading effect of its inputs in comparison with a standard TTL gate. A TTL device with a fan-in of two has inputs which are each equivalent to two standard TTL input loads. The fan-out of a logic gate is a measure of its ability to drive further inputs. A TTL device with a fan-out of two is capable of driving two standard TTL input loads. Clearly, at any node in a digital logic circuit, the fan-out of the driving stage must always be greater than, or equal to, the total fan-in of the following stages. For this reason it is essential to ensure that a replacement device has the same (or improved) fan-out.

**Supply Voltages** Most TTL and CMOS logic systems are signed to operate from a single supply voltage rail of nominally +5 V. With TTL devices, this supply rail is invariably regulated. In most cases, the supply voltage should not fall outside the range of 4.75 V to 5.25 V.

CMOS devices can operate over a much wider range of supply voltages (3 V to 15 V), however, when operating at reduced supply voltages it is important to note that the propagation delay (the time taken for a change of state to appear at the output in response to a change at the input) is significantly increased. In order to maintain performance at high switching speeds, it is important to use a relatively high value of supply voltage. This explains why CMOS-based equipment sometimes fails to perform to specification when the supply voltage is, for some reason, lower than normal. CMOS devices generally consume significantly less power than their TTL counterparts. Power consumption for CMOS devices tends to be proportional to switching speeds, whereas for TTL it tends to remain constant. At speeds in excess of several MHz, power consumption may approach, or even exceed, that of a comparable TTL device. Early CMOS devices were easily damaged by stray static charges and required careful handling, particularly during soldering and de-soldering. While modern CMOS devices are fitted with input static protection diodes, care must still be taken.

The absolute maximum supply voltage for TTL devices is nominally 7 V. If the supply voltage ever exceeds this value, any TTL devices connected to the supply are liable to destruct very quickly.

# 3/2

Electronic  
Fundamentals

3/2 - C	Components
3/2 - C - AC	Active Components
3/2 - C - AC - LED	Light Emitting Diodes

## 3/2 - C - AC

### Active Components

## 3/2 - C - AC - LED

### Light Emitting Diodes

#### Basic Function

Light emitting diodes are used for more than just display lights. Used in conjunction with photo-sensitive components, they are terrific sensors. Most commonly they are used as general purpose indicators. Compared with conventional filament lamps and neon indicators, LEDs operate from significantly smaller voltages and currents and are much more reliable. LEDs are available in a variety of colors including red, yellow and green. A typical red LED provides a reasonable amount of light output with a forward current of as little as 10 mA.

Light emitting diodes are available in various formats, with the round types being most common. Round LEDs are available in the 3 mm and 5 mm diameter plastic packages (see Figure 1). Another common format is the 2 mm x 5mm rectangular structure. The viewing angle for round LEDs tends to be in the region of 20° to 40°. With the rectangular types, this is increased to around 100°.

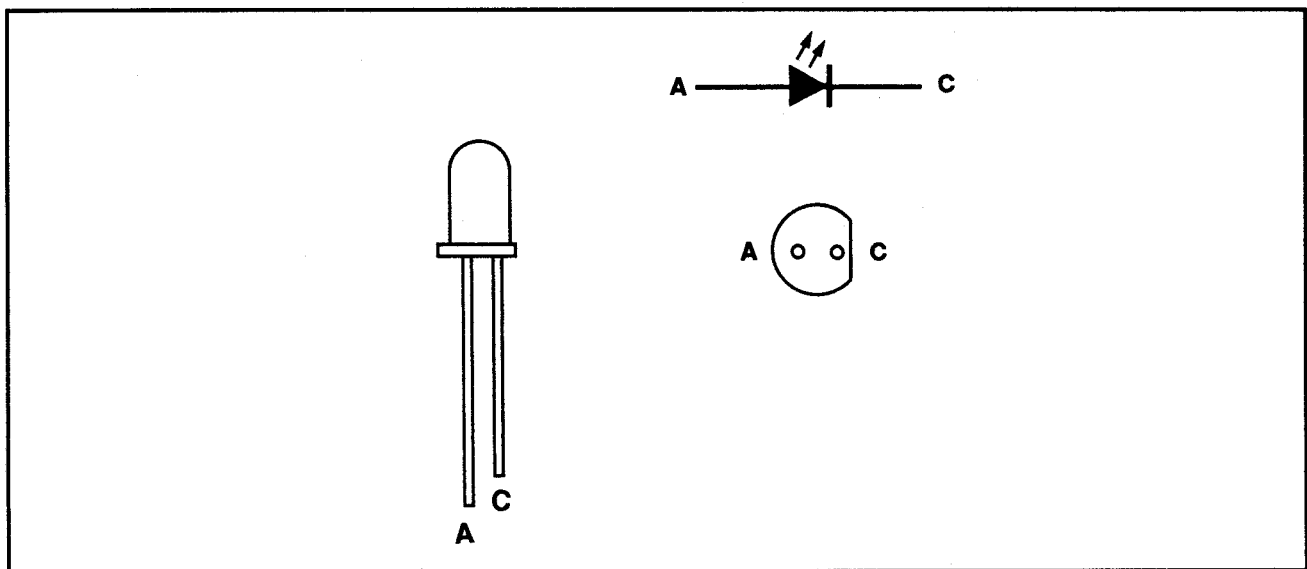


Figure 1: LED symbol and round casings

3/2 - C	Components
3/2 - C - AC	Active Components
3/2 - C - AC - LED	Light Emitting Diodes

Table 1

Parameter	Type of LED			
	standard	standard	high efficiency	high intensity
Diameter (mm)	3	5	5	5
Max. forward current (mA)	40	30	30	30
Typical forward current (mA)	12	10	7	10
Typical forward voltage drop (V)	2.1	2.0	1.8	2.2
Max. reverse voltage (V)	5	3	5	5
Max. power dissipation (mW)	150	100	27	135
Peak wavelength (nm)	690	635	635	635

Typical characteristics for commonly available red LEDs are summarized in Table 1 above.

In order to limit the forward current to an appropriate value, a fixed resistor is connected in series with an LED indicator (Figure 2). The value of the resistor is determined from the formula:

$$R = \frac{V - V_F}{I}$$

where  $V_F$  is the forward voltage drop produced by the LED and  $V$  is the applied voltage.  $V_F$  is usually about 2 V, and the nearest preferred value is used for  $R$ .

Table 1  
Typical Values  
for  $R$

Supply Voltage	Series Resistance ( $I_F = 10$ mA nominal)
3	180
5	270
6	390
9	680
12	1 k
15	1.2 k
18	1.5 k
24	2.2 k

It is important to note that yellow and green LEDs generally give less light for a given current than their standard red counterparts. To maintain an equal light output when several LEDs are used together, different values of series resistors



3/2 - C

Components

3/2 - C - AC

Active Components

3/2 - C - AC - LED

Light Emitting Diodes

may be employed. As a rule of thumb, series resistors for yellow and green LEDs are between 10% and 20% lower than for red LEDs.

Finally, when replacing LEDs, it is very important to avoid inadvertent reverse connection of the device. Reverse voltage in excess of about 5 V will destroy the junction.

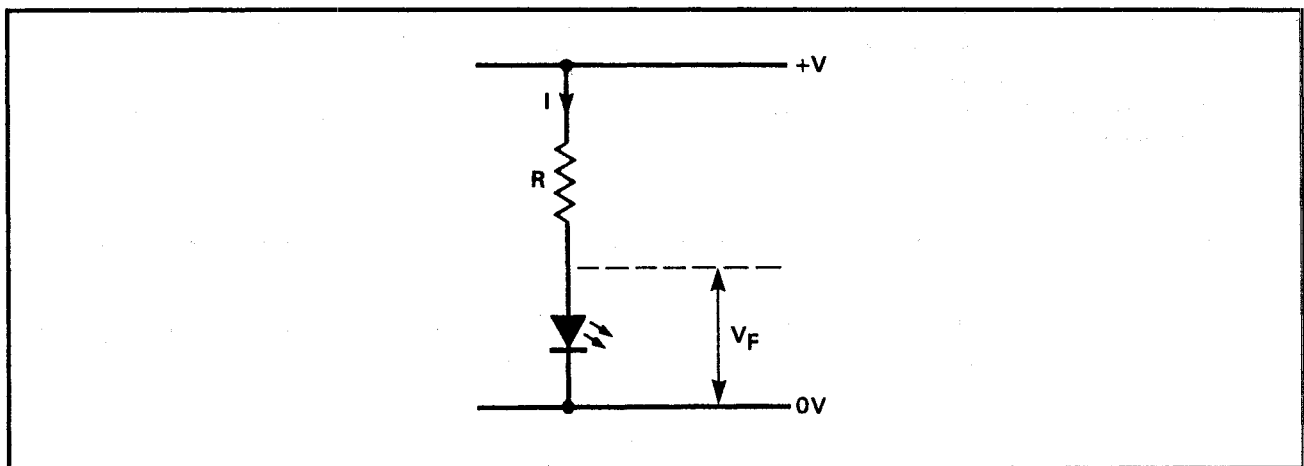


Figure 2: Basic LED circuit

**3/2**  
Electronic  
Fundamentals

3/2 - C	Components
3/2 - C - AC	Active Components
3/2 - C - AC - LED	Light Emitting Diodes

3/2 - C	Components
3/2 - C - AC	Active Components
3/2 - C - AC - OpAmp	Operational Amplifiers

## 3/2 - C - AC

### Active Components

## 3/2 - C - AC -OpAmp

### Operational Amplifiers

#### Basic Function

Operational amplifiers (op-amps) are general purpose integrated circuits with a wide variety of applications. Operational amplifiers can be considered to offer a “block of gain”. As amplifiers they possess near-ideal characteristics (virtually infinite voltage gain and input resistance together with low output resistance and wide bandwidth). The following terminology is applied to operational amplifiers.

#### Open-loop Voltage Gain

This is the ratio of output voltage to input voltage measured without feedback applied. The open-loop voltage gain is given by:

$$A_{VOL} = V_{OUT}/V_{IN}$$

where  $A_{VOL}$  is the open-loop voltage gain,  $V_{OUT}$  and  $V_{IN}$  are the output and input voltages respectively under open-loop conditions. In linear voltage amplifying applications, a large amount of negative feedback is normally applied and the open-loop voltage gain can be thought of as the internal voltage gain provided by the device.

The open-loop voltage gain is sometimes expressed in decibels (dB) rather than as a ratio. In this case:

$$A_{VOL} = 20 \log_{10} (V_{OUT}/V_{IN})$$

#### Closed-loop Voltage Gain

This is the ratio of output voltage to input voltage when negative feedback is applied.

$$A_{VCL} = V_{OUT}/V_{IN}$$

where  $A_{VCL}$  is the closed-loop voltage gain,  $V_{OUT}$  and  $V_{IN}$  are output and input voltages respectively under closed-loop conditions. The closed-loop voltage gain is normally very much less than the open-loop voltage gain.

3/2 - C	Components
3/2 - C - AC	Active Components
3/2 - C - AC - OpAmp	Operational Amplifiers

**Input Resistance**

The input resistance is simply the ratio of input voltage to input current:

$$R_{IN} = V_{IN} / I_{IN}$$

where  $R_{IN}$  is the input resistance,  $V_{IN}$  is the input voltage and  $I_{IN}$  is the input current. Note that the input of an operational amplifier is normally assumed to be purely resistive, though this may not be the case at high frequencies where shunt capacitance may be present.

The input resistance of operational amplifiers is very much dependent on the semiconductor technology employed. In practice, values range from about 2 M $\Omega$  for bipolar operational amplifiers to over 10<sup>12</sup>  $\Omega$  for CMOS devices.

**Output Resistance**

The output resistance is the ratio of open-circuit output voltage to short-circuit output current

$$R_{OUT} = V_{OUT(OC)} / I_{OUT(SC)}$$

where  $R_{OUT}$  is the output resistance,  $V_{OUT(OC)}$  is the output voltage and  $I_{OUT(SC)}$  is the output current.

**Input Offset Voltage**

The input offset voltage is the voltage which when applied at the input provides an output voltage of exactly zero. Similarly, the input offset current is the current which, when applied at the input, provides an output current of exactly zero. (Note that due to imperfect balance and very high internal gain, a small output voltage may appear with no input present.)

Offset may be minimized by applying large amounts of negative feedback or by using the offset null facility provided by certain types of op-amps (Figure 1).

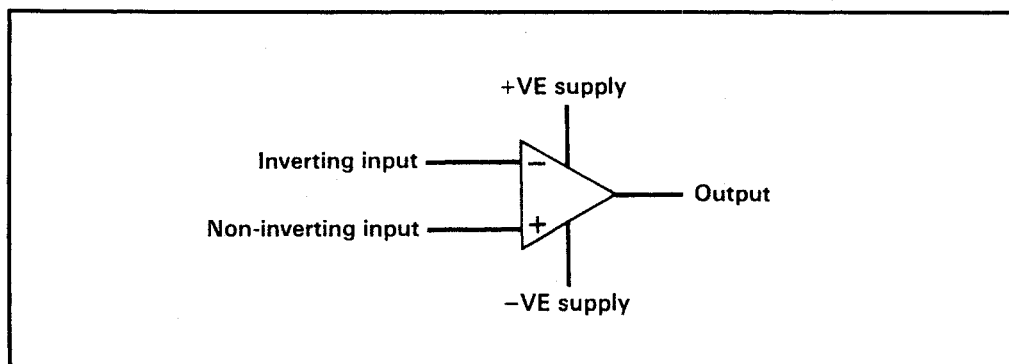


Figure 1: Operational amplifier symbol

# 3/2

Electronic  
Fundamentals

3/2 - C

Components

3/2 - C - AC

Active Components

3/2 - C - AC - OpAmp

Operational Amplifiers

**Slew-rate**

The slew-rate of an operational amplifier is the rate of change of output voltage with time in response to a perfect step-function input. The formula is:

$$\text{Slew-rate} = \Delta V_{\text{OUT}} / \Delta t$$

where  $\Delta V_{\text{OUT}}$  is the change in output voltage and  $\Delta t$  is the corresponding interval of time.

**Common-Mode Rejection Ratio (CMRR)**

This is the ratio of differential voltage gain to common-mode voltage gain (usually expressed in dB):

$$\text{CMRR} = 20 \log_{10} A_{\text{VOL(DM)}} / A_{\text{VOL(CM)}}$$

where  $A_{\text{VOL(DM)}}$  is the voltage gain in differential mode (equal to  $A_{\text{VOL}}$ ) and  $A_{\text{VOL(CM)}}$  is the open-loop voltage gain in common-mode (i.e., signals applied with both inputs connected together). CMRR is a measure of an operational amplifier's ability to reject signals (e.g. noise) which are simultaneously present on both inputs.

**Maximum Output Voltage Swing**

This is the maximum range of output voltages that the device can produce without clipping. The maximum output voltage swing is dependent on the positive and negative supply voltages.

**Bandwidth**

The bandwidth of an operational amplifier is the range of frequencies over which the device is able to provide its rated gain. Bandwidth is closely related to slew-rate in that the greater the slew-rate, the wider the bandwidth.

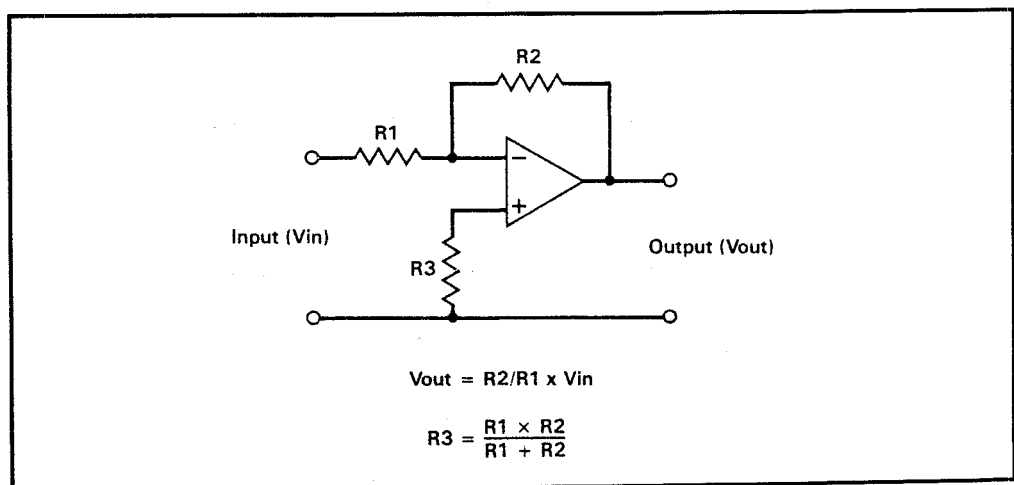


Figure 2: Operational amplifier with feedback

3/2 - C	Components
3/2 - C - AC	Active Components
3/2 - C - AC - OpAmp	Operational Amplifiers

Modern operational amplifiers exhibit very high open-loop voltage gains (e.g., 100,000) coupled with very high input resistances (e.g., 2 M $\Omega$ ). The output resistance of a low-power operational amplifier is usually in the region of 20  $\Omega$  to 100  $\Omega$  while that for a high-power device may be as low as 2  $\Omega$ .

Operational amplifiers are packaged singly, in pairs (dual types) or in fours (quad types). The 081, for example, is a single general purpose BIFET operational amplifier which is also available in dual (082) and quad (084) forms. Op-amps are available in standard bipolar, CMOS and FET technologies. Certain characteristics, such as input resistance, depend on the semiconductor technology used. FET devices, for example, exhibit input resistances which are much larger than their bipolar counterparts.

It is essential that anti-static precautions are observed when handling CMOS and FET input operational amplifiers.

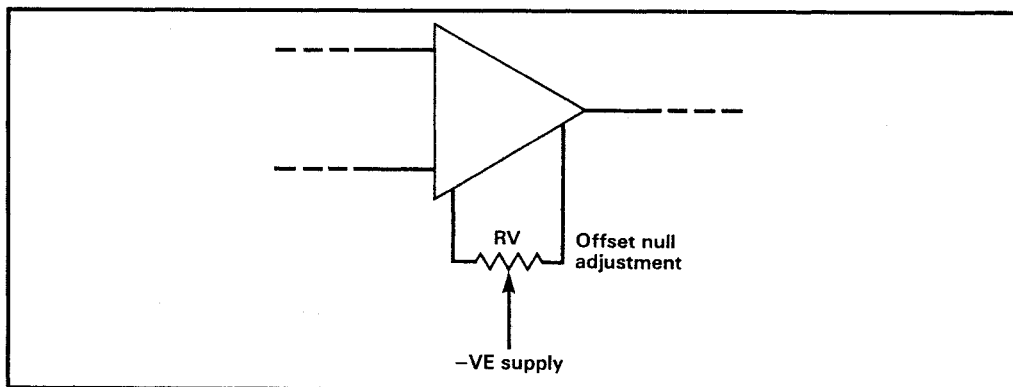


Figure 3: Offset-null facility

# 3/2

Electronic  
Fundamentals

3/2 - C	Components
3/2 - C - AC	Active Components
3/2 - C - AC - T	Transistors

## 3/2 - C - AC

### Active Components

## 3/2 - C - AC - T

### Transistors

An easy way to understand what a transistor is and does is to imagine two diodes connected back-to-back or front-to-front.

**Bipolar Transistors** Bipolar transistors generally comprise P-N-P or N-P-N junctions of either silicon (Si) or germanium (Ge). In either case the electrodes are labeled collector, base and emitter (Figure 2). Silicon transistors are superior when compared with germanium transistors in the vast majority of applications (particularly at high temperatures) and thus germanium devices are very rarely encountered in modern equipment.

Each junction within the transistor, whether it be collector-base or base-emitter, constitutes a P-N junction diode. The base region is, however, made very narrow so that carriers are swept across and a relatively small current flows in the base. The current flowing in the emitter circuit is often 100 or more times greater than that flowing in the base. The direction of current flow is from emitter to collector in the case of a PNP transistor, and collector to emitter in the case of an NPN transistor.

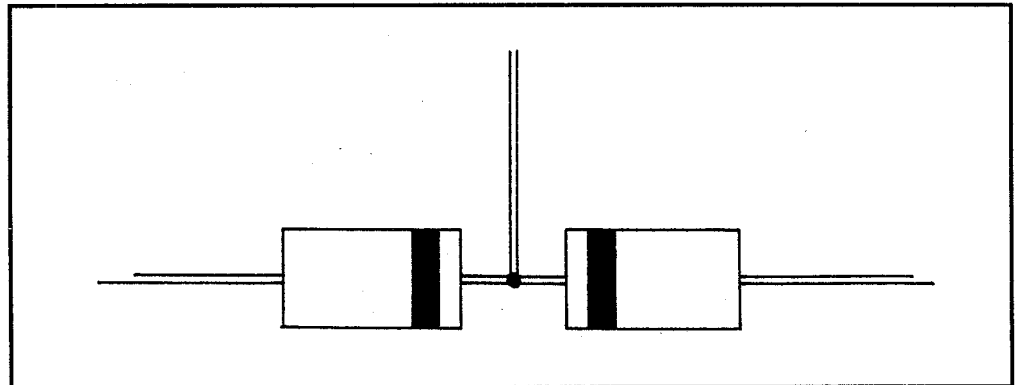
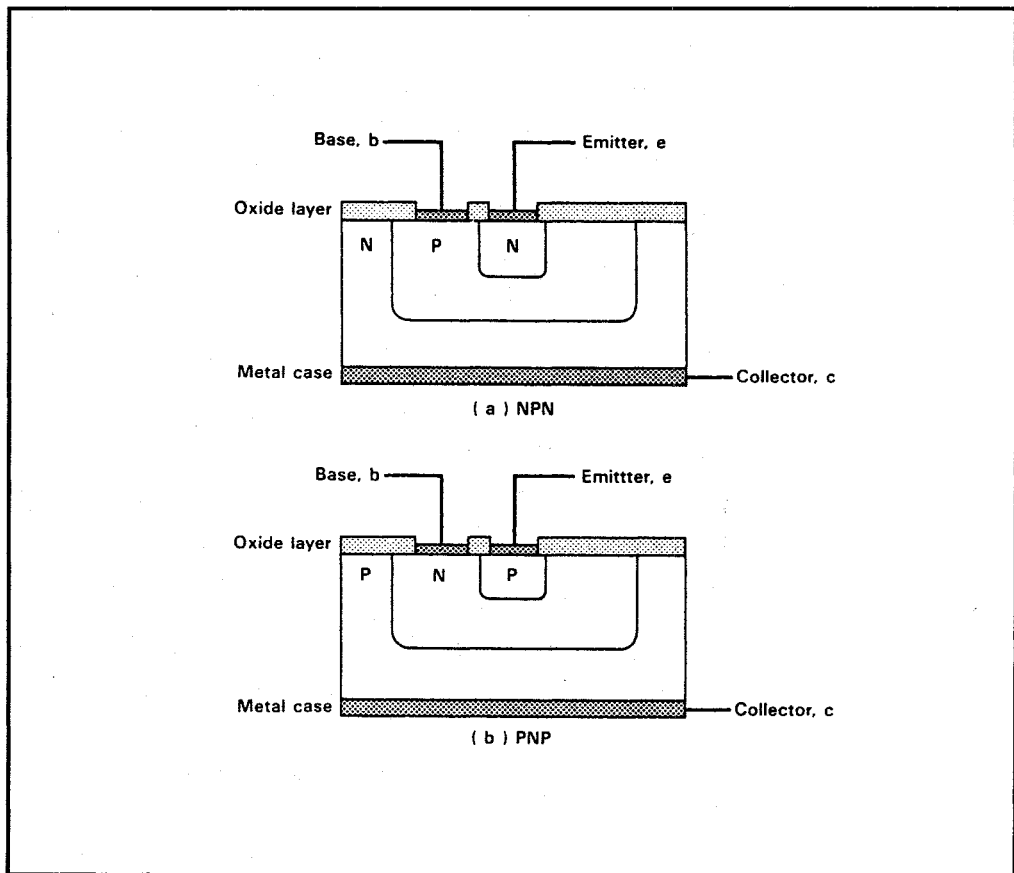


Figure 1: Two diodes back-to-back, compared with a basic transistor



**Figure 2:** NPN and PNP transistors

The equation which relates current flow in the collector, base and emitter currents is:

$$I_E = I_B + I_C$$

where  $I_E$  is the emitter current,  $I_B$  is the base current and  $I_C$  is the collector current.

In transistor circuits designed to provide linear amplification (e.g., AF amplifiers or preamplifiers) a static bias current is applied to the transistor in order to obtain satisfactory operation. This bias is usually applied to the base by means of a single resistor or a potential divider. The base current sets up a corresponding standing current (quiescent current) in the collector circuit. When a signal is applied, this current varies above and below its standing value.

When base current is applied to the transistor, the voltage developed across a forward biased base-emitter junction of a silicon transistor is the same as that



3/2 - C	Components
3/2 - C - AC	Active Components
3/2 - C - AC - T	Transistors

associated with a forward biased diode of the same material. Thus the base-emitter voltage drop for a silicon transistor is in the region of 0.6 V while that for a germanium device is 0.1 V or so. In the case of an NPN device, the base and collector will be positive with respect to the emitter, while for a PNP device the base and collector are negative with respect to the emitter (see Figure 3).

The current gain offered by a transistor is a measure of its effectiveness as an amplifying device. The most commonly quoted parameter is that which relates to common emitter mode. In this mode, the input current is applied to the base and the output current appears in the collector. The emitter is effectively common to both the input and output circuits.

The large-signal (DC) current gain in common emitter mode is thus given by:

$$h_{fe} = I_C / I_B$$

where  $h_{fe}$  is the hybrid parameter which represents large-signal (DC) forward current gain in the common emitter mode,  $I_C$  is the collector current, and  $I_B$  is the base current. When small, rather than large, signal operation is considered, the values of  $I_C$  and  $I_B$  are incremental (i.e., small changes rather than static values).

The small-signal (AC) current gain is then given by:

$$h_{fe} = I_C / I_B$$

where  $h_{fe}$  is the hybrid parameter which represents small-signal (AC) forward current gain,  $I_C$  is the change in collector current which results from a corresponding change in the base current,  $I_B$ .

### Typical Values

Typical values of common emitter current gain ( $h_{fe}$ ) are in the region of 50 to 250.

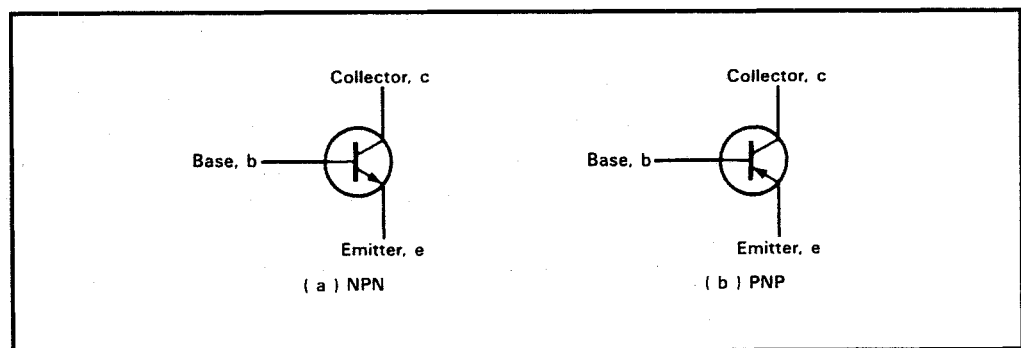


Figure 3: Bipolar transistor connections

3/2 - C	Components
3/2 - C - AC	Active Components
3/2 - C - AC - T	Transistors

Compound Darlington transistors (see Figure 4) are a special form of dual-transistor in which a very high value of forward current gain (typically several thousand) is achieved. Such transistors are often used in the output stages of amplifiers where the high value of  $h_{fe}$  can be used to achieve a very high power gain. Apart from  $h_{fe}$ , other parameters normally quoted by manufacturers often include:

Parameter	Meaning
$I_c$ max.	Maximum value of collector current.
$V_{CEO}$ max.	Maximum value of collector-emitter voltage with the base terminal left open-circuit.
$V_{CBO}$ max.	Maximum value of collector-base voltage with the base terminal left open-circuit.
$P_T$ max.	Maximum power dissipation.
$f_T$ typ.	Transition frequency (i.e., the frequency at which the small signal common-emitter current gain falls to unity.)

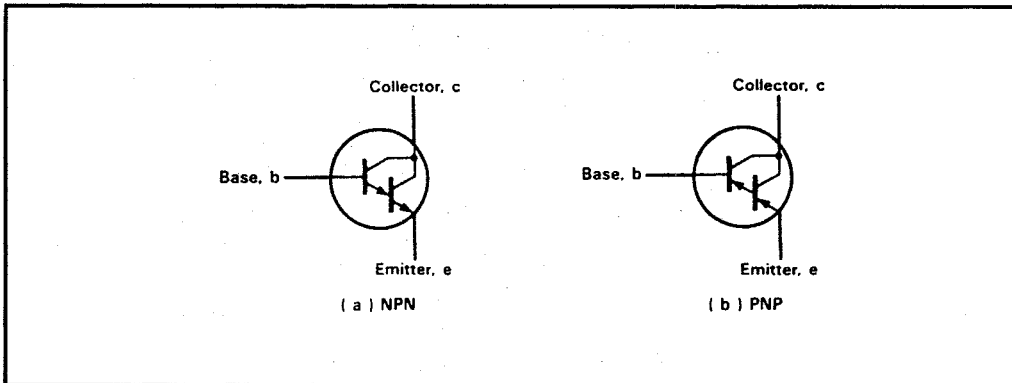


Figure 4: Darlington transistors

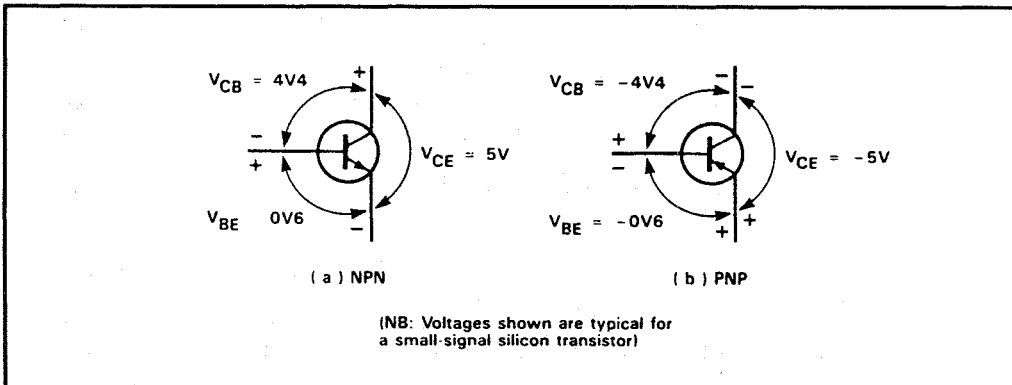


Figure 5: Bipolar transistors potentials, biased for linear operation

# 3/2

Electronic  
Fundamentals

3/2 - C	Components
3/2 - C - AC	Active Components
3/2 - C - AC - T	Transistors

**Transistor Coding** Transistors serve a number of functions and applications. Among these are:

Linear	such as precision voltage or current amplification;
Switching	provides an on or off state;
Power	general amplification, such as for audio or RF;
High-frequency	handling and/or amplifying RF at 100 Hz and above;
Low-frequency	handling and/or amplifying audio signals (below 100 Hz, and often below 50 Hz)
Low noise	used in situations in which distortion must be minimal;
High voltage	used in situations in which high voltage will be present.

As with diodes, several conventions may be used when coding (labeling) transistors. The European system again uses more letters. For example, the British BC140 is the American 2N3109 (which is the same as the 2N3036).

Once again, cross referencing is often necessary, even within a particular system. These guides are available at parts suppliers, through Motorola and even across computers (as above).

## FET Transistors

Field effect transistors (FETs) are made up of a channel of P or N type material surrounded by material of the opposite polarity. The ends of the channel (in which conduction takes place) form electrodes known as the source and drain. The effective width of the channel is controlled by a charge placed on the third (gate) electrode. The effective resistance between the source and drain is thus determined by the voltage present at the gate.

Field effect transistors are available in two basic forms; junction gate and insulated gate. The gate-source junction of a junction gate field effect transistor (JFET) is effectively a reverse-biased P-N junction. On the other hand, the gate connection of an insulated gate field effect transistor (IGFET) is insulated from the channel and charge is capacitively coupled to the channel. IGFETs use either metal on silicon (MOS) or silicon on sapphire (SOS) technology.

JFET devices are less noisy and more stable than comparable IGFET devices. JFET devices offer source input impedance of around 100 M $\Omega$  compared with the 10,000 M $\Omega$  for comparable IGFETs. Note that FET devices offer very much higher input impedances (at the source) than bipolar transistors (at the base). IGFET devices generally offer improved switching characteristics as they

3/2 - C	Components
3/2 - C - AC	Active Components
3/2 - C - AC - T	Transistors

combine low drain-source resistance in the on-state with very high drain-source resistance in the off-state.

IGFETs may be designed for either depletion mode or enhancement mode operation. In the former case, conduction occurs within the channel even when the gate-source voltage (VGS) is zero. In the latter case, a gate-source bias voltage must be applied in order to obtain conduction within the channel. Symbols and connections for various types of JFET and IGFET are depicted in Figure 6.

Linear FET circuits require the application of a bias voltage between the gate and source. The method of applying the bias voltage differs according to the mode of operation (depletion or enhancement). In either case a standing (quiescent) value of drain current results. Typical values of gate-source bias voltage are in the region of  $-2.5\text{ V}$  and  $+2.5\text{ V}$ , according to the mode of operation.

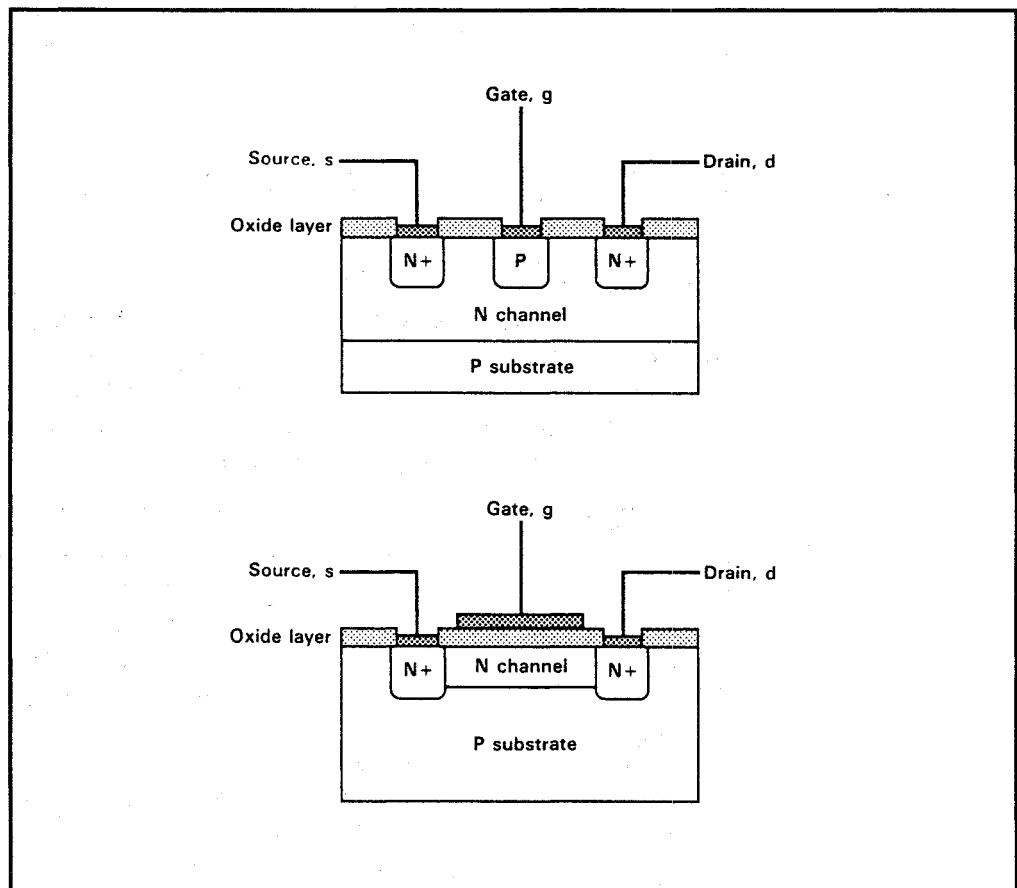


Figure 6: JFET (top) and IGFET (bottom) FETs

3/2 - C

Components

3/2 - C - AC

Active Components

3/2 - C - AC - T

Transistors

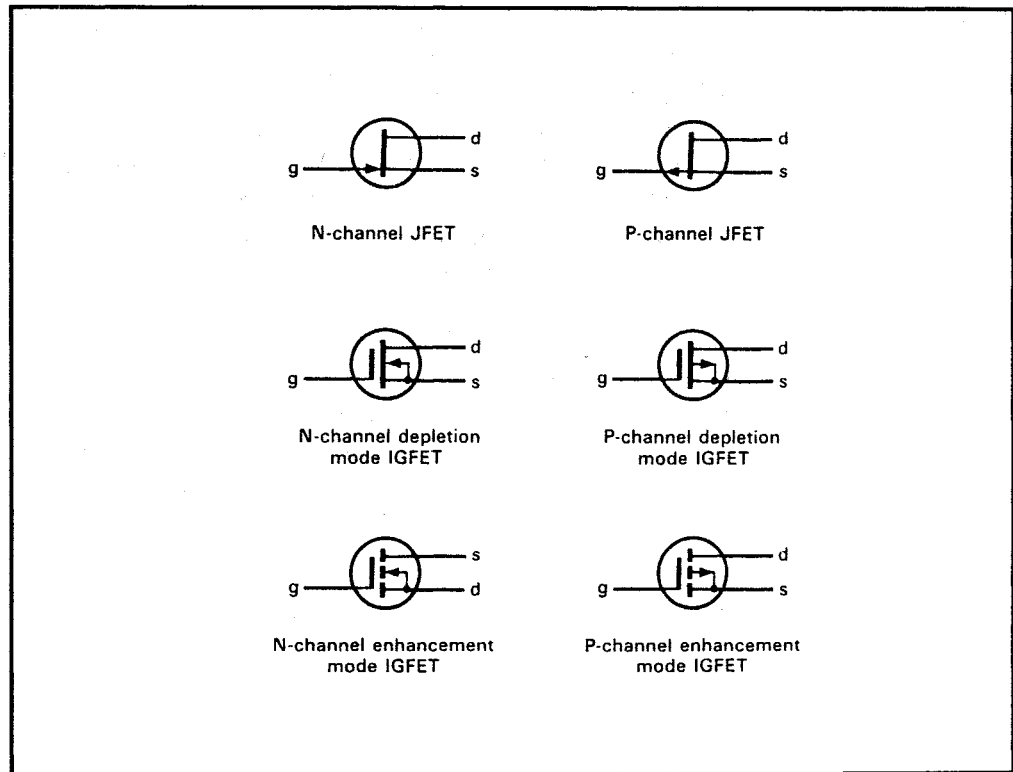


Figure 7: Symbols and connections for various types of FET

**FET Parameters**

The gain offered by a field effect transistor is normally expressed in terms of its forward transfer conductance ( $g_{fs}$  or  $Y_{fs}$ ) in common source mode. In this mode, the input voltage is applied to the gate and the output current appears in the drain, with the source being effectively common to both the input and output circuits. The units of forward transfer conductance are Siemen (S). Other parameters normally quoted by manufacturers include:

Parameter	Meaning
$I_D$ max.	Maximum value of drain current.
$V_{DS}$ max.	Maximum value of drain-source voltage.
$V_{GS}$ max.	Maximum value of gate-source voltage.
$P_D$	Maximum value of drain power dissipation.
$t_r$ typ.	Typical value of output rise-time (in response to a perfect rectangular pulse input).
$t_f$ typ.	Typical value of output fall-time (in response to a perfect rectangular pulse input).
$R_{DS(on)}$ max.	Maximum value of resistance between drain and source when the transistor is in the conducting state (on).

**3/2**  
Electronic  
Fundamentals

3/2 - C	Components
3/2 - C - AC	Active Components
3/2 - C - AC - T	Transistors

**Warning**

*Care should be taken when handling and soldering FET devices, they can be easily damaged by stray static charges. MOSFET devices are particularly prone to static damage and should be handled with extreme care.*

3/2 - C	Components
3/2 - C - AC	Active Components
3/2 - C - AC - Ti	Timers

## 3/2 - C - AC

### Active Components

## 3/2 - C - AC - Ti

### Timers

#### Basic Function

Integrated circuit timers are used in a wide variety of pulse generating applications in almost every branch of electronics. The generic timer is the 555 device. This versatile IC is based on a neat hybrid arrangement of analog and digital circuitry (see Figure 1). The 555 comprises two operational amplifiers (used as comparators) together with an RS bistable element. In addition, inverting output buffer is incorporated so that a considerable current can be sourced to, or sunk from, a load. A single transistor switch (TR1) discharges the external timing capacitor. The standard 555 timer is housed in an 8-pin DIP with the pin connections shown in Figure 2. The device operates on supply volages between 4.5 V and 15 V.

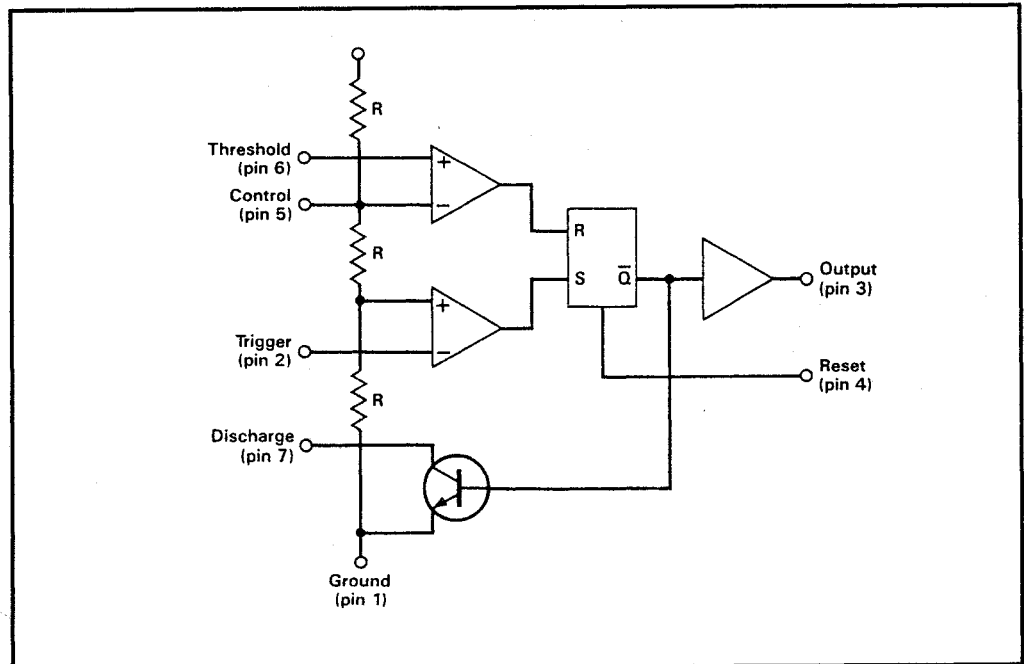
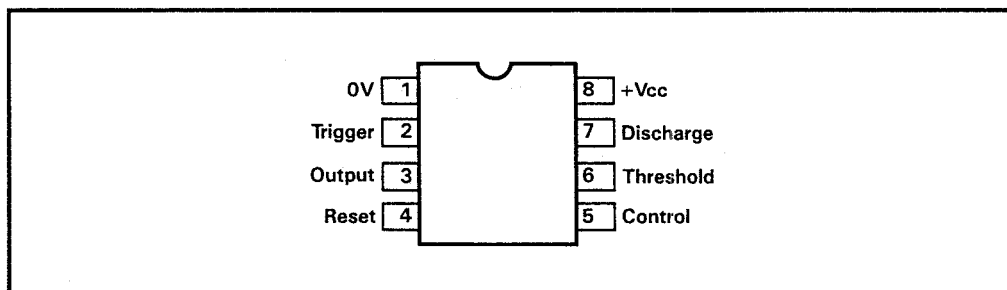


Figure 1: 555 timer

3/2 - C	Components
3/2 - C - AC	Active Components
3/2 - C - AC - Ti	Timers

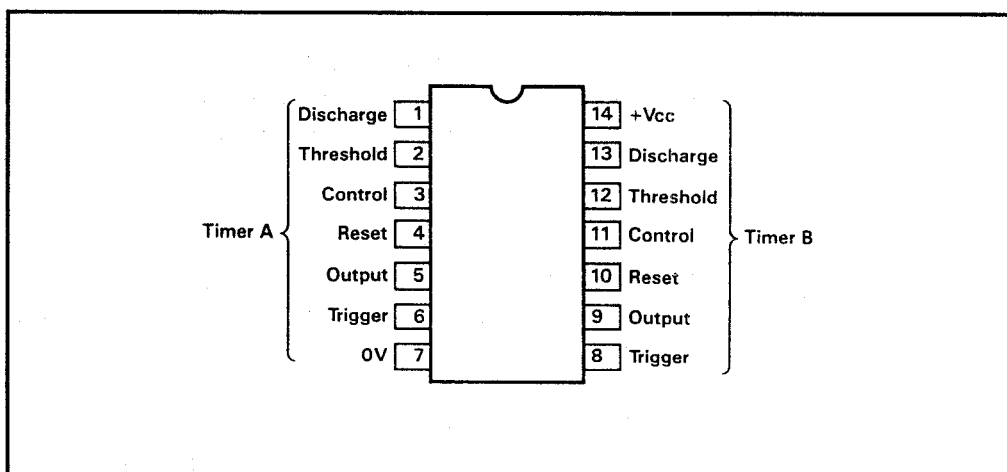


**Figure 2:** 555 timer pin connections

Variants of the 555 are also available. The 556 is a dual 555 device in a 14-pin DIP comprised of two identical independent 555 timers. The pin connections for the 556 are shown in Figure 3. The 555 uses CMOS technology and thus demands on the power supply are minimal.

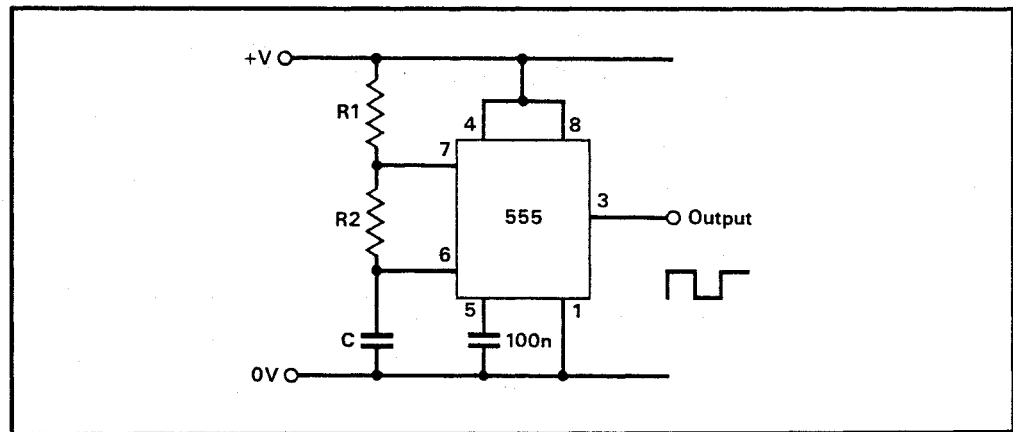
Low-power 555s, such as the ICM7555IPD or the TLC555, are also available. Dual versions of this are the ICM7556IPD and TLC556. These variants employ the same pin connections as their bipolar counterparts.

Timers are used in either astable mode (to generate a continuous pulse train) or in monostable mode (to generate a single pulse of accurately defined length). In astable mode, the range of obtainable pulse repetition frequencies (prf) extends from less than 0.1 Hz (ten seconds per cycle) to over 100 kHz. In monostable modes, pulse durations range from 10  $\mu$ s to 10 s. Accuracy is determined primarily by the external timing components (capacitors and resistors).

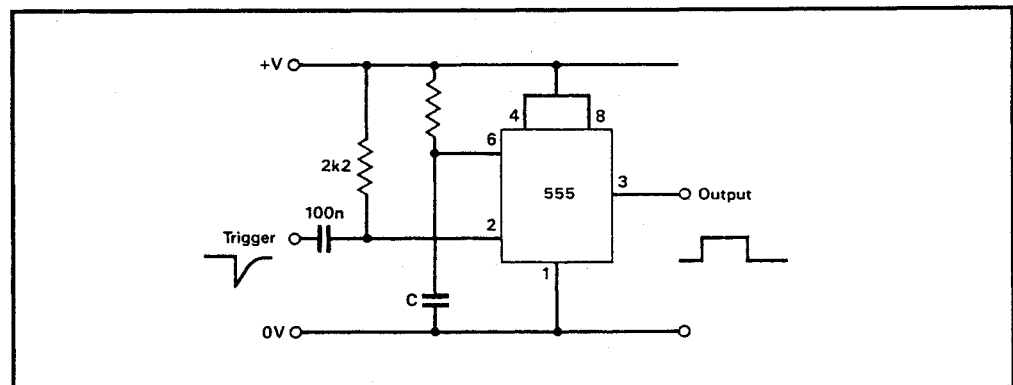


**Figure 3:** 556 dual-timer pin connections





**Figure 4:** Astable pulse generator based on a timer



**Figure 5:** Monostable pulse generator based on a timer

Low-power timers (e.g., CMOS 555, with up to 200 mA for a standard 555) are not capable of delivering substantial levels of output current. CMOS devices can, however, deliver sufficient current to support the connection of up to two TTL loads.

Since the 555 timer is capable of switching appreciable currents rapidly, local decoupling capacitors are usually fitted near a timer device. In many applications, an electrolytic capacitor of 10  $\mu\text{F}$  or 47  $\mu\text{F}$  is fitted close to pin-8 of the standard 555.

An astable pulse generator based on a 555 timer is shown in Figure 4. The output waveform has a period determined by C, R1 and R2, and has an amplitude that is approximately equal to the supply voltage.

3/2 - C	Components
3/2 - C - AC	Active Components
3/2 - C - AC - Ti	Timers

## Output Waveform Characteristics

Time for which output is high:

$$t_{ON} = 0.693 (R1 + R2) C$$

Time for which output is low:

$$t_{OFF} = 0.693 R2 C$$

Period of output:

$$t = t_{ON} + t_{OFF} = 0.693 (R + 2R2) C$$

Prf of output

$$f_P = \frac{1.44}{(R1 + 2R2) C}$$

Mark to space ratio of output:

$$\frac{t_{ON}}{t_{OFF}} = \frac{R1 + R2}{R2}$$

Duty cycle of output:

$$\frac{t_{ON}}{t_{ON} + t_{OFF}} = \frac{R1 + R2}{R1 + 2R2} \cdot 100\%$$

As an example, an astable timer has  $R1 = R2 = 10 \text{ k}\Omega$  and  $C = 220 \text{ nF}$ . The square wave produced by this arrangement has a frequency which is:

$$\begin{aligned}
 f_P &= \frac{1.44}{(R1 + 2R2) C} \\
 &= \frac{1.44}{[10 \text{ k}\Omega + (2 \times 10 \text{ k}\Omega)] \times 220 \text{ nF}} \\
 &= \frac{1.44}{30 \times 10^3 \times 220 \times 10^{-9}} \\
 &= \frac{1.44}{30 \times 220} \times 10^6 \\
 &= \frac{1.44}{6600} \times 10^6 \\
 &= 0.000218 \times 10^6 \\
 &= 218 \text{ Hz}
 \end{aligned}$$

3/2 - C	Components
3/2 - C - AC	Active Components
3/2 - C - AC - TI	Timers

the mark to space ratio of the output waveform will be given by:

$$\begin{aligned}
 t_{ON}/t_{OFF} &= \frac{R1 + R2}{R2} \\
 &= \frac{10 \text{ k}\Omega + 10 \text{ k}\Omega}{10 \text{ k}\Omega} \\
 &= \frac{20 \text{ k}\Omega}{10 \text{ k}\Omega} \\
 &= 2
 \end{aligned}$$

A monostable pulse generator based on a 555 timer is shown in Figure 5. The monostable timing period is initiated by a falling edge (i.e., a high to low transition) applied to the trigger input. When such an edge is received and the trigger input voltage falls below 1/3 of the supply voltage, the 555 output at pin 3 goes high and the monostable pulse is generated for a period determined by the time constant  $C \times R$ . The amplitude of the pulse is approximately equal to the supply voltage. The output pulse has the following characteristics:

Period for which the output is high:

$$t_{ON} = 1.1 R C$$

Recommended trigger pulse width:

$$t_{TR} < 0.25 t_{ON}$$

As an example, a monostable timer operates with  $C = 100 \text{ nF}$  and  $R = 47 \text{ k}\Omega$ . The duration of the monostable pulse output is:

$$\begin{aligned}
 t_{ON} &= 1.1 R C \\
 &= 1.1 \times 47 \text{ k}\Omega \times 100 \text{ nF} \\
 &= 1.1 \times 47 \times 10^3 \times 100 \times 10^{-9} \\
 &= 5170 \times 10^{-6} \\
 &= 5.170 \text{ ms}
 \end{aligned}$$

**3/2**  
Electronic  
Fundamentals

3/2 - C	Components
3/2 - C - AC	Active Components
3/2 - C - AC - Ti	Timers

3/2 - C	Components
3/2 - C - AC	Active Components
3/2 - C - AC - Thy	Thyristors

## 3/2 - C - AC

### Active Components

## 3/2 - C - AC - Thy

### Thyristors

#### Basic Function

Thyristors are silicon controlled rectifiers with three terminals that can be used for switching and controlling AC power. Thyristors can switch very rapidly from a conducting state to a nonconducting state. In the off state (nonconducting) the thyristor has negligible leakage current while in the on state (conducting), the device exhibits very low resistance. This results in very little power loss within the thyristor even when appreciable power levels are being controlled. Once switched into the conducting state, the thyristor remains conducting (i.e., it is latched in the on state) until the forward current is removed from the device. In DC applications this necessitates the interruption (or disconnection) of the supply before the device can be reset into its non-conducting state. Where the device is used with an alternating supply (e.g., AC), the device can automatically become reset whenever the main supply reverse. The device can then be triggered on the next half-cycle having the correct polarity to permit conduction. Like their conventional silicon diode counterparts, thyristors have anode and cathode connections. Control is applied by means of a gate terminal (see Figure 1). The device is triggered into the conducting (on) state by means of the application of a current pulse of sufficient amplitude to this terminal.

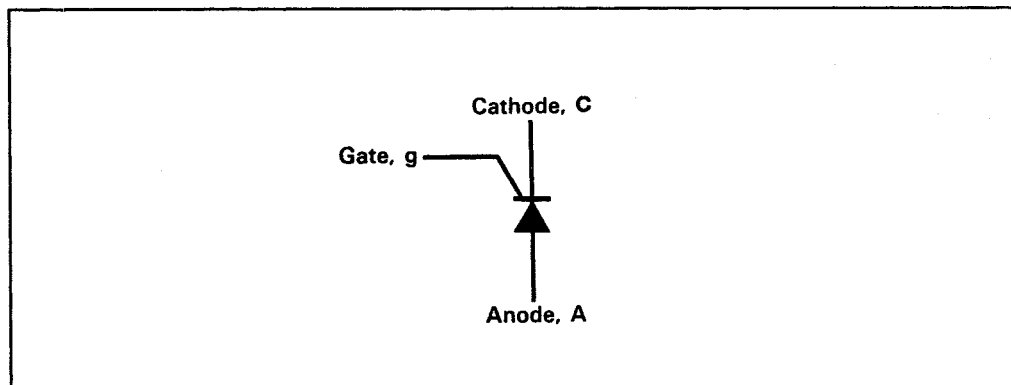


Figure 1: Thyristor symbol and terminal connections

3/2 - C	Components
3/2 - C - AC	Active Components
3/2 - C - AC - Thy	Thyristors

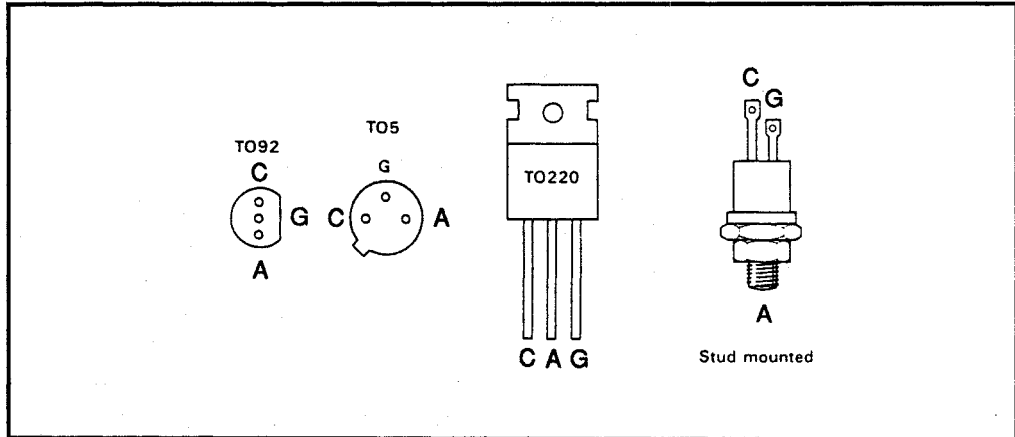


Figure 2: Thyristor casings

Table 1  
Thyristor Data

Type	$I_F$ (AV) Amps	$V_{RRM}$ Volts	$V_{GT}$ Volts	$I_{GT}$ mA
2N4443	5.1	400	1.5	30
2N4444	5.1	600	1.5	30
BT106	1	700	3.5	50
BT152	13	600	1	32
BTX18-400	1	500	2	5
BTY79-400R	6.4	400	3	30
BTY79-600R	6.4	600	3	30
BTY79-800R	6.4	800	3	30
TIC106A	3.2	100	1.2	200µA
TIC106B	3.2	200	1.2	200µA
TIC106C	3.2	300	1.2	200µA
TIC106D	3.2	400	1.2	200µA
TIC106E	3.2	500	1.2	200µA
TIC106M	3.2	600	1.2	200µA
TIC106S	3.2	700	1.2	200µA
TIC106N	3.2	800	1.2	200µA
TIC116A	5	100	2.5	20
TIC116B	5	200	2.5	20
TIC116C	5	300	2.5	20
TIC116D	5	400	2.5	20
TIC116E	5	500	2.5	20
TIC116M	5	600	2.5	20
TIC116S	5	700	2.5	20
TIC116N	5	800	2.5	20
TIC126A	7.5	100	2.5	20
TIC126B	7.5	200	2.5	20
TIC126C	7.5	300	2.5	20
TIC126D	7.5	400	2.5	20
TIC126E	7.5	500	2.5	20
TIC126M	7.5	600	2.5	20
TIC126S	7.5	700	2.5	20
TIC126N	7.5	800	2.5	20
TIC106D	2	400	1	200µA
TIC106M	2	600	1	200µA

3/2 - C	Components
3/2 - C - AC	Active Components
3/2 - C - AC - Thy	Thyristors

Figure 2 shows the details of the casing and connections commonly used with thyristors.

Thyristors may fail in one of several ways, including short or open circuit failure between anode and cathode. In either case, the fault can be readily detected by removing the device from the circuit and applying it to an ohmmeter. Thyristors can be checked for correct triggering by applying a 9 V battery connected in series with a switch and a 220  $\Omega$  resistor between the gate and cathode. An ohmmeter on a low-resistance range connected between the anode and cathode (with the probe connected to the anode) indicates low-resistance when the thyristor is triggered on, and high-resistance when it is off. Note that once triggered, the thyristor should remain on (conducting) when the gate circuit is broken, and that it is necessary to disconnect the ohmmeter to reset the thyristor into its original untriggered state.

**Warning**

*Thyristors are often used in high-voltage and AC mains power control applications. When connecting or disconnecting such devices it is essential to ensure that the equipment is switched off and that the AC mains are completely disconnected.*

**3/2**

**Electronic  
Fundamentals**

<b>3/2 - C</b>	<b>Components</b>
<b>3/2 - C - AC</b>	<b>Active Components</b>
<b>3/2 - C - AC - Thy</b>	<b>Thyristors</b>



3/2 - C	Components
3/2 - C - AC	Active Components
3/2 - C - AC - Tr	Triacs

## 3/2 - C - AC

### Active Components

## 3/2 - C - AC - Tr

### Triacs

#### Basic Function

Triacs are a refinement of the thyristor which, when triggered, conducts on both positive and negative half-cycles of the applied voltage. Triacs have three terminals known as main terminal one (MT1), main terminal two (MT2) and gate (G), as shown in Figure 1. Triacs can be triggered by positive and negative voltages applied between G and MT1 with positive and negative voltages present at MT2 respectively. Triacs thus provide full-wave control and offer superior performance in AC power control applications when compared with thyristors (which only provide half-control).

In order to simplify the design of triggering circuits, triacs are often used in conjunction with diacs (the equivalent of a bi-directional zener diode). A typical diac conducts heavily when the applied voltage exceeds approximately  $\pm 32$  V. Once in the conducting state, the resistance of the diac falls to a very low value and thus a large current will flow. Like their half-wave counterparts, triacs can switch appreciable values of current very rapidly. The switching action generates spikes which are carried for some distance along the supply lines. Spikes can also be radiated from wiring and may cause an appreciable level of RF noise which may affect radio reception over some distance. In many applications, a simple L-C filter (typically based on a 100 nF capacitor and a couple of small ferrite-cored inductors) is incorporated in the main supply connection to prevent noise

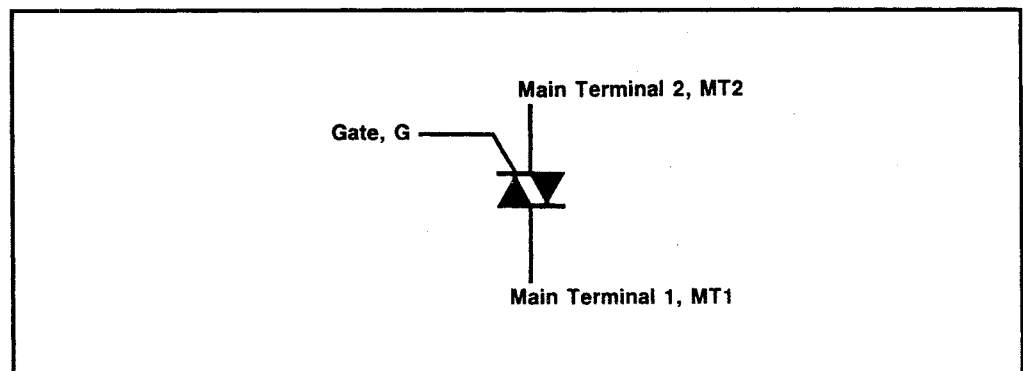


Figure 1: Triac symbol and connections

3/2 - C

Components

3/2 - C - AC

Active Components

3/2 - C - AC - Tr

Triacs

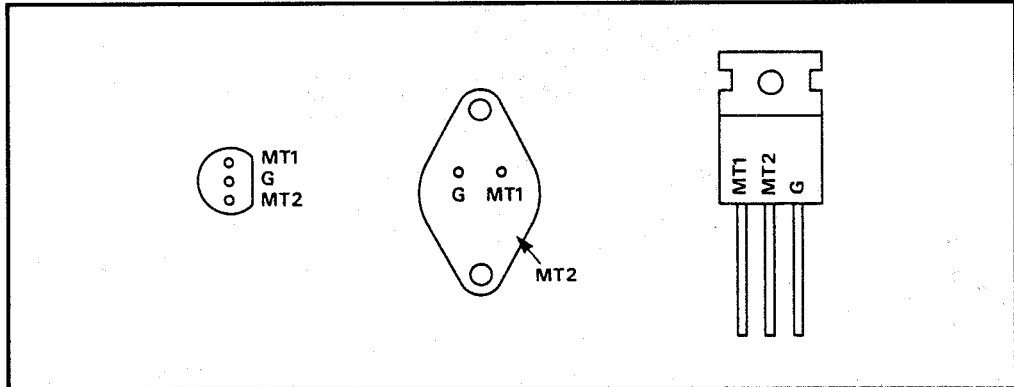


Figure 2: Triac casings and terminals

radiation. Such filters can be subject to considerable loading, and failure of the capacitor or inductor is not uncommon. The filter capacitor normally fails in a short-circuit condition. Rarely does it go open-circuit. This causes the main fuses to blow. Alternatively, when the fuse does not blow (or is of a too large value), the inductor itself may become an open circuit due to the excessive current which flows when the capacitor fails. Damage in this area is usually easy to spot. The offending component(s) will be discolored due to overheating.

Table 1  
Triac Data

Type	$I_{T(RMS)}$ amps	$V_{RMM}$ volts	VGT volts	IGT(TYP) mA
BT139	15	600	1.5	5
TIC206M	4	600	2	5
TIC216M	6	600	3	5
TIC225M	8	600	2	20
TIC226M	8	600	2	50
TIC236M	12	600	2	50
TIC246M	16	600	2	50
TICP206D	1.5	400	2.5	2.5
TICP206M	1.5	600	2.5	2.5

Triacs may fail in one of several ways, including short or open circuit failure between MT1 and MT2, or between gate and either main terminal. Faults can usually be detected by removing the device from the circuit and testing it with an ohmmeter. The procedure described for testing thyristors in Section "3/2 - C - AC - Thy" should be followed, substituting MT1 and MT2 for anode and cathode (respectively), and checking that the device operates correctly when the battery and ohmmeter leads are reversed.

**Warning**

*Triacs are often used in high-power applications and AC main supply lines. When connecting or disconnecting such devices, make sure that the equipment is switched off and that the AC power is disconnected.*

# 3/2

Electronic  
Fundamentals

3/2 - C	Components
3/2 - C - AC	Active Components
3/2 - C - AC - VR	Voltage Regulators

## 3/2 - C - AC

### Active Components

## 3/2 - C - AC - VR

### Voltage Regulators

#### Basic Function

There was a time when components in a circuit could withstand fairly large ranges from the designed center. If the voltage coming to the device varied by a few volts, not much would happen.

To a large extent this is still true. The light bulb in your home is designed to operate at a nominal 117 VAC. If the voltage drops to 110 VAC or even 100 VAC, the lamp will continue to operate. The same is true if the voltage increases to 125 VAC.

This kind of tolerance isn't possible with many discrete components today. A variance of just 1/2 of a volt can cause the component to change its characteristics or to fail entirely.

As a case in point, not that many years ago, discrete components such as resistors had a 10-20% tolerance. Today a 5% tolerance is standard. The reason is that even fractions of a volt have become meaningful.

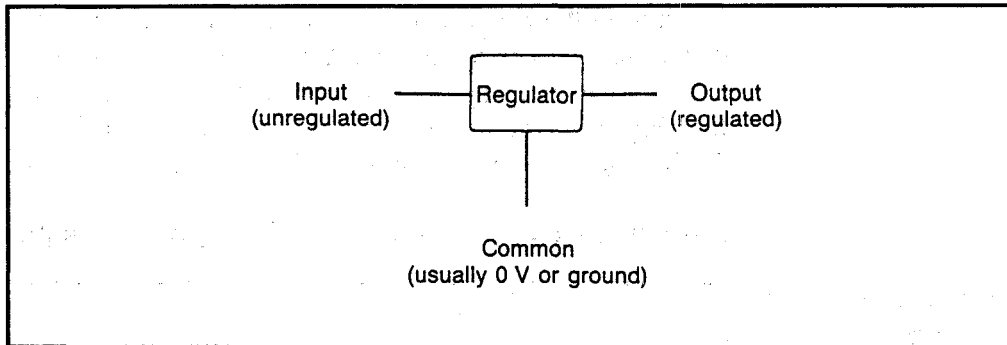
Voltage regulators are integrated circuits designed specifically for use in power supply applications where a constant voltage (or constant current) is required. Regulators are often fitted to low-voltage, stabilized DC power supplies and effectively replace a number of discrete components (transistors, resistors and capacitors).

Regulators are available in two basic forms: variable and fixed. Fixed regulators are more common and provide a fixed output voltage within fairly close tolerance limits (e.g., 5%) over a wide variation in load current. Many regulators are described as three-terminal since they require only three connections to a circuit. Their connections are simply referred to as input, output and common (see Figure 1).

Regulators invariably incorporate means to limit the output current to a specified value (e.g. 1 A). This current limiting facility ensures that in the event of a

**3/2**  
Electronic  
Fundamentals

3/2 - C	Components
3/2 - C - AC	Active Components
3/2 - C - AC - VR	Voltage Regulators



**Figure 1:** Voltage regulator symbol

component failure in the load circuit, the regulator or power supply is not damaged by excess current. In addition, most modern regulators incorporate thermal shut-down circuitry which prevents over-dissipation of the device due to excessive load currents or inadequate heat-sinking provision.

The following data refers to a range of commonly available fixed voltage regulators.

**Table 1**  
**Example Voltage**  
**Regulators**

Device	Output (volts)	Output (amps)
7805	+5	1
7905	-5	1
7809	+9	1
7909	-9	1
7812	+12	1
7912	-12	1
7815	+15	1
7915	-15	1
7824	+24	1
7924	-24	1
78L05	+5	0.1
79L05	-5	0.1
78L12	+12	0.1
79L12	-12	0.1
78L15	+15	0.1
79L15	-15	0.1
78S05	+5	2
78D12	+12	2
78S15	+15	2
78S24	+24	2
78T05	+5	3
78T12	+12	3
78T15	+15	3
78H05	+5	5
78H12	+12	5

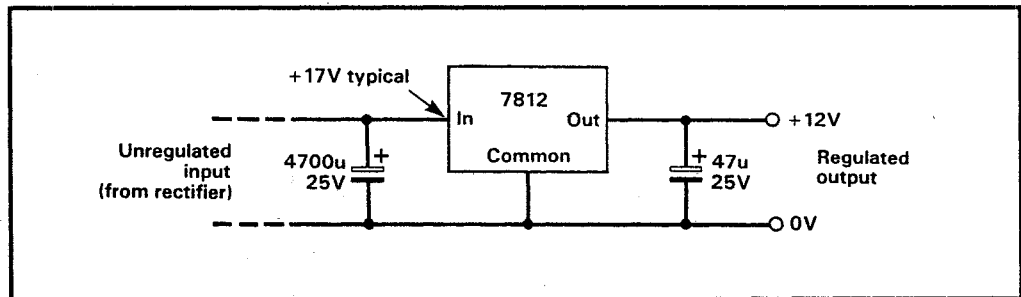
**3/2**  
Electronic  
Fundamentals

3/2 - C	Components
3/2 - C - AC	Active Components
3/2 - C - AC - VR	Voltage Regulators

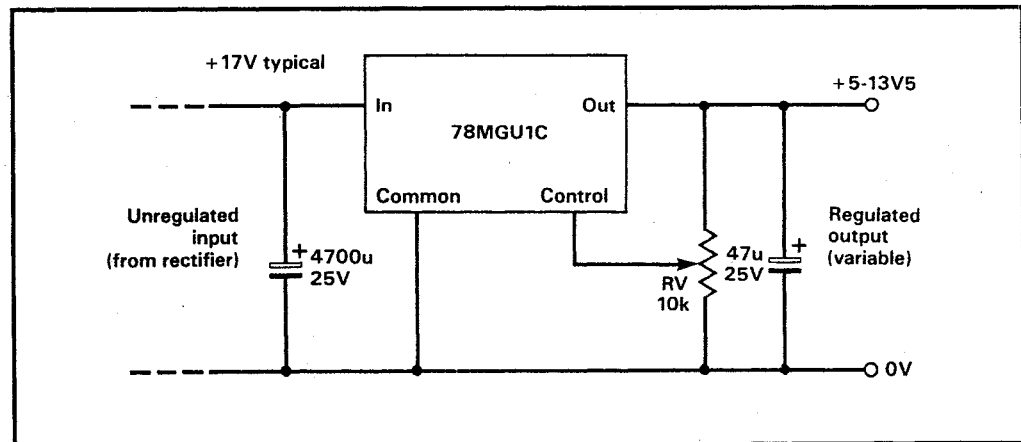
Variable voltage regulators require additional external components (such as preset or variable resistors) to determine the output voltage (see Figure 2). In some applications, the output voltage is fixed by a fixed potential divider arrangement (see Figure 3). This technique is used to provide a fixed stabilized voltage (e.g., 7.5 V) that is unobtainable using the standard range of fixed voltage regulators.

It is important to note that despite their apparent simplicity, voltage regulators

**Voltage Regulator Circuits**



**Figure 2:** Fixed voltage regulator circuit



**Figure 3:** Variable voltage regulator circuit

have considerable internal gain and, to ensure unconditional high-frequency stability, circuits often incorporate low value (e.g. 100 nF) capacitors fitted between input and ground and/or between output and ground (see Figure 5).

These capacitors are most effective when positioned as close as possible to the voltage regulator pins. If a regulator has to be repositioned, it may be necessary to relocate these important decoupling components. Instability in a voltage regulator can usually be detected by erratic behavior (e.g. fluctuation in output voltage, premature shut-down or current limiting). In most applications, voltage

3/2 - C

Components

3/2 - C - AC

Active Components

3/2 - C - AC - VR

Voltage Regulators

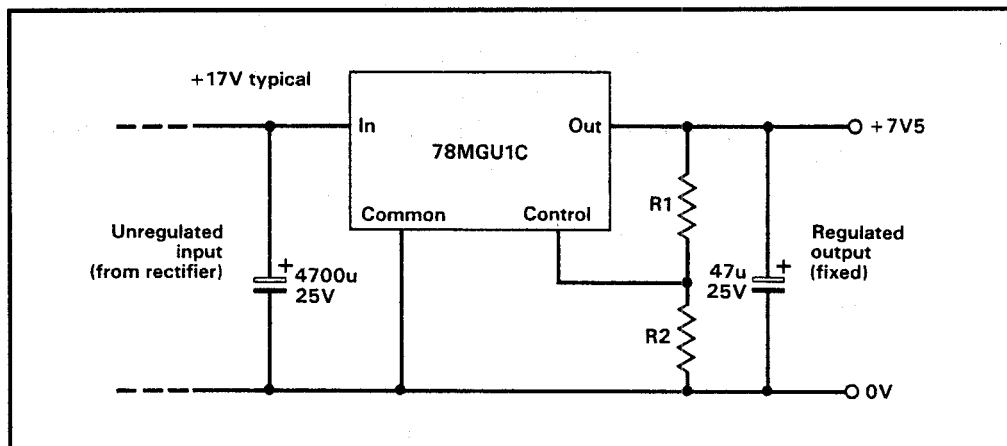


Figure 4: Variable voltage regulator with fixed output voltage

Table 1

Device	min. (V)	Output voltage max. (V)	Output current (A)	Notes
723C	2.0	37		Normally used with an external transistor
L200	2.9	36	2	
L296	5.1	40	4	Switched mode
L460	5.1	40	2.5	Switched mode
LM317LZ	1.2	37	0.1	
LM317MP	1.2	37	0.5	
LM317T	1.2	37	1.5	
LM317K	1.2	37	1.5	
LM338K	1.2	32	5	
LM396K	1.2	15	10	
78MGU1C	5.0	30	0.5	
79MGU1C	-2.2	-30	1	

regulators operate at appreciable power levels. It is essential to provide adequate heat sinking. Failure to observe this precaution may result in premature current limiting or output voltage foldback due to thermal shutdown. When replacing a regulator IC, it is necessary to ensure that the replacement device is correctly fitted to the heat sink. This often requires the use of a heat sink compound.

When troubleshooting power supplies, most regulators require a minimum of 2 V differential between input and output voltages in order for the device to operate correctly. This means that if the voltage regulator is fitted in a 12 VDC power

**3/2**  
Electronic  
Fundamentals

3/2 - C	Components
3/2 - C - AC	Active Components
3/2 - C - AC - VR	Voltage Regulators

supply, it must be supplied with at least 14 VDC of raw (unregulated) input under all conditions. This fact explains why some power supplies perform badly when operated at near full-load, as the transformer/rectifier arrangement may be unable to deliver sufficient voltage to give the regulator sufficient “headroom” to operate.

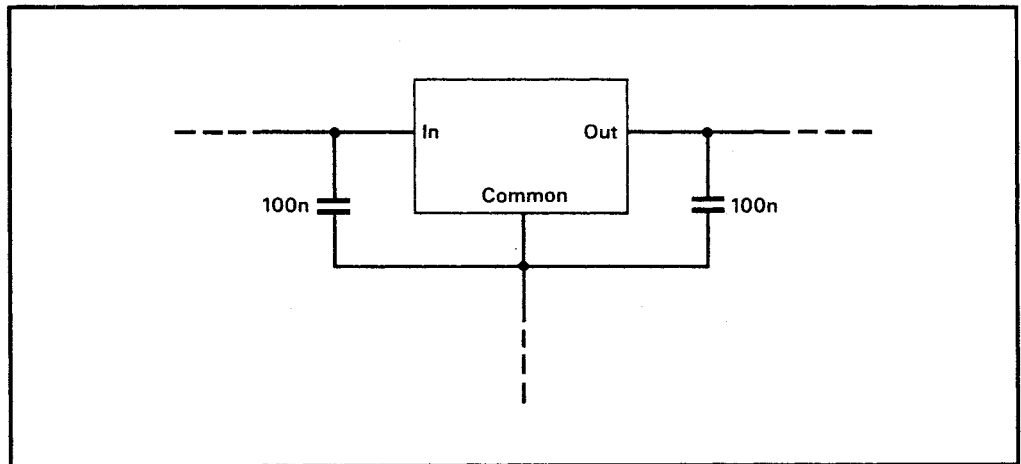


Figure 5: High frequency decoupling

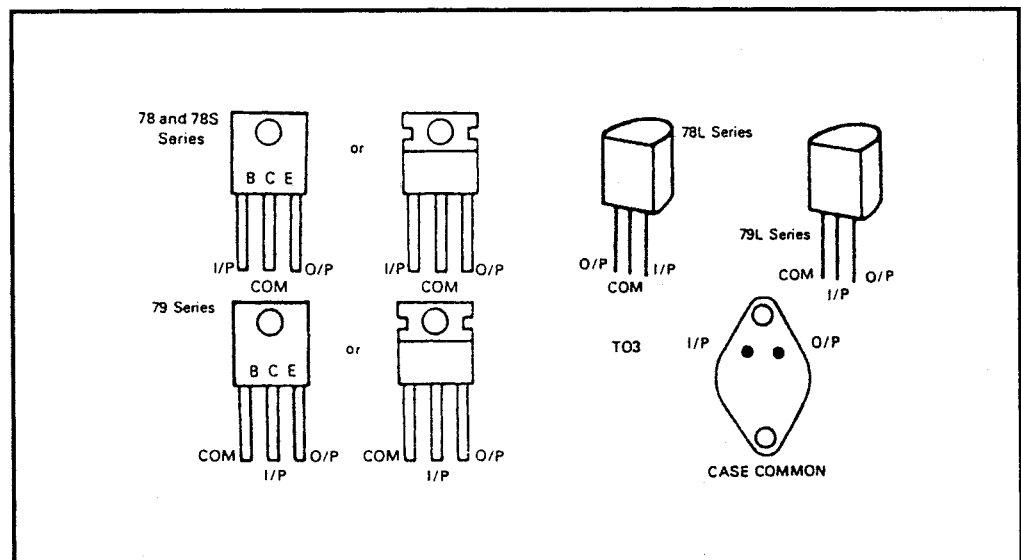


Figure 6: Voltage regulator casings and terminals

**3/2**

**Electronic  
Fundamentals**

3/2 - C	Components
3/2 - C - AC	Active Components
3/2 - C - AC - VR	Voltage Regulators



<b>3/2 - C</b>	<b>Components</b>
<b>3/2 - C - PC</b>	<b>Passive Components</b>
<b>3/2 - C - PC - A</b>	<b>An Introduction</b>

## **3/2 - C - PC**

### **Passive Components**

---

## **3/2 - C - PC - A**

### **An Introduction**

---

Some separate the types of components into passive and active. Among the passive components are resistors, capacitors, inductors and transformers. Among the active components are diodes, transistors, integrated circuits (ICs), thyristors, triacs, LEDs (light emitting diodes), voltage regulators, OPs (operational amplifiers), timers, logic gates, and CPUs (central processing units, sometimes called microprocessors).

The major difference is that passive components cannot themselves generate voltage or current, nor can they provide amplification (gain). They “condition” the voltage and current produced by other (active) components. This includes attenuation, waveshaping, and storing. Active components can generate voltage and/or current, or can amplify it.

Understanding what the individual components do, how they do it, and how they interact, goes a long way in understanding troubleshooting and repair.

**3/2**  
Electronic  
Fundamentals

3/2 - C	Components
3/2 - C - PC	Passive Components
3/2 - C - PC - A	An Introduction

# 3/2

Electronic  
Fundamentals

3/2 - C	Components
3/2 - C - PC	Passive Components
3/2 - C - PC - C	Capacitors

## 3/2 - C - PC

### Passive Components

### 3/2 - C - PC - C

#### Capacitors

#### Basic Function

The workings of a capacitor cause problems for some who are new to electronics. The schematic symbol shows a break in the circuit, which is very much what the capacitor is (for DC, anyway).

Their primary purpose is to store energy. Capacitors do this by holding an electrical field in the dielectric between their plates. This ability makes them useful in a variety of ways.

They can hold the charge, sometimes for extended periods of time. This makes them suitable as a reservoir. Some devices now use a capacitor to hold the memory of a device in case there is a temporary power outage. This works in much the same way as a battery backup.

#### Current

By allowing the capacitor to fill and then drain off the charge at a regular rate, the current flowing through the capacitor is smoothed. This function is used in power supplies to filter the incoming AC into the needed DC.

Because they allow passage of AC while being open to DC, they are also used as AC couplers between amplifier stages, and as decouplers to help eliminate AC noise in a DC circuit. (For the latter case, a capacitor placed between the circuit and ground shunts, or decouples, any AC while having no effect on the DC.)

#### Rating

Capacitors are rated in Farads. This is a very large unit of measurement beyond the limits of actual capacitance devices. Consequently, capacitors are rated in tiny fractions of a Farad. The most common are  $\mu\text{F}$  (micro, or one one-millionth) and pF (pico, or one one-billionth).

#### Characteristics

1. The actual value depends on how the capacitor is manufactured. Among the considerations are overall physical size, effective surface area of the plate(s), thickness of the dielectric, the dielectric constant and the capacitor's function.

3/2 - C	Components
3/2 - C - PC	Passive Components
3/2 - C - PC - C	Capacitors

- The working voltage is important. This is the maximum voltage that can be applied continuously under the operating conditions. Exceeding this rating can cause serious trouble, including fire and even explosion.
- The tolerance rating may be as high as 20% or as low as 2%. (Capacitors with greater accuracy are rare.)
- The temperature range at which the capacitor functions is the temperature coefficient.
- The stability of the capacitor, across its operational range and across time, can help determine which component is needed.
- The maximum leakage current which flows in the dielectric of the capacitor concerns the flow of DC through the capacitor. Ideally this will be zero. (The capacitor should be open to DC current,) with the DC resistance between the plates being infinite. In reality, there is always some leakage.

### Replacement

As is the case with resistors, replacement capacitors must match the original. It can be an improvement on it in some ways. You can replace a capacitor rated to handle 15 V with one designed to handle 25 V, but not the other way around. Likewise, you can replace a capacitor of a 20% tolerance with one of 10% tolerance.

This kind of upgrading is not only allowable but is sometimes preferable. It's possible that the manufacturer installed a lower rated capacitor to save money. The circuit will operate, but could fail more often or more easily. By installing upgraded capacitors you improve the margin under which they operate.

This is not always possible. Capacitors with higher ratings as far as working voltage, tolerance and stability are sometimes physically larger and won't fit. Another area you can exceed is the component's rated operating temperature. As the temperature increases, the capacitor's working voltage level decreases. The rule of thumb is that the actual working voltage should be no greater than about 50-60% of the rated working voltage.

### Frequency

The frequency in the circuit is also important. Most capacitors have no difficulty as long as the frequency is below 100 kHz. Above this, there may be increased losses across the dielectric, increased heating, and a loss of stability. Yet another consideration involves capacitors used as filters in power supplies. These are rated for ripple current. The typical ripple current rating for a large filter capacitor is in the 2-8 A range.

**3/2**  
Electronic  
Fundamentals

3/2 - C	Components
3/2 - C - PC	Passive Components
3/2 - C - PC - C	Capacitors

**Table 1**  
**Capacitor**  
**Characteristics**

Capacitor type	Ceramic	Electrolytic	Metallised film	Poly-carbonate	Poly-styrene	Tantalum	Mica	Polyester	Poly-propylene
Capacitance range (F)	2.2p to 100n	100n to 68m	1u to 16u	10n to 10u	10p to 10n	100n to 100u	2.2p to 10n	10n to 2.2u	1n to 470n
Typical tolerance (%)	±10 and ±20	-10 to +50	±20	±20	±2.5	±20	±1	±20	±20
Typical voltage rating (d.c.)	50 V to 250 V	6.3 V to 400 V	200 V to 600 V	63 V to 630 V	160 V	6.3 V to 35 V	350 V	250 V	1 kV
Temperature coefficient (ppm/°C)	+100 to -4700	+1000 typical	+100 to +200	+60	-150 to +80	+100 to +250	+50	+200	-200
Stability	Fair	Poor	Fair	Excellent	Good	Fair	Excellent	Good	Good
Ambient temperature range (°C)	-85 to +85	-40 to +85	-25 to +85	-55 to +100	-40 to +70	-55 to +85	-40 to +85	-40 to +100	-55 to +100
Typical applications	Decoupling, temperature compensation	Decoupling, reservoir and smoothing circuits in power supplies	High voltage power supplies	Filters, oscillators, timing	General purpose, timing and decoupling	General purpose, timing and decoupling	Tuned circuits, filters, oscillators	General purpose	High-voltage a.c. circuits

# 3/2

Electronic  
Fundamentals

3/2 - C	Components
3/2 - C - PC	Passive Components
3/2 - C - PC - C	Capacitors

On these same capacitors there is often a bleeder resistor. These capacitors tend to store charges for long periods. The bleeder resistor drains this charge when the power supply is turned off. Its size and power rating are determined by the voltage drop and the current.

There are many types of capacitors. Among them are ceramic, air, plastic film, tantalum and electrolytic. An exact match in replacement is almost invariably required.

Of special note here is that some capacitors (such as electrolytic) have polarity. When the capacitor is polarized it is critical to install it with the correct polarity. Failure to do so causes overheating at the very least. It is not uncommon for the capacitor to explode under this circumstance. Either way, damage to other components in the circuit is almost assured.

## Color Coding

Many capacitors have their values stamped or printed on the casing. Some may use a color coding. This coding on capacitors is in the same order as the code for resistors.

The major difference is that capacitors sometimes use dots of color rather than bands. This is particularly true if the capacitor is of the rectangular mica or button type.

The color scheme and order are the same.

**Table 2**  
Color Code for  
Ceramic Capacitors

Color	Figure	Multiplier	Tolerance (%)
Black	0	1	± 20
Brown	1	10	-
Red	2	100	-
Orange	3	1000	-
Yellow	4	10,000	-
Green	5	-	-
Blue	6	-	-
Violet	7	-	-
Gray	8	0.01	-
White	9	0.1	± 10

The EIA standard is shown in Figure 1. The first significant digit is at the top left, with the coding proceeding in a clockwise direction. A mica capacitor so coded, with dots of red, orange and black on the top row, and brown, gold and blue on the bottom, would have 2, 3 and 0 as the significant digits, a multiplier of 10, making the capacitor a 2300 pF value. The gold spot shows that the capacitor has a tolerance of 5% and the blue dot signifies a voltage rating of 600 V.

**3/2**  
Electronic  
Fundamentals

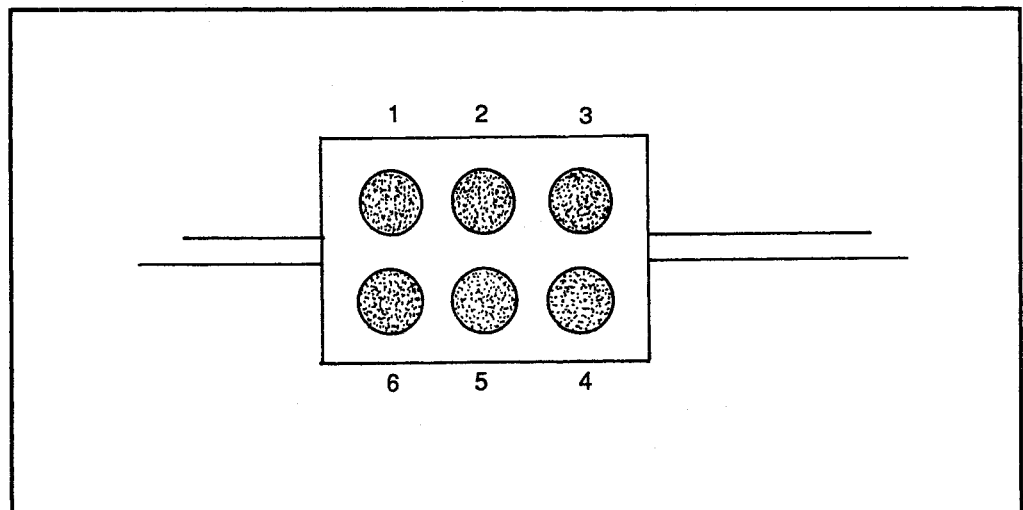
3/2 - C	Components
3/2 - C - PC	Passive Components
3/2 - C - PC - C	Capacitors

**Table 3**  
Color Codes for  
Plastic film  
Capacitors

Color Bands			Capacity (in $\mu\text{F}$ )
Brown	Black	Orange	0.01
Brown	Green	Orange	0.015
Red	Red	Orange	0.022
Orange	Orange	Orange	0.033
Yellow	Violet	Orange	0.047
Blue	Gray	Orange	0.065
Brown	Black	Yellow	0.1
Brown	Green	Yellow	0.15
Red	Red	Yellow	0.22
Orange	Orange	Yellow	0.33
Yellow	Violet	Yellow	0.47
Blue	Gray	Yellow	0.68
Brown	Black	Green	1.00
Brown	Green	Green	1.5
Red	Red	Green	2.2

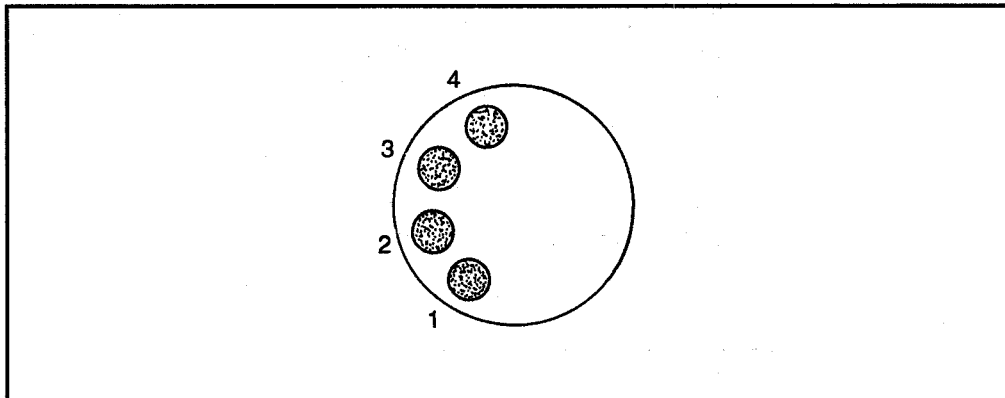
**Table 4**  
Color Codes for  
Tantalum  
Capacitors

Color	Top	Band	Spot	Voltage
Brown	1	1	10	-
Red	2	2	100	-
Orange	3	3	-	-
Yellow	4	4	-	6.3
Green	5	5	-	16
Blue	6	6	-	20
Violet	7	7	-	20
Gray	8	8	0.01	25
White	9	9	0.1	3
Black	-	0	1	10
Pink	-	-	-	35



**Figure 1:** Color coding on a rectangular mica capacitor

3/2 - C	Components
3/2 - C - PC	Passive Components
3/2 - C - PC - C	Capacitors



**Figure 2:** Color coding on button-type capacitor

Note that some surplus mica capacitors use a different coding. These are the AWS (Army War Standards) and JAN (Joint Army-Navy) standards. If this scheme is used, the first dot in the top row will be black or silver. In this case, the first significant digit will be the second dot—the second significant digit will be the third and the bottom row will remain as with the EIA standard.

Figure 2 shows the circular coding on button capacitors. The direction is clockwise. Again, the first dot is the first significant digit; the second is the second significant digit; the third is the multiplier; the last is the tolerance.

**Variable Capacitors** As with variable resistors, variable capacitors can be adjusted. With rare exception, this is done by means of a knob on a shaft that protrudes through the cabinet of the device (or by some similar arrangement).

The basic construction consists of plates separated by a dielectric, just as with a fixed capacitor, but with the variable capacitor, the plates are mounted to a shaft so that one set of plates can be moved. The effect is to increase or decrease the surface area which in turn changes the capacitance. The stationary plates are the stator plates (often called, simply, the stator). The moving plates are the rotor plates (or rotor).

The dielectric may be a gas or a solid. The former tends to be large and heavy. Because of this, and because improvements have been made in solid dielectrics, you'll find fewer and fewer air capacitors except in devices that use large amounts of energy, such as higher power transmitters.

The design of the variable capacitor is similar to the design of a fixed capacitor.



# 3/2

Electronic  
Fundamentals

3/2 - C	Components
3/2 - C - PC	Passive Components
3/2 - C - PC - C	Capacitors

The dielectric, being an insulator, doesn't conduct electricity. It can, however, reach a bursting point. If this happens, an electrical charge will jump the gap between the plates. If the dielectric is solid, a hole may be burned through it, causing permanent damage to the component.

One of the most common uses of the variable capacitor is in tuning circuits, such as receivers and transmitters.

**Table 5**

Variable/preset preset capacitor type	Air spaced	Ceramic	Plastic film
<b>Capacitance range (pF)</b>	5 to 500	2 to 200	10 to 750
<b>Typical tolerance (%)</b>	±10	±20	±10
<b>Typical voltage rating (DC)</b>	250 V to 1 kV	63 V	63 V to 150 V
<b>Stability</b>	Excellent	Fair	Good
<b>Typical applications</b>	Transmitters, RF signal generators	Compensation, oscillator trimming	Radio tuning, oscillator trimming

Section 3 • Electronic Repair Basics

**3/2**  
Electronic  
Fundamentals

3/2 - C	Components
3/2 - C - PC	Passive Components
3/2 - C - PC - C	Capacitors

3/2 - C	Components
3/2 - C - PC	Passive Components
3/2 - C - PC - I	Inductors

## 3/2 - C - PC

### Passive Components

## 3/2 - C - PC - I

### Inductors

#### Basic Function

You will often hear of inductors called “coils”. This describes their physical structure very well. Their basic function is to store energy in the form of a magnetic field. They can be used as filters, chokes and, in one sense, as part of a transformer. They are measured in a unit called a Henry. Since this is a fairly large unit, most inductors are rated in milli-, micro- or pico-henries. The actual value is determined by the size of the inductor, the size of the wire used, the number of turns of wire and the core of the component.

The inductor may have a hollow core, or a core made of iron or ferrite. The latter tends to increase the capacity of the inductor but has the disadvantage of current flow increases and inductance decreases. It's possible that the magnetic flux in the core will become so saturated that the inductor will fail.

The maximum current is a critical factor. As stated above, if the current exceeds

**Table 1**

Inductor-type	Single-layer open		Multi-layer open		Multi-layer pot cored	Multi-layer iron cored
	Air	Ferrite	Air	Ferrite		
Core material	Air	Ferrite	Air	Ferrite	Ferrite	Iron
Inductance range (H)	50 n to 10 $\mu$	1 $\mu$ to 100 $\mu$	5 $\mu$ to 500 $\mu$	10 $\mu$ to 1 m	1 m to 100 m	20 m to 20 H
Typical d.c. resistance ( $\Omega$ )	0.05 to 1	0.1 to 10	1 to 20 20	2 to 100 100	2 to 100	10 to 400
Typical tolerance (%)	$\pm 10$	$\pm 10$	$\pm 10$	$\pm 10$	$\pm 10$	$\pm 10$
Typical Q-factor	60	80	100	80	40	20
Typical current rating (A)	0.1	0.1	0.2	0.5	0.5	0.1
Typical frequency range (Hz)	5 M to 500 M	1 M to 200 M	200 k to 20 M	100 k to 10 M	1 k to 1 M	50 to 100 k
Typical applications	Tuned circuits		Filters and HF transformers		LF and MF filters and transformers	Smoothing chokes and LF filters

**3/2****Electronic  
Fundamentals**

3/2 - C

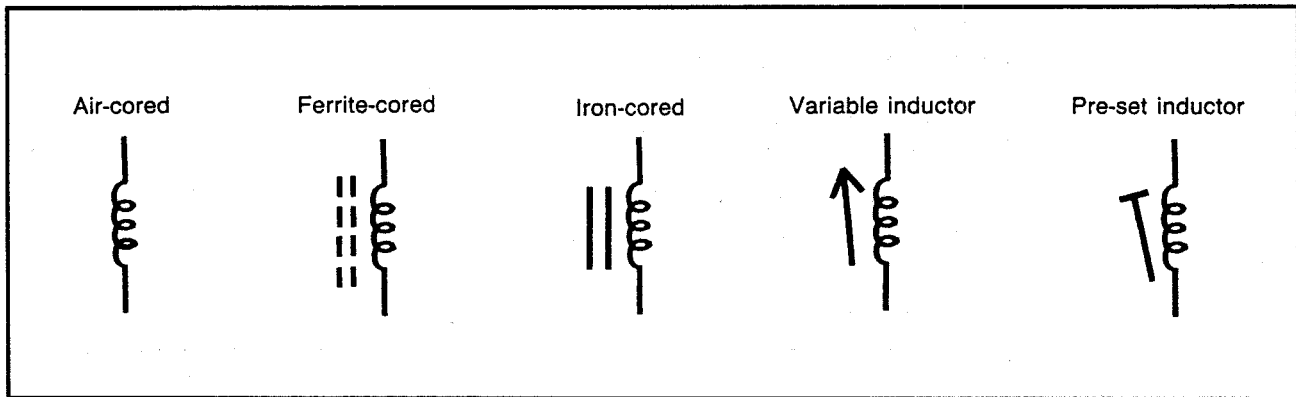
Components

3/2 - C - PC

Passive Components

3/2 - C - PC - I

Inductors

**Figure 1:** Inductor symbols

the designed allowance, the inductance can decrease. Moreover, the inductor is likely to overheat. If enough current flows, the wires of the inductor will melt the insulation, short, overheat more and possibly melt the wires themselves. As with other components, inductors are rated for accuracy (tolerance), temperature coefficient, overall stability, frequency range, DC resistance, and Q-factor (quality factor).

When replacing a failed inductor for which an identical replacement part is unavailable, it is often possible to use a component selected from the range of fixed RF inductors available from several manufacturers. These components are available in the standard range of preferred values between 1  $\mu\text{H}$  to 10 mH.

In many applications the inductance value should be adjustable to allow precise tuning of the arrangement (e.g. when the inductor is required to form a part of a resonant circuit in conjunction with a fixed series or parallel connected capacitor). In such cases an adjustable inductor is required. Here again, components are available from several manufacturers.

When an exact or a near equivalent is unavailable, the repairer must wind a replacement inductor or make use of a component salvaged from a similar item of equipment.

For those who may wish to tackle this option, the following formulas should assist with the coil winding:

(a) Single-layer coils (length:diameter ratio greater than 5:1)

$$L = \frac{0.2 N^2 d^2}{20l + 9d}$$

3/2 - C	Components
3/2 - C - PC	Passive Components
3/2 - C - PC - I	Inductors

and

$$N = \frac{2.24}{d} \sqrt{L(20l + 9d)}$$

where L is the inductance value (in  $\mu\text{H}$ ), N is the number of turns, d is the diameter of the former (in cm) and l is the length of the coil winding (in cm).

(b) Multi-layer coils (length:diameter ratio less than 1:1)

$$L = \frac{N^2 d_m^2}{100 d}$$

and

$$N = \frac{10}{d_m} \sqrt{Ld}$$

where L is the inductance value (in  $\mu\text{H}$ ), N is the number of turns,  $d_m$  is the mean diameter of the winding (in cm) and d is the depth of the winding (in cm).

As an example, assume that a single-layer fixed inductor of 100  $\mu\text{H}$  is to be replaced and that a former of diameter 0.8 cm and a length of 5 cm is available to be used. The number of turns required are given by the following formulas:

$$N = \frac{2.24}{d} \sqrt{L(20l + 9d)}$$

where  $d = 0.8$  cm,  $l = 5$  cm, and  $L = 100$   $\mu\text{H}$ . Thus:

$$N = \frac{2.24}{0.8} \sqrt{100 [(20 \times 5) + (9 \times 0.8)]}$$

giving:

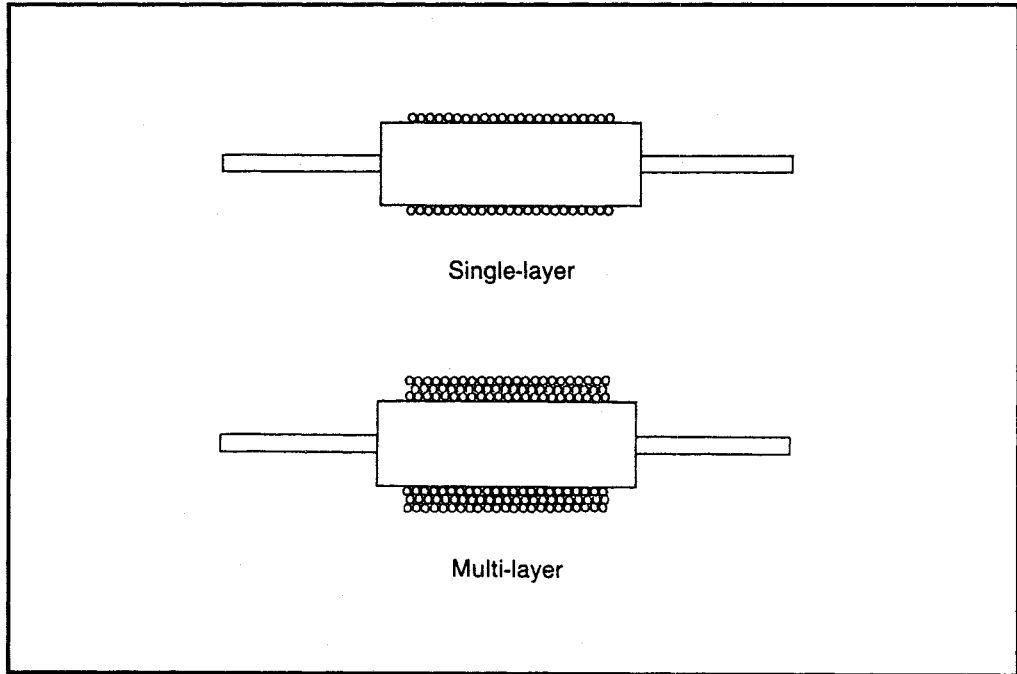
$$N = 2.8 \sqrt{100 (100 + 7.2)}$$

or

$$\begin{aligned} N &= 2.8 \sqrt{100 \times 107.2} \\ &= 2.8 \sqrt{10720} = 2.8 \times 103.5 \end{aligned}$$

giving an end result that  $N = 290$  turns.

3/2 - C	Components
3/2 - C - PC	Passive Components
3/2 - C - PC - I	Inductors



**Figure 2:** Single and multilayer inductors

It is important to note that where an inductor is adjustable and fitted with a ferrite core, the value of inductance is increased by a factor of between 1.5 and 3, depending on the grade of ferrite and its position. If it is essential to obtain an exact value of inductance, it is advisable to reduce the number of turns (by approximately 30%) and fit an adjustable ferrite dust core.

Where it is necessary to rewind a ferrite pot core, the following formula may be used to determine the number of turns necessary to achieve a particular inductance value.

$$L = N^2 A_L \text{ and } N = \sqrt{\frac{L}{A_L}}$$

where  $N$  = number of turns,  $L$  = inductance value in  $nH$ ,  $A_L$  = inductance factor in  $nH/n^2$ .

Note that it is necessary to take into account the number of turns of wire which can be accommodated on the bobbin, bearing in mind that the resistance of the winding increases as the diameter of the wire decreases. To avoid appreciable temperature rise due to  $I^2R$  losses within the winding wires, winding wires of 0.2

3/2 - C	Components
3/2 - C - PC	Passive Components
3/2 - C - PC - I	Inductors

mm, 0.5 mm and 1 mm diameter should be only used for rms currents not exceeding 100 mA, 750 mA and 4 A, respectively.

As an example, assume that a 1 mH ferrite-pot-cored inductor is to be rewound. If the component is to operate in a circuit in which the rms current is 500 mA at a frequency of 3.5 kHz, the following steps illustrate the design method:

- (i) Select an appropriate wire diameter which will safely carry a current of 500 mA rms. A diameter of 0.5 mm is adequate in this application.
- (ii) Determine the number of turns required using the formula:

$$N = \sqrt{\frac{L}{A_L}}$$

where  $L = 1 \text{ mH} (=1,000,000 \text{ nH})$  and  $A_L = 250$  (for the ferrite core):

$$N = \sqrt{\frac{1,000,000}{250}} = 63 \text{ turns}$$

- (iii) Check that the required number of turns (63) of 0.5 mm diameter wire can be accommodated on the bobbin.

Inductance values of iron-cored inductors are very much dependent on the applied direct current (inductance falls as the value of applied direct current increases). Further, the stray magnetic field generated by a transformer or inductor (particular an open type) pervades the space which surrounds it.

Problems can sometimes arise when a replacement inductor has to be mounted differently from an original component. In the case of RF applications and for chokes which are used in power supply filter circuits, it is generally necessary to position inductors in a way that minimizes inductive coupling.

Replacement inductors should follow the same orientation and be screened in a similar manner to the components which they replace. In particular, it is essential to ensure that the metal laminations of an iron-cored inductor are properly grounded via the case and clamping screws. Failure to observe this precaution can result in a high level of radiated noise (particularly with high-current, switching and power control apparatus).

**3/2**

**Electronic  
Fundamentals**

3/2 - C	Components
3/2 - C - PC	Passive Components
3/2 - C - PC - I	Inductors



# 3/2

Electronic  
Fundamentals

3/2 - C	Components
3/2 - C - PC	Passive Components
3/2 - C - PC - R	Resistors

## 3/2 - C - PC

### Passive Components

## 3/2 - C - PC - R

### Resistors

#### Basic Function

Resistors “resist” the flow of voltage and current. In this way they allow the control of both. For example, the voltage drop across a resistor (see Ohm’s Law Section “3/2 - O”) can be used to provide the proper bias potentials for driving transistor or IC amplifiers. The resistor can also be used to attenuate (reduce). One extreme example of this is the bleeder resistor which absorbs and dissipates energy.

The value of a resistor is measured in ohms ( $\Omega$ ). Since the values needed are often very high, resistors are often rated in  $K\Omega$  or  $M\Omega$  (thousands and millions, respectively). This and other electrical characteristics are determined by the materials from which the resistor is made.

#### Value

As stated above, this is expressed in  $\Omega$ ,  $K\Omega$  or  $M\Omega$ .

#### Power Rating

This is the amount of power, in watts, that the resistor can dissipate safely. In most circuits this value is very small. 1/4 watt and lower is fairly normal. However, there are times when the power dissipation must be higher. This is usually accomplished by making the resistor physically larger, and often with a covering that helps dissipate the heat.

#### Accuracy

The accuracy (tolerance) of a resistor can be anything from about 20% (rare) to less than 1%. The most common are accurate within 5% of the rated value.

#### Temperature

The temperature coefficient gives you an indication of how the resistor performs as the temperature changes. Usually this is relatively unimportant, but it could be critical if the device is operated under temperature extremes, or if the resistor is expected to dissipate heat.

#### Stability

Other conditions can also affect the way the resistor performs. Its stability under the operating range isn’t usually critical, but as with the temperature coefficient, it may be unstable under certain conditions.

#### Noise

Dissipation of energy always causes some noise. With rare exception, this doesn’t matter and won’t affect the operation or the rest of the circuit.

# 3/2

Electronic  
Fundamentals

3/2 - C	Components
3/2 - C - PC	Passive Components
3/2 - C - PC - R	Resistors

## Replacement

When replacing resistors, be sure that the replacement is at least as good as the original. It can have better ratings, but not worse ones. For example, if the resistor being replaced had a 5% tolerance, you can use one with a 1% tolerance, but not one with a 10% tolerance.

Either way, the K value must be identical. A 110 K resistor is not an upgrade to a 100K resistor—it is simply a mismatch. In this case it's close enough that it might work. It might also cause the unit to act erratically, or cause damage.

If that 100 K resistor has a tolerance of 10%, it could have an actual value of anything from 90 K to 110 K. At first, you might think that you could put a 110 K resistor in its place. However, if that 110 K resistor also has a 10% tolerance, its actual value could be anything from 99 K to 121 K. (Using one rated at a 5% tolerance doesn't help much. This would mean that its upper end would be 115.5 K and closer to the need value, but its lower end would be 104.5 K.)

Also note that this shows that if the original resistor is of tighter tolerance, the importance of an exact match becomes more critical. In the example above you might (or might not) get away with putting a 110 K resistor in the place of a 100 K if that 100 K resistor is rated at 10%. If it has a 5% tolerance, using the

Table 1

Resistor type	Carbon composition	Carbon film	Metal film	Metal oxide	Ceramic wire-wound	Vitreous enamel wire-wound	Aluminium clad wire-wound
Resistance range $\Omega$	2.2 to 1 M	10 to 10 M	1 to 1 M	10 to 1 M	0.47 to 22 k	0.1 to 22 k	0.1 to 1 k
Typical tolerance	$\pm 10$	$\pm 5$	$\pm 1$	$\pm 2$	$\pm 5$	$\pm 5$	$\pm 5$
Power rating (W)	0.125 to 1	0.25 to 2	0.125 to 0.5	0.25 to 0.5	4 to 17	2 to 4	25 to 50
Temperature coefficient (ppm/ $^{\circ}\text{C}$ )	+1200	-250	+50 to 100	+250	$\pm 250$	$\pm 75$	$\pm 50$
Stability	Poor	Fair	Excellent	Excellent	Good	Good	Good
Noise performance	Poor	Fair	Excellent	Excellent	n/a	n/a	n/a
Ambient temperature range to ( $^{\circ}\text{C}$ )	-40 to +105	-45 to +125	-55 to +125	-55 to +155	-55 to +200	-55 to +200	-55 to +200
Typical applications	Power supplies and large-signal amplifiers	General purpose	Small-signal amplifiers, test and measuring equipment		Power supplies and large-signal amplifiers	General purpose power dissipation	

**3/2**  
Electronic  
Fundamentals

3/2 - C	Components
3/2 - C - PC	Passive Components
3/2 - C - PC - R	Resistors

110 K as a replacement would be risky. It would be a mismatch. And if the original has a 1% tolerance, the 110 K resistor in the example above is out of the question. (If you see a 1% tolerance resistor, there is almost certainly a very good reason for it.)

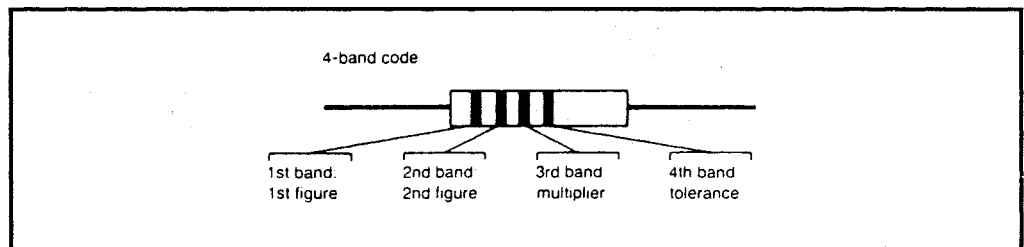
The physical size of the resistor could also be a factor. 1/4 watt resistors are common in part because they are less expensive than those with a higher power rating. They are also physically smaller. A 10-watt resistor is considerably larger.

There are times when a larger resistor can be used, but much of the time the larger resistor simply won't fit correctly.

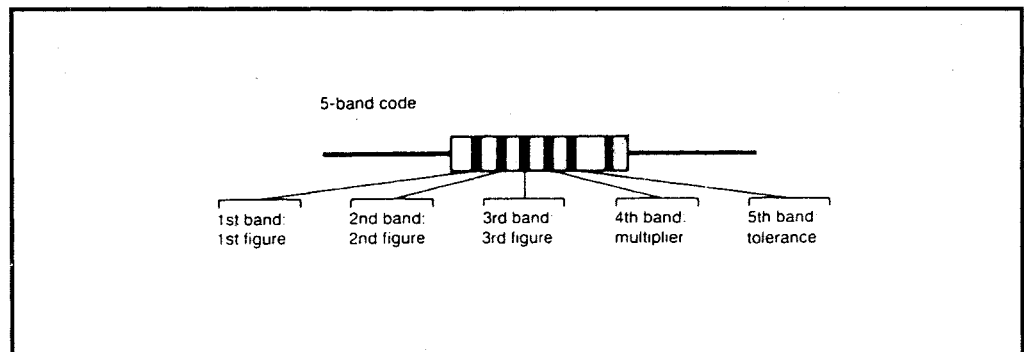
**Color Codes**

Carbon and metal oxide resistors are marked with color codes to tell you the value and tolerance of the component. There can be as many as six of these bands. (Note that the code shown in Table 1 is also used for other components that are color coded.)

Figure 1 shows a four-band resistor. The first band is the 1st significant figure; the second is the 2nd significant figure; the third is the multiplier; and the fourth is the tolerance rating.



**Figure 1: Coding of four-band resistors**



**Figure 2: Coding of five-band resistors**

# 3/2

Electronic  
Fundamentals

3/2 - C	Components
3/2 - C - PC	Passive Components
3/2 - C - PC - R	Resistors

**Table 2**  
**Resistor Color**  
**Codes**

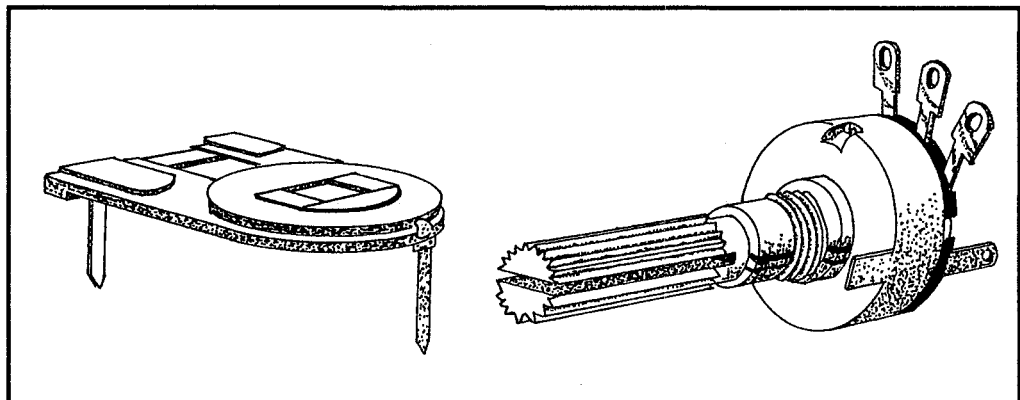
Color	Figure	Multiplier	Tolerance (%)	
Silver	-	0.01	Ω	10
Gold	-	0.1	Ω	5
Black	0	1	Ω	-
Brown	1	10	Ω	1
Red	2	100	Ω	2
Orange	3	1	KΩ	-
Yellow	4	10	KΩ	-
Green	5	100	KΩ	0.5
Blue	6	1	MΩ	0.25
Violet	7	10	MΩ	0.1
Gray	8	100	MΩ	-
White	9	-	-	-

For example, if the bands are brown, black, red and silver, the significant numbers are 1 and 0. The multiplier is 2. This means that the value of the resistor is 1000 Ω (10 x 100). The silver band signifies a tolerance of 10%.

If a resistor is coded orange, yellow and orange, with no fourth band, its value is 34,000 Ω and it has a tolerance rating of 20% (rare these days).

If the resistor has five bands (Figure 2), read it the same except that the third band is the 3rd significant digit, which makes the fourth band the multiplier and the fifth band the tolerance rating.

In this case, envision a five-band resistor that is marked blue, green, yellow, orange and gold. The significant numbers are then 6, 4 and 3, with the multiplier being 3. This shows the value to be 643,000 Ω (643 KΩ). The gold band signifies a 5% tolerance.



**Figure 3:** Two common types of variable resistors

# 3/2

Electronic  
Fundamentals

3/2 - C	Components
3/2 - C - PC	Passive Components
3/2 - C - PC - R	Resistors

Occasionally, you may see a resistor with a silver or black band at the very end of the resistor and ahead of the color coding. If seen, this simply means that the resistor is of either industrial or military specifications.

**Variable Resistors** Also called potentiometers (pots for short), variable resistors can be adjusted across a range of resistances. Some have shafts to accept knobs, others merely have a slot through which you can insert a screwdriver to make the adjustment.

Table 3

	Variable resistor type			
	Carbon track	Cermet	Wire-wound	Multiturn wirewound
<b>Resistance range (<math>\Omega</math>)</b>	5 k to 1 M	10 to 1 M	10 to 100 k	100 to 100 k
<b>Typical tolerance (%)</b>	$\pm 20$	$\pm 10$	$\pm 5$	$\pm 5$
<b>Power rating (W)</b>	0.25	1 to 5	1 to 3	1.5 to 3
<b>Temperature coefficient (ppm/<math>^{\circ}</math>C)</b>	-500 typical	$\pm 150$	+50 typical	+50 typical
<b>Stability</b>	Poor	Good	Good	Good
<b>Noise performance</b>	Poor	Good	Good	Good
<b>Ambient temperature range (<math>^{\circ}</math>C)</b>	-10 to +70	-40 to +85	-20 to +100	-55 to +125
<b>Typical applications</b>	General purpose	Power supplies, test and measuring equipment		Test and measuring equipment

Section 3 • Electronic Repair Basics

**3/2**  
Electronic  
Fundamentals

3/2 - C	Components
3/2 - C - PC	Passive Components
3/2 - C - PC - R	Resistors

# 3/2

Electronic  
Fundamentals

3/2 - C	Components
3/2 - C - PC	Passive Components
3/2 - C - PC - T	Transformers

## 3/2 - C - PC

### Passive Components

## 3/2 - C - PC - T

### Transformers

#### Basic Function

Transformers are used for coupling and/or changing alternating currents from one circuit to another. The two circuits are coupled together by mutual inductance; the input (primary) and output (secondary) windings comprise inductors wound on a common core. The transformation which occurs relates to the ability of a transformer to step-up or step-down the voltage present at the primary (input). Voltage is said to be stepped-up when the secondary voltage is greater than the primary voltage, and stepped-down when the secondary voltage is less than the primary voltage.

Unlike an amplifier, a transformer provides no inherent power gain. The power at the secondary winding will, in fact, be slightly less than at the primary due to losses within the transformer. It is important to note that an increase in secondary voltage can only be achieved at the expense of a corresponding reduction in the secondary current and vice versa. (By using the power formula  $P=IE$  you can discover and explore this for yourself.)

Typical applications for transformers include stepping-up or stepping-down voltages in power supplies, coupling signals in AF amplifiers, matching impedance and DC isolation.

The electrical characteristics of a transformer are determined by a number of factors including the core material and physical dimensions. Parameters to consider when selecting a transformer for a particular application include:

#### Characteristics

1. The rated primary and secondary voltages and currents (a turns ratio or a voltage ratio may also be specified).
2. The power rating of the transformer. This is the maximum power, expressed in volt-amperes (VA) which can be continuously delivered by the transformer under a given set of conditions.

**3/2**  
Electronic  
Fundamentals

3/2 - C	Components
3/2 - C - PC	Passive Components
3/2 - C - PC - T	Transformers

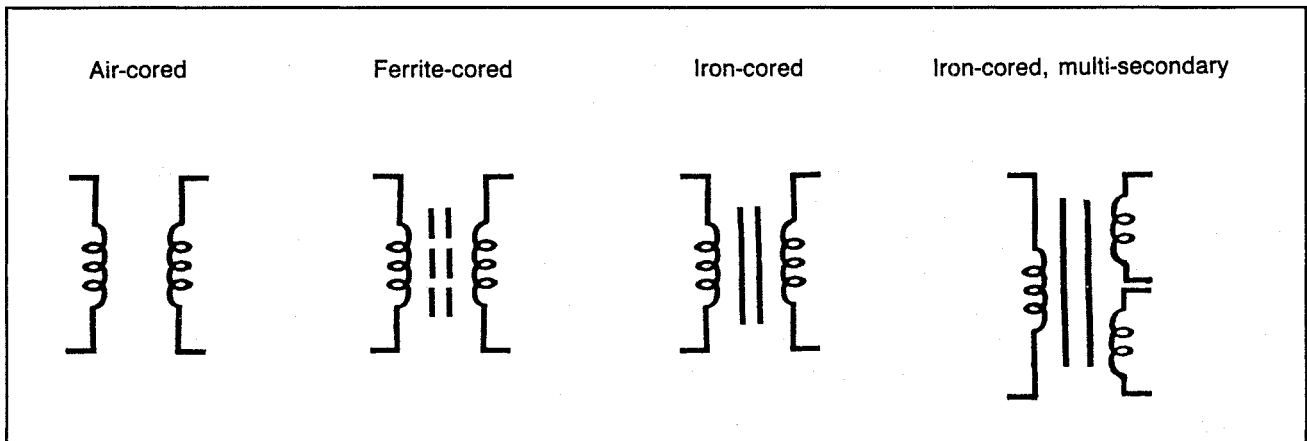
It is important to note that loading a transformer beyond its ratings can have dire consequences. The component may overheat, cause irreversible damage to the insulation between the adjacent turns and/or eventual fusing of the windings.

3. The frequency range of the component. Most power transformers operate happily at either 50 Hz or 60 Hz.
4. The regulation of a transformer. This is usually expressed as a percentage of full-load. The specification is a measure of the ability of a transformer to maintain its rated output voltage under load.

The following table summarizes the properties of commonly available transformers:

**Table 1**

Transformer type	Ferrite cored	Iron cored	Iron cored
Typical power rating	n/a	10m W to 10 W	3 VA to 500 VA
Typical regulation (%)	n/a	n/a	5 to 15
Typical frequency range (Hz)	1 k to 100 k	50 to 20 k	45 to 400
Typical applications	Pulse applications	AF amplifiers	Power supplies
n/a = not normally applicable to transformers of this type			



**Figure 1:** Transformer symbols

Several manufacturers can supply a range of replacement transformers with various ratings. Replacement transformers can also be manufactured on a one-off basis (though this can be expensive—it is well worth shopping around for a stock item before resorting to this course of action). Alternatively, transformers



**3/2**  
Electronic  
Fundamentals

3/2 - C	Components
3/2 - C - PC	Passive Components
3/2 - C - PC - T	Transformers

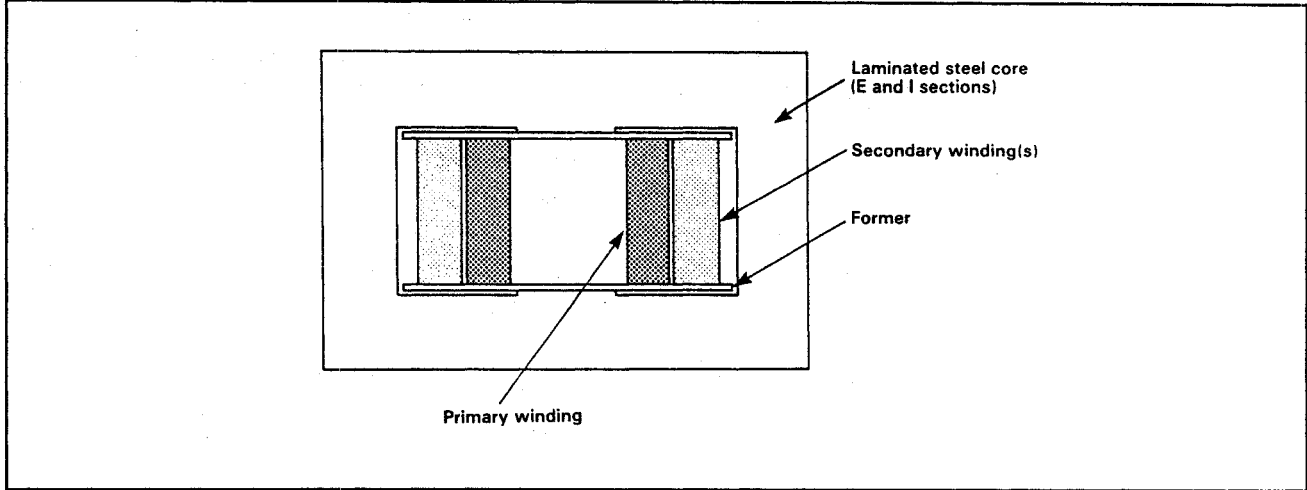


Figure 2: Transformer construction

can be constructed from proprietary kits. These are available in a variety of sizes (including 20 VA, 50 VA, 100 VA and 200 VA) and usually come with a double-section core (usually with the primary pre-wound), insulating shrouds, laminations and end-mounting frames.

**Formulas**

The following formulas are useful when constructing replacement low-frequency transformers which use laminated steel or toroidal cores:

(a) Turns ratio and voltage ratio

$$\frac{N_p}{N_s} = \frac{V_p}{V_s}$$

(b) Turns ratio and current ratio

$$\frac{N_p}{N_s} = \frac{I_s}{I_p}$$

(c) Current ratio and voltage ratio

$$\frac{I_p}{I_s} = \frac{V_s}{V_p}$$

where  $N_p$  and  $N_s$  are the number of primary and secondary turns respectively,  $V_p$  and  $V_s$  are the primary and secondary voltage respectively, and  $I_s$  and  $I_p$  are the primary and secondary current.

3/2 - C	Components
3/2 - C - PC	Passive Components
3/2 - C - PC - T	Transformers

When replacing a transformer with a unit that is different from the original, it is essential that the power rating (in VA) for the replacement is adequate. The working VA for a power transformer can be estimated by calculating the total power consumed by each secondary load and multiplying it by 1.1 (to allow for losses within the transformer when on load).

For a transformer with a single secondary winding:

$$\begin{aligned} \text{Secondary (load power) } P_L &= L_s \times V_s \\ \text{Primary (input power) } P_{IN} &= 1.1 \times P_L \end{aligned}$$

Where several secondary windings are present, it is necessary to determine the load power for each secondary and then add these together to find the total load ( $P_L$ ). The primary (input) power can then be estimated by using the previous formula.

As an example, consider the case of a transformer having three secondary windings. Two windings are rated at 15 V and each supplies rms current of 2 A, while the third secondary is rated at 6.3 V and provides an rms current of 4 A.

The total secondary power is given by:

$$P_L = (15 \text{ V} \times 2 \text{ A}) + (15 \text{ V} \times 2 \text{ A}) + (6.3 \text{ V} \times 4 \text{ A})$$

thus,  $P_L = 30 + 30 + 25.2 = 85.2 \text{ VA}$

The estimated input power ( $P_{IN}$ ) is given by:

$$P_{IN} = 1.1 \times P_L = 1.1 \times 85.2 = 93.7 \text{ VA}$$

A replacement transformer rated at 100 VA would be satisfactory.

In any event, it is important to note that maximum power ratings for transformers are related to operating temperatures and should be derated when high ambient temperatures are expected. Further, in order to maintain high efficiency, it is important to avoid saturation within the core of a transformer. Where reliability and efficiency is important, transformers should be operated at well within their nominal VA rating.

The stray magnetic field generated by a transformer pervades the space which surrounds it. The field around a power transformer may be appreciable and, to avoid stray coupling of signals and hummings, it is best to exercise care when positioning a transformer. For this reason, power transformers should never be

**3/2**  
Electronic  
Fundamentals

3/2 - C	Components
3/2 - C - PC	Passive Components
3/2 - C - PC - T	Transformers

mounted closely to the early stages of an audio amplifier nor should they be placed adjacent to audio frequency transformers or cathode ray tubes.

As with inductors, it is important to ensure that the metal laminations of an iron-cored inductor are properly grounded, via the case and clamping screws. Failure to observe this precaution can result in a high level of radiated noise, particularly with high-current, switching and power control apparatus. Improperly grounding the transformer can also bring a potential safety hazard.

Finally, when replacing toroidal transformers, care must be taken to ensure that the ends of the fixing bolts do not simultaneously come into contact with a metal chassis or mounting framework. This causes a shorted turn which greatly reduces efficiency and may cause irreversible damage to the transformer windings.

**3/2**  
Electronic  
Fundamentals

3/2 - C	Components
3/2 - C - PC	Passive Components
3/2 - C - PC - T	Transformers

## 3/2 - 0

### Ohm's Law

#### Formula

The basis of electronics involves the relationship between voltage, current and resistance. This relationship is expressed in Ohm's Law.

If you've been around electronics you'll have seen this law expressed and shown in more than one way. Some books present its most basic form as:

$$E=RI$$

others as a circle with the symbols in place. A few books will replace the "E" with a "V", because this component represents voltage. (The "E" stands for electro-motive force.)

Some like the  $E=RI$ , and remember it as "Erie." Others prefer to swap the R and I around to make  $E=IR$ , and remember it as sounding like "ear." The two are the same. For this manual we will use the most common form,  $E=RI$ , since this is used most often. In this, E represents the voltage, R the resistance, and I the current (inductance).

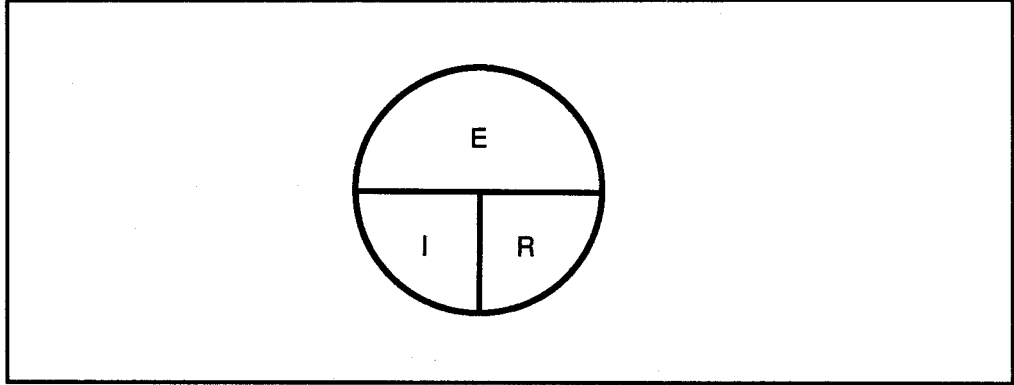
With this equation, you can derive the other two parts of the formula by algebraic juggling.

This means, simply, that you apply the rule that if you multiply or divide one side of an equation by something, you must do exactly the same to the other side of the equation. If you take the original formula  $E=RI$  and divide each side by R, the Rs cancel out, leaving you with  $E/R=I$ . From this you can calculate the current flow by dividing the voltage by the resistance.

Likewise, if you divide each side of the original formula by I, the Is cancel out and you come up with  $E/I=R$ . Or, voltage divided by current equals resistance.

As mentioned above, this can also be represented with a circle. You need only to place a finger over the component you wish to calculate. What is left in the circle is the way you get it.

For example, place your finger over the E in Figure 1, showing that you want to



**Figure 1:** Ohm's Circle

calculate voltage. What remains is the R next to the I. Multiply to solve for E.

Or, place your finger over the I (meaning that you want to calculate the current). What remains now is the E over the R, which tells you to divide the voltage by the resistance.

### Conductors/ Insulators

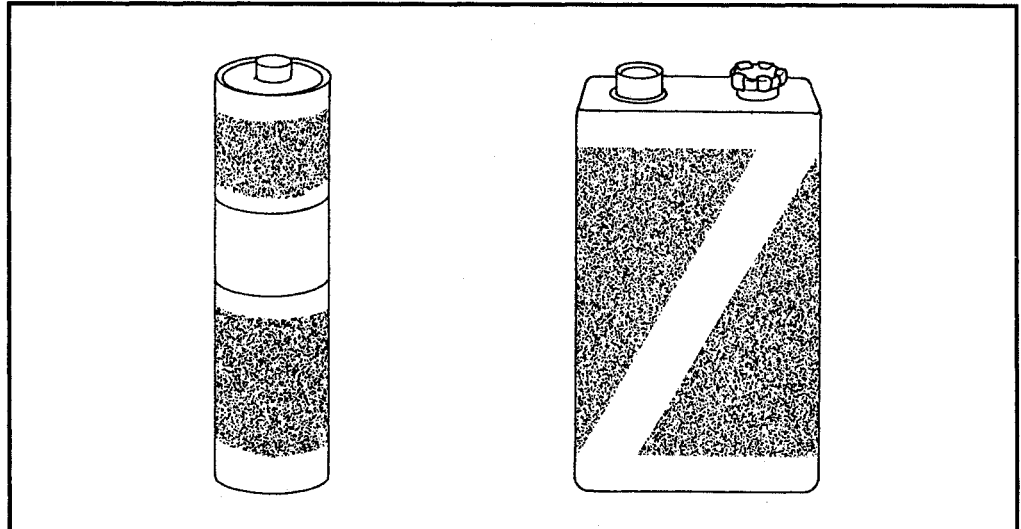
Materials which allow the flow of electricity are conductors; those which do not allow this flow are insulators. No substance known is either a perfect conductor nor a perfect insulator. However, among the best conductors are the metals, with the best of those being gold and the most common being copper. Examples of good insulators are air, rubber and certain plastics.

It should be noted that both conductance and resistance can be affected by temperature. This is one reason why some devices work just fine when first turned on and then fail after being on for a while (or vice versa).

A current may be produced within a conductor by connecting it to a source of voltage. As stated earlier, this is the electromotive force (abbreviated e.m.f.). To work there must be a complete circuit. This is because of the potential difference (p.d.).

### Examples

In Figure 2 a standard 1.5 V cell is shown. The post at one end is the positive terminal and the flat area at the other end is the negative. Until the battery is connected to a complete circuit, nothing happens. Within a circuit there is a potential difference between the positive and the negative of 1.5 V. Touch the probes of a VOM to the two terminals and the VOM becomes the circuit and you can measure the voltage. The same is true for each component in the circuit, which brings us back to Ohm's Law.

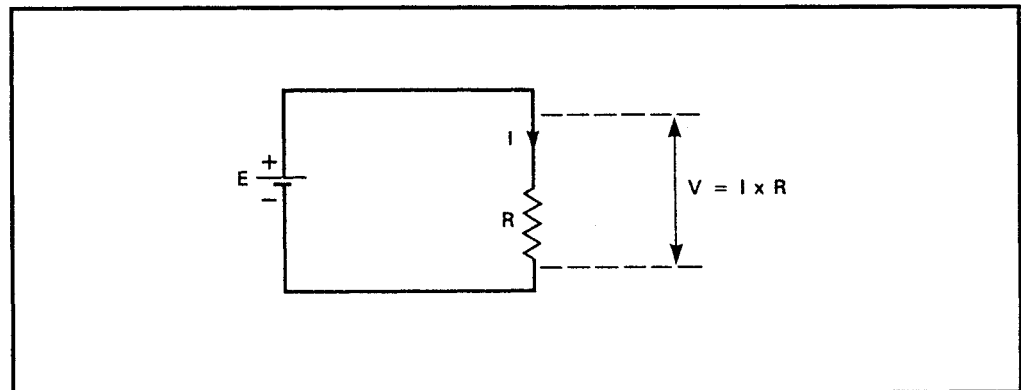


**Figure 2:** A battery holds potential voltage. It just "sits there" until a circuit is made.

The amount of current flowing in the circuit is proportional to the voltage (e.m.f.) applied and the resistance in the circuit or component through which that current flows.

Figure 3 shows a battery connected to a resistance. This resistance can be a complete circuit or a single component. Assume that the battery is a 6-V source.

If the resistance is nearly zero, the current flow is very high. For example, replace  $I=E/R$  with  $I=6/.001$  (1/1000th of an Ohm). The current trying to flow is 6000 amps. An average battery can't produce this, but it means that the wire



**Figure 3:** A basic circuit

will become hot and the battery will quickly drain. This is very nearly a dead short. Now replace the value of the resistance with a circuit or component of 100,000 (100 K $\Omega$ ). Now the current flowing is 0.00006 A.

Try one for yourself. Imagine a 12 V source connected to a 10,000  $\Omega$  load. What is the current?

The formula is  $I=E/R$ . In this example E is 12 and R is 10,000. By dividing the current is 0.0012 A (1.2 mA).

You can switch and juggle the values in Figure 3 to explore Ohm's Law more completely. You may need to know, for example, what voltage is needed to produce a current of 0.1 A in a circuit of 10 K $\Omega$ . To do so, the voltage becomes the unknown, which means that to find it you use  $E=RI$ . The solution then becomes  $E=0.1 \times 10,000 = 1000$  V.



## 3/2 - PVC

### Power, Voltage, Current

#### Power

Energy is the ability to do work. It is usually measured in joules. Power is the rate at which this happens and is most often measured in watts when dealing with electronics. Once again there is a direct relationship between power and the voltage and current flowing.

This is expressed in the formula:

$$P=IE$$

(Most often this is expressed as  $P=EI$ , but “pie” is easier to remember.)

In this formula, power (P) is equal to the current (I) multiplied by the voltage (E). Thus, if 1 A is flowing with a source voltage of 12 V, the power used is 12 W. As with Ohm’s Law, the formula can be juggled algebraically to produce:

$$I=P/E \text{ and } E=P/I$$

From the latter two you can calculate the current when the wattage and voltage are known and can calculate the voltage when the wattage and current (amperage) are known.

#### Batteries

Although there are standards, batteries come in a variety of sizes and configurations. The materials used also differ. The essential structure is a positive and a negative with an electrolyte in between.

The most popular is the zinc-carbon cell. In this case the outer “can” is zinc and negative; the central post is carbon and positive. This combination produces 1.5 VDC per cell, whatever its size or configuration. The AAA, AA, C and D sizes are all 1.5 VDC (nominal); the 9 V type is actually a multi-cell battery (it has six 1.5 V cells inside the casing).

9 V batteries are the least expensive. They also have a relatively short lifespan and can be greatly affected by temperature. Heat can reduce their shelf-life; cold will reduce their life in service.

All batteries can leak. Zinc-carbon cells display even more of a tendency for this, especially after they have been discharged. It’s important to remove the batteries

from any device that is stored for a period of time. This rule is even more important when the batteries being used are zinc-carbon.

More expensive are alkaline cells. They have a longer shelf-life, a longer in-service life. They are less affected by temperature and work in a larger range of temperatures than zinc-carbon cells.

When other materials are used, the actual voltage may be slightly lower. Ni-cad batteries, for example, have a nominal voltage of 1.2 V per cell. These will work in most applications, however, and have the advantage of being rechargeable. Although they are more expensive to purchase, in the long run they may save money.

Besides the initial cost, the greatest drawback with ni-cads is that they work and work, then suddenly go dead. There is little or no warning. With zinc-carbon or alkaline cells, the power level decreases slowly. With a ni-cad, the level stays relatively constant even as the battery is draining, then suddenly drops below the functional level.

Ni-cads require some additional care, especially when it comes to recharging them.

It is preferable to allow the battery to discharge completely before attempting to recharge. The reason is that there is a possibility that if a partially discharged cell is recharged, it can develop a "memory." To over-simplify, this means that the battery "thinks" it has been fully discharged while actually a partial charge is left. When put back into use, it may "see" this spot as fully discharged. Then, instead of giving 6 hours of service, it may give only 2 hours (depending on how much charge was left).

For much the same reason, it's also a good idea to fully discharge the ni-cad before storing it for extended periods. Then, when the cell is to be used again, you'll get better service from the cell if you take the time to go through several charge/discharge cycles.

### AC (Alternating Current)

Batteries are used for portable equipment, and sometimes to serve to hold the back-up memory. For most household devices, AC will be used—sometimes directly but usually as the source of electricity for a power supply which converts the incoming AC into the needed values of DC.

The nominal value in the standard household outlet is 117 VAC. This will vary

slightly depending on the time of day. Large appliances and a few other devices require higher voltage and are supplied through two 117 VAC power lines, creating a nominal 234 VAC.

Don't worry if you read about 110, 115, 117 or 120 (and the linked 220, 230, 234, and 240). They are all the same. The use of other numbers is largely arbitrary.

Of greater importance is the power frequency. In North America, a 60-cycle frequency is used; in Europe and other places the frequency is 50 cps (cycles per second). The two are not compatible. If the device is designed for 50-cycle power, you will need a converter for it to work in North America.

This electricity is run through a fuse or circuit breaker. The purpose is to protect the wires in the building, with a secondary purpose of protecting the device plugged into the outlet. The size (value) of this breaker can be almost anything but is most often 15 or 20 A for the standard outlet.

Fuses and/or breakers may also be found in the devices. The size is determined by the unit's needs but will normally be 1 or 2 A and rarely more than 5 A.

## Waveforms

A waveform is a graph showing the variation in voltage or current. It is a highly useful graph when it comes to diagnosing circuits in that it tells you what the voltage and/or current is doing in the circuit.

The shape of the wave (such as that on an oscilloscope) may be of any variety. Common are straight, sine (sinusoidal), triangular, ramped, pulsed or complex. They may be repetitive or nonrepetitive.

If repetitive, the time for a wave to complete one cycle is its frequency. This is easily seen in the sine wave, such as is present in the incoming electricity to your home wall outlet. The value rises above zero, drops below it then up again at a rate of 60 times (cycles) per second. This is 60 cps or 60 Hz.

The relationship of time and frequency is expressed by the formula:

$$t = 1/f$$

in which the time (t) is determined by 1 divided by the frequency. By algebraic juggling,  $f = 1/t$ , in which the frequency is 1 divided by the time needed for one complete cycle.

This gives you the period of the wave. As an easy example, the 60 Hz signal of

standard AC has a period of 1/60th of a second ( $t=1/60$ ). A signal with a frequency of 3 MHz (3,000,000 cps) has a period of .000003 s ( $t=1/3,000,000$ ).

It should be noted that 117 VAC isn't really 117 V. The value is constantly changing. It reaches a peak above +117, drops through zero to a value below -117 and rises again. The 117 VAC is the effective (rms) value for one-half of the cycle (either the positive side or the negative side).

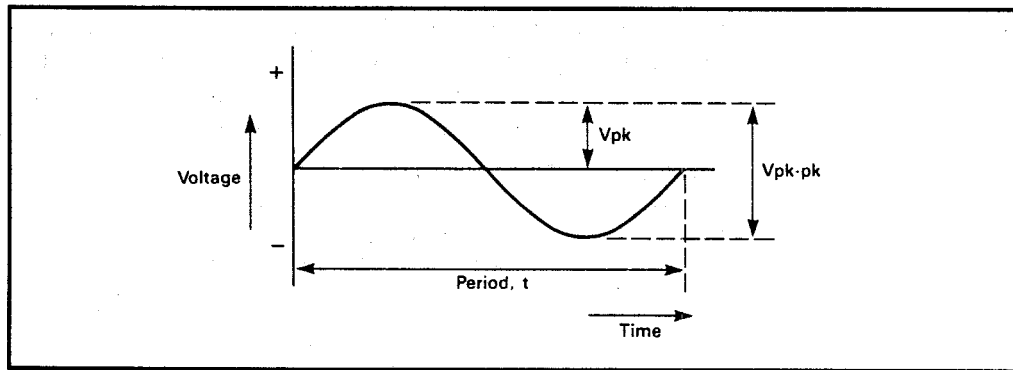


Figure 1: Sine wave parameters

## 3/2

## Electronic Fundamentals

### 3/2 - QUS

### Quantities, Units, Symbols

#### Quantities

The quantities present in electrical circuits are measured in terms of standard units based on the International System (SI). Units are often abbreviated to a single letter (e.g., A to represent amperage, V for voltage, etc.). The same is true in electrical formulas. The following table lists the units, abbreviations and symbols commonly used in electronics.

Unit	Abbr.	Symbol	Notes
Ampere	A	I	Unit of electric current (a current of 1 A flows in a conductor when a charge of 1 C is transported in a time interval of 1 s).
Coulomb	C	Q	Unit of electric charge or quantity of electricity.
Farad	F	C	Unit of capacitance (a capacitor has a capacitance of 1 F when a charge of 1 C results in a potential difference of 1 V across its plates).
Henry	H	L	Unit of inductance (an inductor has an inductance of 1 H when an applied current changing uniformly at a rate of 1 A/s produces a potential difference of 1 V across its terminals).
Hertz	Hz	f	Unit of frequency (a signal has a frequency of 1 Hz if one complete cycle occurs in a time interval of 1 s).
Joule	J	E	Unit of energy
Ohm	$\Omega$	R	Unit of resistance
Second	s	t	Unit of time
Siemen	S	G	Unit of conductance (reciprocal of resistance)
Tesla	T	B	Unit of magnetic flux density (a flux density of 1 T is produced when a flux of Wb is present over an area of 1 square meter).
Volt	V	V	Unit of electrical potential (e.m.f. or p.d.).
Watt	W	P	Unit of power (equivalent to 1 J of energy consumed in a time of 1 s).
Weber	Wb	$\phi$	Unit of magnetic flux

## Multiples and Sub-Multiples

### Units

In 1960, the 11th *Conférence Générale des Poids et Mesures* adopted the *Système Internationale d'Unités* as an international system of units, called the SI units. Two changes were made, one in 1967 to change Kelvin to kelvin and 1971 to add the seventh SI standard.

Seven basic quantities are used for the SI units:

- length in meters
- mass in kilograms
- time in seconds
- temperature in degrees kelvin
- current in amperes
- luminous intensity in candelas.
- amount of substance in moles.

The following table gives the terms used for multiples of a unit.

### Multiples of a Unit

Multiple	Prefix	Symbol
$10^{18}$	exa	E
$10^{15}$	peta	P
$10^{12}$	tera	T
$10^9$	giga	G
$10^6$	mega	M
$10^3$	kilo	k
10	deca	da
$10^{-1}$	deci	d
$10^{-2}$	centi	c
$10^{-3}$	milli	m
$10^{-6}$	micro	$\mu$
$10^{-9}$	nano	n
$10^{-12}$	pico	p
$10^{-15}$	femto	f
$10^{-18}$	atto	a

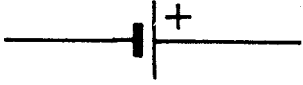





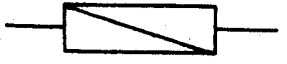

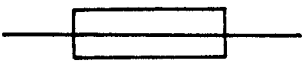
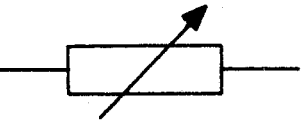


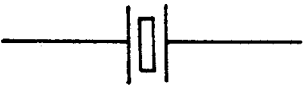



The SI system of units is slowly replacing other systems, but the English (Imperial) system is still used throughout North America.

Listed on the following page are some of the standard conversions to convert commonly used units in the English system and the multiplier to convert to SI units.

## Conversion Factors

From	To	Multiplication Factor
inch	meter	$2.54 \times 10^{-2}$
foot	meter	$3.048 \times 10^{-1}$
yard	meter	$9.144 \times 10^{-1}$
mile	kilometer	1.609
nautical mile	kilometer	1.852
mile	meter	$2.54 \times 10^{-5}$
fathom	meter	1.8288
square inch	square meter	$6.4516 \times 10^{-4}$
square foot	square meter	$9.290 \times 10^{-2}$
square yard	square meter	$8.361 \times 10^{-1}$
square mile	square meter	2.590
cubic inch	cubic meter	$1.6387 \times 10^{-5}$
cubic foot	cubic meter	$2.832 \times 10^{-2}$
cubic yard	cubic meter	$7.645 \times 10^{-1}$
gallon (US)	cubic meter	$3.785 \times 10^{-3}$
gallon (UK)	cubic meter	$4.5 \times 10^{-3}$
pound	kilogram	$4.536 \times 10^{-1}$
ton	kilogram	$1.0161 \times 10^3$
pound/square foot	kilogram/square meter	4.882
pound/cubic foot	kilogram/cubic meter	$1.60185 \times 10$
bar	newton/square meter	$1.3332 \times 10^2$
foot pound	kilogram meter	$1.383 \times 10^2$
torr	newton/square meter	$1.332 \times 10^2$
kilogram force	newton	9.8066
pound force	newton	4.4482
British thermal unit	joule	$1.0548 \times 10^3$
calorie	joule	4.1868
horsepower	watt	$7.457 \times 10^2$
kilowatt hour	joule	$3.60 \times 10^6$
therm	joule	$1.0551 \times 10^8$
mile/hour	kilometer/hour	1.609
knot	meter/second	$5.15 \times 10^{-1}$
electron volt	joule	$1.602 \times 10^{-19}$
gilbert	ampere	$7.9577 \times 10^{-1}$
gauss	tesla	$1.0 \times 10^{-6}$
maxwell	weber	$1.0 \times 10^{-8}$
footcandle	lumen/square meter	$1.0764 \times 10$
footlambert	candela/square meter	3.4263
lambert	candela/square meter	$3.183 \times 10^3$

**Symbols**

	Cell		Fixed resistor
	Battery		Fixed resistor (alternate symbol)
	Fuse		Fixed resistor, non-inductive
	Fuse (alternate symbol)		Variable resistor
	Fuse (alternate symbol)		Variable resistor (alternate symbol)
	Antenna		Potentiometer
	Quartz crystal		Potentiometer (alternate symbol)
	Coaxial Cable		Preset resistor



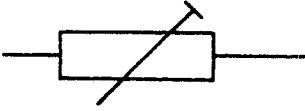





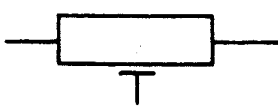



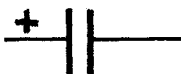


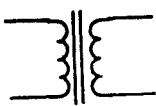
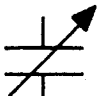

Section 3 • Electronic Repair Basics

**3/2**  
Electronic  
Fundamentals

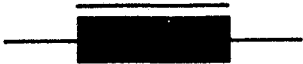
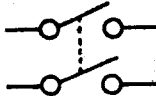
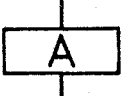
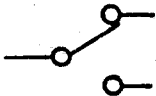
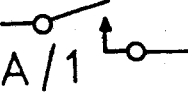

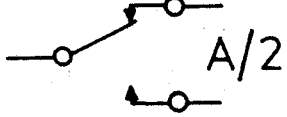
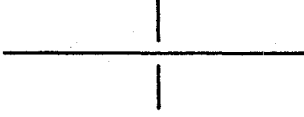



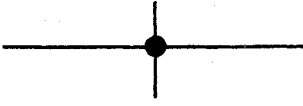




3/2 - QUS

Quantities, Units, Symbols

**Symbols**

	Preset resistor (alternate symbol)		Variable capacitors, ganged
	Motor (if letter "G" it is a generator)		Feed-through capacitor
	Preset potentiometer		Inductor (coil), air cored
	Preset potentiometer (alternate symbol)		Inductor with ferrite core
	Fixed capacitor		Inductor with metal/iron core
	Fixed capacitor, electrolytic type		Inductor with variable ferrite core
	Trimmer or preset capacitor		Transformer
	Variable capacitor		Inductor, air cored

**Symbols**


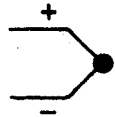



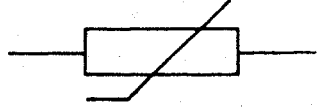
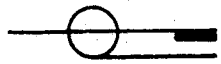
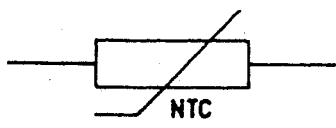





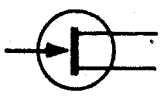
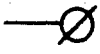
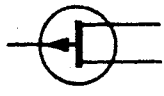
	Inductor, iron cored (choke)		Toggle switch (Double Pole Single Throw: DPST)
	Relay coil (A)		Toggle switch (Single Pole Double Throw: SPDT)
	Relay contact 1 for relay coil (A) By convention relay contacts shown in rest position		Two wires crossing and not connected
	Relay contact 2 for relay coil (A)		Two wires crossing and not connected
	Morse key		Two wires crossing and not connected
	Push to make switch		Two wires crossing and connected
	Push to break switch		Two wires crossing and connected
	Toggle switch (Single Pole Single Throw: SPST)		Three wires joined

**3/2**  
Electronic  
Fundamentals

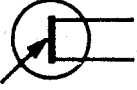












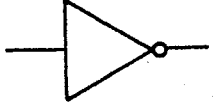

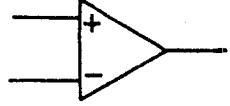
3/2 - QUS

Quantities, Units, Symbols


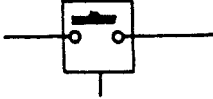










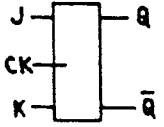

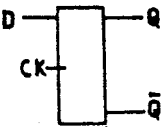
**Symbols**

	Ground		Thermocouple
	Chassis ground		Thermistor
	Supply line (positive or negative)		Thermistor (alternate symbol)
	Coaxial plug		Thermistor with a negative temperature coefficient. PTC shows it is a positive temperature coefficient and V shows it is a voltage dependent resistor
	Coaxial socket		PNP Transistor
	Plug		NPN Transistor
	Socket		P-channel field effect transistor (FET)
	Terminal or terminal pin		N-channel field effect transistor (FET)

**Symbols**

	Unijunction transistor (UJT)		Silicon controlled rectifier (SCR) Also called a thyristor
	Single-gate MOS FET		Bidirectional breakover diode (diac)
	Dual-gate MOS FET		Bidirectional thyristor (triac)
	Diode		Filament lamp
	Zener diode		Neon lamp
	Varicap diode (varactor)		Non-inverting amplifier
	Light emitting diode (LED)		Inverting amplifier
	Photodiode		Operational amplifier (op-amp)

**Symbols**

	2-input AND gate		Analog switch
	2-input NAND gate (NotAND)		Meter (not center zero)
	2-input OR gate		Buzzer or bell (alternating current)
	2-input NOR gate (NotOR)		Buzzer or bell (direct current)
	2-input EXOR gate (ExclusiveOR)		Loudspeaker
	Schmitt trigger symbol found in Schmitt trigger gates		Headphones
	JK flipflop		Microphone
	D-type flipflop		

**3/2**  
Electronic  
Fundamentals

---

3/2 - QUS

---

Quantities, Units, Symbols

---

---

**3/3**  
**Troubleshooting**  
**Techniques**

## **3/3**

# **Troubleshooting Techniques**

---

### **Introduction**

One of the most popular misconceptions concerning electronic troubleshooting is that good technicians are born not made. There is nothing magical in the ability to track down problems. The implication is that the skills of the technician cannot be acquired unless the person already has the electronics equivalent of a “green thumb”.

Nothing could be further from the truth. Indeed anyone of moderate intelligence and manual dexterity can successfully carry out even the most complex electronic repairs. The secret lies with adopting the correct approach to troubleshooting. This is the real key to successful fault finding on electronic equipment.

The goal of this section is to explain the techniques which may be applied in order to locate and successfully repair faults on a wide variety of electronic equipment. Some techniques are appropriate to certain types of equipment. Others may be applied more generally.

With experience, the right technique will become second nature. A trained technician may not even be aware or conscious of which technique is being applied. He or she may seem to get right to the cause without even thinking. By applying a little logic and reasoning, and by gaining experience, you can do the same.

### **Approach To Troubleshooting**

Before examining the most effective troubleshooting techniques, understanding the overall approach is important. Fault finding is a disciplined, logical process in which “trial fixing” should never be contemplated.

The generalized process of fault finding is illustrated in the flow chart of Figure 1. The first step is to identify the defective equipment—and ensure that the equipment really is defective! This latter may sound obvious, but in many cases, the problem may be that the operator isn’t using the equipment correctly, that it has become disconnected, or that there is some maladjustment.

Where several items of equipment are connected together, it may not be easy to pinpoint the single item that is faulty. For example, if a word processor is providing no output to the monitor, the operator might assume that something

**3/3**  
Troubleshooting  
Techniques

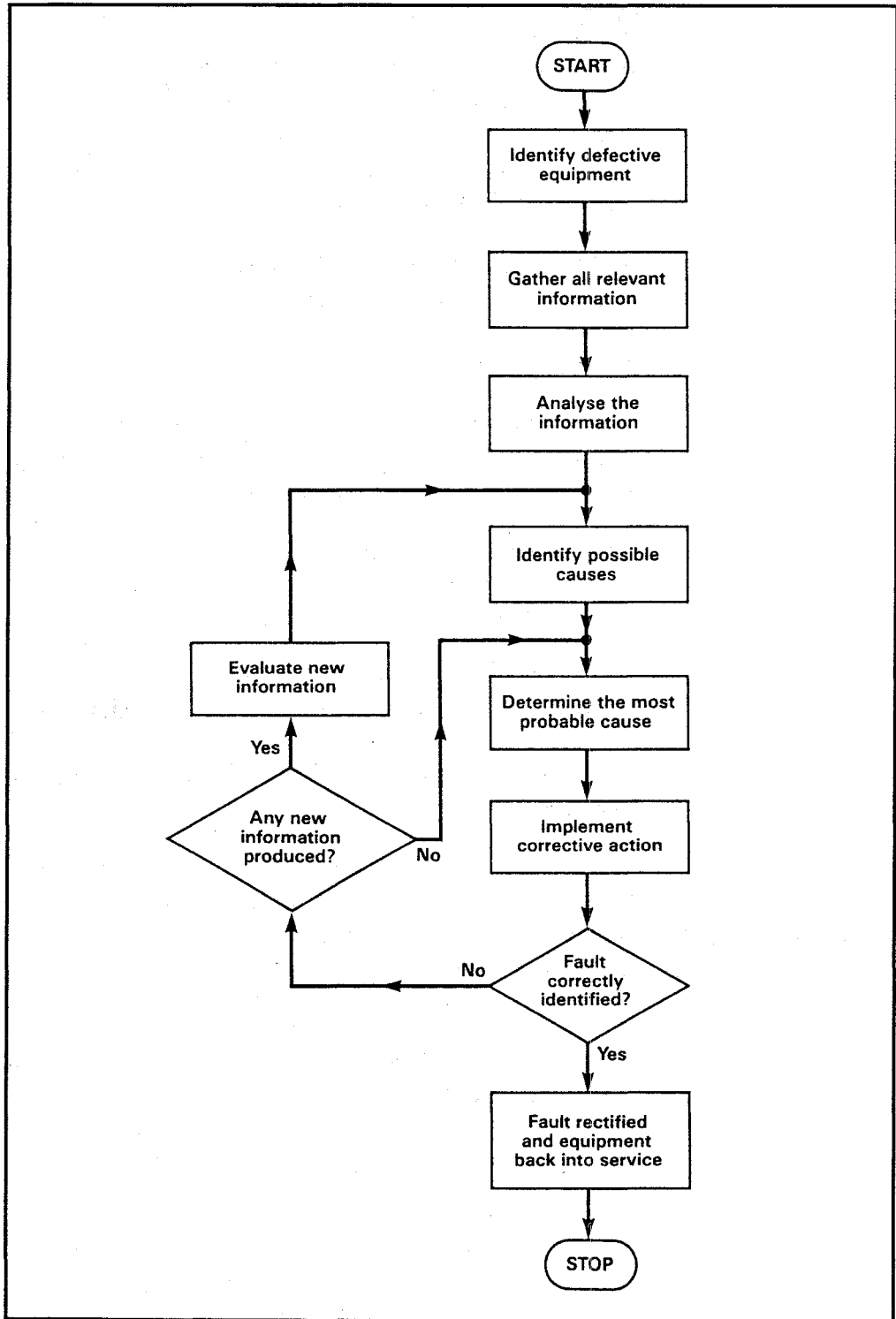


Figure 1: A flow chart can be used to diagnose



is wrong with the computer. This might be, but the trained technician would not make such an assumption. The problem could be with the person operating the system, could be in the software, in the computer, in the monitor driver board, in the monitor, in the keyboard, in the printer or elsewhere.

The second stage is that of gathering all relevant information. This process involves asking questions such as:

- In what circumstances did the equipment fail?
- Has the equipment operated correctly before?
- Exactly what has changed?
- Has there been a progressive deterioration in performance?

The questions are crucial. They should explore all avenues and eventualities, particularly when the technician has no previous experience with the equipment in question. The answers help to build a conceptual model of the symptoms, before and after the problem occurred. General knowledge coupled with knowledge about the specific equipment (e.g., its performance specifications) can often point to a unique cause of the problem.

Once the information has been analyzed, the next stage involves separating the “effects” from the “cause”. Here the aim is simply that of listing each of the possible causes. Once this has been accomplished, the most probable cause can be identified and focused upon. Corrective action should be applied to this cause alone. Such action may require adjustment, alignment or component removal and replacement.

Next it is necessary to decide whether the problem has been correctly identified. A component may have failed (open circuit or closed circuit), or a fuse may have blown. Testing can confirm that the cause has been correctly identified. If so, the problem can be corrected and the equipment put back into service. If not, any new information that has been generated can be evaluated before reverting to the selection of the next most probable cause. In practice, the loop may have to be repeated several times before the fault is correctly identified. This is essentially a process of and elimination.

Repair is often a matter of finding out what is wrong by finding out what is not wrong. Then you can make things right.

Always begin with the obvious (such as ensuring that the equipment is plugged in), and progress step-by-step in an orderly fashion. It should be noted that modern equipment is often IC based. At times, the overall circuit is so complex

that some repairs are impossible unless you have access to the specialized testing equipment for that circuit board. Other times, the chip(s) may be soldered to the circuit board in a way that makes it impossible to replace the chip without more specialized equipment. Still other times the ICs are proprietary and replacements are not available. In all of these cases your troubleshooting will proceed to the PC board level, at which point the cure will be to replace the whole board. Often this is the most efficient and most cost-effective method in any case. This has to be decided on a case-by-case basis. Often the deciding factors include the extent of the damage, the complexity of the circuit board, and the cost of the replacement board.

### Block Diagrams

Block diagrams are frequently used to show the functional sub-systems present within a complex electronic device. Each major sub-system is given its own block and is identified by its function. The flow of signals is generally from left to right, but this can be modified when necessary. What matters most is that the direction of flow from block to block is correct.

Figure 2 shows the block diagram of an FM stereo receiver. The path of the signal, from antenna to loudspeaker, can be clearly identified as it passes from stage to stage. The amplitude of the signal from the antenna is likely to be in the range of a few hundred microvolts, while the signals arriving at the speakers can be several volts. As the signal passes from stage to stage, its level is gradually increased. (Note that not all stages provide amplification. Several of the blocks have other functions which may actually attenuate, or reduce, the signal. Further, the function of some of the blocks is to modify frequency.)

The FM signal at the antenna and at the RF preamplifier stage have a frequency in the range of 98 MHz to 108 MHz. The output signal from the mixer has a frequency of 10.7 MHz, and contains the same information that is present on the signal at the antenna (and thus at the input to the preamp). After IF amplification, amplitude limiting, demodulation and stereo decoding, the signal fed to the AF amplifier stages are in the audio range—typically between 100 Hz and 10 kHz.

Most of the blocks shown in Figure 2 have input and output. This is essential in the case of amplifier stages. Other blocks, such as the oscillator stage, have output only. This stage produces a signal to be mixed to create the IF heterodyne signal at 10.7 MHz. Similarly, the balance, stereo indicator and VU meter all have input but no output (other than for the operators, which are not electrical outputs and thus do not come into consideration in the block diagram).

The power supply has input and output. The outputs are taken to nearly every

**3/3**  
**Troubleshooting**  
**Techniques**

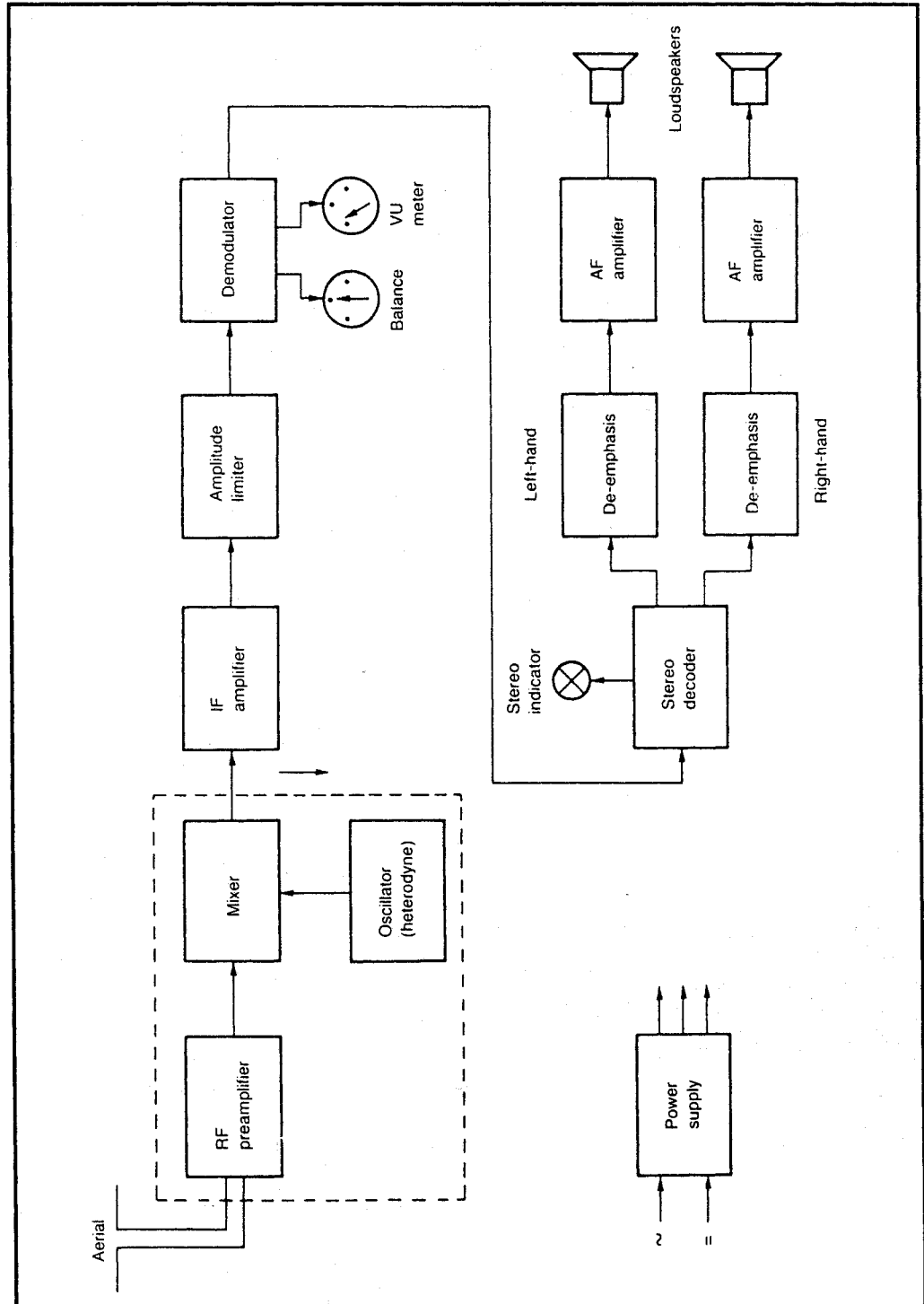


Figure 2: A typical block diagram—in this case of a stereo FM radio receiver

other block. To avoid over-complication the links are not shown on the diagram but are assumed.

Troubleshooting is often based on identifying the functional block which has failed. By making a few simple checks at the points interconnecting the blocks, we are quickly able to locate the block that has failed. Once this is accomplished, the circuitry of that block can be investigated further.

For example, assume that the stereo receiver has developed a problem and no output is produced from either audio channel. The first check should be with the power supply to assure that it is providing the necessary output voltages. The reason is that if the power supply is not functioning properly, one or more stages can also fail to function.

The next step would be to test for and identify signals at various stages, beginning with the most obvious and the easiest. You might consider starting at the speakers. However, since (in this example) both channels are missing, it is relatively unlikely that the speakers—or the cables feeding them—would fail at the same time. The most logical conclusion would be that the failure is in an earlier stage.

If one channel is functioning but the other is not, it may be worth testing for a signal at the speaker (which can be done with a VOM or more simply by replacing the speaker unit and/or cable). If this produces no results, probe at the appropriate volume control.

For example, if the left channel is dead, you can inject a signal at the left channel volume control. A signal of about 500 mV at 1 kHz is a viable test to see if the stereo decoder and de-emphasis circuits are working. If all seems well, the conclusion is that the left channel amplifier is probably at fault.

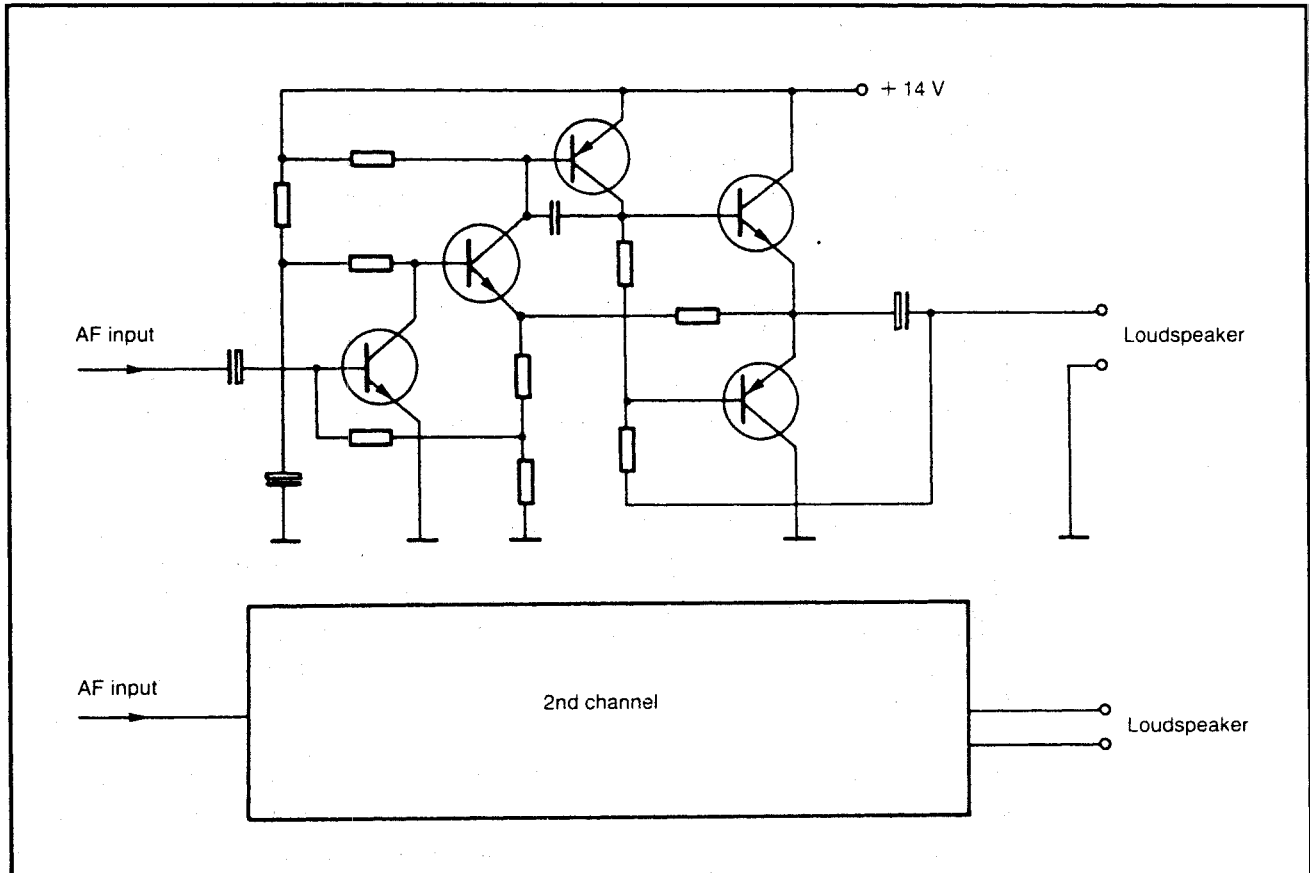
By dividing the overall device into blocks, you can eliminate blocks and track the problem. Once you have tracked the problem to a particular block, you can dig deeper, this time using a circuit diagram.

**Circuit Diagram**

In the above example, with one channel failing, the block diagram would lead you to the specific block, which would in turn lead you to the circuit diagram for that block. In this case, your search would bring you to the AF amplifier, as shown in Figure 3.

Circuit diagrams are to the technician what the road map is to the motorist. They

**3/3**  
**Troubleshooting**  
**Techniques**



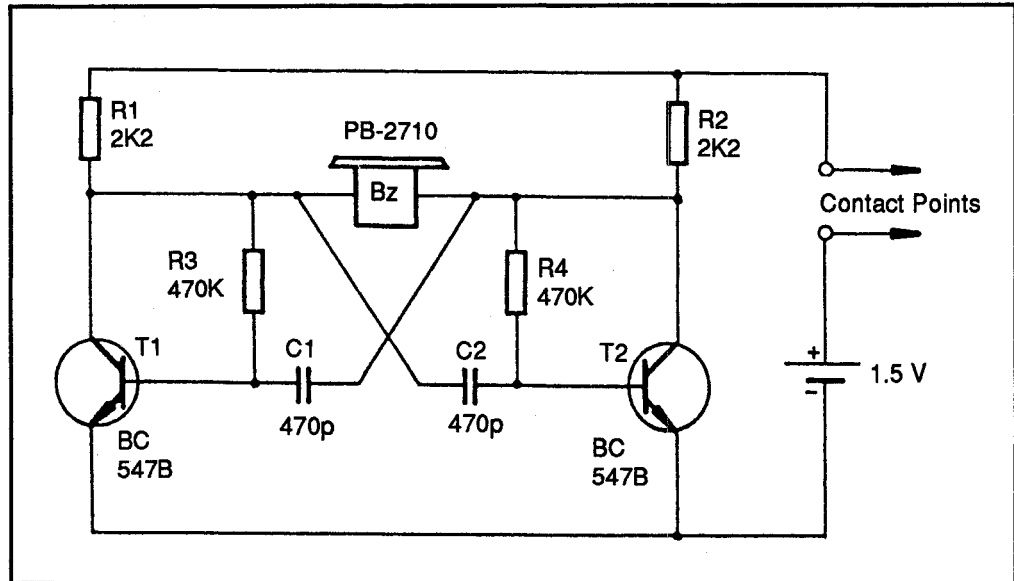
**Figure 3:** Circuit diagram of the AF amplifier functional block

provide a means of finding the way around a circuit, and clearly show the components used and the links which exist between them. The components are usually identified with a part number (e.g. R1, C12, IC46, etc.) and also with a value or device reference (e.g., 1 k $\Omega$ , 100 nF, etc.).

Figure 4 shows the circuit diagram of a simple audible continuity tester. This diagram shows two transistors (connected in what is known as an astable multivibrator arrangement). The transistors are labeled T1 and T2.

The emitters are connected to the negative supply. The collectors (opposite emitter) are taken from R1 and R2 from the positive side of the supply. The circuit diagram tells you all of this, and often more.

Sometimes a parts listing is attached. This repeats much of the information from



**Figure 4:** Circuit diagram of an audible continuity tester

the circuit diagram and often adds other information. In the above example, you know that R1 and R2 are 2.2 k $\Omega$  resistors but you don't know their tolerance or power rating. A parts listing will show them to be (in this example) of 5% tolerance and 0.25 W.

Reading the diagram depends on which convention is used. In some, for example, the resistor is shown as a saw-tooth; in others the resistor is a rectangular box. Electrical connections may be shown with a dot, while solid lines crossing indicates no connection. Or, the diagram may use solid lines crossing to show a connection and arched lines showing no connection. This may sound confusing but you will soon come to understand the conventions.

As another example, Figure 5 shows the circuit diagram of an electronic battery charger designed for use with 12 VDC lead-acid batteries (such as those for your automobile). This circuit shows a number of different techniques, both analog and digital. The circuit also uses a number of ICs.

The circuit obeys the usual convention of signal flow from left to right. The input voltage is shown at the extreme left, with the output DC voltage at the right. The analog/digital signal processing (based on IC2 and logic gates N1 to N8) also follows the left-to-right convention.

The negative supply is shown as an inverted T rather than as a continuous electrical connection. All components which are shown with the inverted T

**3/3**  
**Troubleshooting**  
**Techniques**

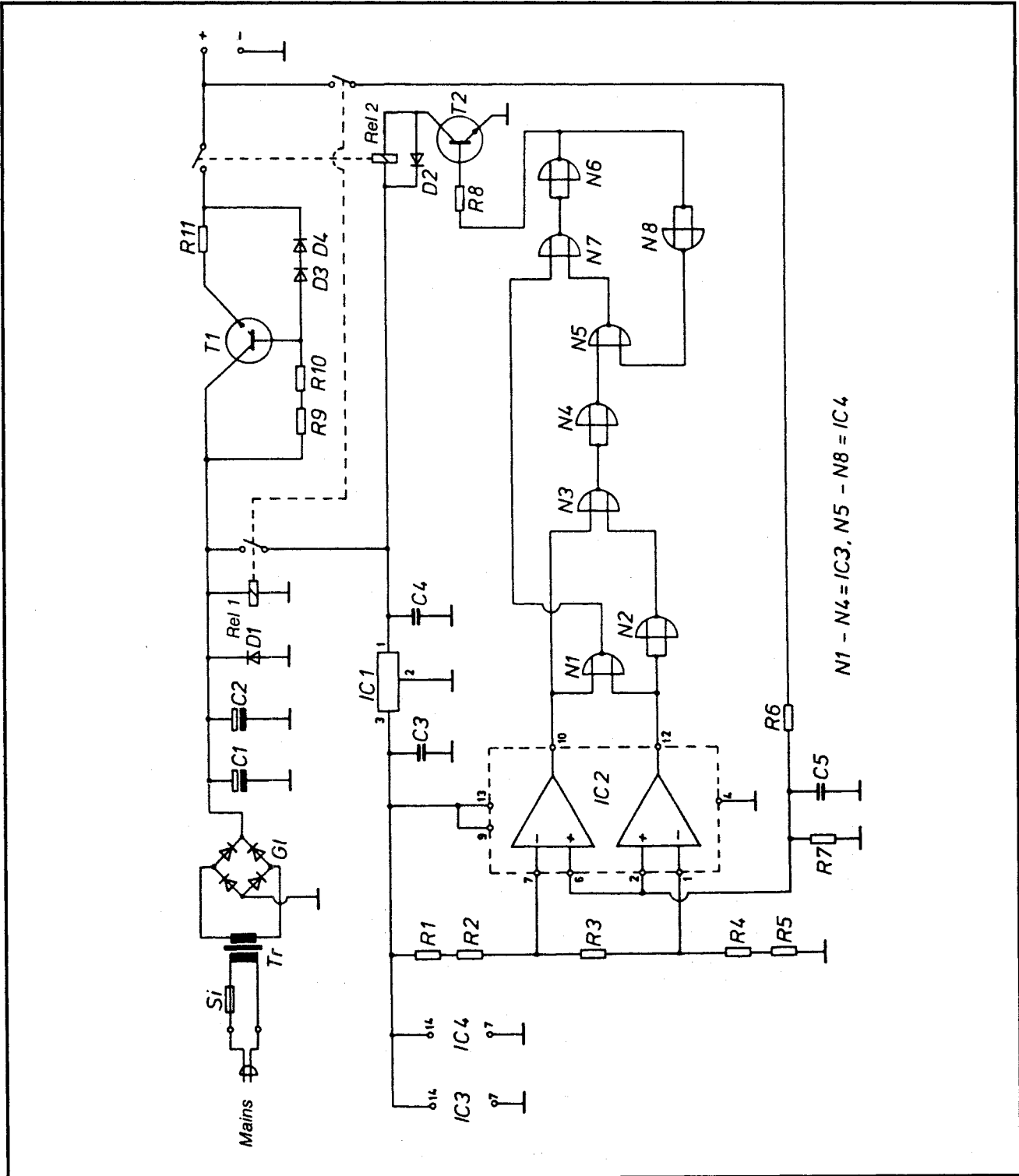


Figure 5: Circuit diagram of a 12 V automotive battery charger

3/3

Troubleshooting Techniques

symbol (C1, C2, D1, etc.) are linked together via this common connection. This reduces the number of lines in the diagram and thus reduces confusion.

In some equipment this kind of common connection is returned to the main ground. In this case the ground is isolated, and is called a chassis ground. Care must be taken to not misinterpret symbols indicating common connections. In most cases no harm is done by using a different ground, even if it's not on the same circuit board. All that matters is the zero potential. In other cases (such as television receivers) there may be good reason to maintain isolation between chassis ground and earth ground.

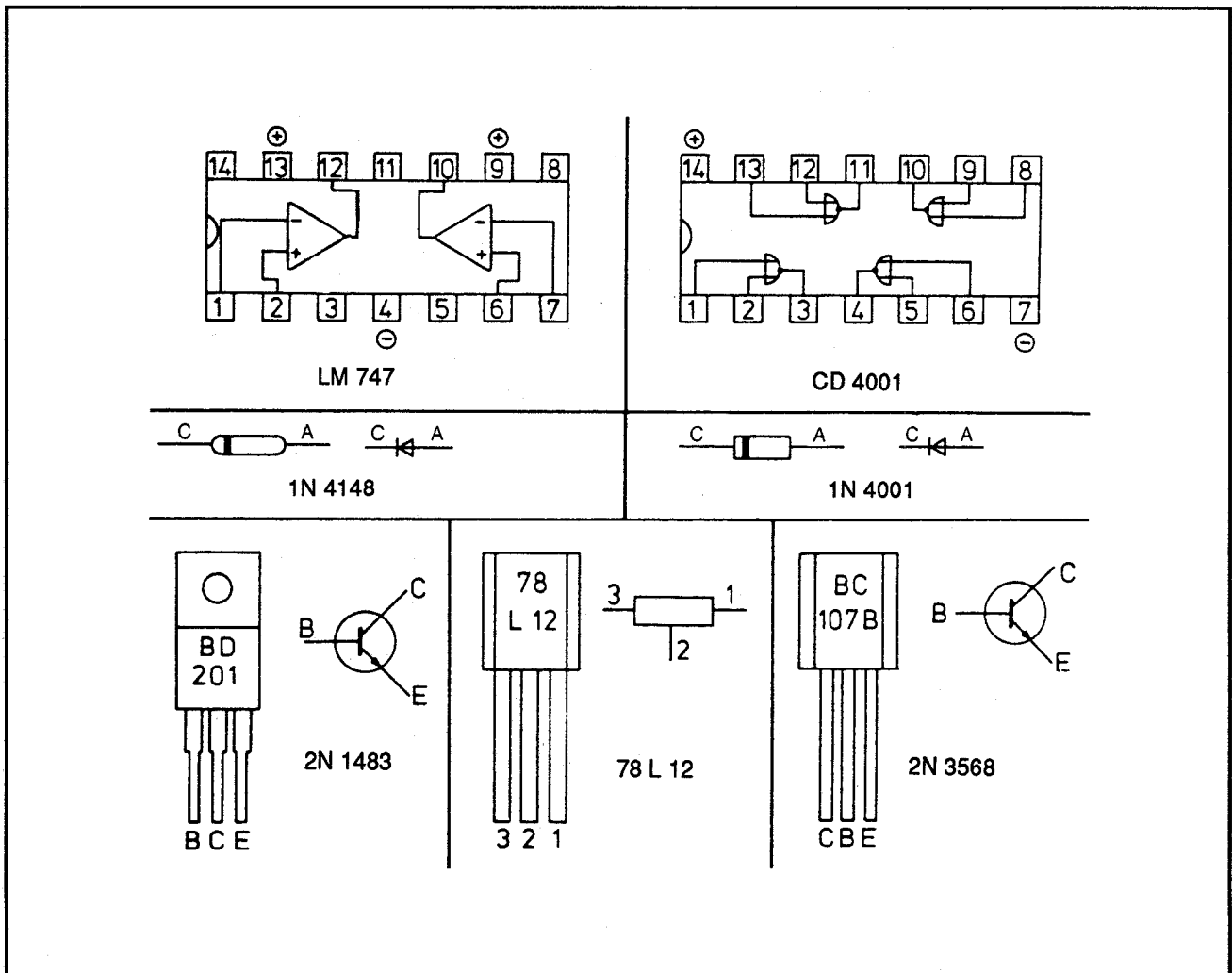


Figure 6: Component outlines and pin connections for Figure 5



**3/3**  
**Troubleshooting**  
**Techniques**

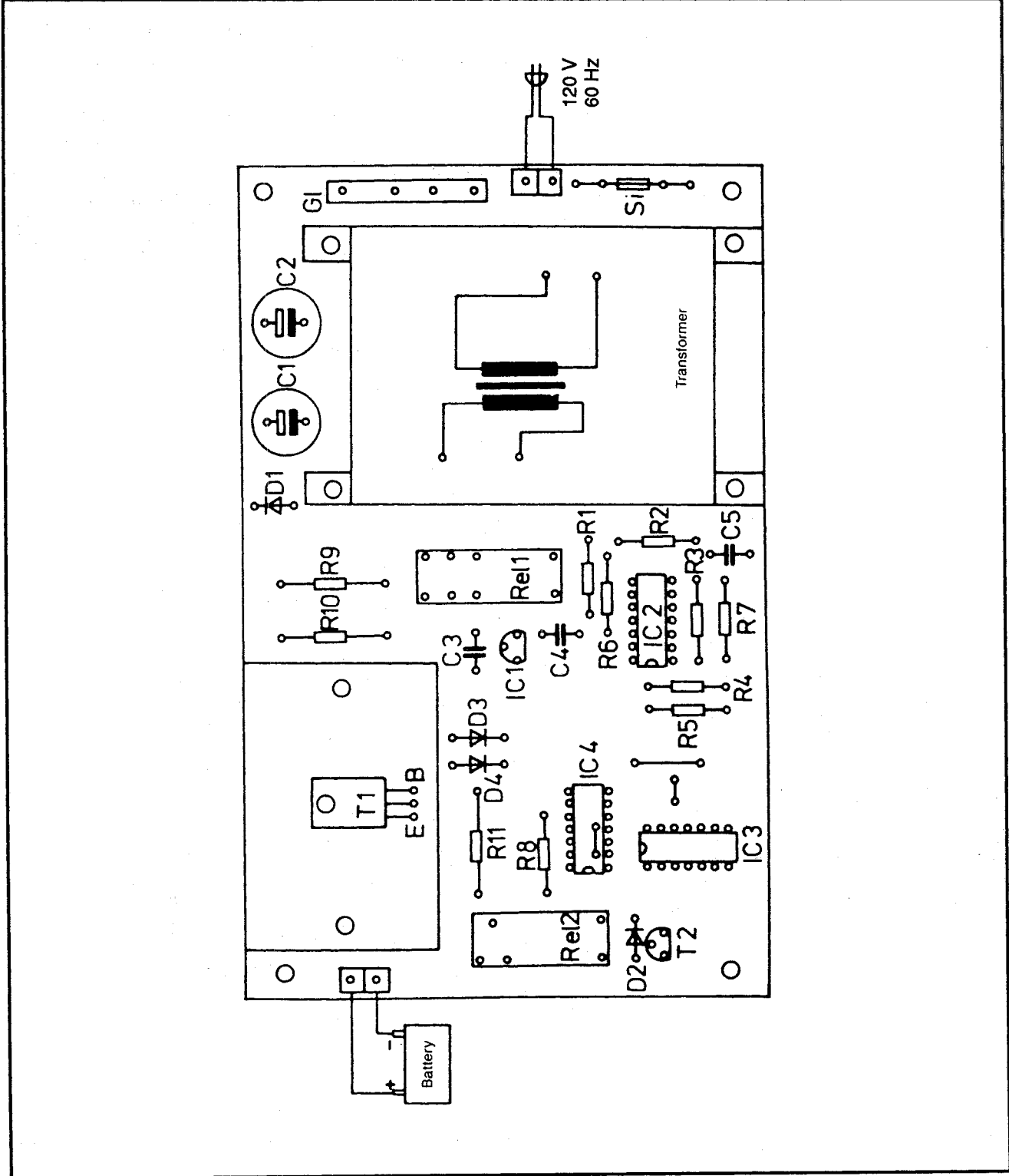


Figure 7: PC board component layout for the 12 V battery charger

3/3

Troubleshooting  
Techniques

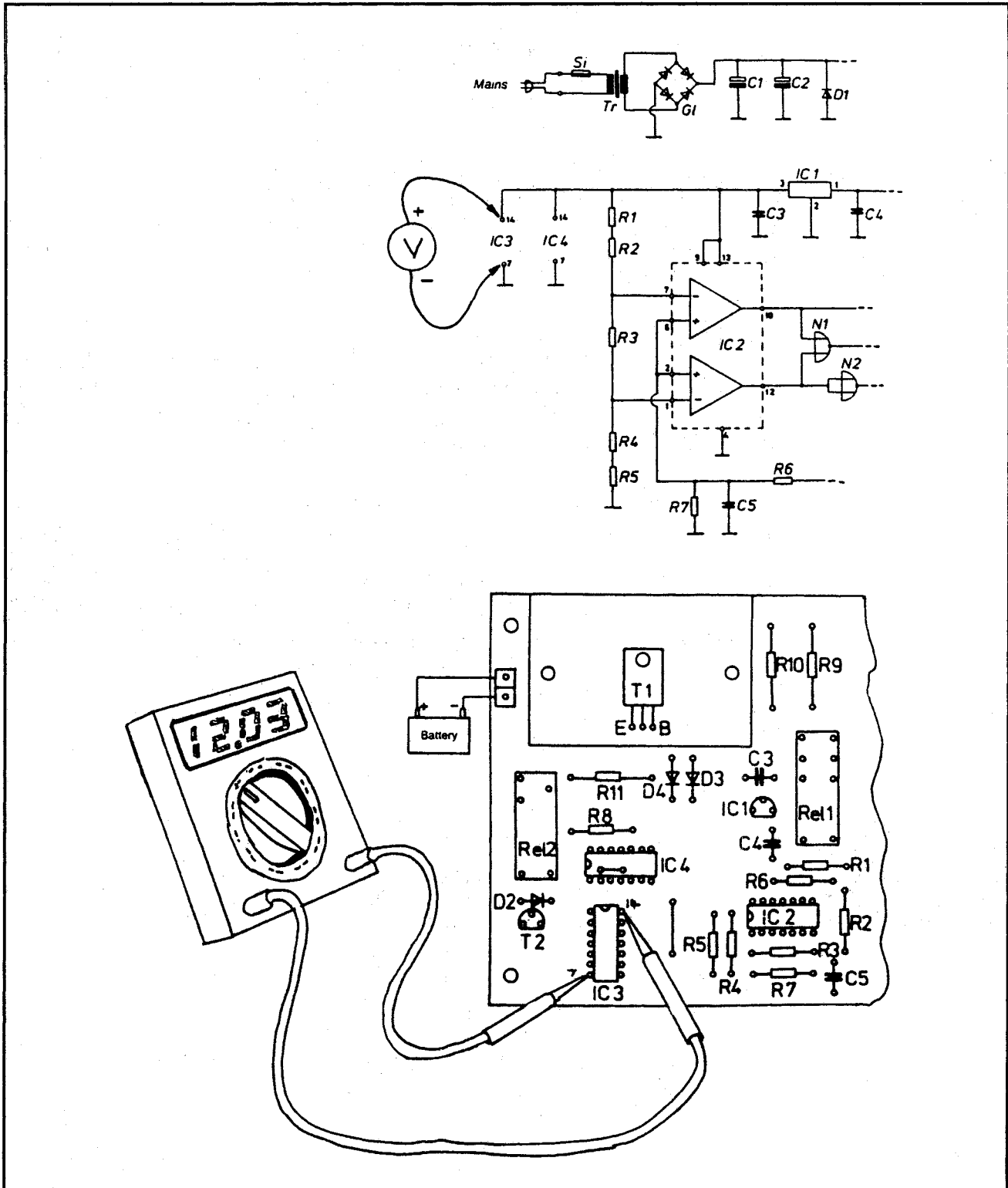


Figure 8: Measure voltage on IC3

**3/3**  
**Troubleshooting**  
**Techniques**

Circuit diagrams are often accompanied by detailed component drawings to indicate pin connections. An example of this is shown in Figure 6. Such drawings can often help the technician identify components and their proper placement in the circuit.

Also common is to show drawings of the actual circuit board(s) as in Figure 7. Although the technician see much the same thing looking at the actual board, a less-complicated drawing can often aid in tracking possible problems. Such a drawing is especially valuable when the PC board is not silk-screened with the component labels.

Occasionally the set of circuit diagrams and PC board layouts are accompanied with drawings that show specific tests to be carried out. Figure 8 shows an example of a composit drawing, with the schematic at the top, a partial PC board drawing at the bottom, and the actual test being carried out. (In this case, IC3 is being tested for power between pins 7 and 14.)

**Flow Charts**

A flow chart for troubleshooting was shown earlier in this section. These charts are used in many branches of electronics, particularly in computing (where they are also used to describe the action of a program). They help to identify the sequence of steps used for operation, or for finding the cause of a problem.

A number of standard symbols are used to accomplish this. Additional symbols might be used to indicate input/output, storage, displays, etc. (Some of these are not used in troubleshooting.) Several conventions are used when creating or following flow charts. Among these:

- Direction of flow is indicated by means of arrows.
- Repeated branches (loops) should be drawn clockwise.
- Symbols must indicate the activity which they represent, and often have the activity written inside, or beside, the symbol.
- Flow charts should have one start point and one stop point.
- Each decision symbol should have one input and two outputs, but should not be based on more than two (compound) decisions (outputs).
- Off-page connectors should be numbered so that flow may continue logically from one sheet to the next.
- The direction of flow should be from top to bottom, or from left to right.

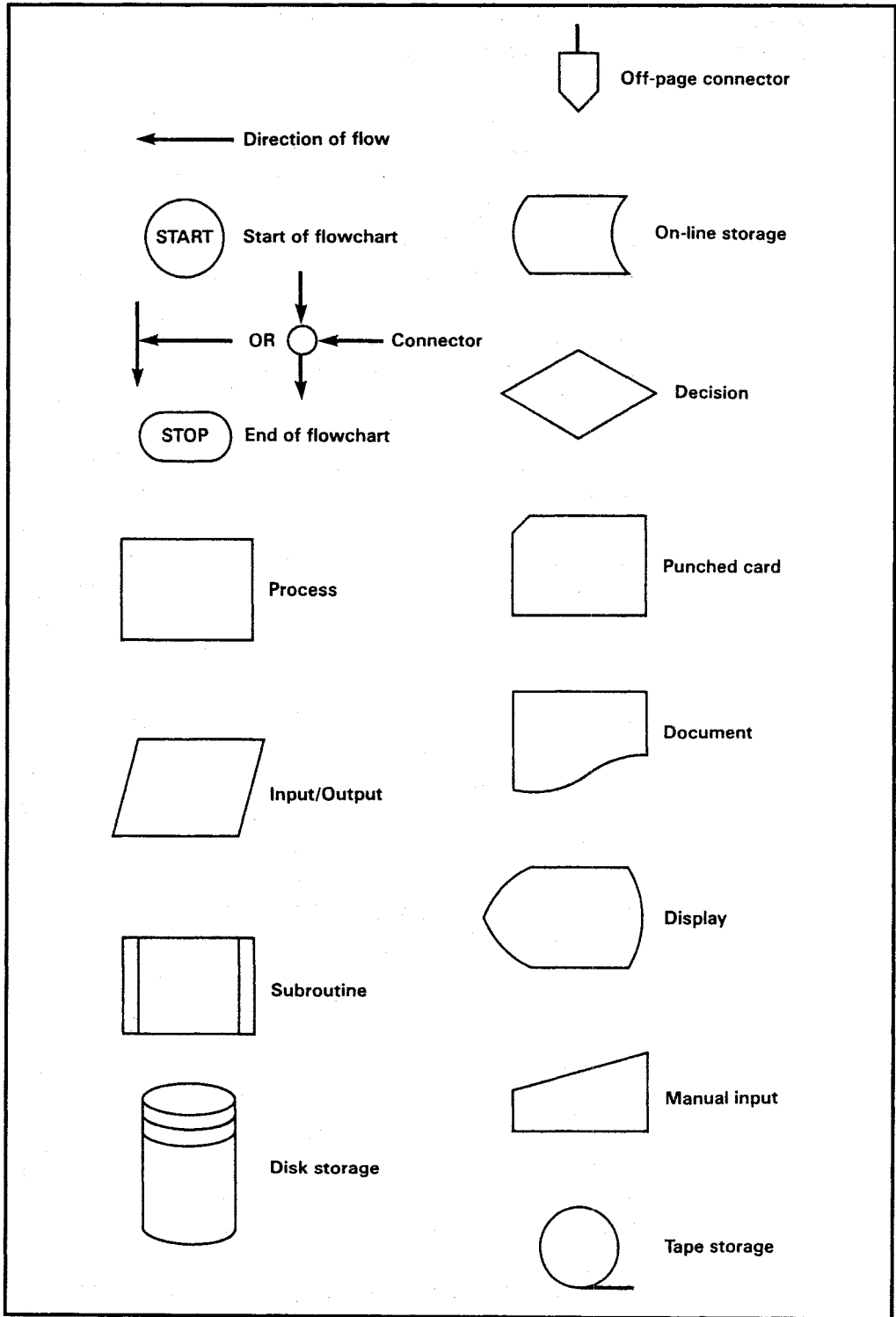


Figure 9: Some typical flow chart symbols

**3/3**  
**Troubleshooting  
Techniques**

**Component  
Identification**

When troubleshooting to the component level, it is essential that you are able to identify the components correctly.

The wide range of components, packaging and coding can be confusing enough to the experienced technician and can be completely baffling to the newcomer. Fortunately, in the majority of cases PC boards have a silk-screened component level which clearly identifies each component and even certain test points. (The latter may or may not be of value depending on the extent of the labeling. Often you will need the specific service manual for these to be of use.)

For example, if you're not sure just what that small black cylinder is, and the printed legend calls it "Q206," you will know that it is a transistor of some sort. If the component is labelled "C206," it's a capacitor.

Further complicating matters is that different manufacturers use different labels. A transformer is often be labeled T or TR, but both labels denote a transistor.

Although the PC board labels are helpful, they have limitations. As above, you will often need the specific service manual to discover exactly what Q206 is. You know that it is a transistor, but not which type. Sometimes you can guess—most of the time you cannot.

The component will (hopefully) have a coded number or color scheme (see Section "3/2 *Electronic Fundamentals*"). This may or may not be visible. At times the component will be soldered in such a way that the label is down and can't be seen unless you remove the component from the board. Other times it will be badly stamped (blurry) or even worn off.

The code, if present, might be multiple. That is, the component might carry more than one code. (This is particularly common with ICs.) It may have a device code, including the manufacturer's prefix, its generic number, electric/package details, etc. (The second may—or may not—be a date of manufacture code.)

As an example, if the device is marked MC6809P and 8931, the first identifies the manufacturer (Motorola) and the IC (6809). The second tells you that the chip was manufactured in the 31st week of 1989.

Worse yet is when the manufacturer has purposely left off or obliterated the marking. This is done to make it impossible for a technician to identify the component's type or function. The reason is often that the manufacturer wants to be sure that its own technical staff does the repair work. (This same reasoning is often used to prevent technicians outside the company from obtaining service

---

---

---

---

manuals.) In the opinion of most people, this is a bad practice spurred largely by greed. It is also short-sighted in that it doesn't take into account that some end users may not have access to company technicians; nor does it take into account that the company might go out of business. A term you may hear is "boat anchor." This signifies an older piece of equipment that cannot be serviced because information and/or replacement parts are unobtainable, making the equipment useful only for its weight.

Another reason the component marking may not be legible is physical damage, such as from overheating. Unfortunately, if the component is damaged to this extent, you probably won't be able to test it to see what it is and what it does.

Sometimes you can identify an unmarked or damaged component by examining and testing the circuitry around it. In this case it is necessary to identify the circuitry and the signals in and around it (including AC and DC voltages). This technique can often identify the most common components and integrated circuits.

For example, consider the case of an unmarked 14-pin DIP integrated circuit. The most common pin configuration calls for supply connections to be +V (often 5 V) going to pin 14 with pin 7 being the ground.

You can confirm this by using your VOM. First test between pin 7 and a known ground. You should read 0 V. Knowing this you can test between pin 7 and pin 14. If the reading is +5 VDC the device is very likely a digital IC, and is probably either TTL or CMOS.

The next step is to investigate the voltage and/or logic levels at each of the remaining pins. If a logic probe is available, this can provide a rapid indication of the logic levels (0 or 1) present. This gives you the pinout configuration. Hopefully this can be used to give you a match.

Care must be exercised when testing a component in this way. It would be easy to cause voltage and current to flow where it is not meant to flow. If this happens, you might damage a functional circuit.

### Component Substitution

In many cases it is possible to replace a failed component with an exact replacement. The use of "exact" is often critical. Unfortunately there are times when an exact replacement is unavailable. This is particularly true if the equipment is old or imported. In such cases you may have no choice but to substitute with a close rather than exact replacement. This is permissible in many cases, provided that several important factors are kept in mind.

---

---

---

---

In general, the replacement component must have the same value and function as the original. (You probably can't replace a 220  $\Omega$  resistor with a 1 k $\Omega$  resistor.) Its characteristics (tolerance, stability, etc.) must be at least as good as the original. You can upgrade the component, but never downgrade.

#### *Resistors*

Be sure that the replacement component has the same resistance value. Its tolerance must be at least as good, and can be better. While it's possible to replace a resistor of 10% tolerance with one of 5% tolerance, the opposite is not true. Likewise, if the original is rated at 0.50 W, you can substitute with a resistor rated at 1 W, but not with one rated at 0.25 W.

Keep in mind that in some applications other characteristics may also be important. For example, resistors used in the first few stages of an AF or RF amplifier should be of low-noise construction, and those for RF applications should also possess minimal inductance and capacitance.

In the case of testing and measuring equipment, resistors should not only be close-tolerance types but should also be of high stability. If their characteristics change with age (lower stability), over time the instrument will become less and less reliable.

#### *Capacitors*

Ensure that the replacement component has the same capacitance value as that of the original, and that its tolerance is the same or better. The working voltage rating must also be the same or better (greater). For example, a 100  $\mu$ F electrolytic capacitor rated at 25 V maximum working voltage can be used to replace a 100  $\mu$ F electrolytic capacitor rated at 15 V—but not the other way around.

Tolerance is rarely important when a capacitor is used for smoothing or decoupling. In timing applications (i.e., when the capacitor is used in conjunction with an oscillator, a wave-shaping circuit or a monostable arrangement) tolerance can be important. In such cases only close-tolerance components should be used.

In some applications additional characteristics may be important. Capacitors used in the first stages of an RF amplifier should possess minimal inductance while those employed in high-voltage applications (and in high impedance circuits in general) should exhibit very low current leakage values. Capacitors used for reservoir and smoothing applications should be adequately rated in terms of the AC ripple current that may be applied.

---

---

---

---

This should be equal to or greater than that of the original component. In the case of test and measuring instruments, capacitors should not only be close-tolerance types but should also be high-stability components. As with resistors, if the capacitors used here change with age or temperature, the instrument will become unreliable.

#### *Inductors*

The replacement coil must have the same value as the original. Its current rating is usually unimportant in low-power applications (such as AF filters) but can become critical in higher power applications (e.g., AC power line filters). The frequency range of the replacement coil is largely governed by the material of the core and the physical construction of the component. It is essential to use a core material which is rated for the frequency range concerned. This consideration applies particularly to ferrite cores where certain grades of ferrite become very lossy at high frequencies. If in doubt, always use a grade of material which is more highly rated. For example, a ferrite core rated as effective at 10 MHz is generally be suitable at 3 MHz.

In some applications additional characteristics (stray capacitance, winding loss resistance, etc.) may be important. Inductors used in the first few stages of an RF amplifier or a high gain audio amplifier may require magnetic screening in order to prevent radiation of stray magnetic fields and induced noise and hum. Some experimentation may be necessary in order to find the optimum position for mounting the coil.

#### *Transformers*

The replacement should have the same turns ratio, voltage/current ratio and rating as the original component. The power rating (VA) and frequency range are also important.

For audio and wideband applications, the frequency range of a transformer is largely governed by the material of the core and the physical construction. It is essential to use a core material suitable for the frequency range concerned. As with inductors, this consideration applies particularly with ferrite cores. Once again, when in doubt use a material which is better rated. Also as with inductors, factors such as stray capacitance, winding losses, etc. may be of concern. The comments about transformers in this case are the same as with inductors.

#### *Transistors*

Transistor substitution is fairly common, particularly with lower cost equipment. In some cases you may have a choice between a number of different transistors. At other times the replacement must be exact.



Among the considerations are:

Current Gain	Important for most applications. The replacement must have a current gain at least equal to the original at the nominal working collector current.
Maximum Voltage	Important especially in high voltage applications, including power supplies, power amplifiers, etc. The maximum rated voltage of the replacement must be the same as, or greater than, the original.
Maximum Power	Important for medium/high power applications, such as power supplies, power amplifiers, etc. The maximum rated voltage must be at least the same, or greater than, the original.
Maximum Frequency	Important for high frequency (e.g. RF) applications. The maximum rated frequency of the replacement transistor must be the same, or greater than, the original.
Noise	This is important in low-level RF and AF amplifiers. In such applications, the replacement should be designated "low-noise."
Package	In general, the package (case) should be the same as the original. This is especially true of the pin configuration. (Even if you know how to test for proper configuration, don't assume that someone else will know later.)

### *Integrated Circuits*

Substitution of ICs usually applies only to general purpose devices, such as logic gates and operational amplifiers. In every case it is important to be sure that the electrical characteristics (e.g., supply voltage and supply current) are compatible, and that the replacement component offers a specification which is at least equal to that of the original. For example, it is usually permissible to replace a standard TTL device (7400) with an improved version (74LS00). Similarly, improved versions of operational amplifiers can usually be used to replace the standard versions. It is important to note that in some applications this is not true, and that such a replacement may create new problems. A typical example of this is oscillation which may result when a high-gain/high-speed device replaces an older, slower, lower-gain component.

### *Other Components*

The same considerations apply to other types of components (diodes, fuses, speakers, etc.). In every case, it is necessary to proceed with caution, and to be sure that the replacement is correctly rated.

**3/3**  
Troubleshooting  
Techniques

---

---

---

---

**3/4**  
Soldering/  
Desoldering

3/4 - D

Desoldering

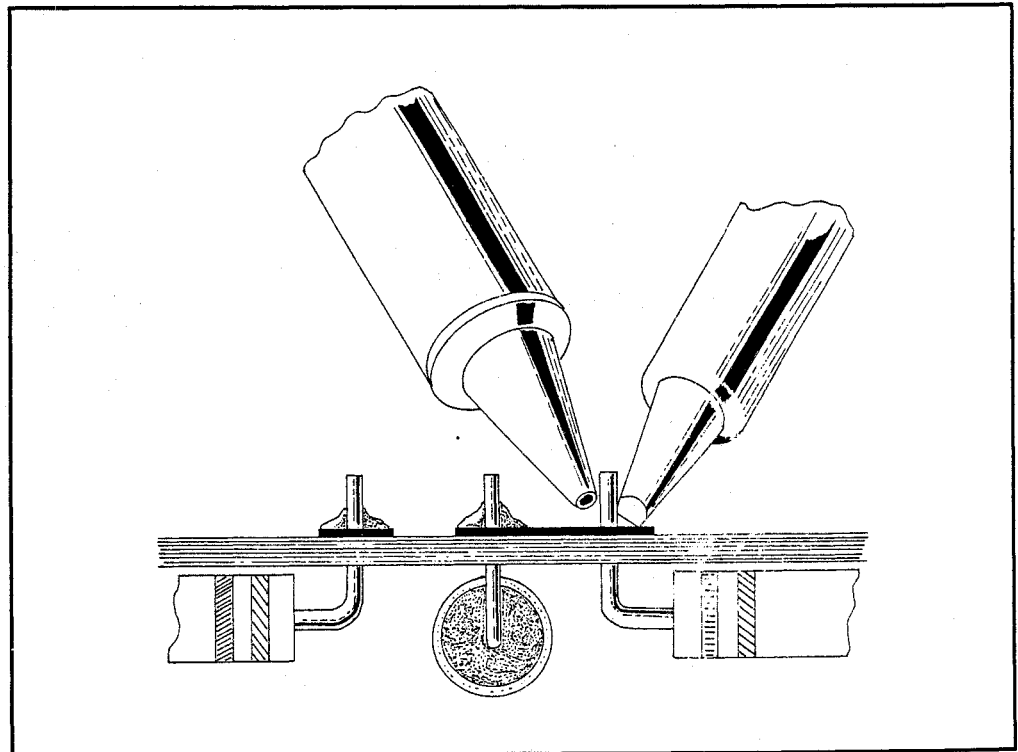
**3/4**  
**Soldering/Desoldering**

**3/4 - D**  
**Desoldering**

To replace a component, and for other purposes, it is sometimes necessary to desolder a joint. This can be accomplished in any of three ways.

**Desoldering Braid**

One is to use a desoldering braid, which makes use of a length of braided wire that is often coated with resin flux. Melted solder moves away from the joint and into the braid by a capillary action, leaving the joint clear and clean. The now-soldered braid is then clipped off, exposing a fresh portion.



**Figure 1:** To de-solder, melt the solder with the iron and use a solder sucker to remove the solder.

Desoldering braids come in several widths, from very fine (about 1/8") to fairly large (usually no more than 1/2"). You can find it in strips or on reels, with the reels usually being less expensive per unit length than the precut strips.

### Solder Sucker

Many prefer to mechanically remove the melted solder with a desoldering tool (as discussed in Section "4/1 Tools for Repair"). The solder sucker may be any of several types—from a simple syringe bulb to a tool connected to a vacuum line. One of the most popular has a metal or plastic body with a high-temp plastic nozzle.

The third method is to use a combination soldering iron and solder sucker. In this case the solder sucker is operated by a pump. This makes it both cumbersome and expensive. Because of this, such units are rarely found in small shops. In general, you won't need one.

### IC Removal

One advantage is that some such units can be equipped with a special bit meant specifically for ICs. These are difficult to remove manually, or one pin at a time. This same kind of tip is sometimes available for standard soldering irons, but without the suction. In this case the joints are heated simultaneously and the chip is removed from the board while the solder is still fluid. Of this this requires that the PC board be cleaned afterward, and the solder removed.

With some circuit boards it is preferable to replace the board rather than to attempt to de-solder a component, replace it and solder in the new one. In some cases the board is multi-layered, which increases the chances of damaging the board. Other times, the components are so tightly packed on the board that getting them out requires a fine tip on the soldering iron and a pair of tweezers. Again, there is an increased chance of causing damage.

### Tip

Causing damage is not important if the board is discarded anyway. However, keep in mind that some boards have a trade-in value. This trade-in value will usually disappear if the board is physically damaged.

**3/4**Soldering/  
Desoldering

3/4 - S

Soldering

**3/4**  
**Soldering/Desoldering****3/4 - S**  
**Soldering****Solder Types**

To produce a good solder joint we must first look at the solder to be used. The type of solder should be meant for electronics. This will usually be a blend of 60% tin and 40% lead. You may also find one of the new “lead free” solders to be suitable. Either way, it must be the type with a resin (also spelled rosin) core. Plumbing-type solder with an acid core is not suitable for electronics soldering. This core is the flux. It cleans the joint and then evaporates. This helps the solder to flow in and through the joint, making it mechanically and electronically sound.

**Solder Thickness**

Solder is available in various thicknesses, with two of most common being 18 swg and 22 swg. The smaller the number, the smaller the solder wire. For today’s high-tech electronics, the thinner 22 swg is much easier to use and provides a clean and bright joint. The thicker 18 swg solder takes longer to melt and may deposit too much solder when used on pre-tinned joints. If used on a circuit board, for example, you may create solder bridges.

**Tip** 

When using a soldering iron, position the unit so that no one trips over the cord. Be careful that the hot tip does not touch anything, particularly any electrical wires (including its own power cord).

The heat produced can be a danger to you as well, both directly (from touching the tip) and indirectly (having solder drip or splatter on you). If you do burn yourself, run cool water on the wound for at least 5 minutes. Other first aid steps may also be necessary.

**Solder Joint**

A soldered joint provides three things:

- an electrical path for conduction
- mechanical strength
- protection of the joint from corrosion

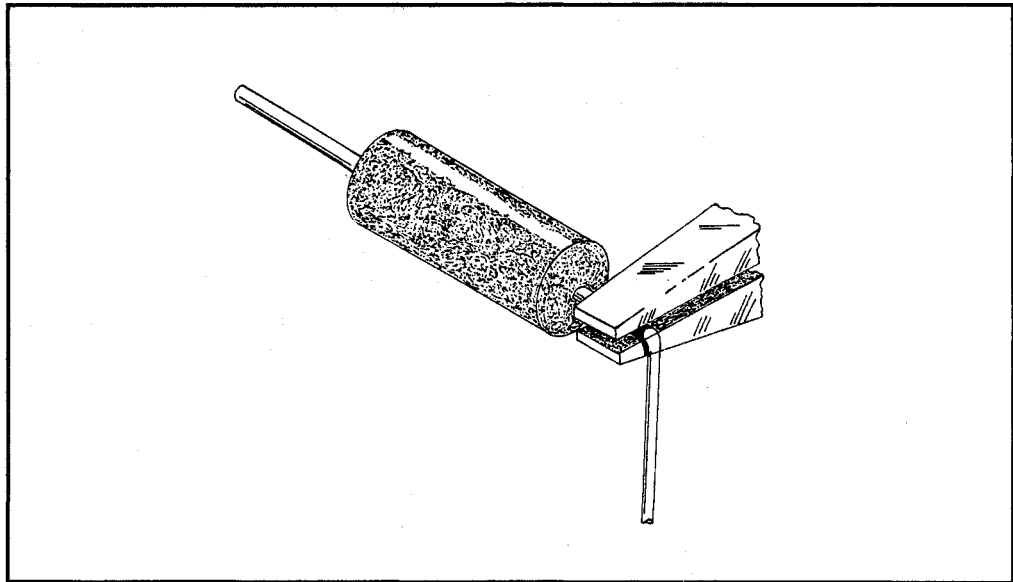
A poorly soldered joint is one of the most common causes of malfunctions.

Quite often what seems to be a component failing is nothing more than a poorly soldered joint.

Before soldering, be sure that the soldering tip is clean and shiny. It should remain this way at all times. Wiping the hot tip on a damp soldering sponge will help. It may become necessary to “re-tin” the tip from time to time.

**Example**

In the example that follows, a resistor is to be soldered into place in a PC board. The leads to the resistor are to be preformed. As in Figure 1, bend the leads into a “U” shape, so that they fit into the holes of the board.

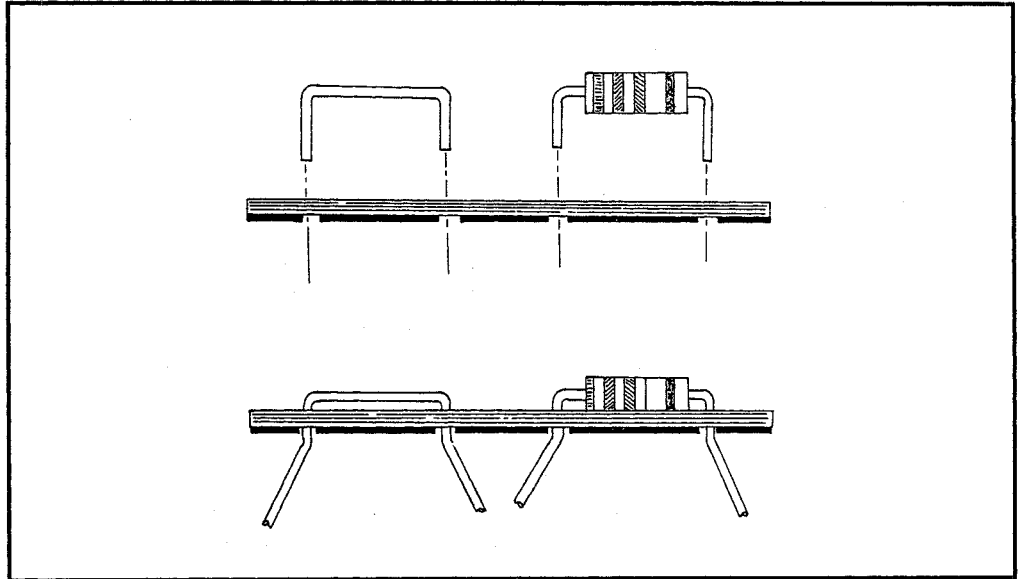


**Figure 1:** Preforming the leads

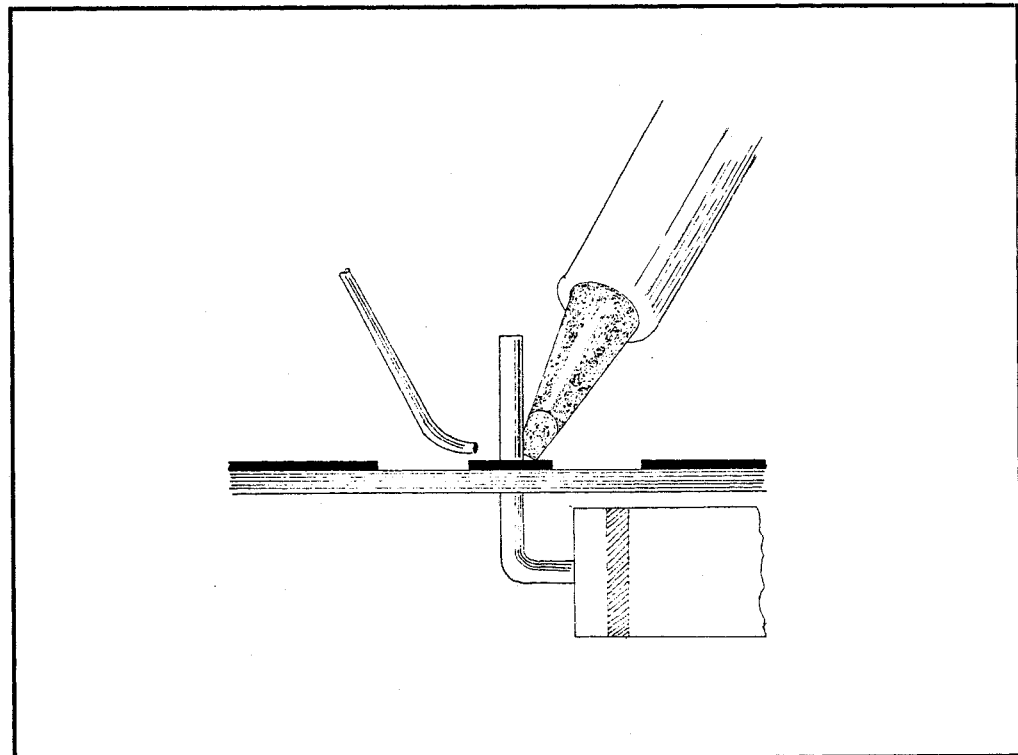
Figure 2 shows inserting a jumper wire (preformed as was the resistor) and the resistor. Note that the wire and resistor fit the holes exactly.

In most cases you will have to turn the board over to complete the soldering. It helps to bend the leads slightly (Figure 2) to hold the component in place.

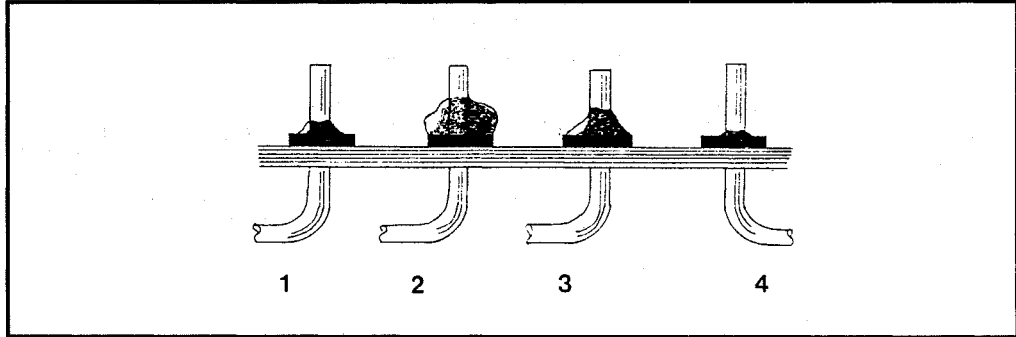
Hold the hot tip of the soldering iron to the wire and copper surface of the board for about 3 seconds (see Figure 3). Touch the solder to the wire (NOT to the soldering iron). If the wire and board have reached the right temperature, the solder will melt and flow around the joint. When this happens remove the solder wire and iron, and allow the joint to cool.



**Figure 2:** Fitting the components in the PC board holes, and bending the leads to hold them in place.



**Figure 3:** The soldering iron should heat the joint, with the joint melting the solder, not the soldering bit.



**Figure 4:** Good and bad soldering joints. 1. Too little solder; 2. Too much solder; 3. Good; 4. Too little solder, cold joint.

### Good Joint

A good joint should be smooth, shiny and globular in shape. (See Figure 4.) If it is dull or crystallized in appearance, you probably didn't use enough heat, or made the mistake of melting the solder with the tip of the soldering iron. Either way you have what is known as a "cold joint" (sometimes called a "dry joint"). Such a joint may work for a while but will sooner or later cause trouble. A cold joint does not carry any of the three goals of soldering. (Once the joint is complete, clip the excess leads very close to the joint.)

Soldering isn't difficult, but like any skill, it requires practice. The more you practice, the better you'll be.

### Checklist

1. Use the correct soldering iron and bit for the job.
2. Keep the tip clean and shiny.
3. The surfaces to be soldered must be clean and free of dirt, grease and rust.
4. The joint should be mechanically sound (although solder adds mechanical strength, do not rely on this alone).
5. The bit must make contact with all surfaces to be soldered.
6. The joint should melt the solder, not the bit.
7. The amount of solder should be correct—not too much, not too little.
8. Remove the solder and soldering iron quickly after the solder has melted—be careful to not overheat.
9. Do not disturb the soldered joint until the solder has solidified.



# Section 4

# Tools and Test Equipment

---

## Table of Contents

<b>4/1</b>	<i>Tools for Repair</i>
<b>4/2</b>	<i>Basic Test Equipment</i>
<b>4/3</b>	<i>Advanced Test Equipment</i>
<b>4/3 - DMM</b>	<i>Digital Multimeter</i>
<b>4/3 - FC</b>	<i>Frequency Counter</i>
<b>4/3 - LP</b>	<i>Logic Probe</i>
<b>4/3 - O</b>	<i>Oscilloscope</i>
<b>4/3 - SS</b>	<i>Signal Sources</i>

Section 4 • Tools and Test Equipment

**Table of Contents**

---

---

---

---

**4/1**  
Tools for Repair

## **4/1**

# **Tools for Repair**

---

### **Introduction**

Before you select your tool kit, it will help if you know which branch of electronics interests you most. For example, if you intend to work with large power mains, large cutters would be required. Those same cutters are useless if you work with small wires.

The range of possible fields is almost endless and continues to grow. The variety of tools and equipment needed grows with it. Suppose you decide to work with television sets. In the past you could get by with some basic equipment and perhaps a tube tester. Today you would need transistor testers, IC checkers, a logic probe and much more. If you choose to go into satellite television, fiber optics or radar you will be dealing with a different range of frequencies, which means that different equipment will be needed. Fortunately you don't have to make all of the decisions right now—nor do you have to invest in the complete tool kit all at once. You can build and add to it over time, buying more tools when necessary.

The test equipment is covered in Sections “*4/2 Basic Test Equipment*” and “*4/3 Advanced Test Equipment*”. The special test equipment needed is covered in the appropriate troubleshooting and repair sections. The basic tool kit is covered here.

The real key is to purchase the best you can afford. “Cheap” tools might work, but not as well. Not only will they have a shorter life span, they can actually cause damage to equipment. In many cases, they might have less expensive (and less sturdy) metal, covered with a thin layer of chrome. The metal beneath can bend or break if too much force is applied. Also, the shiny coating can flake off. If this gets inside a device many problems can occur. Another critical factor is to be sure that the handles are insulated when appropriate.

### **Wire Cutters**

One of the basic tools is the wire cutter. This tool falls into one of three main categories, depending mostly on the size of the wire being cut.

**4/1**

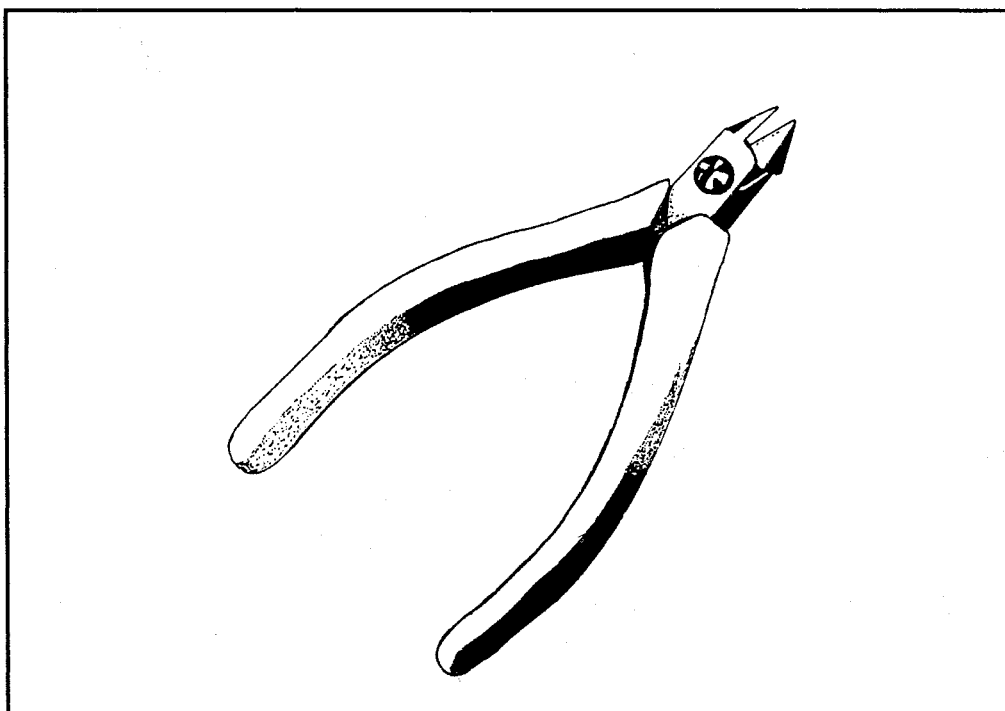
**Tools for Repair**

**Side Cutter**

The smallest is meant to handle component leads and other small wires such as those used for wire-wrapping. Most often these are side cutters, as seen in Figure 1.

**Oblique-, End-Cutter**

The oblique-, end-cutter, (Figure 2) is used to clip component leads and tails from the back of a PC board. Although it is not an essential tool (many technicians use the standard end cutter), it is useful to have.



**Figure 1:** Side cutters for component leads and small wires

**Multiwire Cutter**

The third type of wire cutter cuts larger cables, including mains, multiwire and other cable assemblies that are physically larger. The exact size and type needed depends mostly on what is being cut.

Other kinds of cutters and nibblers may also be needed. A ribbon cable cutter, for example, is designed to cut small wires which are spread out laterally. Shears might be needed to cut sheet metal.

Nibblers can do a similar job when you need to cut small portions without bending or kinking the metal. These cutters are added to the tool kit as the need arises.

4/1

Tools for Repair

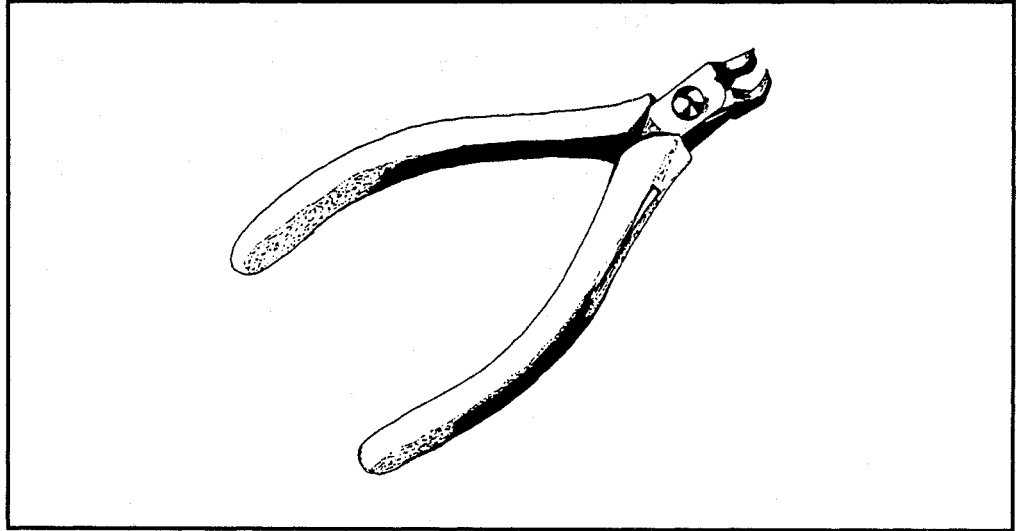


Figure 2: Oblique cutter

### Gripping Tools

#### Pliers

Gripping tools, such as pliers, are extremely useful. They can be used to grip wires, components, screws and just about anything else. Some can also be used to preform component leads prior to insertion and soldering.

#### Needlenose Pliers

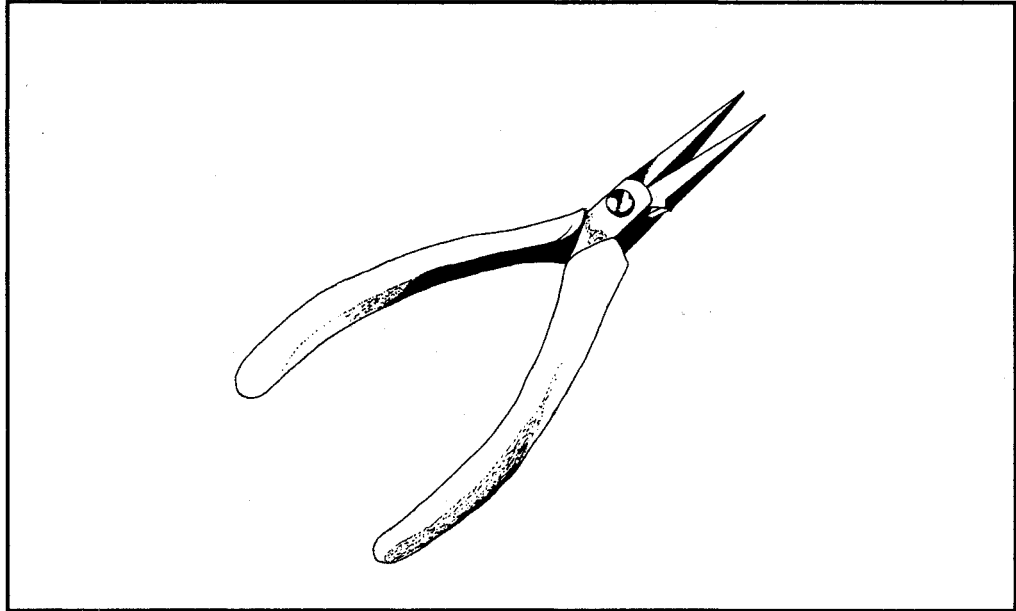
Needlenose pliers (Figure 3) are one of the most versatile in electronics. The long, narrow jaws make it easier to reach into tight quarters, and to grip small parts. The rounded backs of the jaws are often useful for making graceful bends.

The jaws are usually toothed to provide better gripping. Also available are pliers with smooth jaws, and even models that have plasticized jaws, or jaws with plastic sleeves. The latter are used when gripping delicate parts where jaw teeth could cause damage.

#### Tip

Standard pliers can come in handy now and then. The greatest caution is to be sure that you do not use it in place of a wrench or socket. This is not what the tool was meant to do. Another caution is to avoid those pliers which have bare metal handles. These are fine for general household use but are not suitable for use around anything electrical.

Combination pliers/cutters are also common. Most needlenose pliers, for example, have a wire cutter. The variety is extensive. Your purchase depends on



**Figure 3:** Needle-nose pliers

your specific needs. Keep in mind that the cutters on these combination tools are meant for general use. If you need to clip component leads close to a circuit board, use the side cutting tool (as shown in Figure 1).

### Other Gripping Tools

#### Small Gripping Tools

There are many times when needle-nose pliers will be too large for the job at hand. You may need to grasp something small, or may need to clip or clamp.

The obvious small gripping tool is a pair of regular tweezers. Keep in mind that the handle is almost invariably metal, which means that this is NOT a suitable gripping tool to use when power is flowing.

#### Surgical Clamps/Hemostats

Surgical clamps and hemostats are handy for holding small parts and for use as temporary heat sinks during soldering. These tools come in so handy that you can often find them at electronics supply houses and even at hobby stores.

#### “Helping Hand”

Another kind of gripping tool is the “helping hand.” This tool comes in a variety of configurations. The simplest has alligator clips (for holding wires) on the ends of an arm. Others have clamps designed to hold circuit boards. Still others can be used for different functions, adaptable to the situation.

## Wire Stripping Tools

### Knife

Many technicians use a sharp knife for wire stripping. While this works—and is sometimes the only solution under the circumstances—it is far better to use a tool meant for the job. There are two main reasons. One is the obvious danger involved, made worse because it's often necessary to use your thumb behind the wire while stripping the insulation with a knife. The other is that it's very easy to cut or nick the conductor. If this happens, the best you can expect is a weak connection.

### Tip

For these reasons it's best to use a wire stripping tool. As always the one used must be meant for that particular kind of wire. In essence, the tool will slice through the insulation without touching the conducting wire itself.

Some stripping tools have a number of blades, each with a different sized hole. These tools are sometimes awkward to use but are much more handy than having a drawer full of strippers for every wire size.

### Automatic Stripping Tool

A variation of this is the automatic stripping tool. These can be adjusted across a range of cutting depths and widths so that the tool can be used for different wire sizes.

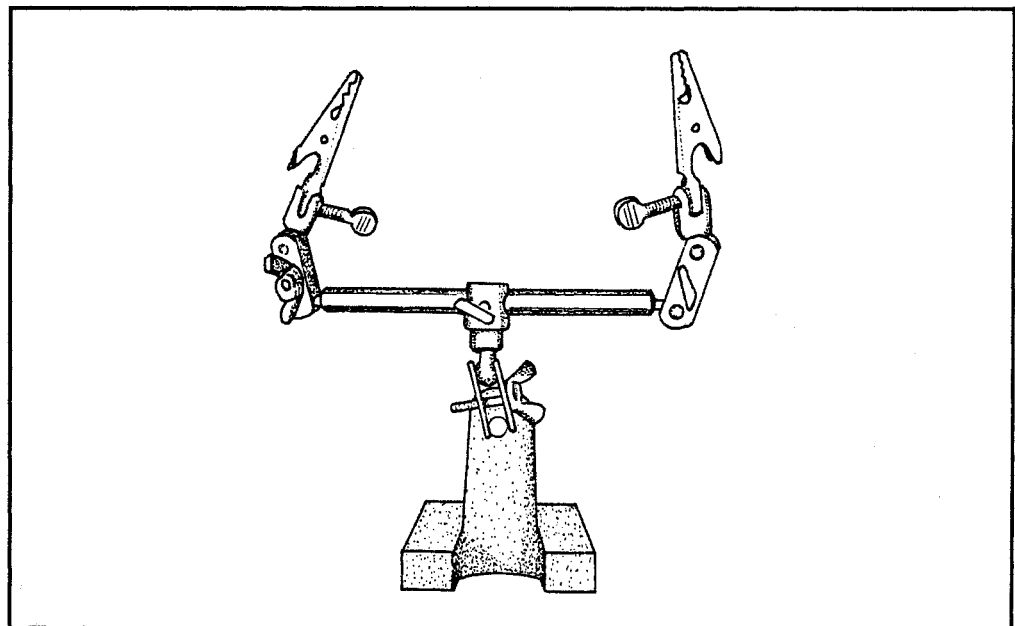


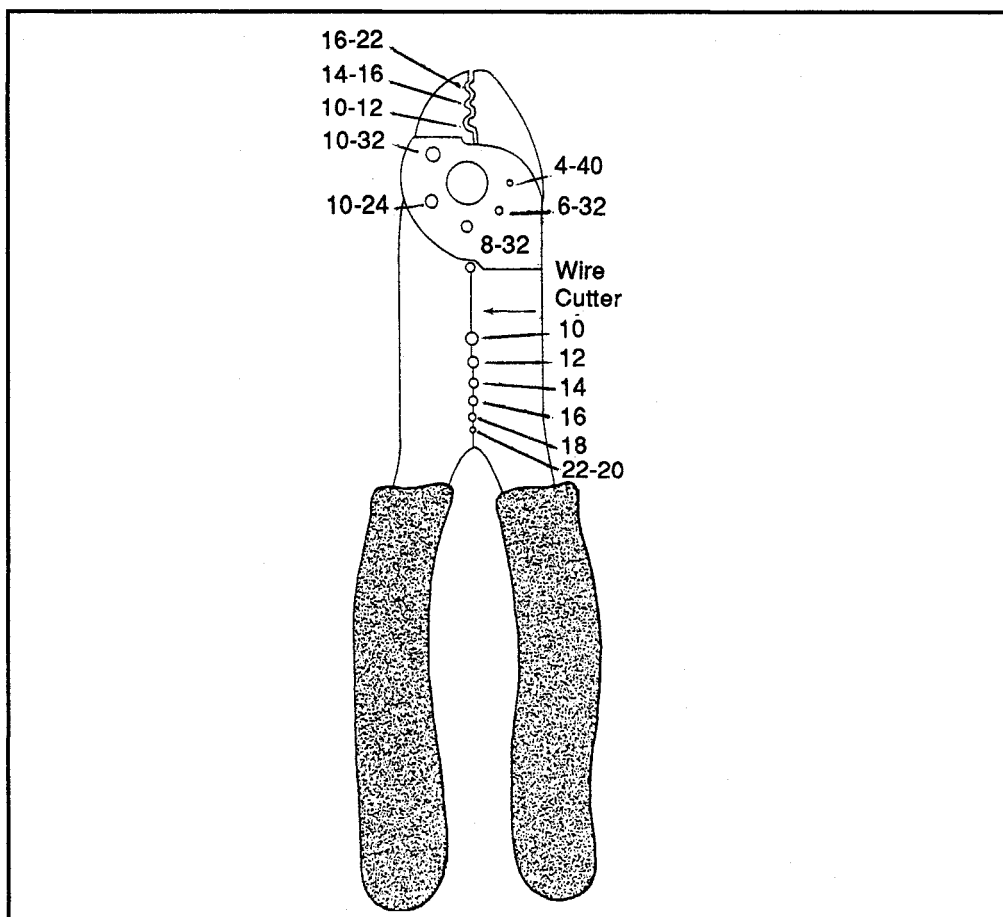
Figure 4: "Helping hand"

## 4/1

## Tools for Repair

**Ribbon Cable Strippers**

Also available are ribbon cable strippers (which have multiple blades) and cable strippers (which cut through to the center conductor). In each case the tool must match the specific ribbon or cable. You cannot use a stripper meant for R-8 cable on R-59 cable and vice versa.



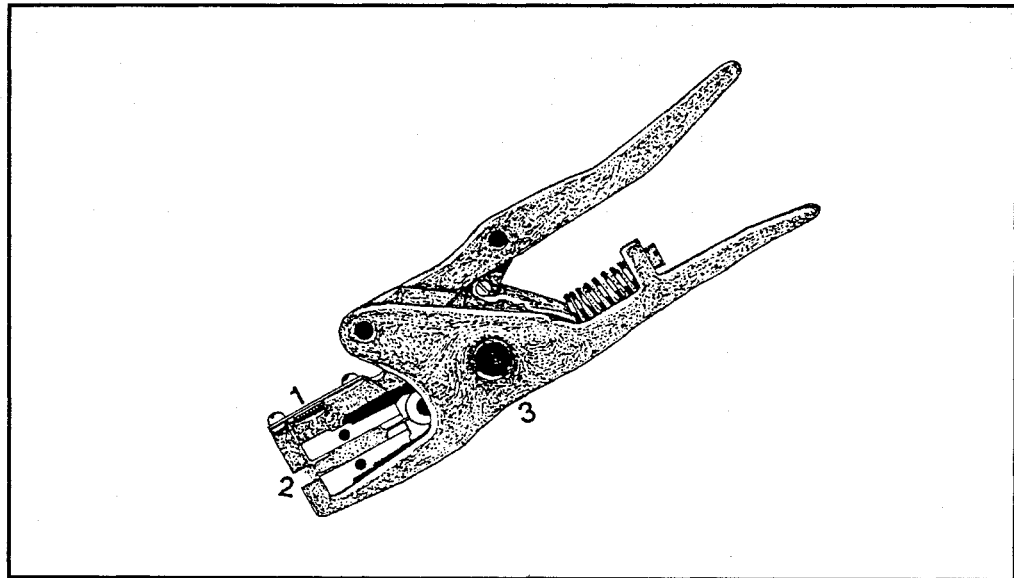
**Figure 5:** This wire stripper is suitable for removing the insulation from many different wire sizes

**Crimping Tools****Basic Types**

The three basic types of connection are:

- wire wrap
- soldered terminal
- crimped



**4/1**  
Tools for Repair

**Figure 6:** Automatic wire strippers 1) adjustment screw, 2) stripping blade, 3) wire cutter

The wire-wrap technique is used most often to make a connection on a prototype board to test a new or modified electronic circuit. Soldered terminals are common in direct “hard-wired” connections, and are also used to attach many different kinds of connectors to the wire or cable. When done correctly, soldering makes a strong connection, both physically and electrically.

Crimped connections make use of a solderless (or partially solderless) connector. Since there is no solder (or little solder), the strength of the connection is handled physically, either by having the connector clamped directly onto the wire or by using a crimped retaining ring. One of the most common uses of crimps is with the solderless F-type connector on R-59 cable for television hookups.

**Tip**

Some technicians make the mistake of using the wrong tool for the job. For example, some will use pliers to crush the connector. Although this will often work, it will just as often make an unsightly and even weak connection. Not only do you need to use the right crimping tool, you must use it correctly. In general this means:

- The insulation must be stripped away so that the conductor protrudes just slightly at the end, with the actual length being determined by the type of connector used;
- The conductor is inserted into the connector or receptacle;
- The crimping tool is closed completely to make a secure crimp.

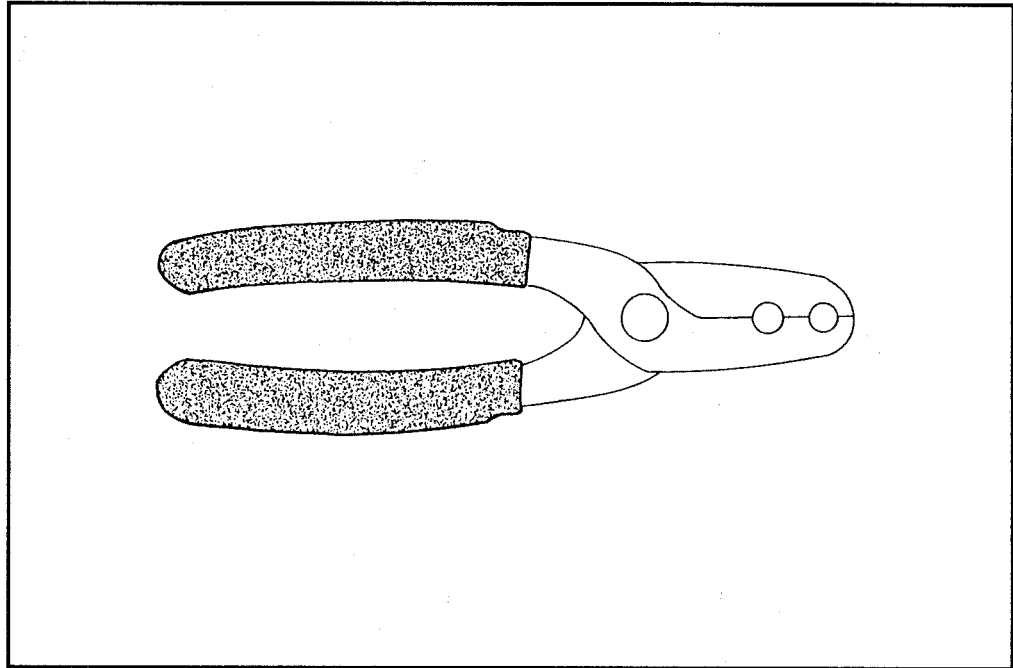


Figure 7: Cable crimping tool

Some of the more expensive tools have features that force you to close the jaws completely, and thus complete the crimping action, before you can open them again. With the more usual type, you'll have to be certain that crimp is complete and secure.

### Screwdrivers and Nut Drivers

The range of screwdrivers and nut drivers manufactured today is impressive, and sometimes confusing. Some devices will have standard screws and nuts, others will have metric—a few may even have a mixture of both.

#### Minimum Equipment

At a bare minimum you should have two blade screwdrivers and two Philips head—a medium and small of each (See Figure 8). Add more later, as the need arises. It is important that the head of the screwdriver fits exactly into the head of the screw. If it doesn't, you risk damaging the screw, the screwdriver, and possibly yourself.

#### Jeweler's Screwdrivers

As shown in Figure 9, a set of jeweler's (watchmaker's) screwdrivers can also come in handy. Normally these are purchased as a box set, containing 5, 6, or more screwdrivers with heads of different sizes. Often the set will include both the blade and Philips types.

4/1

Tools for Repair

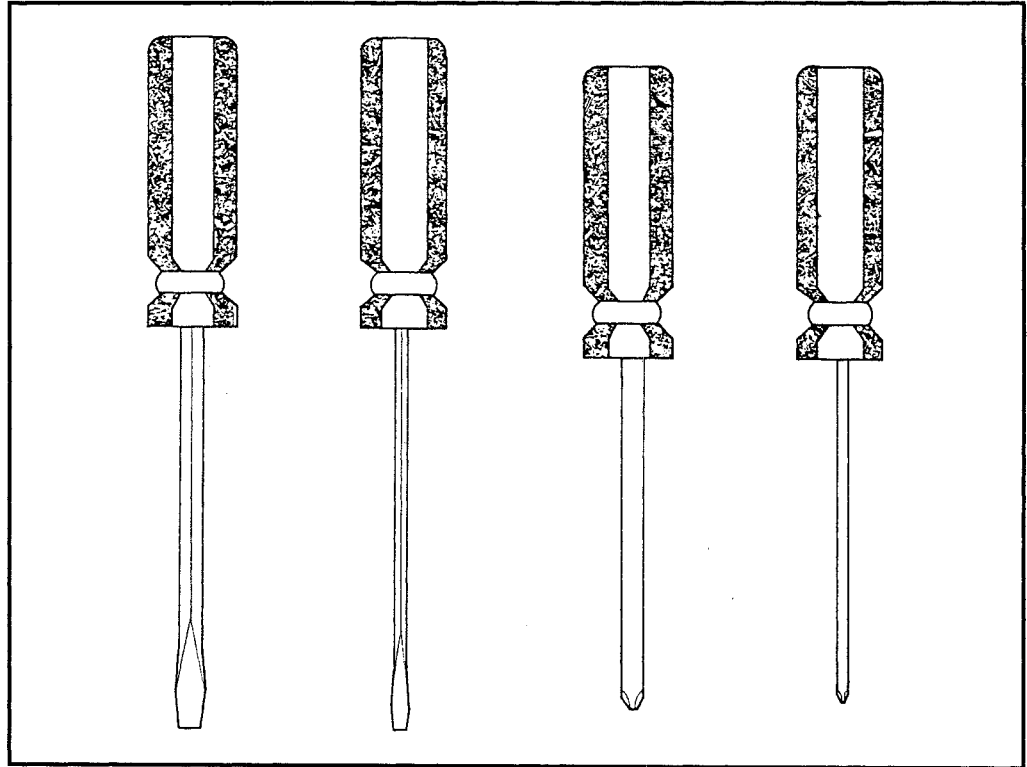


Figure 8: Standard screwdrivers

**Regular/Magnetic/  
Gripping**

Screwdrivers can be regular, magnetic or gripping. The first is for general use. The latter two come in handy when trying to remove or insert a screw in tight quarters. Care must be taken with the magnetic type, however. Although the magnetic field is very small, some components cannot tolerate any magnetism near them.

**Torx Head**

Occasionally you will come across a different kind of screw head. The Torx head is becoming popular. In theory, the Philips head is less prone to stripping than the slotted type head—and in theory the Torx head is less prone to stripping than the Philips head.

**Special Security  
Head**

In addition, you may occasionally find a screw with a special security head. These are designed specifically to keep people (including technicians) out.

**Nut Drivers**

Nut drivers are like wrench sockets mounted to screwdriver handles. Like regular sockets, the socket-ends of the nut driver come in a variety of sizes, and may be either standard or metric.

4/1

Tools for Repair



Figure 9: Jeweler's screwdrivers

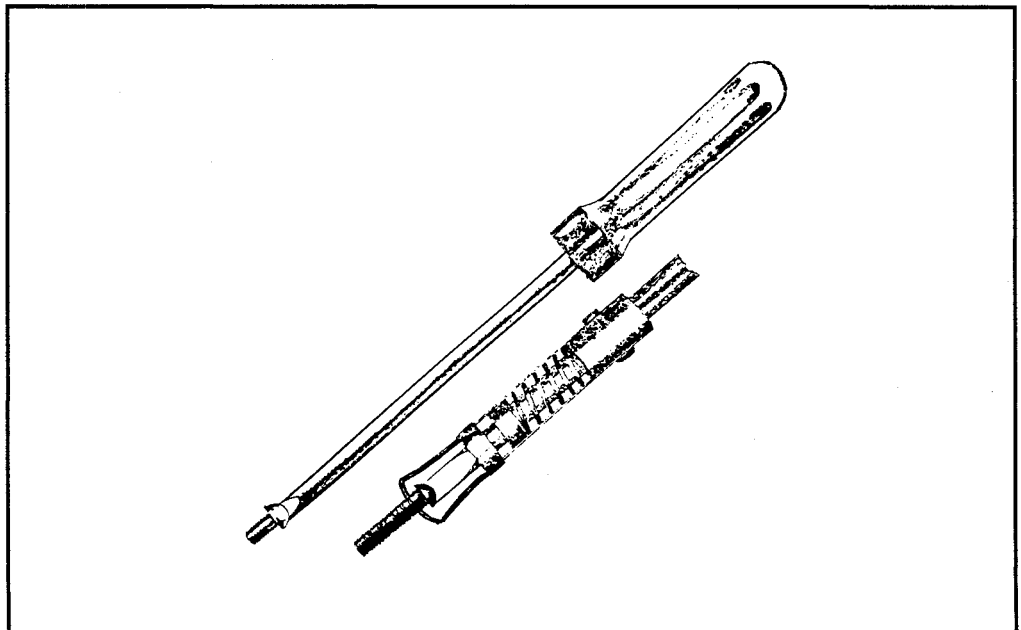


Figure 10: Gripping screwdriver

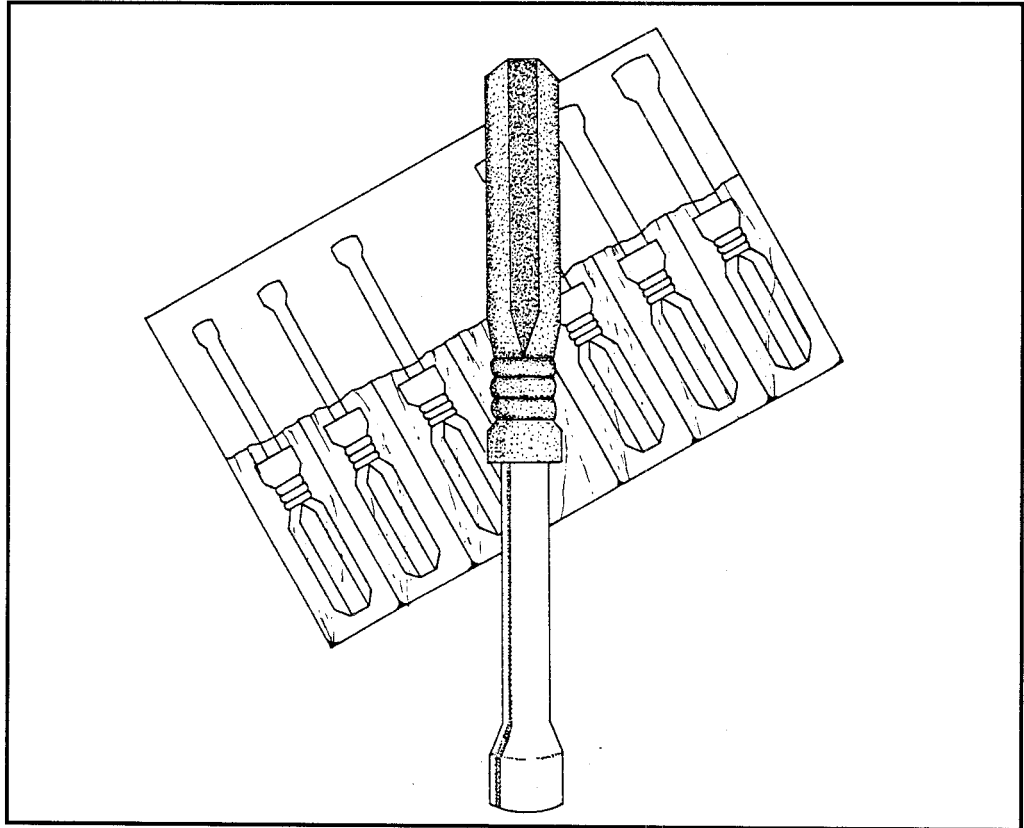


Figure 11: Nut driver set

You have a choice of a fixed set of sockets with the socket a physical part of the tool, or of a set with interchangeable socket ends. The interchangeable set will usually allow you to use regular sockets (generally those with a 1/4" socket mounting hole).

### IC Tools

#### Installer/Puller/ Straightener

If you intend to be working with ICs—and these days there isn't much choice—you should have at least one IC installer and one IC puller. You may wish to purchase an IC pin straightener. This latter tool gently and safely straightens all the pins, which is a much better choice than trying to do this by hand with something like needlenose pliers.

### Inspection Tools

The electronics technician has three built-in inspection tools—nose, eyes and

4/1

Tools for Repair

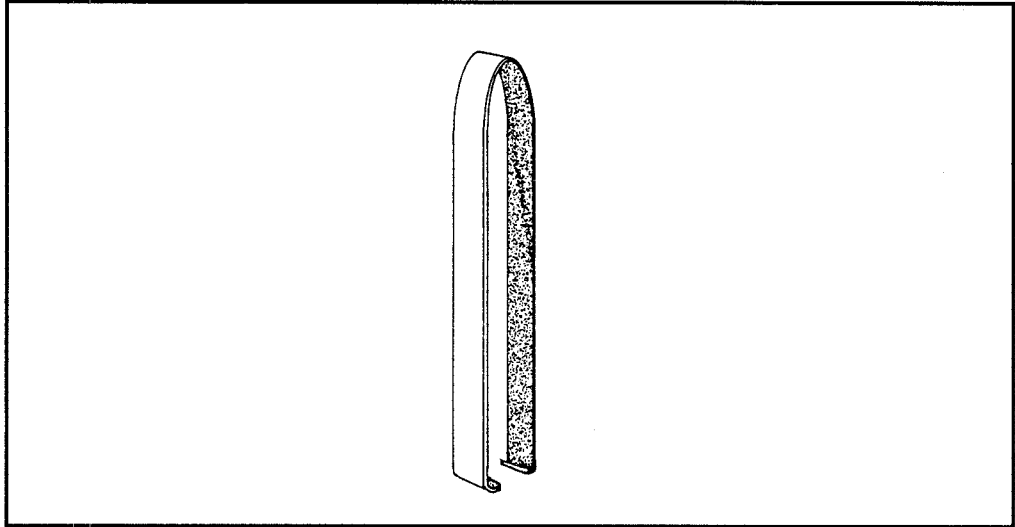


Figure 12: IC puller

ears. Other inspection tools are available to make better use of the natural senses, particularly the sense of sight and hearing.

Burned resistors and other components can often be seen and even smelled. Other components that are failing may give off characteristic noises. (Some capacitors, for example, will whistle if they are failing. A variety of mechanisms will also make noises.)

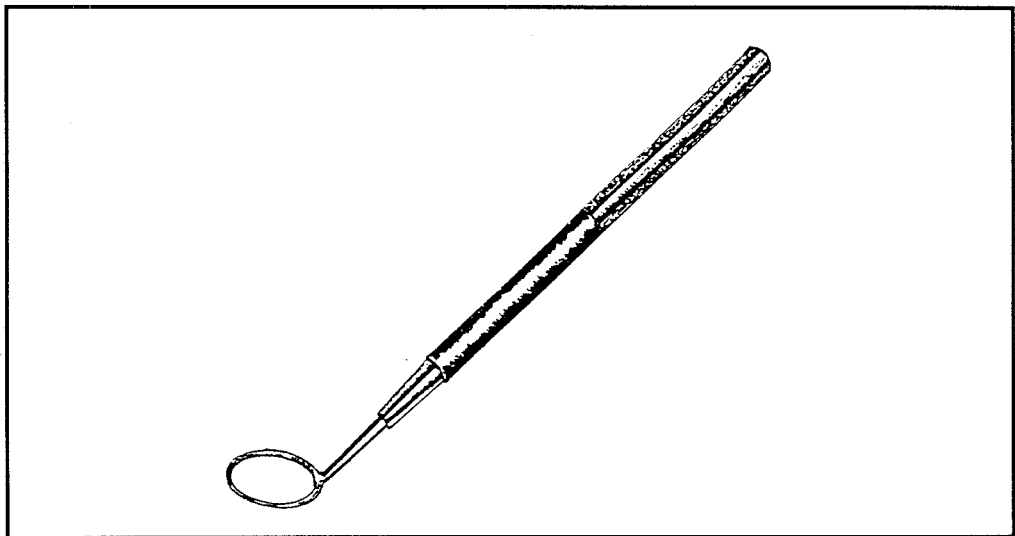


Figure 13: Inspection mirror

**4/1**

**Tools for Repair**

**Stethoscope**

A stethoscope can help you locate certain noises. A particular sound may, to your ear, seem to be coming from everywhere. The stethoscope can help pinpoint the source, or will at least narrow it.

**Bench Lamp**

For sight, the most basic inspection tool is a good source of light. This is often an adjustable bench lamp, but your tool kit should also include a flashlight and some spare batteries.

**Mirror**

At times, regardless of the amount of light, you will discover some places are inaccessible. At such times a mirror with a handle, such as a dental inspection mirror, will come in handy. It can be inserted into areas where you can't normally see, and is particularly helpful when you need to see the back of something that is hidden.

**Magnifying Glass**

You will need a magnifying glass to examine small parts, markings and codings. There will also be times when you need to have a close-up view of a connector, solder trace or other component or feature. At such times a decent magnifying glass can be invaluable. Because clear vision is so important, get a magnifier with good quality optical glass. A magnifier that distorts is not only less useful but could actually be detrimental.

**Soldering**

Another part of your basic tool kit is the soldering tool. This can be either one of the least expensive parts of the tool kit, or one of the most expensive.

**Soldering Pencil**

For most soldering a simple soldering pencil in the range of 15-40 watts will do. These can be purchased for as little as a few dollars. Others, with interchangeable tips and wattages will cost a little more.

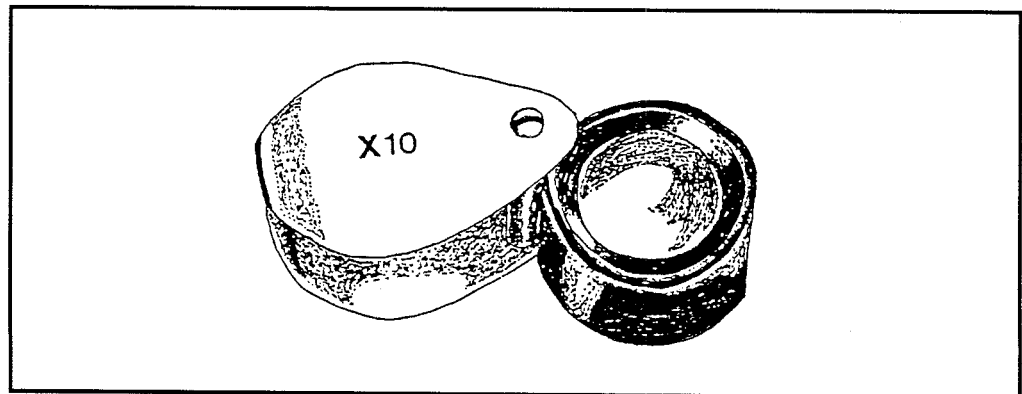
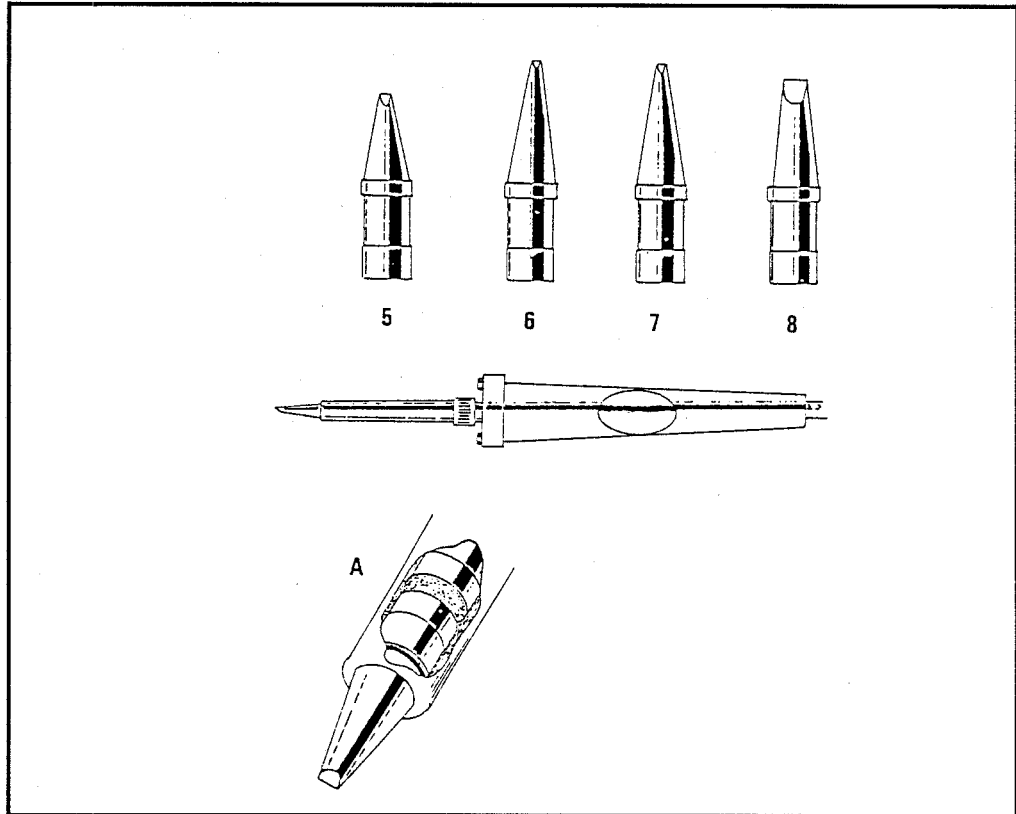


Figure 14: Magnifying glass

## 4/1

## Tools for Repair



**Figure 15:** Interchangeable tips and temperature control can be critical

Not that long ago these soldering pencils were quite suitable for virtually every job. Although they are still “stock and standard” in the field, they are inappropriate for many modern circuits and components.

### Soldering Tool with Grounded Bit

Certain components, especially ICs, are highly sensitive to both heat and static electricity. Care is needed to control the first and to eliminate the second. If you intend to work on such circuits, you will need a soldering tool that has a grounded bit to keep any stray static electricity from going where it shouldn't. It is also often helpful to have variable control of the heat.

Such tools are fairly expensive, but when compared to the cost of ruining a circuit, they are relatively cheap.

### Tip

In general, if you intend to do much soldering or desoldering, make the investment in a good tool. The \$3 soldering pencil might be fine for soldering wires, but can cause expensive damage if used on a delicate circuit.



**4/1**

**Tools for Repair**

Regardless of the tool you purchase, be sure that it has a holder. This is usually a metal spiral stand that holds the tool at an angle, and keeps it away from any surface, while also creating a barrier against accidentally touching the hot tip.

The solder used **MUST** be suitable for electronics. Solder for plumbing often uses an acid core as a flux. This is unsuitable for electronics work. It can damage component leads and will almost certainly add stray capacitance.

**Resin Core Solder**

Resin (or rosin) core solder is used for electronics. This can be found in both wire and strip form. It is most often found in spools. The size will vary considerably. For most uses you will want the smaller wire sizes since they melt faster and thus reduce the possibility of heat damage to the circuit or component being soldered.

**Desoldering**

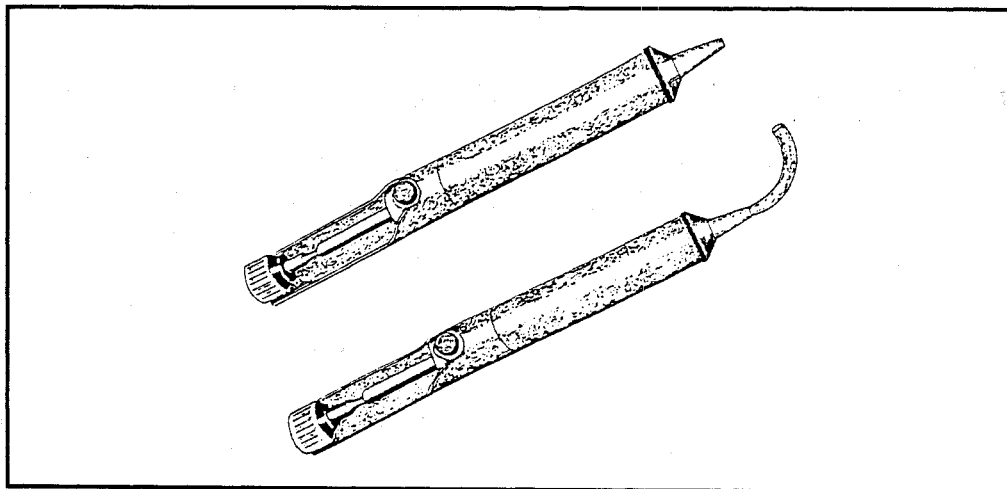
Just as you will need to solder, you will also need to desolder. This means you will be removing existing solder from a joint or component.

**Desoldering Wick**

One of the simplest ways is to use a desoldering wick. This is a resin-impregnated wire braid. The area to be desoldered is heated until the solder is melted. The braid is touched to the area, at which point it pulls the solder away from the area and into the braid. The used part is then clipped away and discarded.

**Desoldering Bulb**

A second method is to use a desoldering bulb. This tool is a simple syringe with a heat resistance nozzle (usually made of PTFE plastic). The bulb is squeezed,



**Figure 16:** Desoldering tool

**4/1**

**Tools for Repair**

forcing the air out of the bulb. The solder is then melted, and when the tip of the bulb is placed near the liquid solder and the bulb released, the solder is sucked through the nozzle and into the bulb.

**Spring-loaded  
Desoldering Tool**

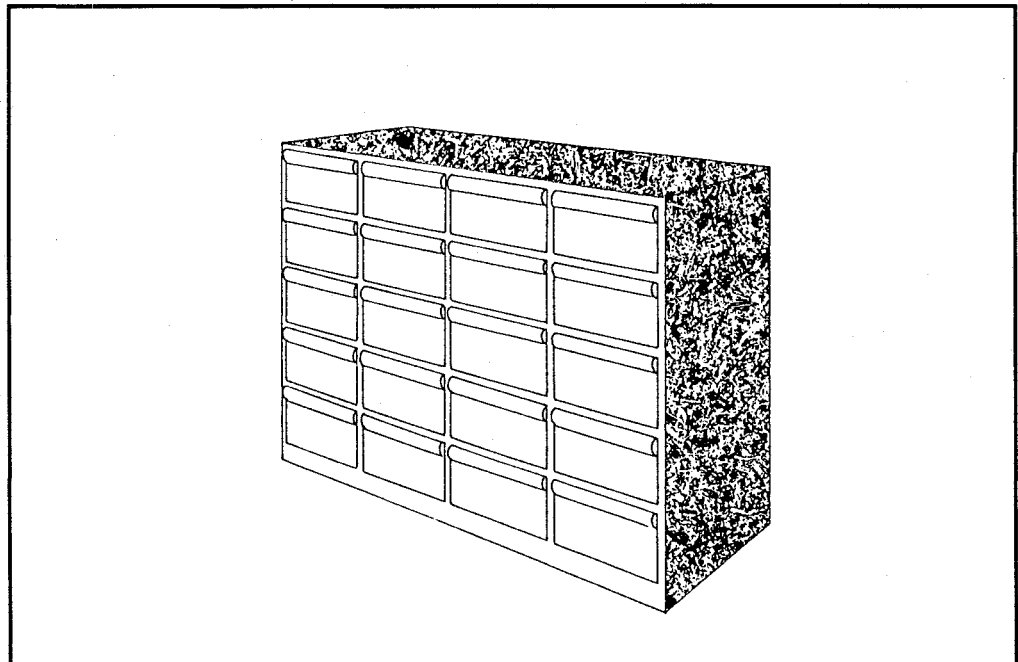
A little more expensive is the spring-loaded desoldering tool shown in Figure 16. A lever is depressed which moves and locks a plunger inside the tool. Again the solder is melted and the heat resistant tip is brought near the liquified solder. Then a button is pressed. This causes the plunger to snap back up inside the barrel, thus sucking in the melted solder.

**IC Desoldering Bit**

A more expensive tool, which is also available as an adaptor for some soldering irons, is an IC desoldering bit. This allows all the pins of a chip to be desoldered at the same time. The more expensive versions have built-in suction to remove the solder from the pins as the tool melts it.

**General Supplies**

A shop with every tool and piece of test gear will be almost useless without other supplies on hand. It will be impossible to carry every possible component, but you should have some of the common ones on hand at all times.



**Figure 17:** A multidrawer cabinet will help you find the part you need quickly

**4/1**

**Tools for Repair**

**Multidrawer Cabinets**

The first thing you'll need is a means of storing and sorting the parts. Merely tossing them into a box is almost as bad as having no spare parts at all. Multidrawer cabinets are easily obtained and are not expensive. The plastic kind, with clear drawers, allows you to see what is inside the drawer. Even then, clearly label each drawer.

You will almost certainly need more than one cabinet. You may even choose to have cabinets for each of the overall parts categories (resistors, capacitors, etc.), at least one for miscellaneous parts, and at least one for mechanical parts (screws, nuts, fasteners, etc.). How many cabinets you have, and what they'll contain, depends entirely on you.

**Standard Resistors**

You will almost certainly need a selection of standard resistors. This selection needs to be as wide in range as possible, as to value, power rating and other factors. Most can be carbon composition (since these are used most often) with a range of values between about 10  $\Omega$  and 1 M $\Omega$ . In general, avoid resistors with a tolerance of greater than 10%, and preferably most of your stock should be 5% tolerance or better. Remember, you can always install a better component.

The range of power ratings needed depends on the equipment with which you will be working. The most common is the 1/4 W resistor. However, there will be many times when 1/2 W or greater resistors will be needed.

**Capacitors**

Capacitors are more tricky. It's difficult to predict exactly which capacitors you will need, of which values and which types. Further complicating the assessment, some capacitors have a shelf-life, which decreases with adverse storage conditions.

**Solid State Components**

It is even more complicated to predetermine the solid state components, such as diodes, transistors and ICs. There are so many different kinds. Some are interchangeable under certain circumstances while others are meant for a specific purpose. This makes it almost impossible to have an effective stock on hand to cover all the different jobs (unless you care to invest thousands of dollars). You'll find, however, that as you work in your chosen field you'll notice certain trends that will make your decision easier. (This differs from field to field, so there are no general guidelines.)

**4/1**

**Tools for Repair**

---

---

---

---

## **4/2 Basic Test Equipment**

---

### **Introduction**

There was a time when only basic equipment was needed for troubleshooting and repair. As devices have become more complicated, so have the pieces of equipment needed to work on them. Before getting into the detailed descriptions, some practical advice concerning test equipment should be covered.

Your eyes, ears and brain are the best test equipment you can have. For most problems, use your senses to determine where to begin.

Ears work well for identifying the problem. Devices often make noises while in operation. Often you can hear if something is wrong, and where. A motor that is whining or grinding, a gear that clacks, or a capacitor that is whistling are all examples of problem noises. In audio repair you must hear the output to decide if a piece of equipment is working properly. (Keep in mind that even if you adjust all settings to the manufacturer's specifications, the end-user must be satisfied with the operation.)

For example, an individual was having problems with a Hi-Fi VCR which played the left channel audio at a level higher than the right channel audio. The right channel audio fluctuated from loud to soft, making the audio annoying and undesirable to hear. He listened to the VCR and decided to clean it. He then listened again, to find out if this was the solution. The problem persisted, so he checked the audio board. He replaced the board and realigned the unit.

Eyes are the best way to locate most problems. If a power circuit has failed, look to see if there are any indications. Burn marks, blown fuses, leaking capacitors, and broken wires are just a few examples of things you might spot upon visual examination. In a more extreme example, a piece of mainframe computer equipment was sent back to the factory because it wouldn't come on. Upon opening the power section, the scorched remains of a mouse were discovered. It had apparently crawled into the unit and stepped across two points carrying several thousand volts. The remains were removed, and the section replaced.

Your brain is a marvelous computer of complex neurons and synapses. Stored within the many cells is the practical knowledge required to make the correct,

## 4/2

## Basic Test Equipment

decisions for repairing items. Think problems through thoroughly and logically, but keep in mind that sometimes the solution may defy logic.

The design of most equipment these days is moving toward smaller electronic parts. These parts are becoming harder (and sometimes impossible) to troubleshoot on an individual basis. This is due, in part, to the number of functions an individual Integrated Circuit (IC) can perform. With the surface mounting of ICs and the miniaturization of other components, more advanced test equipment is required. This section describes the test equipment required for electronics repair.

## Test Equipment

### Work Station Supply

The workstation power supply is usually a variable VDC, with sometimes variable VAC outputs. It can be a lab-grade variable voltage supply or a well-filtered, high-current supply. Usually it is best to have both with voltages from a few volts to a few thousand. Figure 1 shows a typical workbench power supply. A voltage divider may be required for units that have several different power inputs. A typical voltage divider that you can build is shown in Figure 2.

The power supply can be very useful in place of items that require the use of

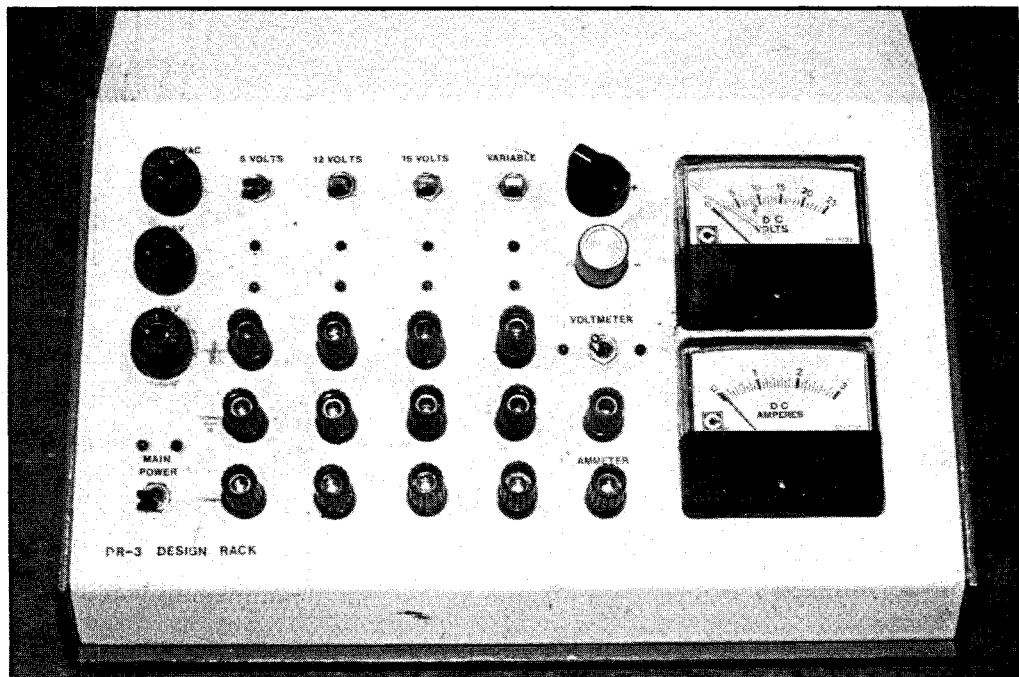


Figure 1: Typical workbench power supply

4/2

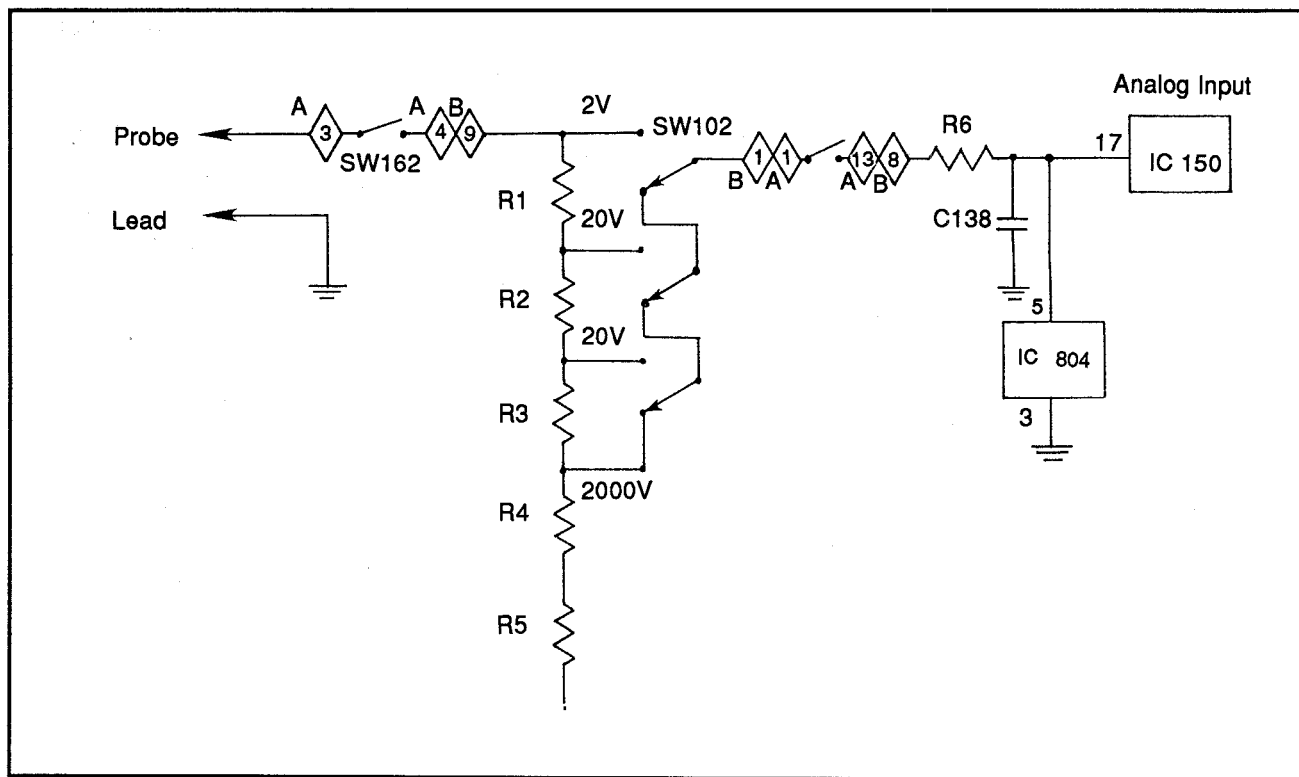
Basic Test  
Equipment

Figure 2: A voltage divider

batteries. Also, it is best to use the workbench power supply, rather than the tested item's power section, to avoid damaging the unit. When testing, remove or bypass the internal power supply.

When testing troubles in output stages of stereo amplifiers, the DC power supply can be used. The current limits would be set to the level for the amplifier stage requirements, thereby avoiding possible damage to expensive transistors.

### Capacitance Checkers/ Substitution Box

A capacitance checker simply measures the capacitance of a capacitor. The test leads are hooked to the capacitor with respect to polarity (if any) and the scale of the meter is read. The range selector is set for the step higher than the suspected capacitance. If the reading is within a marginal error of perhaps 10 percent, the capacitor can be assumed to be good.

Some digital volt/ohm meters have capacitance checkers where you plug a capacitor into slots and read the meter. These digital multimeters (DMMs) have multiple ranges for checking capacitors. You can attach test leads from these slots and test capacitors in circuits.

4/2

Basic Test Equipment



Figure 3: A capacitance checker

Capacitors suspected of leaking can be tested by an ohmmeter. The resistance of a capacitor should be in the several  $M\Omega$  range.

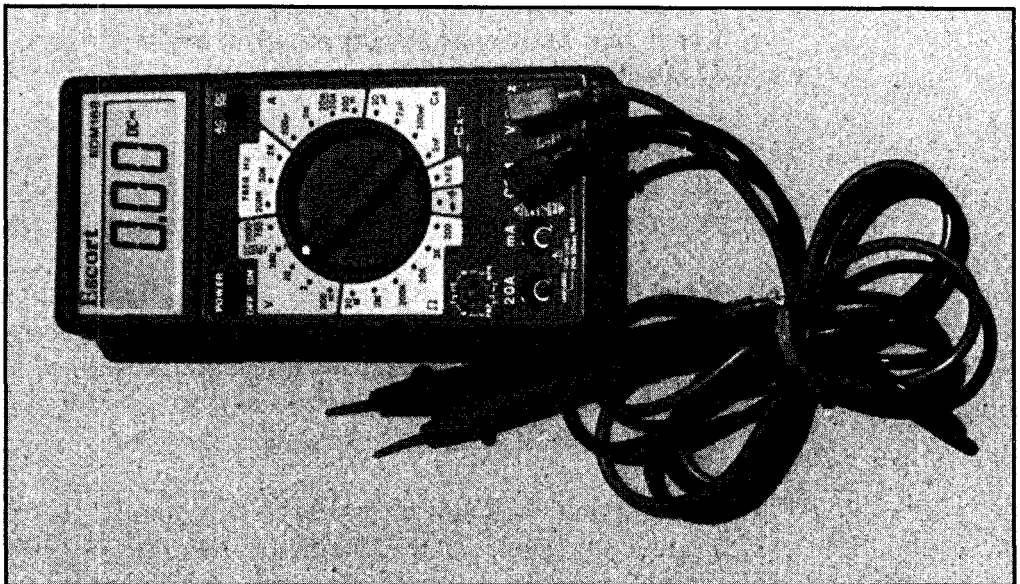


Figure 4: Digital multimeters (DMMs) with slots to test capacitance



**4/2**  
Basic Test  
Equipment

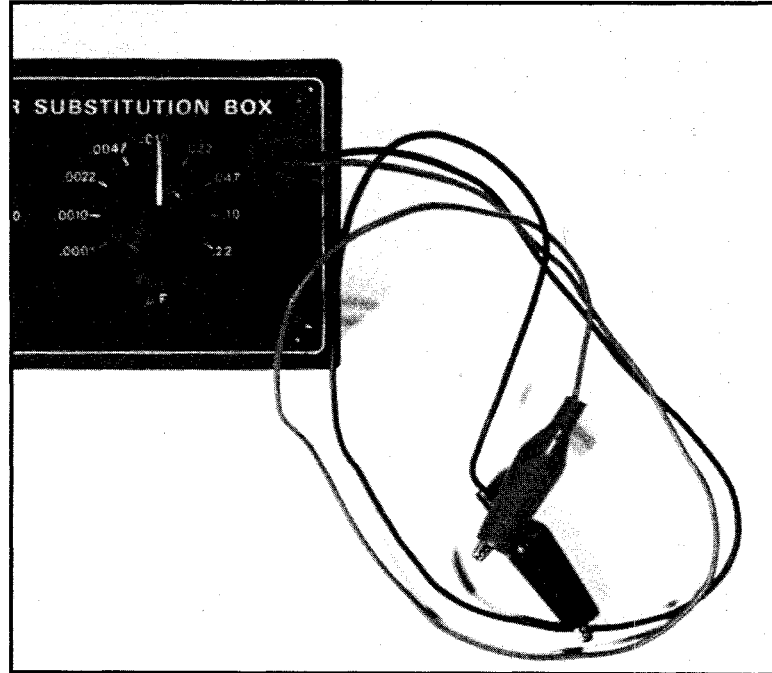


Figure 5: A capacitance substitution box

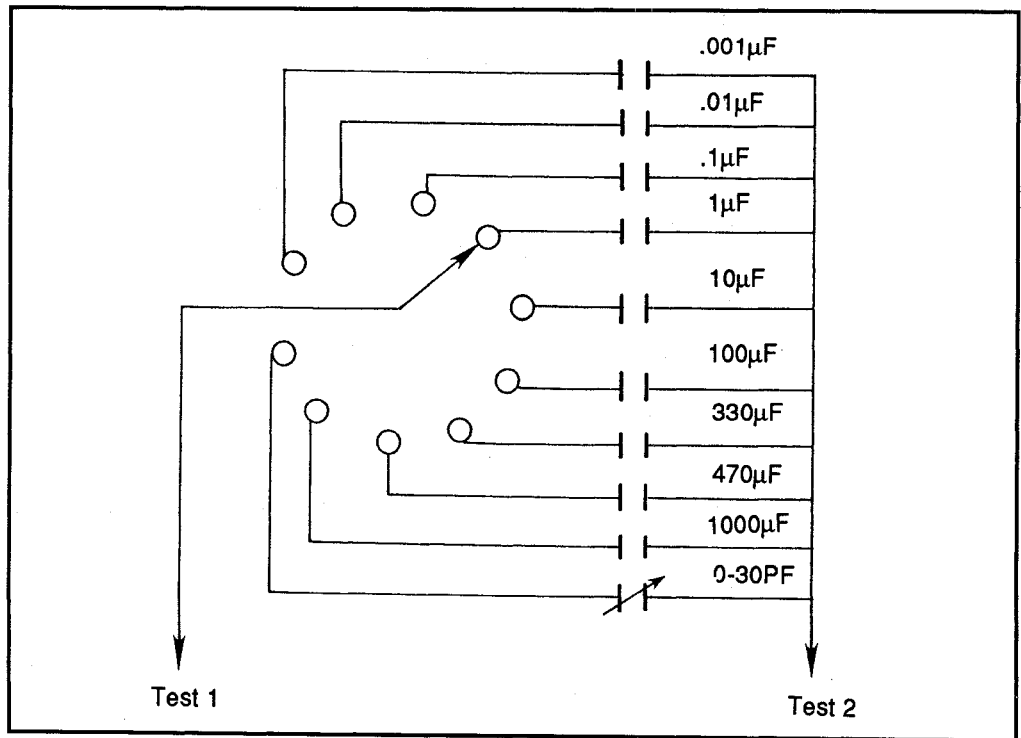


Figure 6: Capacitance substitution circuit

**4/2****Basic Test Equipment**

When connected, the initial reading will appear low and progress to an almost infinite reading. Smaller value capacitors may charge faster, displaying an infinite reading almost immediately.

**Capacitance Substitution Box**

A capacitance substitution box is shown in Figure 5. This is a variety of capacitors built into a casing, hooked to a rotary switch with a common output.

The use of such a simple device can determine either the replacement, or proper capacitance needed for a circuit being tested. Capacitance substitution boxes are easily built. Figure 6 shows a sample circuit.

**Resistance Substitution Box**

A resistance substitution box is shown in Figure 7. Some resistance substitution boxes may be piggybacked with capacitance substitution boxes as shown in

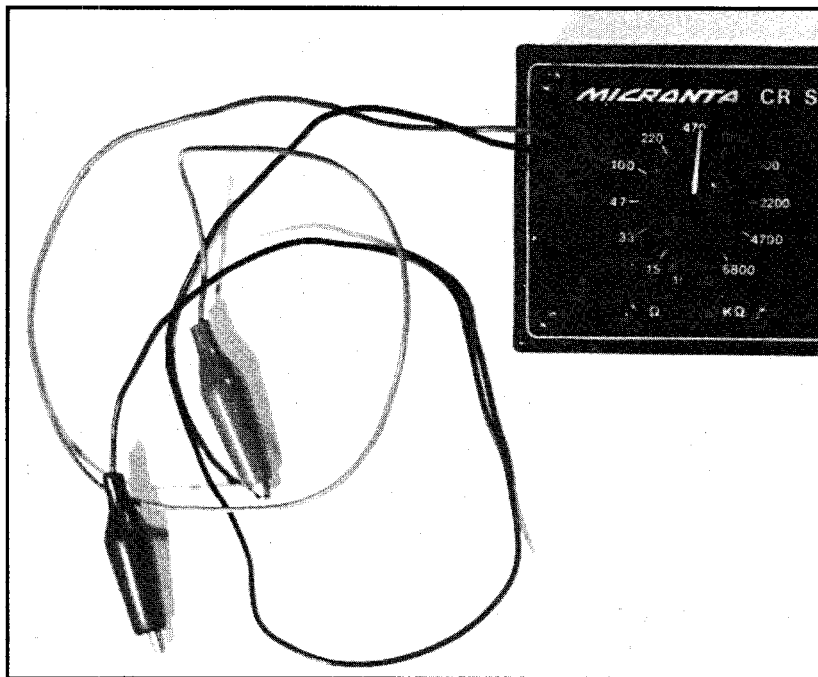


Figure 7: Resistance substitution box

Figure 5. Fixed resistance values are selected via the rotary switch. A circuit diagram of a resistance substitution box is shown in Figure 8.

**Signal Tracers**

A signal tracer is a simple electronic device which may consist of aural (speaker) and visual (meter) signal monitoring sections. The signal tracer traces an RF signal through various stages of a receiver.

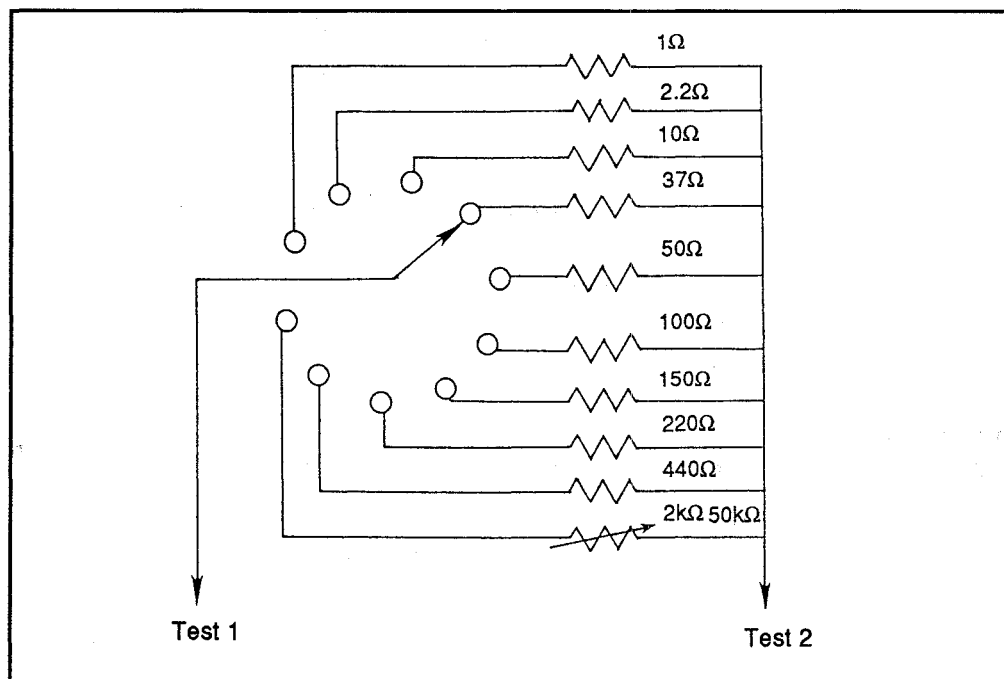


Figure 8: Resistance substitution circuit

The signal tracer is connected to the input section first, then the output section of each stage in the signal path. The trouble can be found in the stage where the signal disappears.

Figure 9 shows a simple signal tracer. The selector switch is set to the RF position and an RF detector probe is used to check for the signal. The ground lead of the RF probe is connected to the chassis ground. The probe tip is connected to the antenna terminals. The gain control of the tracer is turned up until you get a signal level indication.

The test probe is then moved along the signal path from the base to the collector of the RF stage. Next, connect the test probe to the base of the mixer stage and to the collector.

Slowly work through the input and output of each IF stage to the detector. As you move through the receiver, the signal from the tracer should increase, and the gain will have to be cut back.

Over time you will obtain a feel for what is the proper gain for a particular stage. The gain control is adjusted so as to produce a constant reading on the meter from one circuit to the next.

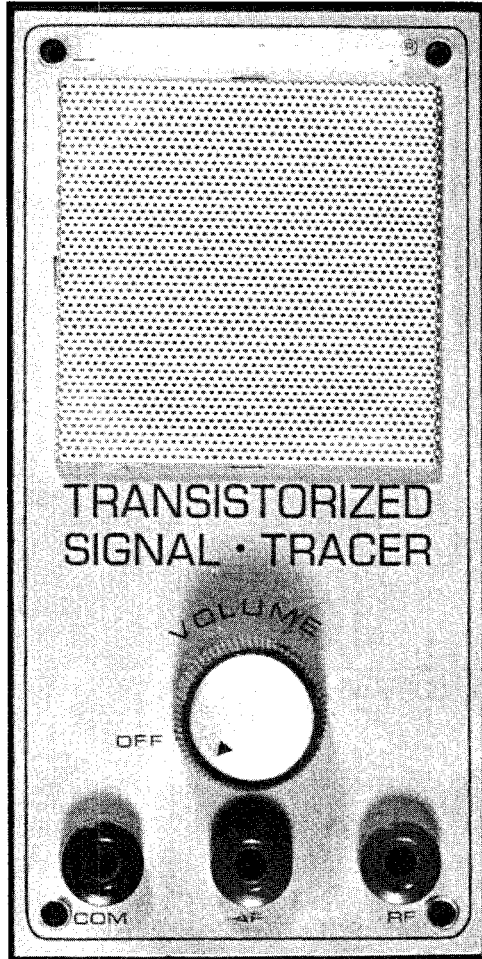


Figure 9: Signal tracer

### Transistor Checkers

A transistor checker is shown in Figure 10. It can be used to check low-, medium- and high-powered PNP and NPN transistors. The transistor checker can check for electrode open circuits, current gain, short circuits and visual indications of signal output information. A typical transistor checker should be able to test all transistor types (FET, N or P) and all power ratings with the same test.

Modern transistor checking can usually be done with multimeter checkers. Refer to the DMM's manual. Typically there will be an hFE socket (Figure 11) with several slots labelled E, C, B in which a transistor is inserted. Then the transistor reading is displayed on the meter.

Transistor checking is usually a "Go/NoGo" form of troubleshooting. A transistor checker can be used to determine the polarity of an unknown transistor

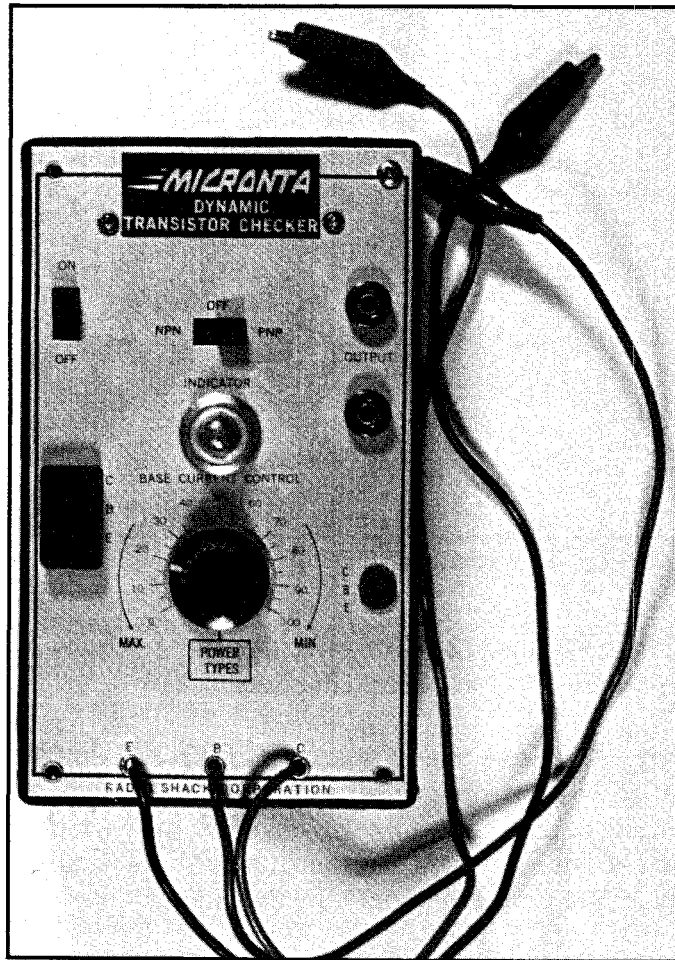
**4/2**  
Basic Test  
Equipment

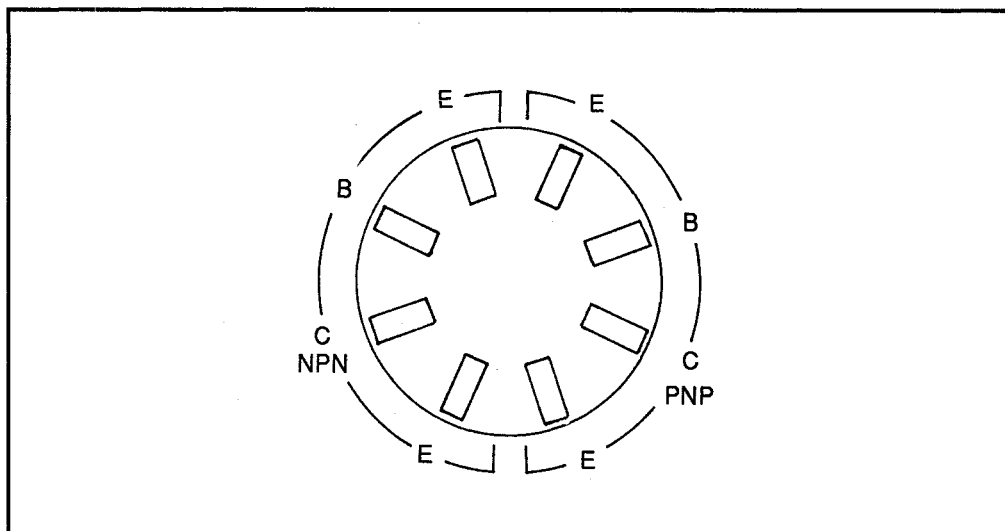
Figure 10: A transistor checker

and the operating current. This is very useful when trying to match a new transistor to an unknown old one.

The transistor checker may have a lamp that glows when a transistor is connected and the unit is adjusted correctly. The brightness of the lamp varies in direct proportion to the signal output. The greater the output, the brighter the lamp.

Other units may have some kind of analog or digital meter to display the statistics for the transistor.

The transistor checker can be used on transistors alone, or in a circuit. Test leads are provided for connecting the unit to a transistor within a circuit. The leads, as well as the test sockets, are labeled as to the emitter, collector, and base of



**Figure 11:** Test socket configuration

transistors. Figure 12 shows typical designs of transistors and which leads are designated collector, emitter and base.

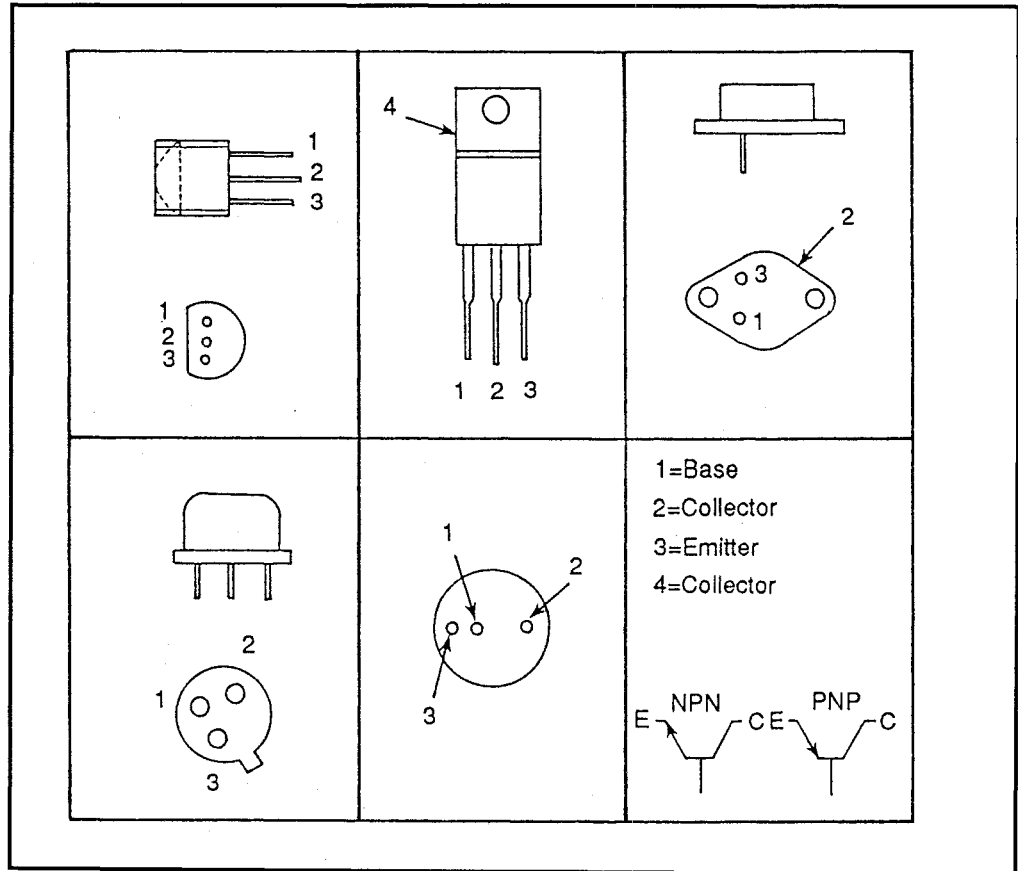
Testing transistors with a transistor checker is simple and straightforward. A stand-alone transistor is inserted in the proper holes, or connected to the proper test leads of the checker. In this example, the current control knob is placed at zero. The lamp is switched on and the correct selection of the PNP/NPN switch is made. Transistors will only fire the indicator lamp when the switch setting is correct.

Slowly rotate the current control knob and note the point at which the lamp glows and then drops out. This indicates the operating current of the transistor. The higher the value, the greater the gain since the base current is decreased as the knob is rotated towards 100. Maximum base and collector currents occur at zero.

If the indicator lamp does not operate, either the transistor is bad, the settings are incorrect, or the transistor specifications fall outside the parameters of the tester.

Checking transistors in a circuit depends on the shunting resistances of the circuit in which the transistor is used. If the transistor shows an adequate gain in a circuit, it can generally be considered good. If no gain, the problem could be a bad transistor. If, for example, a circuit should have a gain of 10 but shows no gain, or improper gain, the transistor should be removed and rechecked out of circuit. Checking for leaky transistors must always be done out of circuit.

## 4/2

Basic Test  
Equipment

**Figure 12:** Some typical transistor designs and configurations

### Tube Testers

Tube testers have almost become passé, however, there are still a number of devices—particularly older ones—that use tubes. It may be a good idea to have a portable tube tester, or access to one at your local parts supplier.

Tube testers have an extremely simple design. Figure 13 shows a typical home tube tester.

To test a tube, find the proper socket on the tester, insert the tube, look up the tube on the tube chart and set the dials. The unit will indicate whether the tube is good or bad, and with the press of a button, you can determine if there is a gas leak.

By looking at a tube you can usually see a visible indication of a gas leak. There is a silver lining on the top portion of the tube that extends down the sides about 1/4 of an inch. If this is missing, or only a small amount remains, you can assume

## 4/2

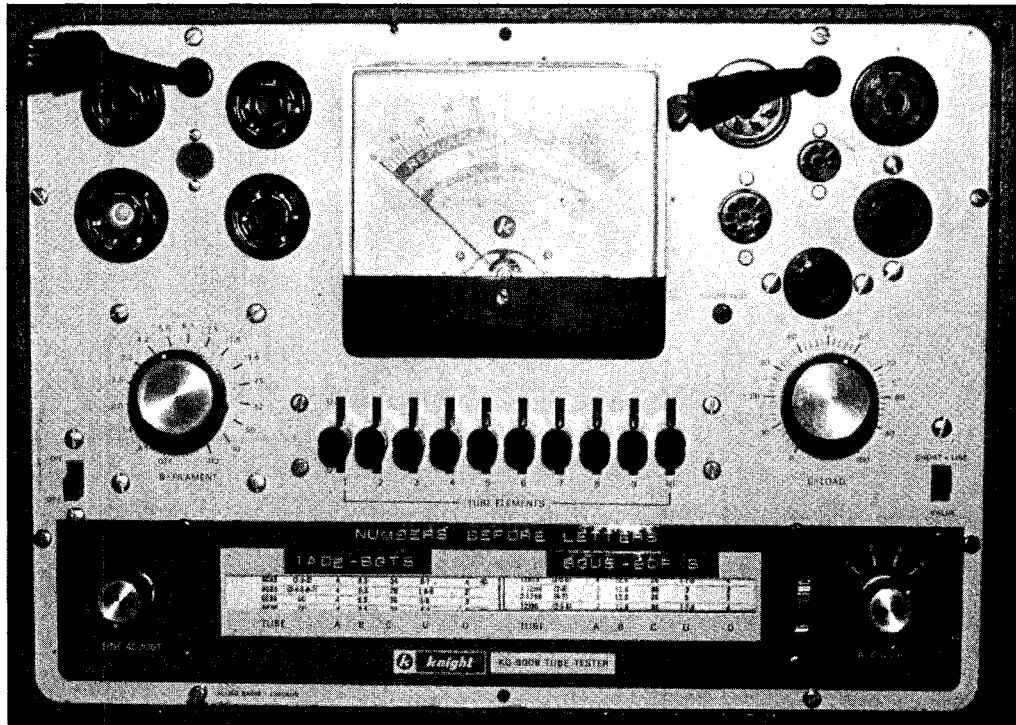
Basic Test  
Equipment

Figure 13: A tube tester

the tube is leaking. This may not be true for all tubes, so a tester is the best way to be sure.

Tube testers are not readily available on the market. Finding one will require some foot work and phone calls. Antique stores are a good source to find a low-cost, portable home tube tester. Finding a vendor for tube replacement is difficult and in some areas impossible.

**Automatic Test  
Equipment**

The ultimate piece of test equipment is a fully-automated test unit. Since more electronic appliances are becoming microprocessor-based, more systems have built-in testing routines. With the right test equipment, one can read and process this information. Also, equipment circuits of today are so closely dependent on each other that proper measurements must be taken simultaneously to be valid.

As appliances become more complex, so do the test units used to repair them. Figure 14 shows a stand-alone, fully computer-based and controlled automatic test unit. More manufacturers are creating test units or cards that can be added to your home PC, allowing complete analysis of an appliance being tested.



4/2

Basic Test Equipment

There are two basic methods of creating automatic test equipment (ATE):

- stand alone
- PC based.

ATE is programmable and capable of performing and displaying measurements autonomously or in a system. Measurements are not limited by the user with this sort of test equipment, and any number of different measurements can be performed in any number of periods. With a digital meter you can only take a reading and process it at that point in time. With an ATE, the unit can be programmed to take samples at predetermined times over a time period, store the data, and display it at the convenience of the operator.

If you have a PC, an ATE may be the best way to go. In the long run, the costs would be far less than buying separate individual pieces of test equipment.



Figure 14: Computerized automatic testing device

**4/2**

**Basic Test  
Equipment**

---

---

---

---

## 4/3 Advanced Test Equipment

### 4/3 - DMM Digital Multimeter

#### Introduction

A good, reasonably priced digital multimeter (DMM) can be one of your best pieces of test equipment. The DMM can be used for measuring transistors, transistor checking, continuity checking, diode checking, capacitance checking, and voltage checking. A digital meter inputs analog signals and then converts the output through an analog-to-digital converter and displays it digitally.

The meter in Figure 1 has 24 possible ranges with six different input slots. There are two switches, one for power on/off, and the other for AC/DC switch selection. The AC/DC switch selection only affects the voltage ranges.

The inputs are the transistor slots, capacitance slots, volt/ohm/Hz input, and two amperage inputs. There is also the common or black lead slot. The mA slot can handle up to 999 mA before blowing the internal overload fuse. The 20 A slot

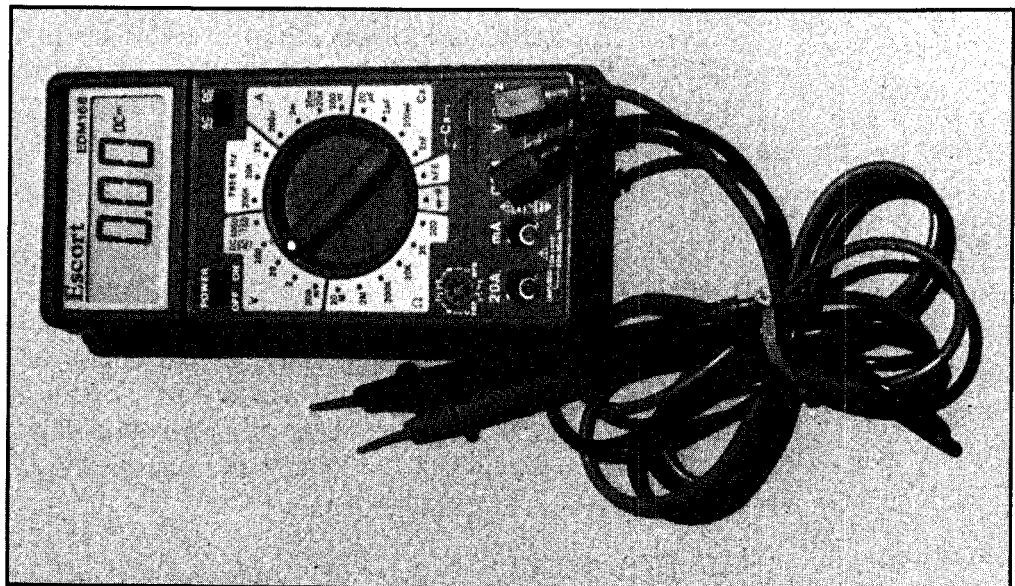


Figure 1: Digital multimeter

can handle up to 20 amps before blowing the internal fuse. The exact specification for the maximum amperage that can be inputted to the unit in each of the slots will be noted on your meter or in your manual. Exceeding these limits can be costly.

The output is in the form of discrete numbers rather than as a pointer deflection on a continuous (analog) scale. The major advantages of this are accuracy, speed and ease of use.

### Why Digital and Not Analog?

Compared to an analog meter, the DMM is superior in almost all areas. The display can be complete with decimal point and polarity signs. The DMM eliminates the problems of the scale factor, interpolation and lead connection.

The DMM has greater resolution than the analog meter. The analog meter can be accurate to one part in one hundred, or one percent. A DMM has an accuracy of less than  $\pm 1$  percent of the reading (any reading) and a resolution of one part in 2,000. The best DMMs are accurate up to  $\pm 0.0005$  percent with a resolution of about one part in 100,000.

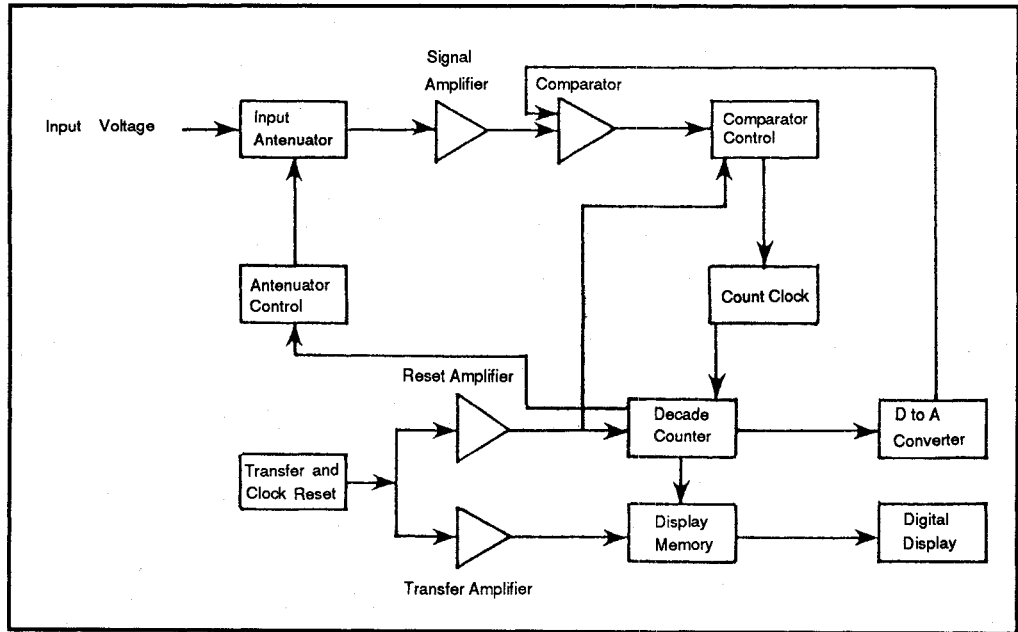
An analog meter takes about a second or more to make a reading. A DMM makes about 5 readings per second, and in some applications much more. Therefore a DMM is more accurate and faster. It is often worthwhile to spend a little extra to go digital.

Figure 2 illustrates the difference between digital and analog. The circuit being tested has a transistor, Q100, with a .5 volt difference between the base and emitter. If the value is off by just .1 volts, the output will change the next processing circuit. Using an analog meter with an inherent accuracy of about one percent is not sufficient in a circuit allowing no more than a .1 percent variable. The DMM would have no problem testing this.

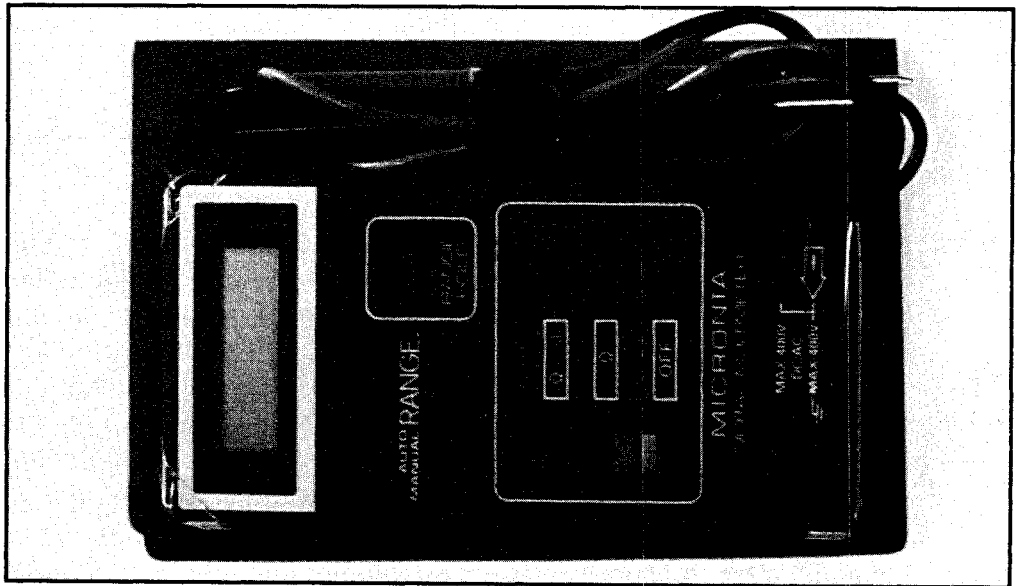
### DMM Features

DMMs have built-in autopolarity features. You do not always have to remember which leads should be hooked to what. This feature will make circuit troubleshooting easier when you have to make positive and negative voltage measurements. The plus or minus sign may be visible next to the numeric display to indicate polarity. Some meters will only turn on a negative sign with the assumption that all other numbers are positive readings. This feature is useful when adjusting circuits like FM detectors on stereo equipment and circuits that must be adjusted to a null value.

With the autoranging feature in DMMs, the meter will indicate whether the range is too low or too high. Some meters, like the one shown in Figure 3, automatically choose the best scale for the equipment being tested.



**Figure 2:** An example circuit



**Figure 3:** An autoranging DMM

Most DMMs have an overload protection circuit that shuts the unit off, or blows an internal fuse when exceeded. Your DMM manual will indicate the operating range for your meter. Typically, voltages may be measured to 1000 V AC and DC, and up to 10 A.

Some meters will not be protected if you exceed these limits. Take care when hooking your meter up to circuits with extremely high voltage.

### The Multiple Ranges

Figure 4 shows a multimeter with features like voltage, current (amperage), ohms, frequency, capacitance, and transistor measurements. This multimeter is also capable of measuring diodes or continuity checks.

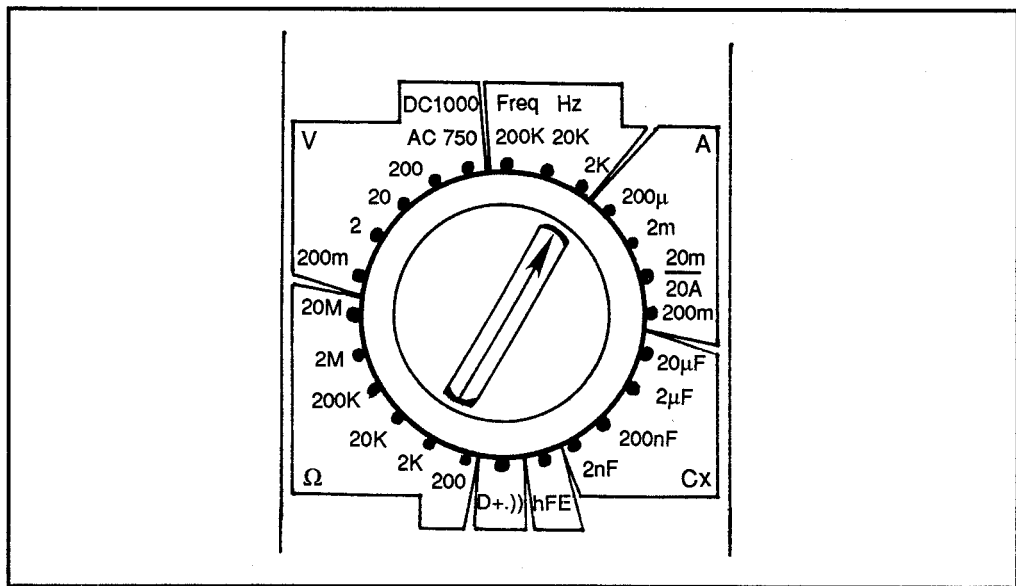


Figure 4: The ranges of a DMM

### Voltage Tests

Voltage checking with a DMM is a simple process. Select the range high enough to measure the voltage you are checking. The DMM meter can handle DC voltage to 1000 V and AC to 750 V. If you do not know the range, begin at the highest setting and work your way down. This will protect the meter. Although most DMMs are protected by an internal fuse, if this blows you will have to change it before continuing. By using a higher range, this cannot happen.

Connect or touch the black lead to ground and the red lead to the test point. Read the meter. If the meter displays a 1, beeps, or shows a plus sign, the selected scale is not high enough. If the reading does not seem satisfactory, try the next scale down to increase the significant digits. Next to the numeric display will be the words AC or DC and possibly a minus or plus sign. Readings in excess of the meter capability will ruin the meter.

### Current Tests

To measure current, a circuit in the DMM converts the current to a voltage drop across a known resistor and measures the voltage. Figure 5 shows an example

circuit of how this is accomplished. In this example, current flows through resistors R2, R3, R4, and R5, which develop a maximum voltage. Changing the input selector to less resistance allows more current to flow and a higher value of current to be read.

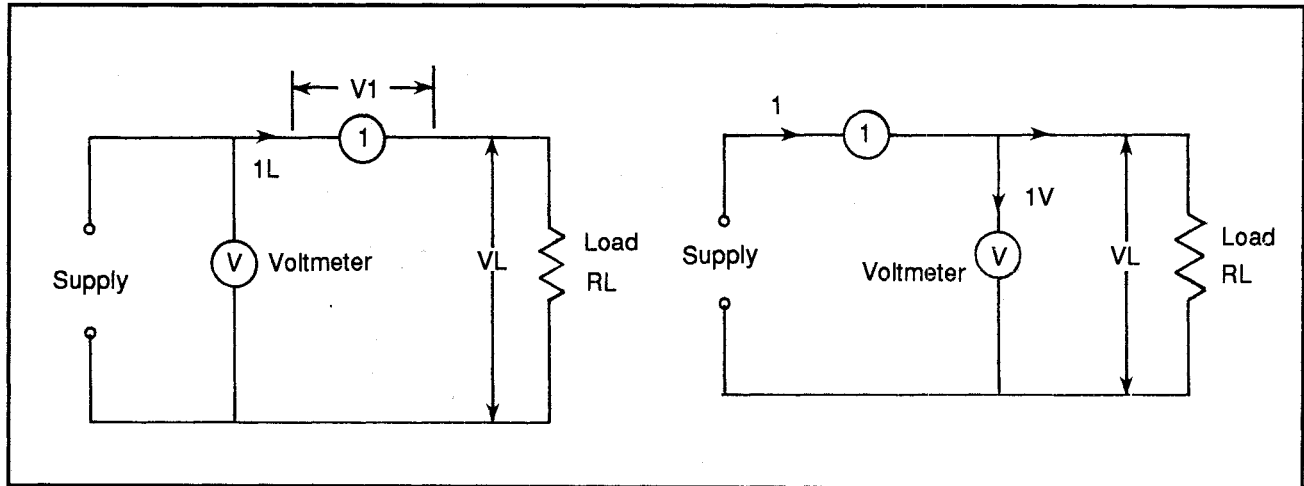


Figure 5: Current testing circuit

### Ohms Tests

To measure ohms a DMM will supply a reference current that will generate a constant current across the unknown resistance so that the voltage can be measured. (Figure 6 shows a circuit that may be used to do this.) For example, the unit might be required to measure between 0 V and 1 V across the resistance X ( $R_x$ ). If  $R_x$  is 0  $\Omega$  (no resistance) then the voltage will be 0 V. When  $R_x = \text{infinity}$ , the voltage exceeds 1 V and the meter indicates an over-range condition.

Using a 1 mA current source, we will achieve 1 V when  $R_x = 1,000 \Omega$ . As a higher

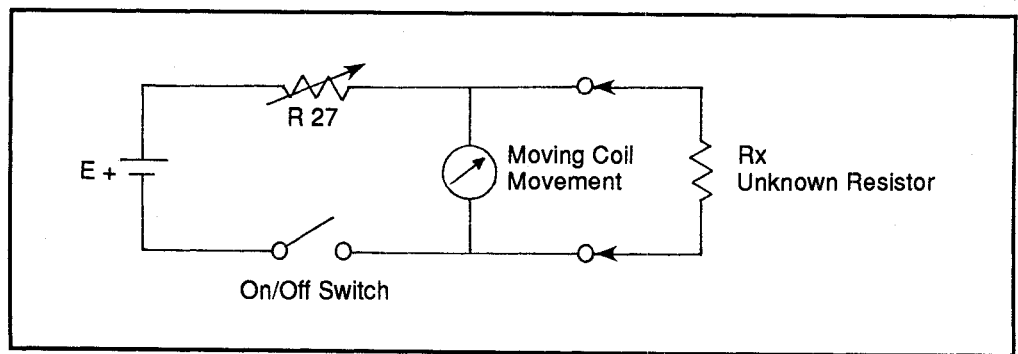


Figure 6: Resistance checking circuit

resistance is measured, a lower current value is needed. To measure a  $1\text{ M}\Omega$  resistance would then require a  $1\text{ }\mu\text{A}$  source. Each range of the DMM will use a different current reference voltage, and these specifications may be present in your manual.

Using an ohms checking range can be accomplished in circuit or out of circuit. Attaching a resistor to a meter out of circuit will indicate the resistance for the tested resistor. Checking in circuit will give an accurate reading, but additional circuits may cause this reading to be false or altered. In the sample meter, you can read resistance as high as  $20\text{ M}\Omega$  and as low as  $0.1\text{ }\Omega$ .

### Frequency Tests

The meter in Figure 7 can register frequencies up to  $200\text{ kHz}$ . Some meters may be able to do more, others less. Next to the numeric display will be the kHz symbol. Frequencies in excess of  $200\text{ kHz}$  will not damage the meter but they will not be able to be read. This meter can read a minimum of  $1\text{ Hz}$ . When connecting, start with the highest meter setting and connect the probes. Scale down step by step as necessary.



Figure 7: A frequency counter



**Diode Tests**

Diode checkers of DMMs simply pass a low current through a diode to indicate forward voltage, short/open, and good/defective error. Proper connection of the anode and cathode are required for testing. The display will indicate the forward voltage drop of the diode. A good silicon diode will show between 0.500 V and 0.900 V. If the diode is defective, the reading will be 0 indicating a short circuit. Reverse the leads and see if the display shows a 1, which indicates a good diode. Any other value may indicate a bad diode.

When checking continuity, a buzzer will sound and the scale should read 0. Any other reading will indicate some form of resistance or the presence of a short. Any resistance under 100  $\Omega$  will set off the buzzer.

**Capacitance and  
Transistor  
Measurement**

By setting the range selector to the Cx position, you can measure the capacitance in the capacitance measuring socket. Before connecting any capacitor into the socket, short the capacitor leads together to discharge it. Any voltage sent to the measuring socket may damage the DMM.

Set the meter selection to the Cx position and insert the capacitor into the socket. Take care to note the correct polarity for the capacitors, if applicable. Read the meter. This particular meter can measure between 2 nF and 20  $\mu$ F.

**Transistor hFE  
Measuring**

Setting the range selector to the hFE position will allow the measurement of PNP or NPN transistor types. The transistor must be inserted into the correct sockets as noted on the meter or in the meter manual. After the transistor is inserted into the unit, it will indicate the correct hFE value for the tested transistor.

**4/3**

**Advanced Test  
Equipment**

---

4/3 - DMM

---

Digital Multimeter

---

---

## 4/3 - F

### Frequency Counter

#### An Introduction

Frequency, time and event measurements are usually provided by test equipment with some type of counter (usually frequency counters or universal counter timers). These counter devices gate a signal over time and count the number of pulses of the signal during that time.

Figure 1 shows a basic general purpose counter. General purpose counters can measure frequencies from DC to about 500 MHz. Typically a general purpose counter will have two input channels. Each channel is identical in operation and either channel can be used to measure frequency. Through the use of various

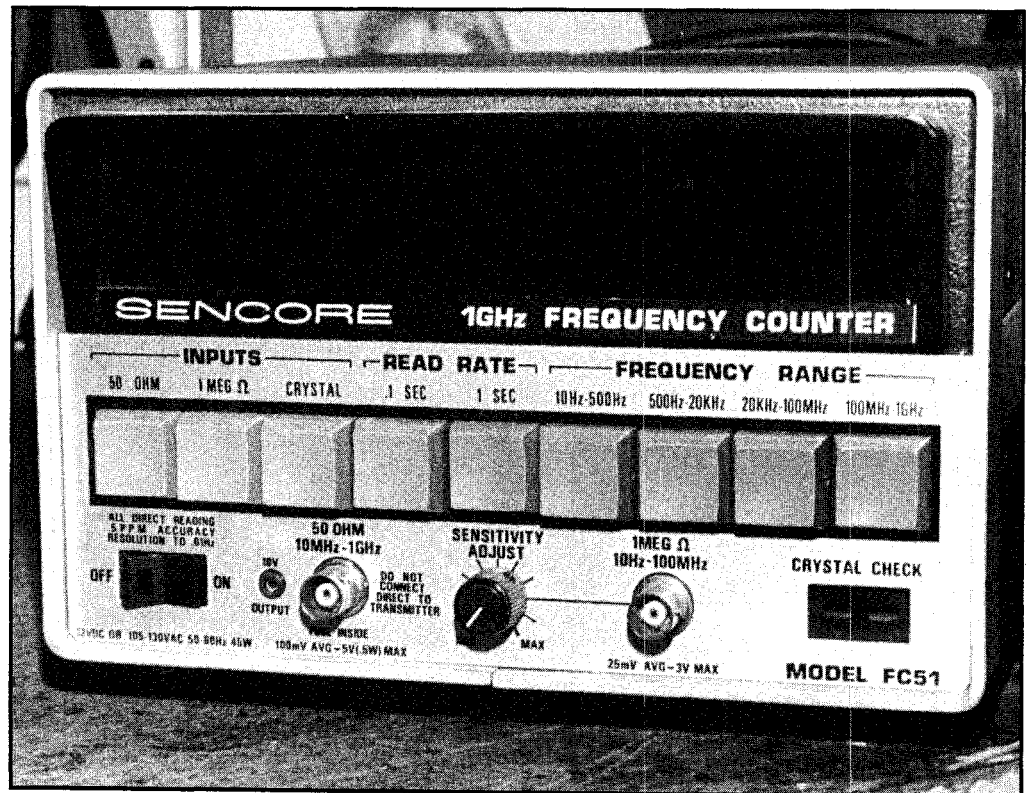


Figure 1: Frequency counter

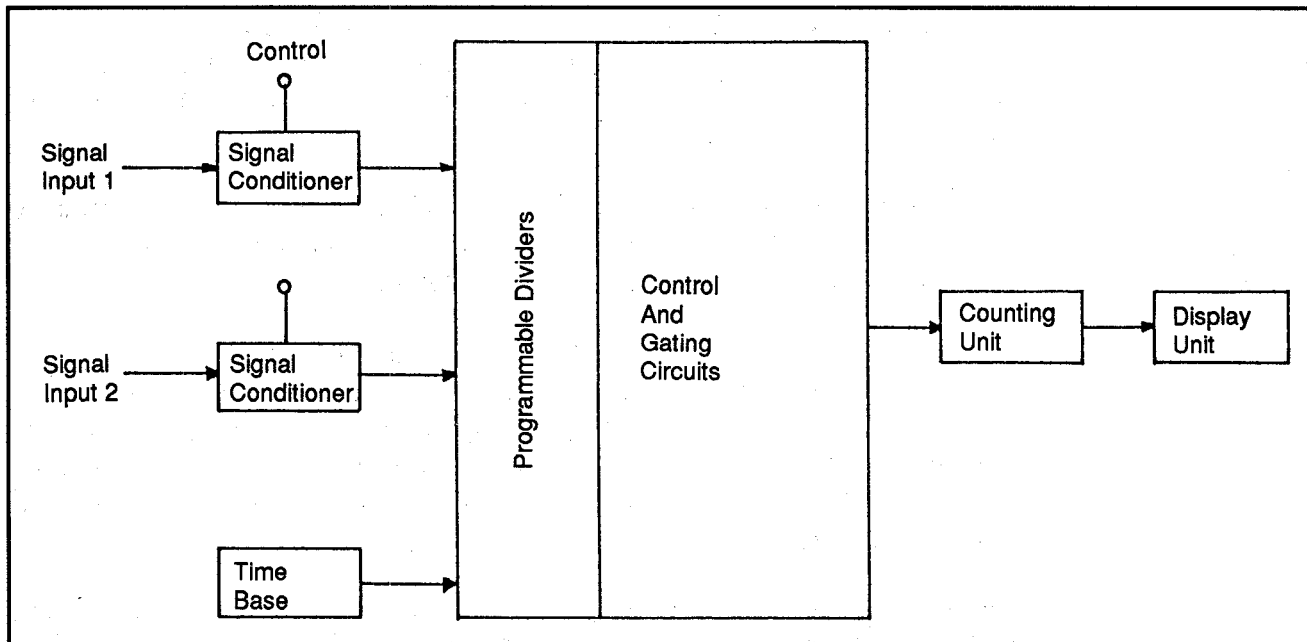
controls, signal conditioning is possible. It is also possible to adjust signal components like signal attenuation and trigger level.

Channels A and B are direct gated counters and combined with reciprocating gated or multiplying counters measure the 500 MHz level. Frequency counters able to measure above this level will include a third channel, C, which is designed to use higher frequency adaptations of direct gated counters. Higher frequency circuits are usually separate from the lower frequency circuits to avoid the possibility of higher frequency interference.

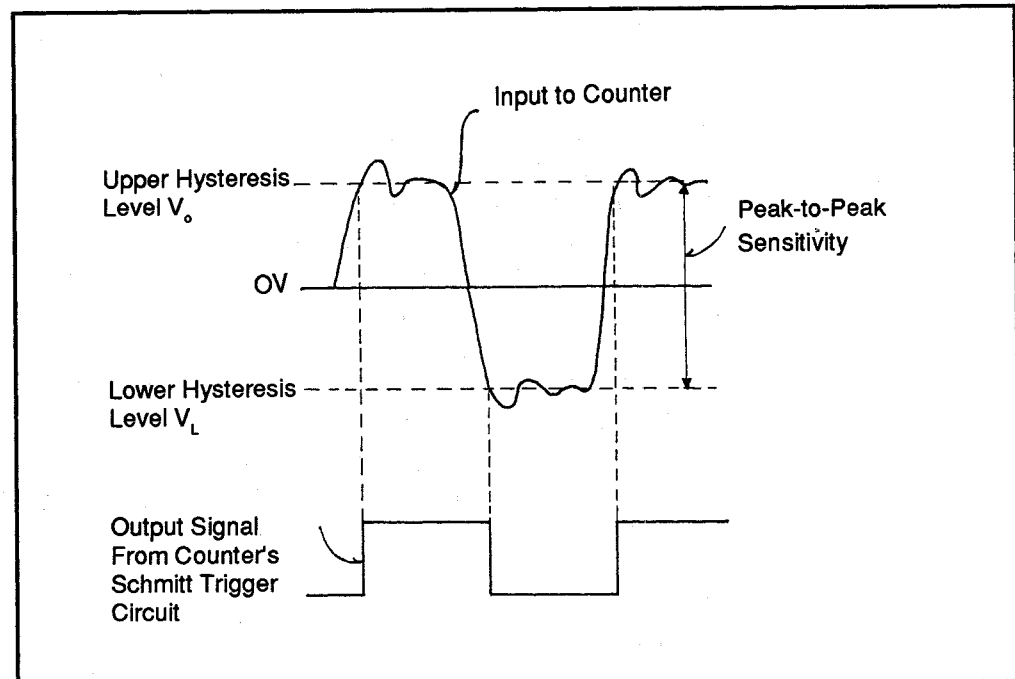
Figure 2 shows a block diagram of a basic counter. The input signal has to be cleaned up before being processed. This occurs in the signal conditioner. The signal must be decreased if too high, and when too low, amplified. The signal must also be adjusted to be a clean square wave. If the signal is DC, it is converted to AC to eliminate undesirable DC bias on the signal.

The frequency counter then varies the slope of the signal and sharpens it by sending it through a Schmitt trigger. In the Schmitt trigger, hysteresis is added, making the system less sensitive to noise. Figure 3 shows the effect of the counter's Schmitt circuit. The hysteresis band, and the point of trigger, is sometimes adjustable on counters to allow more control over the waveform.

The counter gate is controlled by an internal time-base generator. This circuit is



**Figure 2:** Block diagram of a basic frequency counter



**Figure 3:** Schmitt trigger

a stable reference oscillator, usually set at 1, 5 or 10 MHz. The crystal is either a temperature compensated crystal oscillator (TCXO) or an oven controlled crystal oscillator (OCXO). TCXOs require microprocessor control and are less accurate than OCXOs. Time-base can be input from an external source when the internal source proves to be inaccurate for certain applications. Standard reference signals such as a broadcast signal may then be used for reference rather than relying on the internal time base.

Both the time-base signal and the input signal are sent to the programmable dividers. The dividers provide independent control over these input signals to meet the requirements of different measurement modes.

Flip-flops, registers, counters and gates are found in the control and gating section. These sections control the signal path through the counter in order to get the desired measurement mode. The internal time base normally controls the counter gate, but by allowing the gate to be controlled externally and counting the time-base signal pulses, a measurement and display of the time interval between opening and closing the gate is made.

The number of pulses passing the gating circuit is measured by the counting unit, and this information is displayed on the LCD, LED or VDT display. First,

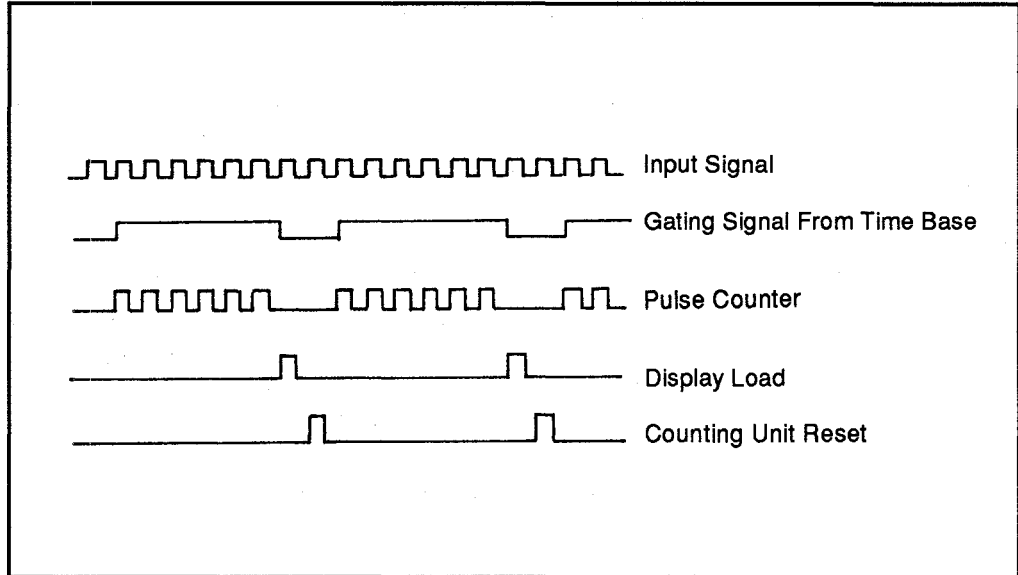


Figure 4: Taking a frequency measurement

however, the unknown time interval measurement of the input signal is compared to a known quantity (the time-base) by gating. The frequency can be calculated and displayed when the period of the time-base signal is known.

By opening the counter gate manually, the device can do event counting. This is done either by a front panel button or by a pulse input which allows the counter to add the received signal pulses to Channel A. A received pulse going to Channel B closes the gate. The counter displays the number of pulses collected at Channel A during the opening and closing period of the gate. During this type of counting, the time base is not counted or used to control the gate of the counter.

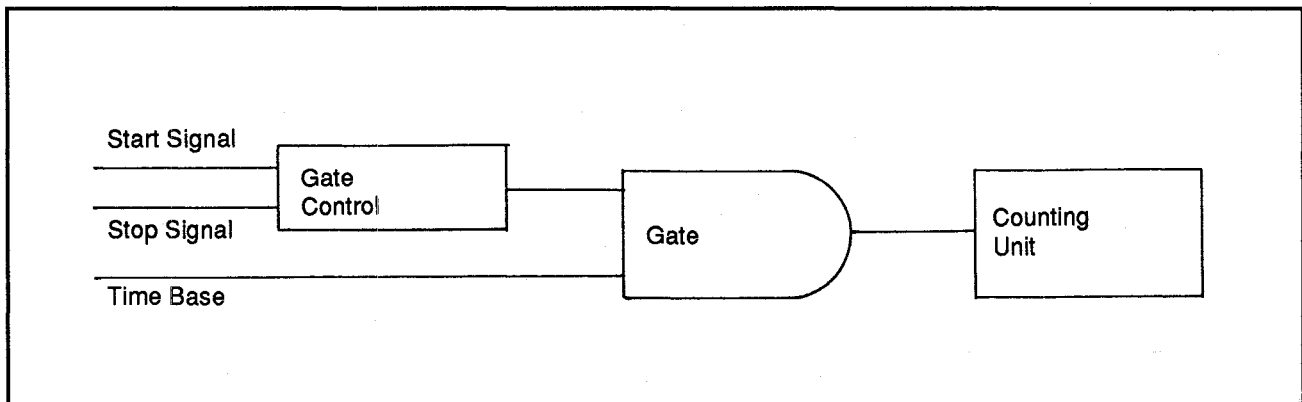


Figure 5: Time interval measurement technique

## Measurement Process

There are several different modes with which counters operate to measure different parameters. These parameters include: frequency, time interval, totalizing, period, and ratio.

### Frequency Measurement

Figure 4 shows the circuit arrangement for frequency measurement. Frequency measurement is the most common counting method. In this circuit the time-base controls the operation of the gate. The time-base will open the gate and allow counting for a given time ( $t$ ). The total pulses ( $n$ ) are counted, then divided by  $t$  to get the frequency ( $f=n/t$ ) of the input signal. For example, if there was a count of 50,000 over a period of 0.2 ms, the frequency would be 250 kHz.

A more accurate way to measure frequency is to take the average of several samples. This is known as frequency averaging. Frequency averaging can only be used on a repetitive waveform. The counter assumes that any inaccuracies are random enough to be averaged to zero on a large sample.

### Time Interval

Figure 5 shows a time interval measurement technique. The gate is controlled by separate start and stop signals. The start and stop signal parameters are controlled by setting different options on the counter.

By using time-interval techniques, measurements can be made on repetitive signals to see signals in the picosecond range. The start and stop are very important when measuring small time intervals, and they must have equal delays.

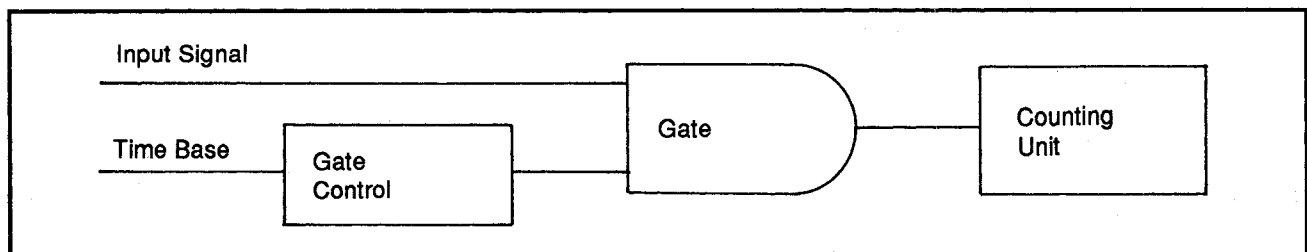


Figure 6: Period measurement waveform

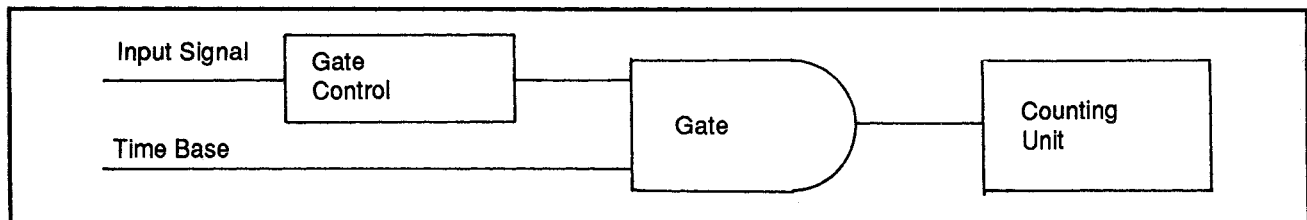


Figure 7: Ratio measurement waveform

**Totalizing  
Measurement**

Totalizing is very similar to time-interval measurement, but the time-base is replaced by the pulses to be totaled. In this mode the unit measures the number of pulses between the start and stop signals. These conditions may also be controlled by the front panel. Totalizing may be done by a preset counter in which a count value is loaded into the instrument and an output occurs only when the preset count value is met or exceeded.

**Period  
Measurement**

Period measurement (Figure 6) is the time required for a signal to complete one cycle. The time-base pulses during the time the gate is open are totaled by the counting unit. When checking low-frequency measurements, it is best to use period measurements. Period averaging is a technique used to increase the accuracy of period measurements. In low-frequency measurements a long measurement time is needed. To measure within .01% accuracy you would require 100 seconds to obtain a resolution of 1 Hz. One way to measure low frequencies is to multiply the low signal by a factor of 100 or 1000 before being counted. Then the output is divided down by the same factor to give a proper display.

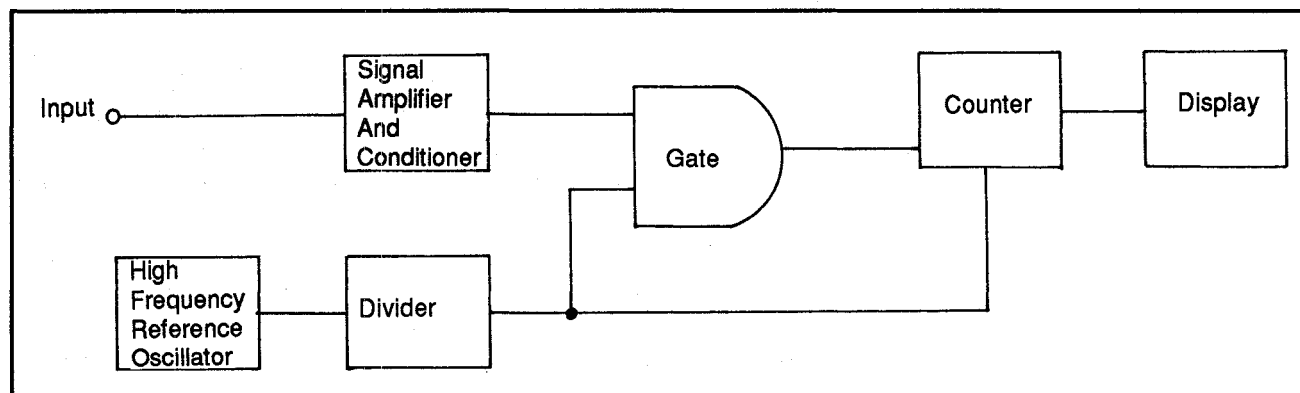


Figure 8: Block diagram of a high frequency counter

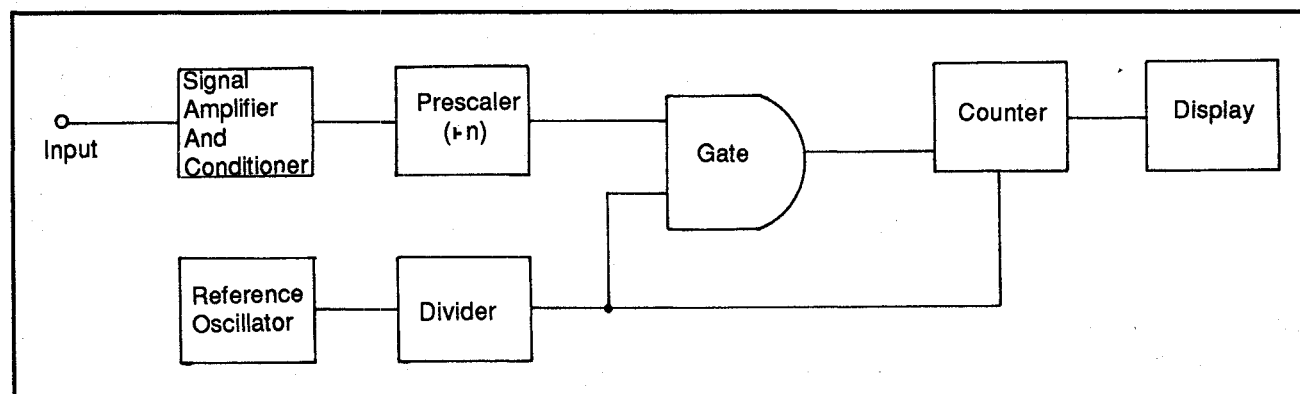


Figure 9: A prescaler circuit



**Ratio  
Measurement**

Figure 7 shows the circuit arrangement for ratio measurement, which is the same as that used in frequency measurement. The ratio between the two input signals is measured.

To get a ratio measurement, the high frequency is fed into the signal line and the low frequency is fed in to replace the time base. The low frequency controls the opening and closing of the gate, and the high-frequency pulses are counted and ratioed against the low. The frequency count is sent to the display. To increase the accuracy, the unit may average several samples before displaying a frequency count.

**High-Frequency  
Counting**

There are two basic types of frequency counters available: those that measure high frequencies and those that measure low frequencies. High-frequency counters use direct-gated counters.

In direct-gated counters, the output of a high-frequency reference oscillator, or time-base, is divided to achieve very accurate, controlled time periods. Figure 8 shows a block diagram of an average high-frequency counter, direct-gated circuit.

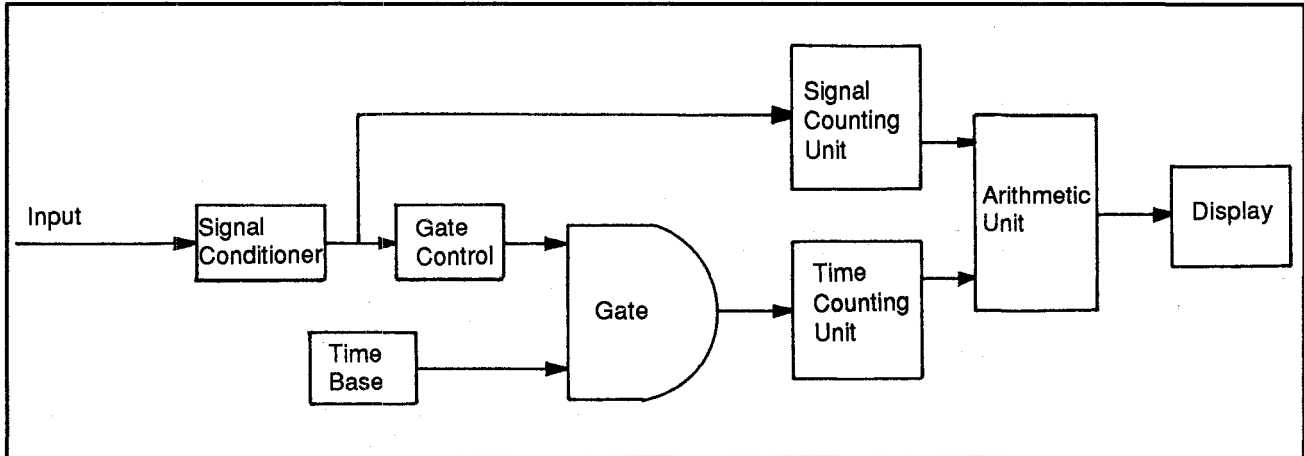
Direct-gated counters are very good at measuring signals above 500 MHz. They are limited in range by the speed of the circuits themselves.

One method of measuring very high frequencies is by the use of prescalers. Figure 9 shows the block diagram of a prescaler circuit. A prescaler circuit can be an internal device, or an add-on device which, when used, will divide down the input frequency to a frequency level which the direct-gated counter can measure. The gating period in a prescaler is much longer than a normal counter. Digital counters have high-frequency limitations but prescalers do not since they are simple dividing circuits.

Another method for using direct-gated circuits in measuring high frequencies is by heterodyning the input signal to a lower frequency. Figure 10 shows a block diagram of a heterodyne counter. Heterodyne counters can measure frequencies over 20 GHz and are much more complex than other counter types. The resultant signal is counted during a gated period, and controlled by the heterodyning signal before being displayed. A variation of the heterodyne circuit is the synthesized heterodyne counter which uses a microprocessor to create a synthesized oscillator reference signal and controls the measurement procedures.

**Low-Frequency  
Measurement**

A good response to a low-frequency signal requires a very long counting period. For example, to count a 10 Hz signal requires a period of 100 seconds to achieve an accuracy of  $\pm 1$  percent. Direct gating would not be very useful for this.



**Figure 10:** Block diagram of a heterodyne counter

However, by gating the time base with the input signal, low frequencies can be counted.

A reciprocating gated counter uses an arithmetic unit to count and calculate. The reciprocal is displayed as a MHz scale. If a count of 1,000 was made, the display would show 0.001 MHz or an actual frequency of 1kHz.

Another method for measuring low frequencies is by using a phase-locked loop circuit to multiply the frequency of the input signal. The output frequency from the voltage-controlled oscillator is proportional to the input frequency.

It should be noted that frequency counters are not usually made of just one circuit but are more often made from several. Average counters can measure up to 500 MHz, and use combinations of direct-gated and either the reciprocating-gated or multiplying methods. Counters measuring higher frequencies will use these combinations and additional methods. The front panel of a counter determines which circuits are used for what frequencies, with inputs for separate low and high frequencies. When using counters, it is best to know the limitations and counter specifications.

## 4/3 - LP

### Logic Probe

A logic probe is a common, inexpensive piece of test equipment designed to measure the logic level. It often resembles an oversized pencil with a tip designed to detect the voltage level at any point in a circuit that it comes in contact with.

A memory in the probe indicates if there has been a change in the logic level. The memory light will stay lit until the reset button has been pressed. Typically, a logic probe can detect pulses as short as 10 nanoseconds in duration.

The probe should measure (at least) TTL, LS and CMOS digital circuits. There is a switch to measure the different logic levels. The maximum current allowed through a probe is about 20 V, with special circuitry to avoid high-voltage overloading. Figure 1 shows a typical logic probe.

The probe detects whether an input voltage is above or below the threshold levels for the logic family chosen. This is indicated by one, several, or sometimes multicolored LEDs on the probe. In a single LED probe, the light will be on or off for the two logic levels. An improper level can cause the LED to glow at half

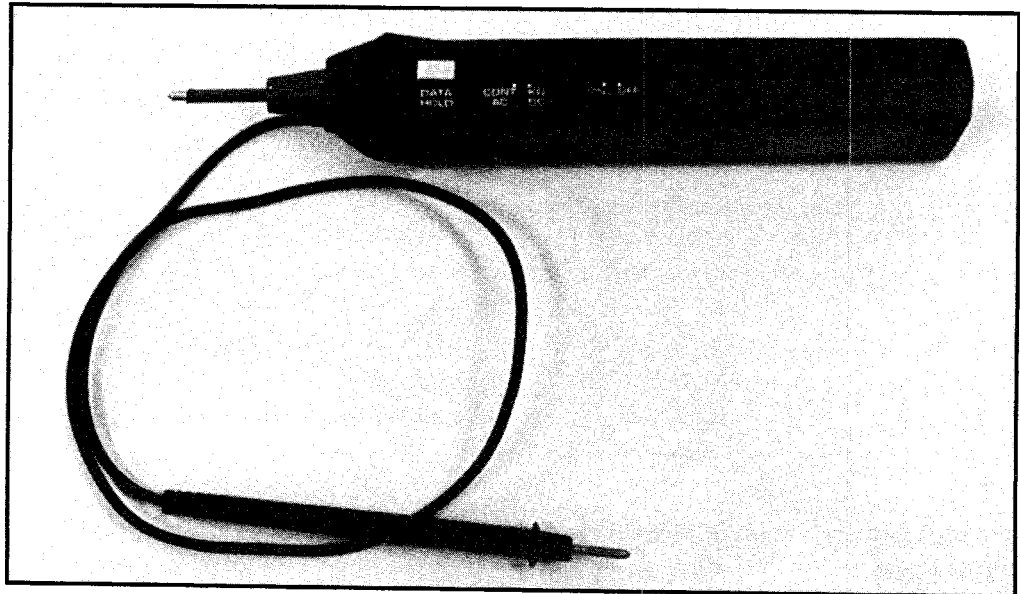


Figure 1: Digital logic probe

brightness. In multicolored logic probes an indication of different logic states is possible. A block diagram of a logic probe is shown in Figure 2.

A logic pulsar (as shown in Figure 3) can be used in conjunction with a logic probe. A logic pulsar is a pulse generator which resembles the logic probe. It inserts a voltage and current signal at any node of the circuit. The pulsar is capable of outputting a high current of more than half an amp which is sufficient to override an existing logic level at the point where it is connected. The pulse is created for less than 300 ns which will not damage any of the circuit components being tested. The pulsar can be operated in several modes, like single shot, pulse burst or pulse train.

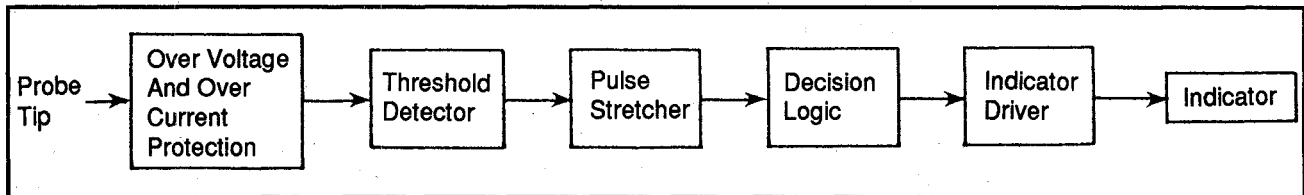


Figure 2: Block diagram of a logic probe

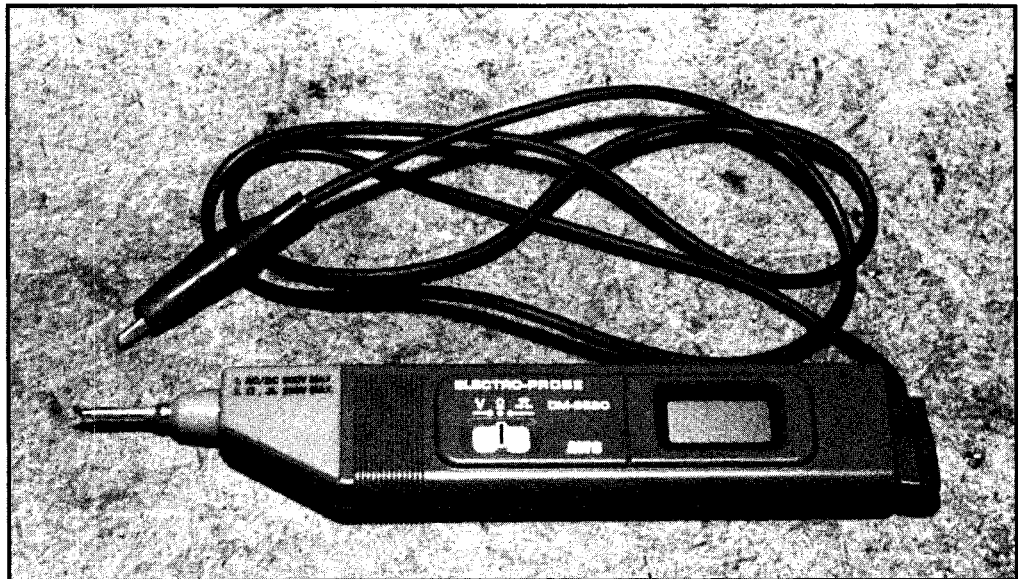


Figure 3: Logic pulsar

### Operating Principles

To use the logic probe, begin by connecting the clip leads to the power supply of the circuit you are testing. This is where the probe will get its power to operate. (Always try to use power in or very near the circuit you are testing so as to avoid

the possibility of false signals and improper voltages. Next, select the proper setting for the type of circuit you are testing (i.e. TTL or CMOS) and turn the Memory/Pulse switch to the pulse position.

Touch the probe tip to the circuit node to be analyzed. The LED (or LEDs) will indicate the status of the circuit. Refer to the logic probe manual for the proper way to read your logic probe. A three-LED logic probe chart is given in Figure 4. The chart shows the LED states, the possible input signal being measured and a description.

Each time the input changes state, the pulse LED will be activated for a certain duration of time, usually about 0.3 seconds. High-frequency signals may cause the pulse LED to flash at a 3 Hz rate. The pulse train can be determined by observing the high and low LEDs.

The memory selection of a logic probe is used to detect, store and display low repetition rate or single-shot pulses that may occur while you are unable to be present during testing. The circuit will then freeze to display the caught signal.

To reset the probe, switch the selector from memory to pulse. The switch should be moved to memory only when the probe is in contact with the circuit under test, or the probe will be given a false signal upon contact with the test point.

LED States			Description
High	Low	Pulse	
○	●	○	Logic 0—no pulse
●	○	○	Logic 1—no pulse
○	○	○	a) open circuit b) out of tolerance c) no probe power d) no circuit power
●	●		50% duty cycle
○	○		high-frequency (100 kHz+) square wave
○	●		logic 0 pulse, signal going positive
●	○		logic 0 pulse, signal going negative

Figure 4: Reading the three-LED probe

**4/3**

**Advanced Test  
Equipment**

---

4/3 - LP

---

Logic Probe

---

---

## 4/3 - O

### Oscilloscope

#### An Introduction

In conjunction with the multimeter, the oscilloscope is probably the most frequently used instrument. Figure 1 shows a typical scope found on a technician's workbench. It is more versatile than a multimeter, since an oscilloscope shows the shape of a waveform, as well as its amplitude. Without the ability to see what a certain signal is doing, you can only guess if it is operating properly.

An oscilloscope displays a graph of changing voltage in the vertical axis against time in the horizontal axis. This ability to measure in two dimensions makes the oscilloscope the singularly most accurate piece of equipment. In order to accomplish this, the bandwidth and sensitivity must be adequate for use in your applications. A scope that is unable to lock on and amplify signals in TV equipment would be completely useless when repairing these devices.

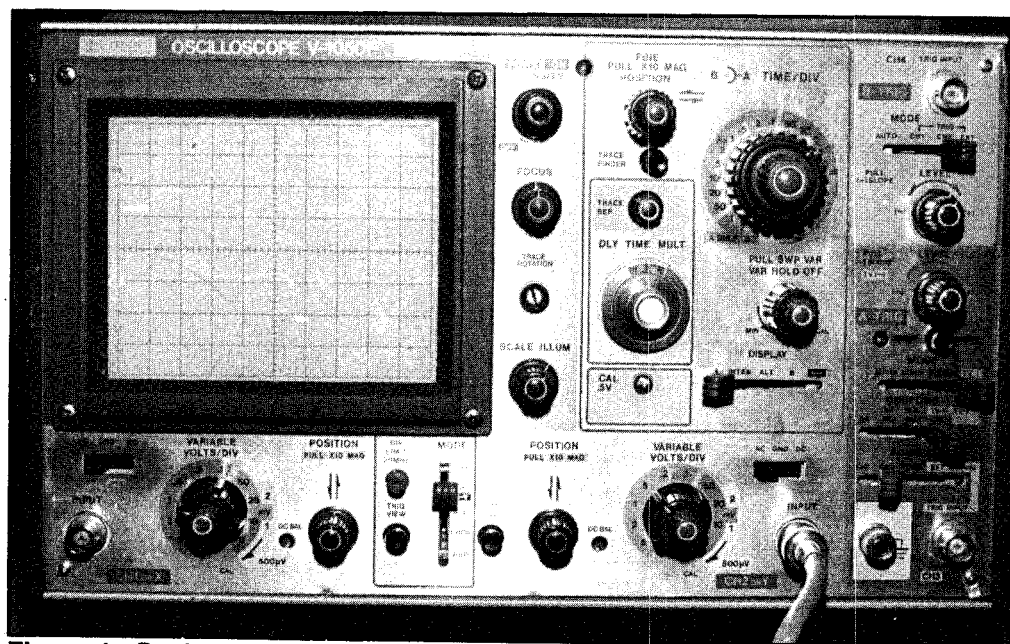


Figure 1: Dual-trace oscilloscope

Oscilloscopes can be broken down into two general categories: real-time and non-real-time. Real-time oscilloscopes (non-storage) can only be used to observe rapidly redundant waveforms, whereas non-real-time scopes (storage oscilloscopes) allow you to see singly-occurring waveforms. An interrupt request signal to a microprocessor is an example of a singly-occurring waveform. This kind of signal would only occur every so often and last for only a few microseconds. A real-time scope would be unable to view this. Figure 2 shows a breakdown of the various types of real-time and non-real-time oscilloscopes.

Most modern scopes are capable of inputting two or more signals and displaying them simultaneously. Oscilloscopes measure in upwards of 20 GHz with signals above 10 GHz measured with a sampling oscilloscope. A sampling oscilloscope holds each sample for one sampling period, and then replaces it with the next sample. If a sampling oscilloscope is used, the signal can be stored and displayed from a few seconds to a few years.

Although it is nearly impossible to choose a scope with all features for all applications, the single most important feature in a scope is the bandwidth. Using a 100 MHz scope to measure a broadband amplifier of 470 MHz would be difficult and inaccurate. The bandwidth of a scope for use in this manual will not need to be higher than about 50 MHz. For most of your applications, you should not need a scope with a larger range than this. However, frequencies that

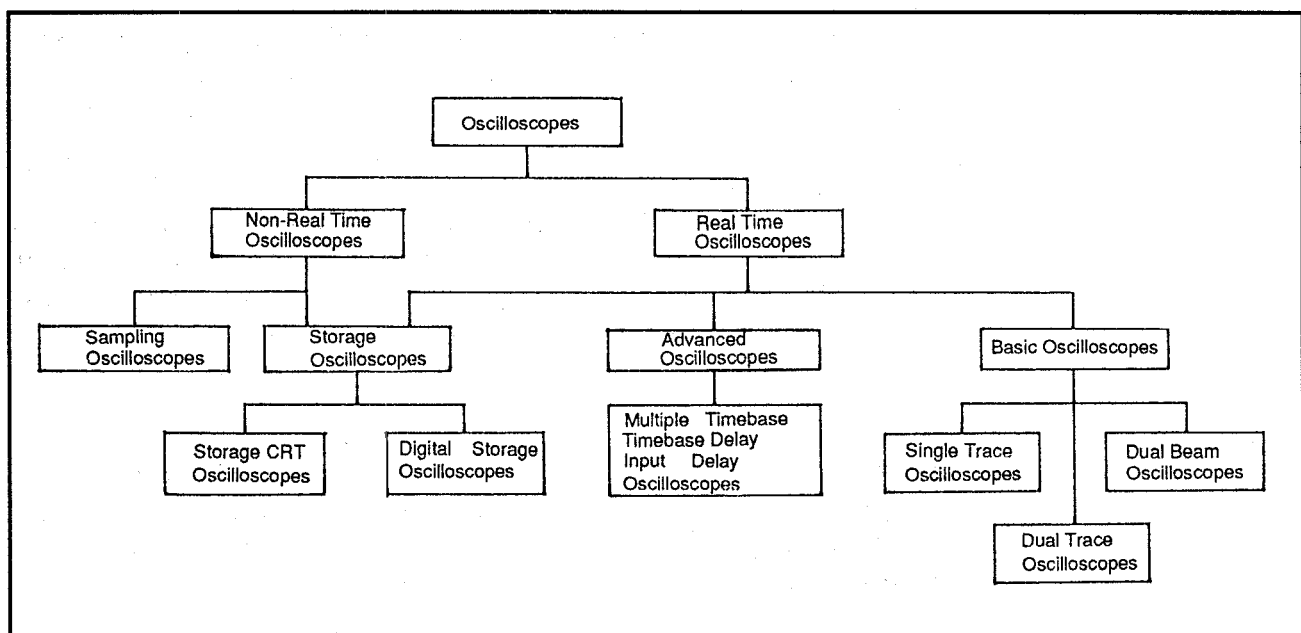


Figure 2: Family tree of the two categories of oscilloscopes



get too close to the upper limits may not produce accurate readings. For example, a one volt peak-to-peak, 3.58 MHz color signal displayed on 5 MHz scope will not read the one volt.

### Bandwidth

Bandwidth (MHz) is approximately equal to 0.35 divided by either the rise time ( $\mu\text{s}$ ) or by the band of frequencies a circuit passes. Any frequency components outside the oscilloscope's bandwidth are visible, but at a diminished size. A typical bandwidth between 30 and 50 MHz is adequate for most technician work.

Related to the bandwidth and as a consequence of the bandwidth, are the range of amplification factors of the vertical amplifier. The greater the wave's bandwidth, the smaller it will be on the display screen.

Oscilloscope screens are marked with a grid 10 centimeters wide and 8 centimeters high. Each grid square division is called a graticule. The amplification factor is denoted in volts/centimeter or volts/division. The volts/division begin from the center and proceed up the Y-axis as positive and down the Y-axis as negative. With a factor of 20 volts/cm there would be a total screen height of 40 volts (20 positive volts and 20 negative volts).

The Y-axis displays the amplification of a waveform. Typical amplification factor ranges are from about 10 mV/cm to 5 V/cm. A better scope will have a greater range.

The X-axis must have similar frequency ability to work adequately. The X range is found in the time-base generator controls of the scope. Time-base ranges refer to the time taken for the beam to sweep from the left side to the right side of the CRT display. Ranges from 10  $\mu\text{s}$  to 2 s are average.

Bandwidth specifications are most often misleading because they indicate frequency response at the -3 dB point on the bandwidth curve. A notable roll-off can be found below the -3 dB point, so the scope amplitude readings may or may not be true if the amplitude of any waveform is not a flat top with a frequency of more than 50 percent of the maximum bandwidth of the scope.

### Dual-Trace

Dual-trace oscilloscopes are the most common form of oscilloscope available. It is possible to obtain four and eight input scopes for special applications (e.g., measuring surround-sound signals all at the same time). Dual-trace or multitrace scopes can use a single split beam, or multiple beams. Dual-trace oscilloscopes are the instruments discussed and used in this manual.

A dual trace scope has: two input signals inputted via two input channels and then

sent selectively to the display screen. The display of each signal may be measured independently, together, alternately, or chopped. Each channel is referred to as A and B, respectively.

Working with a single view is fairly self-explanatory. Either the A or the B signal is on the screen and you can adjust the controls for the A or B section.

Both signals displayed simultaneously may be layered upon one another or divided between the lower and upper halves of the display. Figure 3 shows an example of two signals being compared. This works well when measuring the output of the left and right channels of a stereo unit. You could compare and match the two signals by sending the same input signal to both receiver inputs. Layering the two displays provides the means to adjust the signals to match (assuming the scope's A & B channels are set for the same settings).

In the alternate mode, shown in Figure 4, the display is switched between A and

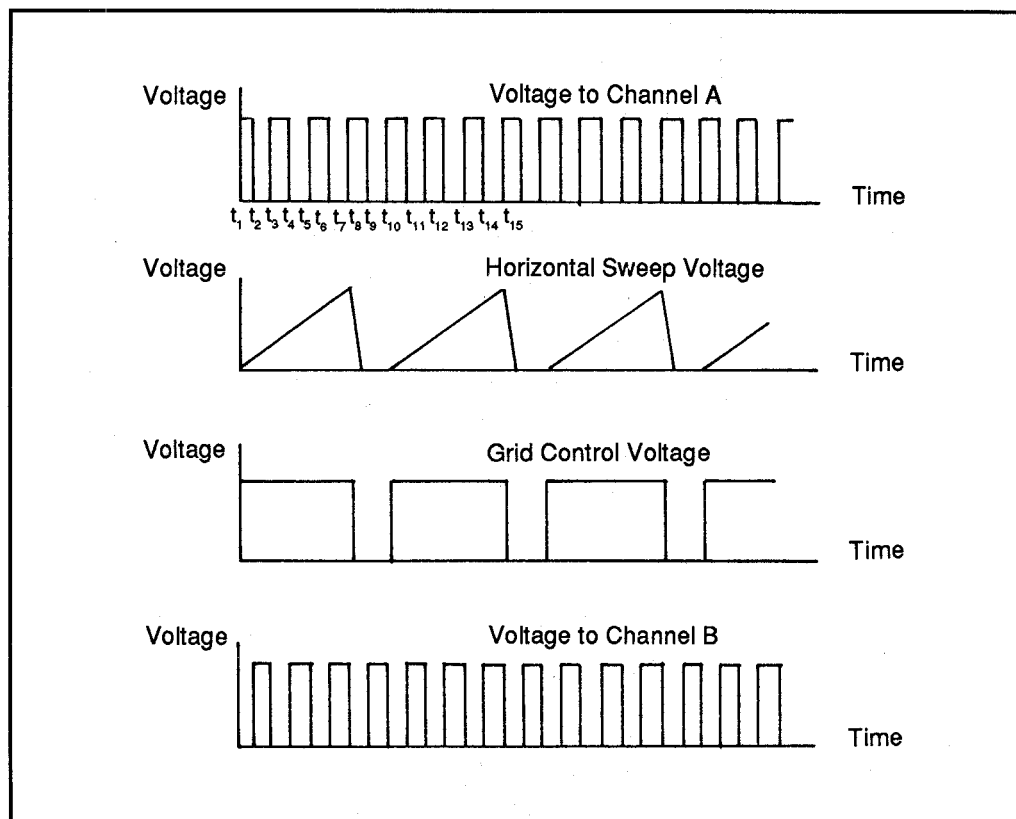
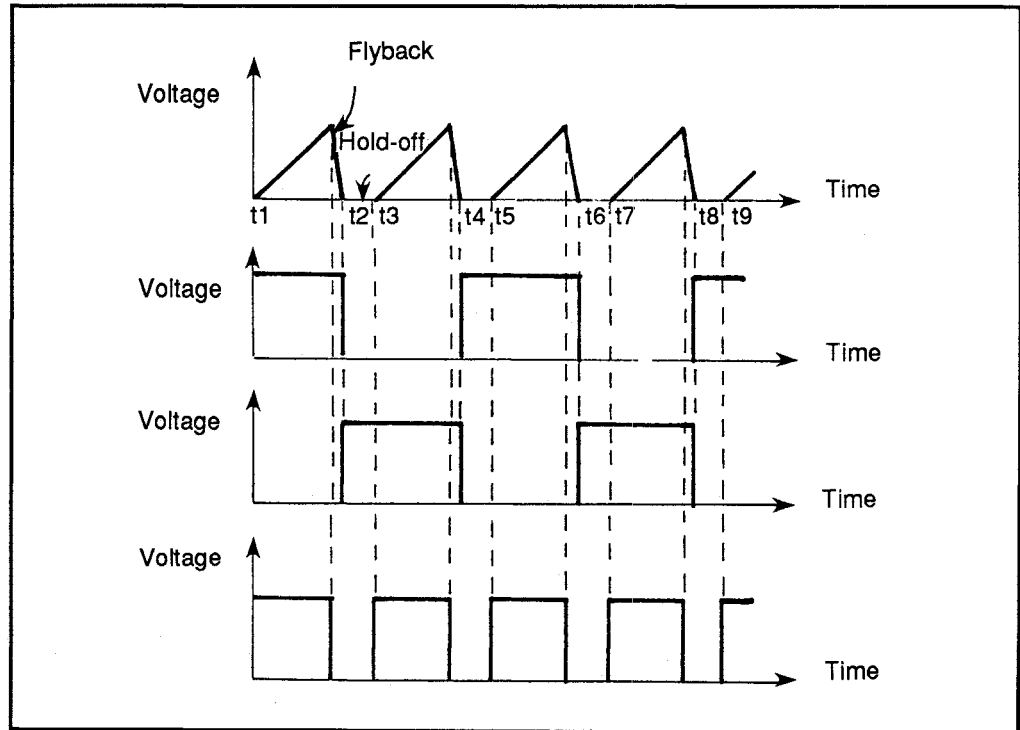


Figure 3: Two signals being compared



**Figure 4:** Alternate mode for two signals

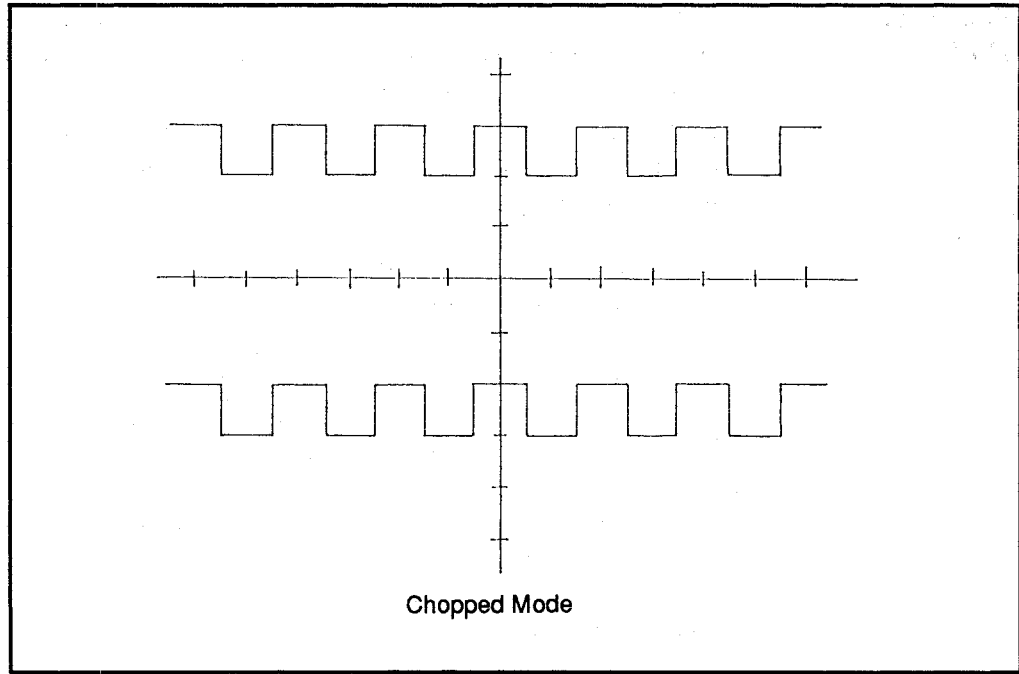
B, letting each show for one cycle of the horizontal sweep. The alternate mode cannot be used for displaying very low frequencies.

The chopped mode is shown in Figure 5. When selected, this mode allows small segments from each channel to be connected alternately to the vertical amplifier and displayed. If the chopping rate is much faster than the horizontal sweep rate, the display will be a continuous line for each channel. If the sweep rate approaches the chopping rate, the individual segments will be visible and you should use the alternate mode.

The dual-trace scope cannot capture two fast, transient events. It also cannot switch fast enough between the traces. For this to occur you would need a dual-beam oscilloscope with two separate electron beams, and two separate vertical channels.

### Trigger Input

When troubleshooting TV-related circuits, an oscilloscope with a trigger input is necessary. In a TV you will need trigger inputs for measuring correct timing of the color burst, color killer, gated automatic gain control (AGC), circuit operation and horizontal AFC. Also, a dual-trace oscilloscope with trigger input



**Figure 5:** Chopped-mode for comparing two signals

measuring stereo channel comparison, as the trigger input can make sure both signals start at the same point. This will allow for a very accurate comparison of two signals.

If a composite video signal is used for triggering the scope, a problem could arise. Most scope triggers are designed to recognize slope polarity and amplitude levels and not the difference between the horizontal and vertical sync pulses. Scopes with a built-in integrator circuit are best and are usually noted with a switch marked TV MODE. Without this filter the scope may not lock onto the incoming signal properly.

In the triggered mode, the scope screen will be blank until a correct trigger pulse is fed to the sweep system of the scope. When received, a one-shot circuit is activated, and thus the screen displays a waveform. Sweep happens only when the correct pulse of the correct amplitude and polarity is sent to the sweep mode.

Using an automatic trigger mode can be very useful. This sets the scope in a mode of operation which does not need an external trigger (sync) signal. The sweep will run at an uneven flow rate until a trigger pulse is sensed. When a signal is applied, the automatic trigger circuit produces a sharp, clean trace that is locked in tightly.

**Oscilloscope  
Probe**

The standard input resistance of an oscilloscope's vertical amplifier is 1 M $\Omega$ . A special probe is required with such a high input resistance to prevent excessive hum pickup. A screened lead capacitance of approximately 50 to 100 pF per meter and an internal vertical amplifier input capacitance of about 15 to 50 pF will create a total input capacitance of about 100 to 150 pF. This capacitance may affect measurement accuracy.

To solve this problem a passive divider probe is used. This type of probe has an attenuator built in, which increases the resistance presented to the circuit under measurement, and thereby decreases the input capacitance. A standard probe will be about 10:1 which makes a resistance of ten times that of the vertical input of the oscilloscope, or 10 M $\Omega$ , and 1/10 the input capacitance, or about 10 to 15 pF. This will effectively reduce loading.

Probes of 10 times (10x), 100x and 1000x attenuation are available, but only useful for measuring higher frequencies. The scope must be able to sufficiently amplify this signal to see it, or the higher attenuation would be useless. These are all passive probes.

Active probes are an alternative to passive probes. They use a field effect transistor (FET) amplifier which presents a high resistance and low capacitance to the signal being measured, and no attenuation, or amplification. Active probes cost more than passive probes and require a power supply (usually a battery) for the internal amplifier to function.

An oscilloscope is designed to measure voltage. However, by using a current probe you can measure the current of a circuit. This type of probe has an internal transformer to develop an equivalent voltage which is then sent to the oscilloscope. These probes have low frequency response limits, but active current probes are available to allow the scope to measure currents down to DC.

**Error and  
Accuracy**

Three main sources of error occur when an oscilloscope takes measurements. First, loading occurs, which makes the measured voltages less accurate.

When using a passive probe, you must adjust the internal probe compensation capacitor to keep waveform distortion and amplitude error to a minimum. This should be adjusted every time the oscilloscope is to be used in this way. To check the probe, simply observe a 1 kHz square wave and adjust the capacitor for clean square transition corners. Most oscilloscopes will have a 1 kHz output on the front panel to make this adjustment. Figure 6 shows the difference between a properly adjusted capacitor and an improperly adjusted one.

The second source of errors comes from the internal oscilloscope circuits. Errors can be created from incorrect amplifier gain to incorrect timing adjustments. With the vertical amplifier controls set in the calibration position, an input of 10 volts, for example, should produce a display corresponding to a 10 volt vertical displacement on the display screen. When the time-base generator controls are set in their calibration position, a pulse input of 1 second duration should produce a waveform display agreeing to that of the horizontal displacement. Using the same square wave output, the vertical amplifier and time-base generator errors can be adjusted.

User errors are the third source of problems when taking measurements. Parallax

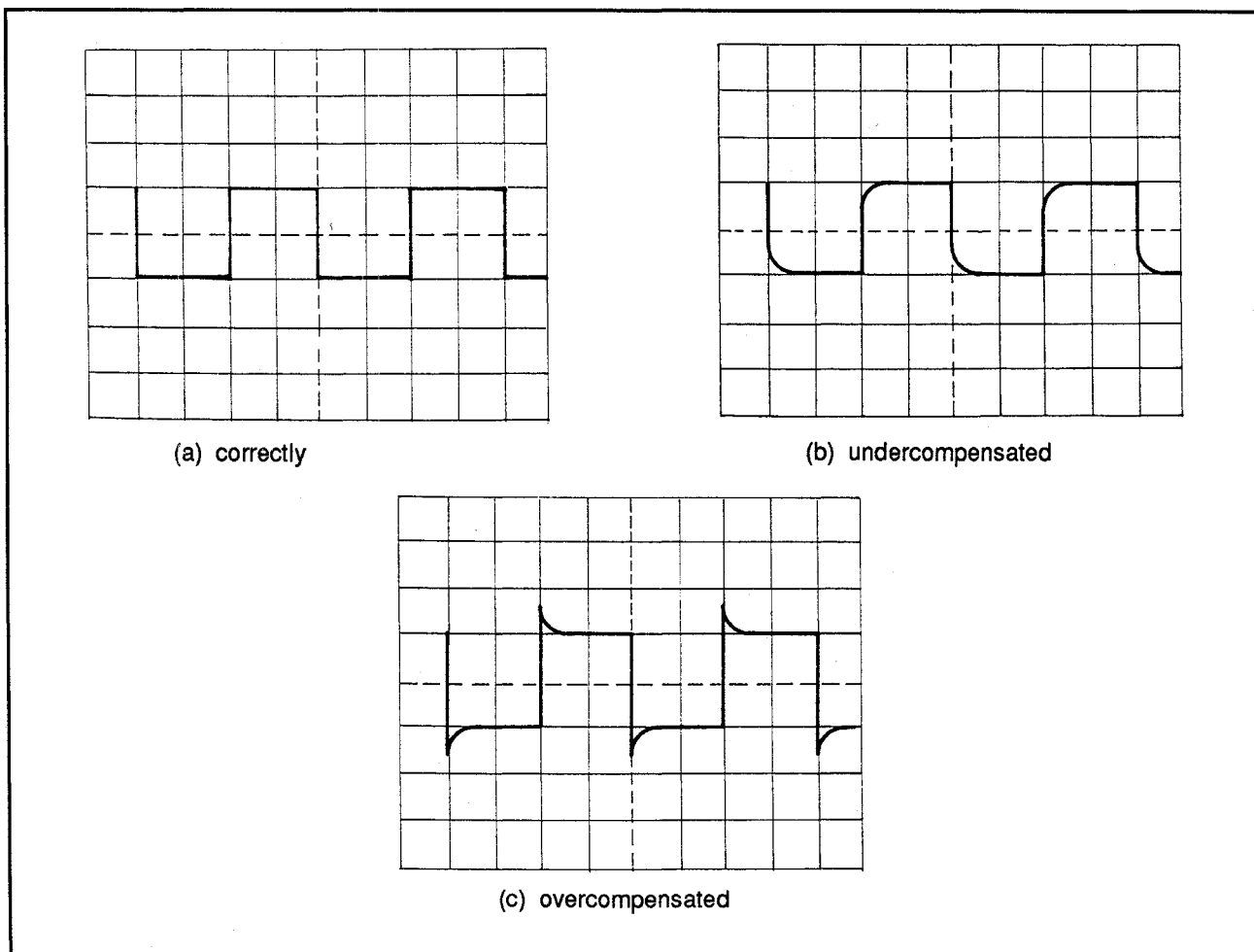


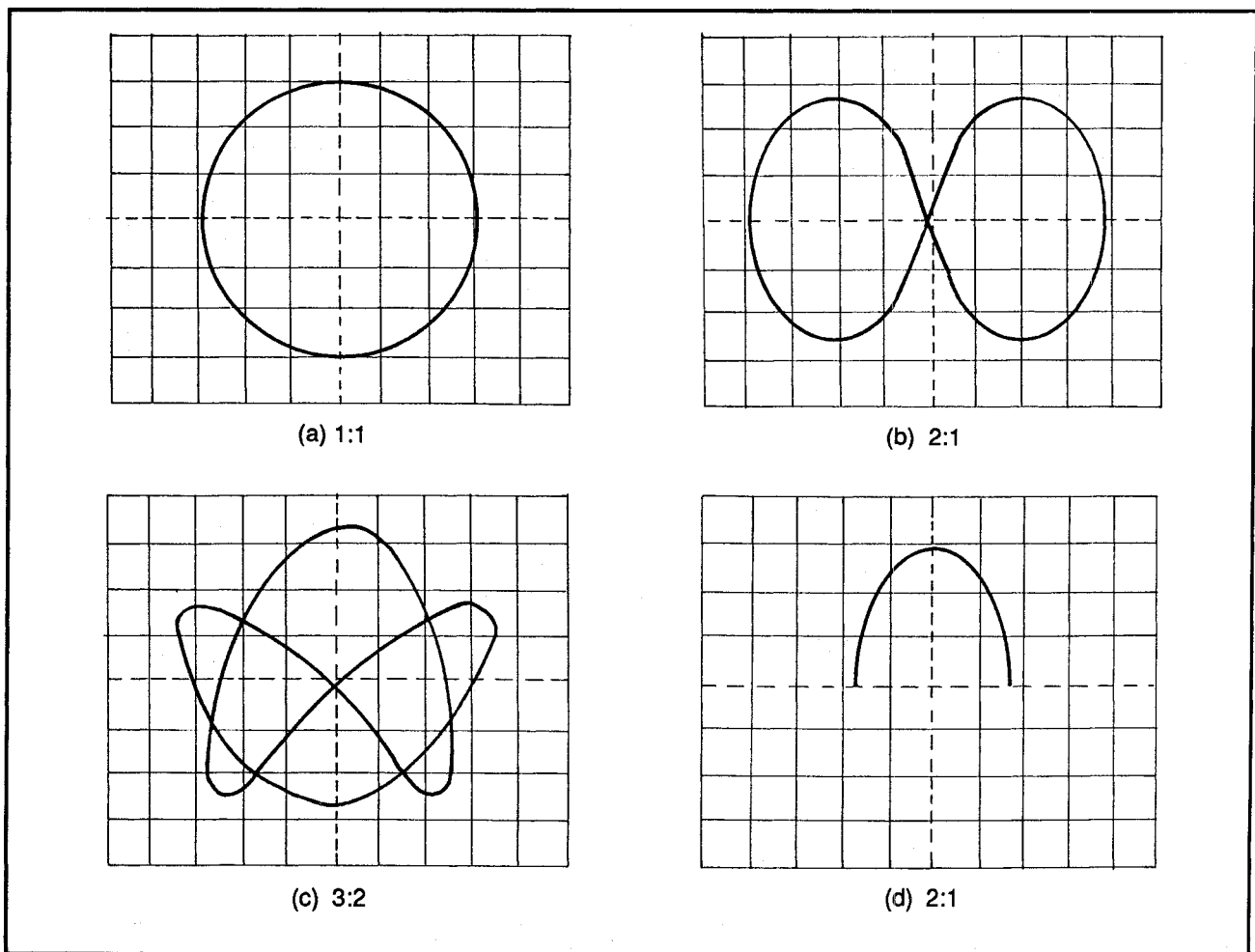
Figure 6: Waveforms for an applied squarewave when the passive probe is adjusted (a) correctly (b) under-compensated (c) over-compensated

is the most common problem. In most oscilloscopes, the graticule is in a different plane than the layer of phosphor on the screen. This means that you must look squarely into the screen to get any kind of accuracy. Otherwise, parallax will occur and change your reading.

Keep the beam set at a low intensity. A lower intensity beam produces a sharper, smaller beam, making reading easier. Beam focus should be checked regularly to maintain sharpness.

### Frequency Measurement

By measuring the period of a waveform you can find the frequency by taking the reciprocal of this value. A method of determining an unknown frequency is comparing the frequency to Lissajous figures as shown in Figure 7. These figures



**Figure 7:** Example of Lissajous figures for different frequency ratios: (a) 1:1 (b) 2:1 (c) 3:2 (d) 2:1

are generated from accurately known frequencies. An unknown frequency is compared with an accurately known frequency (Lissajous frequency) and the ratio between the two frequencies is determined.

To get the ratio of an unknown frequency and a Lissajous figure, the unknown frequency is sent into the vertical input of the scope. Switch off the internal time base of the scope, and an output from a signal generator (known frequency) is sent to the horizontal input. Adjust the sensitivity of both inputs so the display fills as much of the screen as possible. The signal generator frequency is adjusted to create a stationary display on the scope. There will now be a fixed ratio between the two inputs. The ratio is found by the number of crossing points in the display over the vertical and horizontal lines.

If the two frequencies are equal, or 1:1, then the display will be a circle as shown in Figure 7(a). This lets you know that the frequency equals the generator setting with an accuracy of 0.0001 percent. The display received depends on the frequency ratio and the phase relationship of the two input frequencies.

Figure 7(d) shows a double image. This is displayed when the high-frequency signal is 90 degrees ahead of (leading) the low frequency signal. The electron beam reverses its direction after travelling to the end of its trace.

### Time Measurement

By using the horizontal markings on the display screen and by setting the main time base of the scope, you can calculate the time between two points on a waveform. This measurement is limited to about a 5 percent accuracy rating.

To increase the accuracy of time measurements, you must use the delay time position control of the scope. The delay will have a multi-turn calibrated dial so the delay can be set precisely.

Figure 8 shows how the delay time setting can be used to measure the period of a square wave. The main time is set at a convenient value that will produce the main waveform as shown. The time delay control is then adjusted to intensify the leading edge "A" of the waveform. When the oscilloscope is on the alternate mode, the intensified part of the waveform is displayed.

The delayed time base is adjusted so its half amplitude point is on a convenient vertical grid line as shown in Figure 8. The delay dial will give you the reading  $T_1$ . You can adjust the delay time control to intensify the edge of the waveform and display it in the alternate mode with the half amplitude point at the same grid line as before. Now you will have  $T_2$  from the delay dial. The waveform  $T$  is calculated by:



**4/3**  
Advanced Test  
Equipment

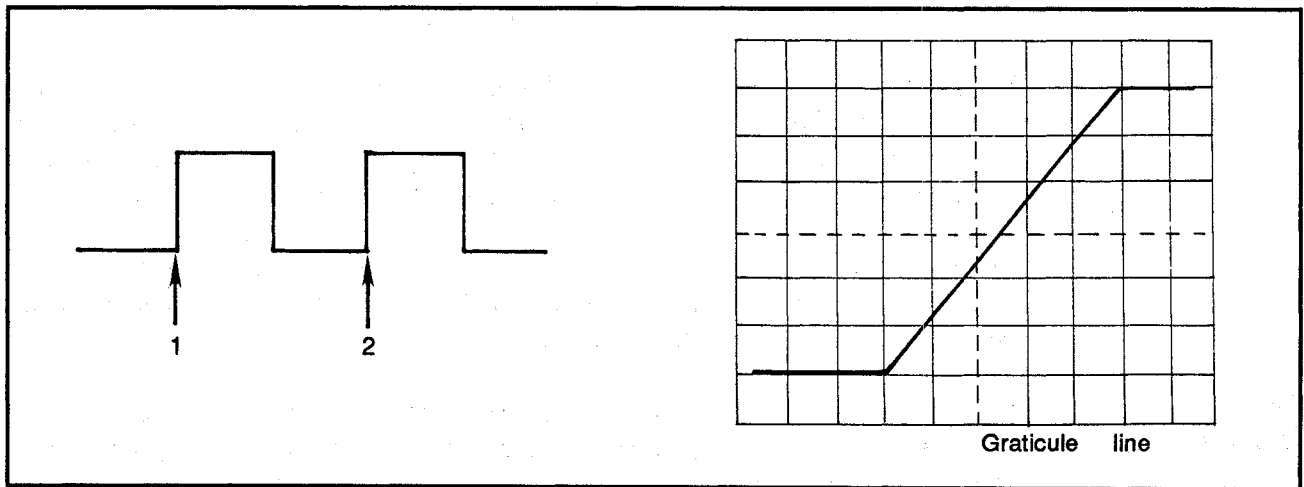
4/3 - O

Oscilloscope

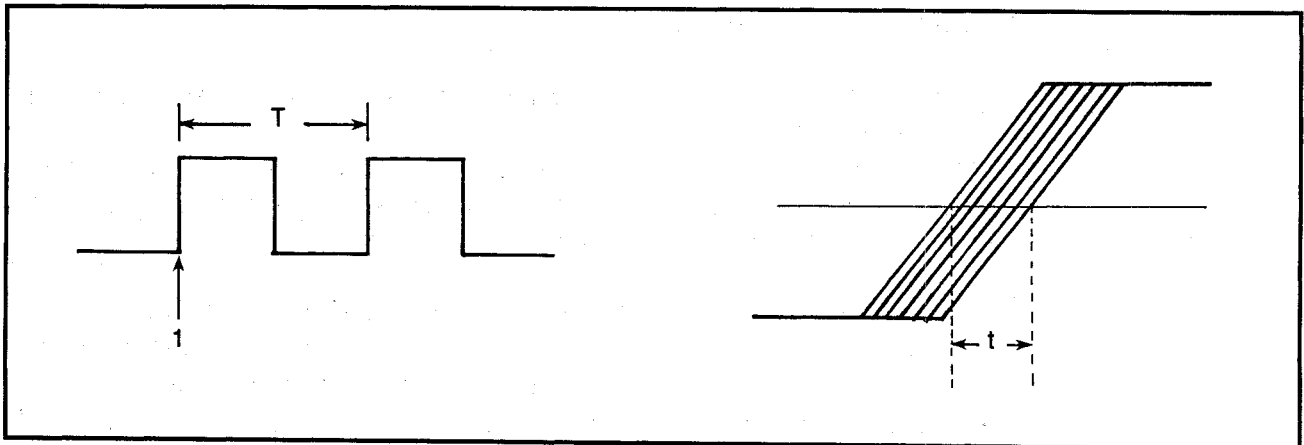
$$T = (t_2 - T_1) \cdot S$$

You can measure the pulse jitter time by, again, measuring the period T as shown in Figure 9. By intensifying edge "A" as shown in Figure 9(b) and measuring t you will get the pulse jitter, J. The formula for this is:

$$J = \frac{100t}{T}$$



**Figure 8:** Period measurement of a waveform: (a) square wave (b) display of intensified part of waveform using the delay time base



**Figure 9:** Waveform jitter measurement: (a) square wave (b) display of intensified part of waveform using the delay time base.

By using the delay time base you can measure the pulse rise time. Note the time between the 10 percent and 90 percent amplitude points. If the rise time is being measured, you will need a configuration as shown in Figure 10. Using a pulse generator, the output goes to one of the vertical inputs and the test circuit goes to the other vertical input. A correction must be made for the finite pulse rise time ( $t_p$ ) of the generator and the scope.  $t_p$  is the rise time of the generator;  $t_o$ , the rise time of the scope; and  $t_m$ , the rise time of the circuit being tested. The actual rise time is calculated by:

$$t_r = \sqrt{t_m^2 + t_o^2 + t_p^2} - 1$$

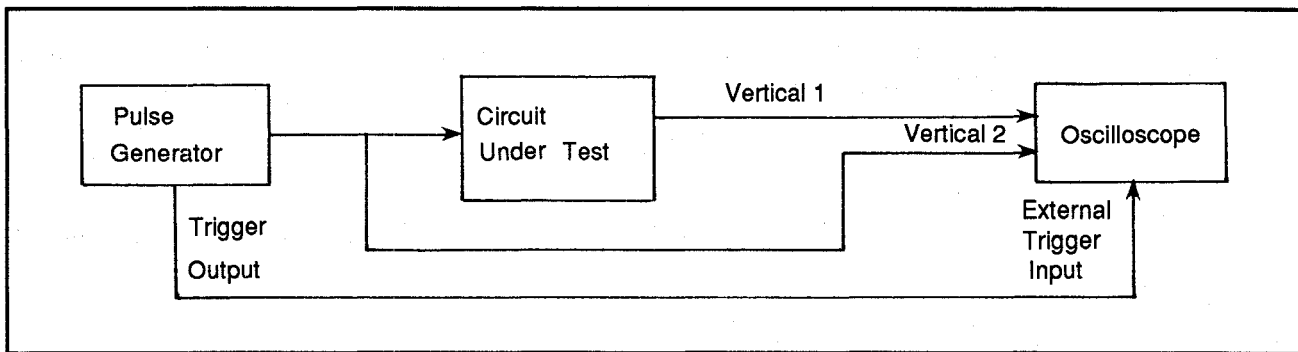


Figure 10: Measuring the rise time

**Phase Measurement**

To measure phase shift between two waveforms, two inputted signals are displayed in alternate mode and overlaid. The sweep speed is set to provide a favorable display to measure  $t$  and  $T$  as shown in Figure 11. The phase difference between the two waveforms can then be calculated by:

$$P = 360 \cdot \frac{t}{T}$$

Another way to measure the phase shift is by using the Lissajous figures shown in Figure 12. Figure 13 shows how to hook the circuit under test to the scope. A straight line is obtained when the phase difference is either 0 degrees or 180 degrees. When the two amplitudes are equal, the angle to the horizon is 45 degrees. The tilt angle  $\theta$  is determined by:

$$\theta = \tan^{-1} \cdot \frac{\text{vertical voltage}}{\text{horizontal voltage}}$$

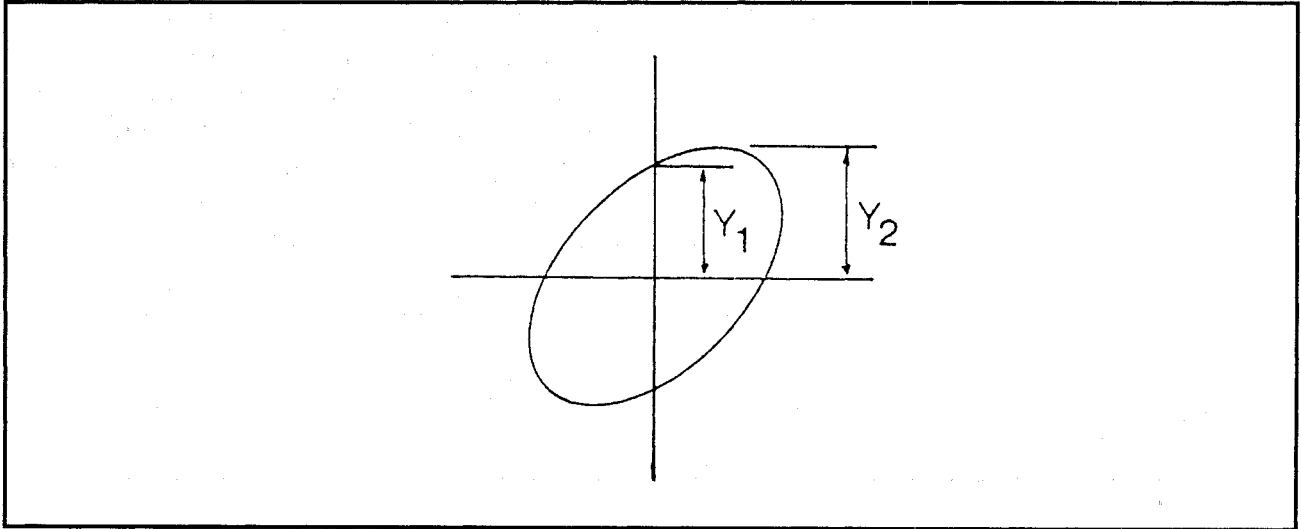


Figure 11: Measuring phase difference

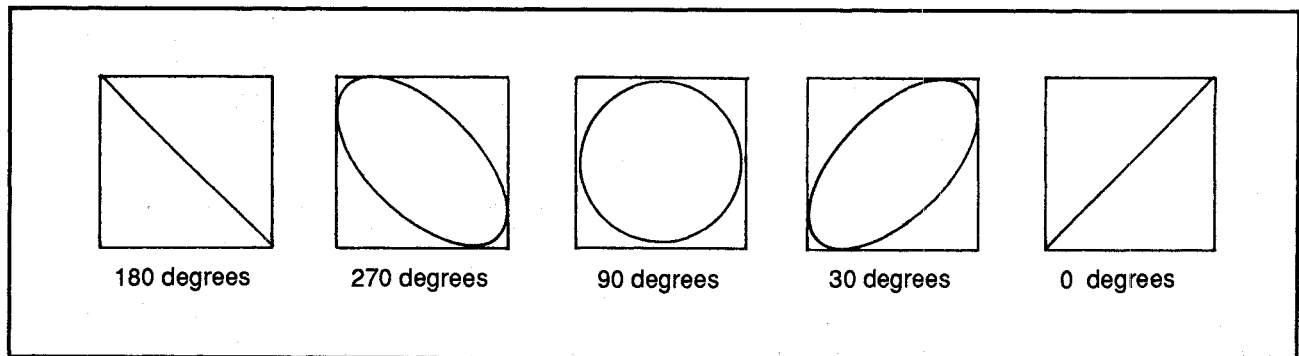
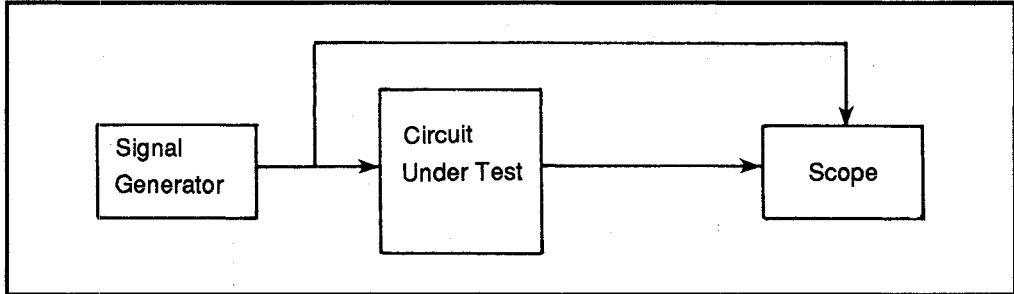


Figure 12: Lissajous figures with the effect of phase shift

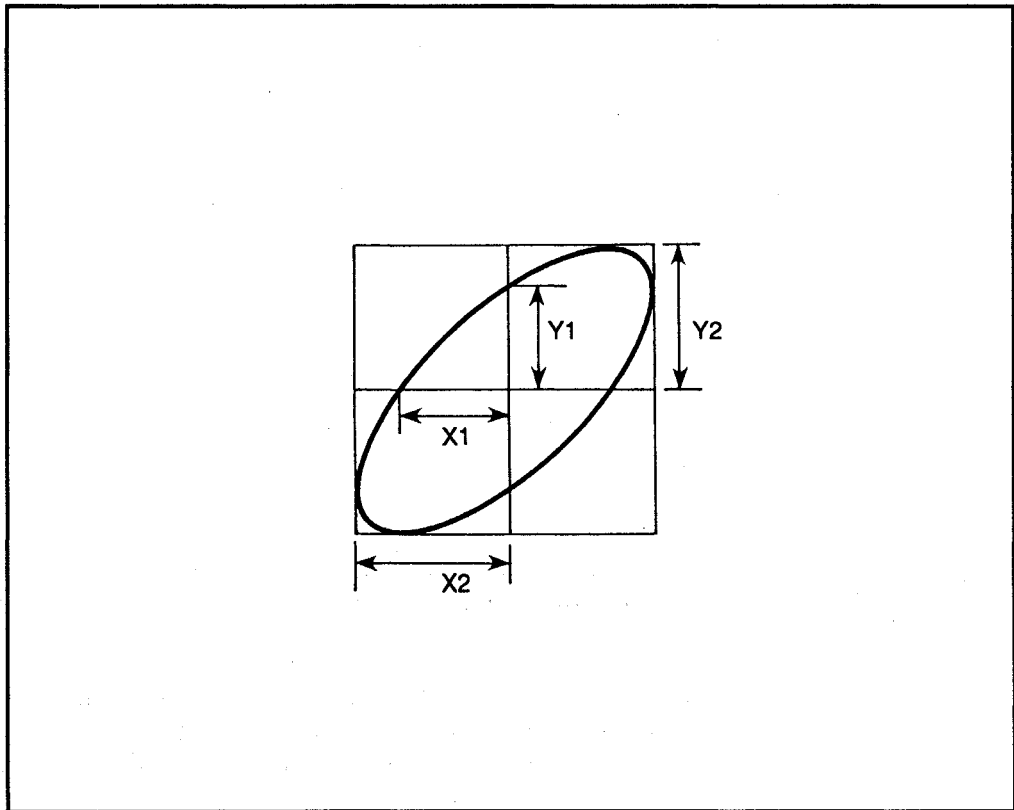
If the horizontal voltage input is higher than the vertical input, then the angle to the horizontal will be less than  $45^\circ$ .

A circle is obtained for either a  $90^\circ$  or  $270^\circ$  phase shift when the amplitudes of the two inputs are the same. If they are not the same, then an ellipse will be produced, with the main axis along the vertical or horizontal depending on which has the greater amplitude.

Figure 14 shows the phase angle between two signals that can be determined. The gains of the horizontal and vertical amplifiers usually will be adjusted so that the ellipse fits into the box shown.



**Figure 13:** Hooking the circuit to the oscilloscope

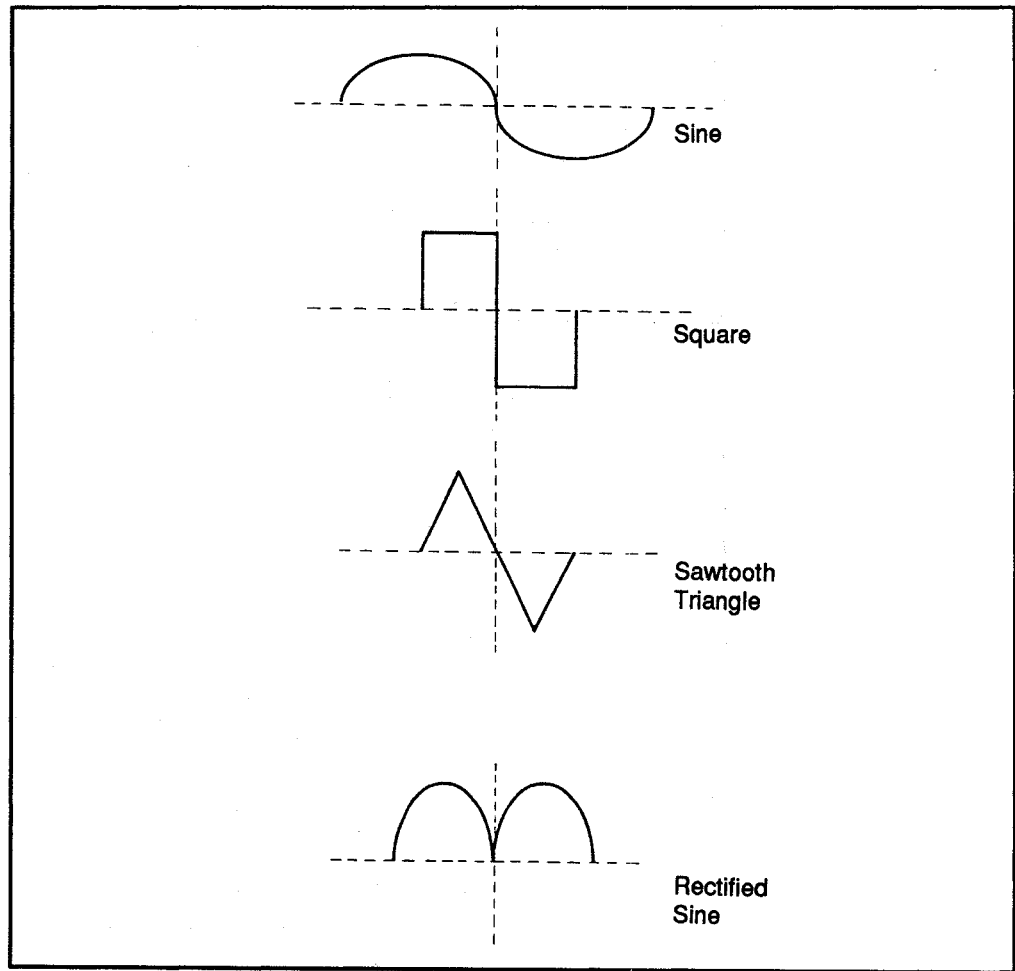


**Figure 14:** Phase angle shift using Lissajous figures

**Waveform  
Analysis**

All waveforms can be classified into either sinusoidal or complex types. Figure 15 shows a sine wave and several complex waveforms. A sine wave will have RMS, peak, and peak-to-peak values. A sine wave's positive and negative peak values are equal, and the peak-to-peak of the wave is double that of the peak value.

Sine waves are characterized by amplitude, phase and frequency. Figure 16 shows



**Figure 15:** Sine wave and miscellaneous complex waveforms

the variation of frequency and amplitude of a sine wave. Figure 17 shows a waveform with leading and lagging voltages. Both waveforms have the same frequency, but different amplitudes. Waveforms that have different frequencies have a fixed-phase relation.

The most basic of the complex waves is the square wave. A square wave is the sum of many sine waves and is illustrated in Figure 18.

The wave contains odd harmonics that are in phase with the fundamental wave and with each other in the typical square waveform.

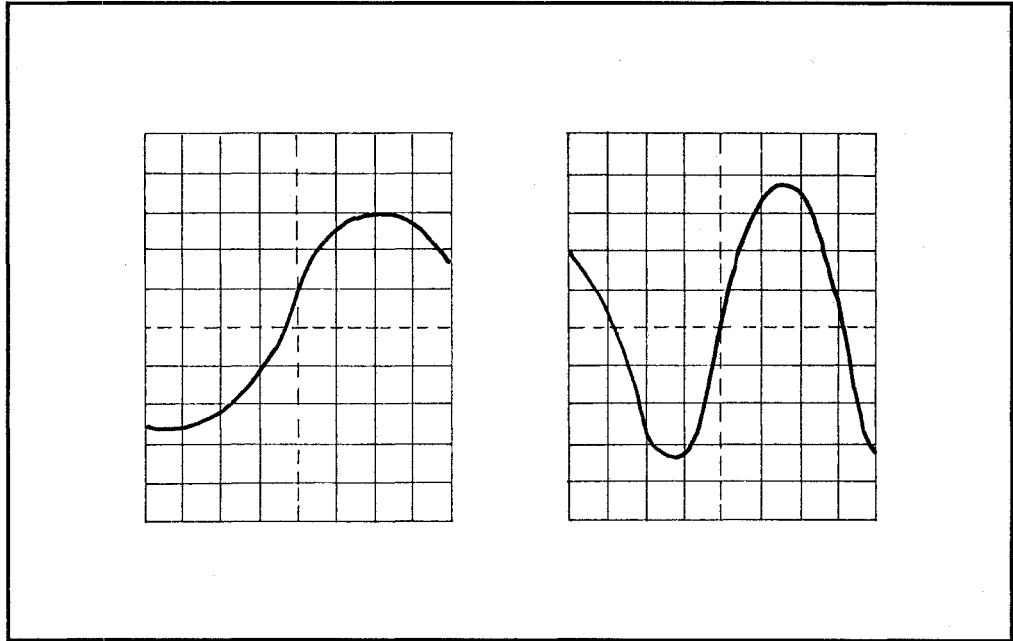


Figure 16: Sine wave with varied frequency and amplitude

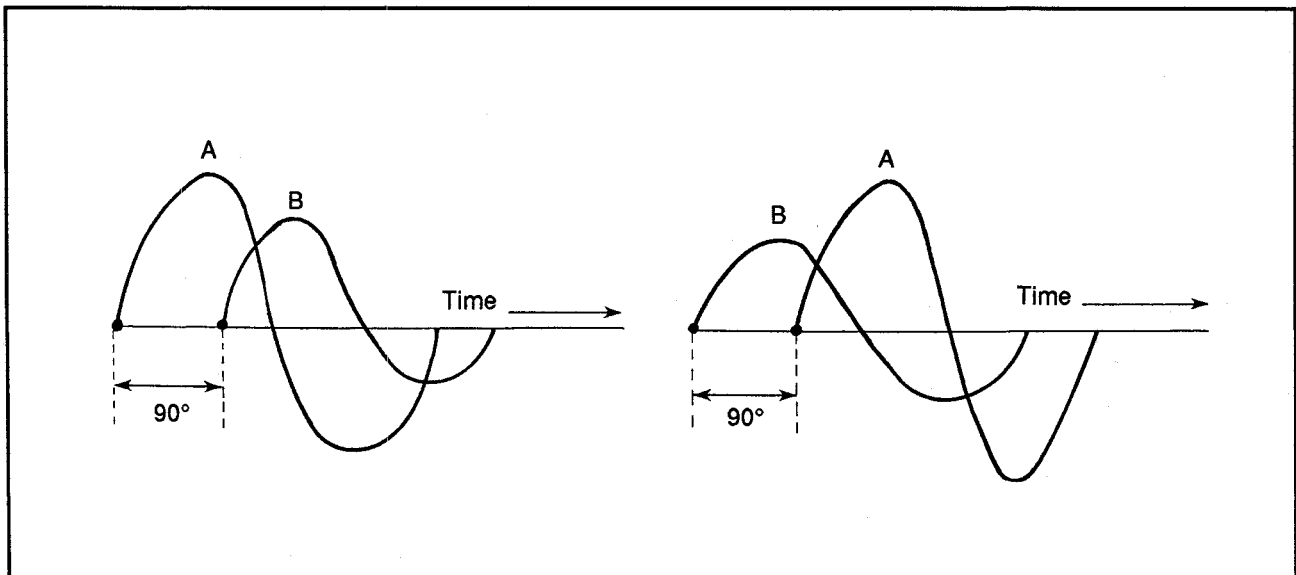


Figure 17a: Waveform with leading and lagging voltages

**4/3**  
Advanced Test  
Equipment

4/3 - O

Oscilloscope

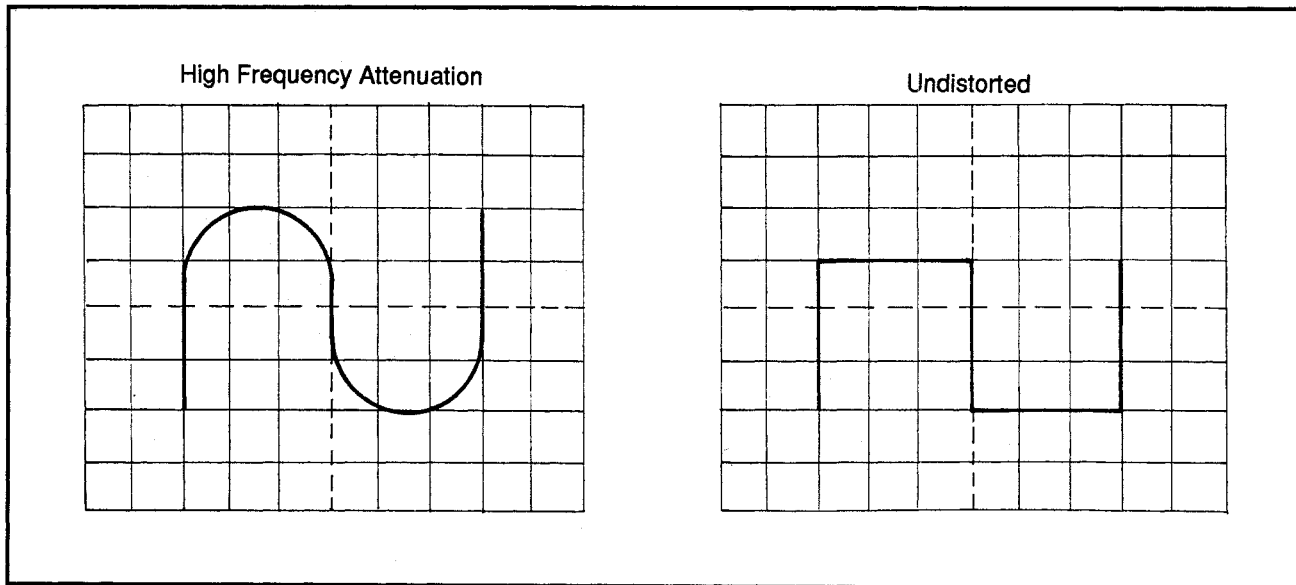


Figure 17b

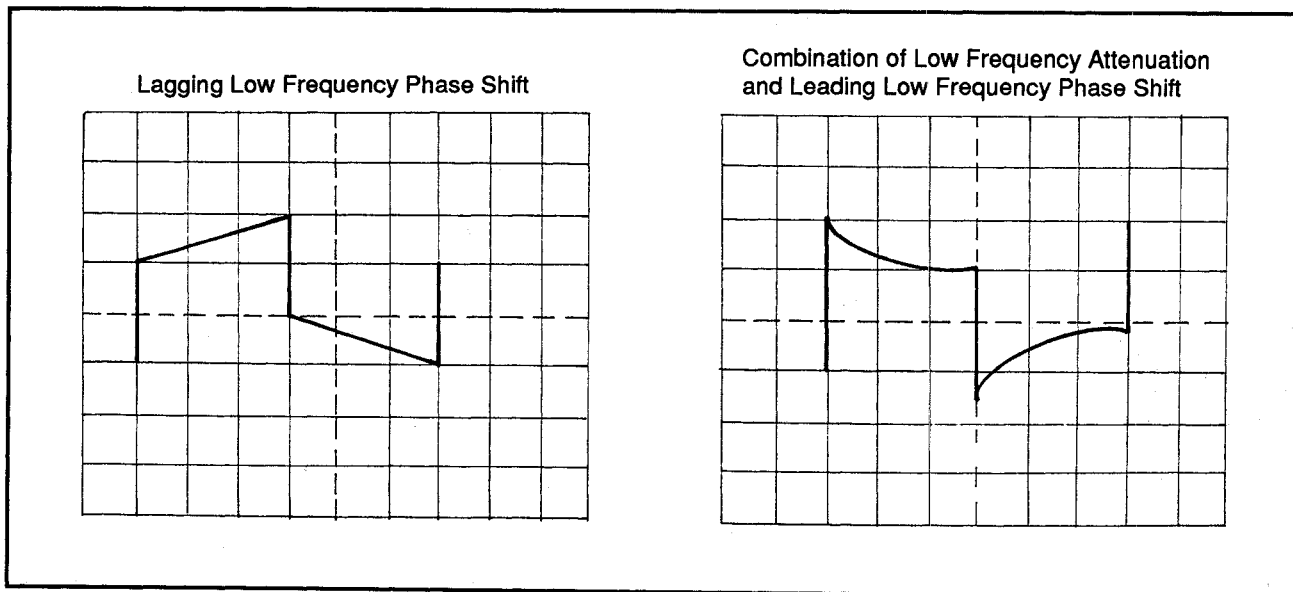


Figure 17c

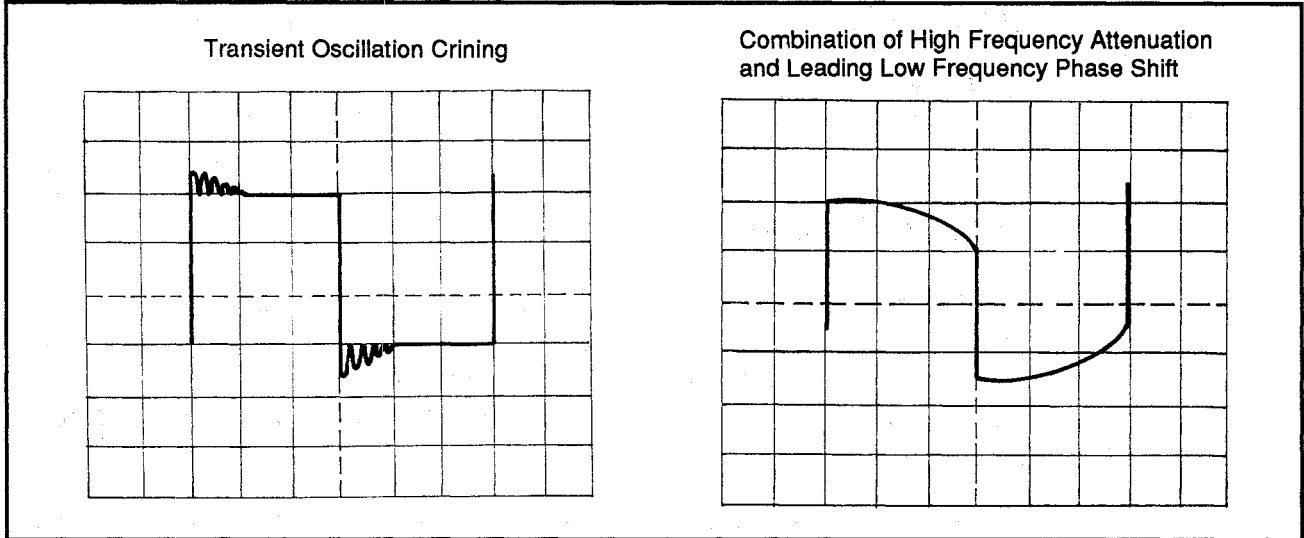


Figure 17d

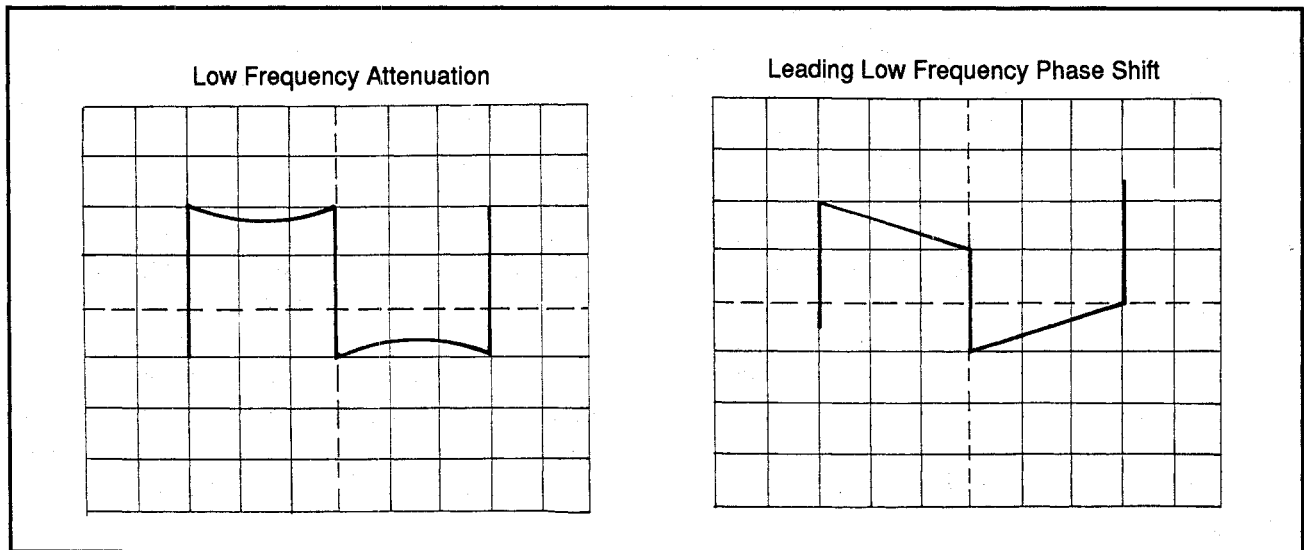


Figure 17e

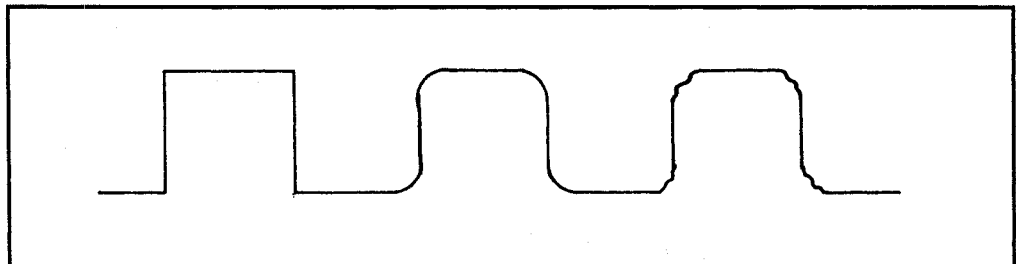


Figure 18: Square wave



## 4/3 - SS Signal Sources

### An Introduction

Devices that generate some form of electrical signal are necessary for a wide variety of applications. These applications may range from measuring the frequency response of amplifiers to the alignment of radio receivers. Signal sources are usually broken into two categories: audio frequency and radio frequency.

Audio frequency generators are usually referred to as low-frequency oscillators. They are capable of producing frequencies from a few hertz to just below 1 MHz. High-frequency oscillators produce frequencies from 100 kHz to 500 MHz.

### Principles of Operation

All oscillators have three sections: an oscillatory circuit, an amplifier, and a feedback circuit. The oscillatory circuit determines the frequency, the amplifier provides the output, and the feedback circuit diverts some of the output back to the input to compensate for losses in the oscillating circuit.

Figure 1 shows a typical block diagram of the basic oscillator principle. Oscillator circuits traditionally used in low-frequency oscillator test equipment are harmonic oscillators, producing sine waves. A harmonic oscillator is an amplifier that obtains its input from its output. In order for oscillation to occur, two criteria must be met. First, the total phase shift caused by the amplifier and the feedback network must be zero at some frequency  $f_0$ . Second, the amplified signal must be just enough to adjust for any loss created by the feedback circuit at  $f_0$ . If these criteria are not met, then the harmonic oscillator will not produce  $f_0$ .

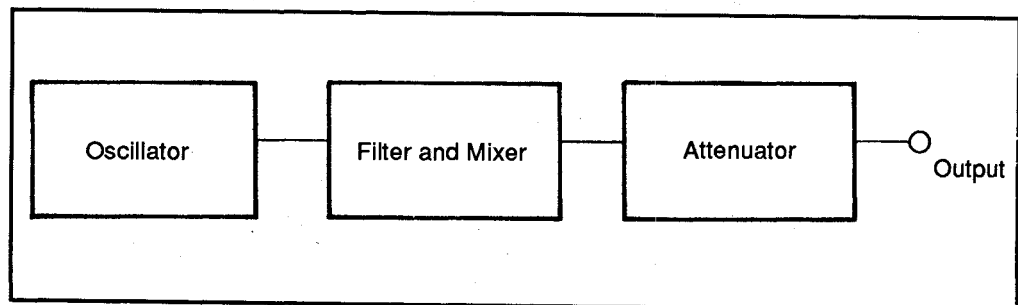


Figure 1: Oscillator block diagram

The average distortion of harmonic oscillator test equipment will be about 0.1 percent, with some equipment distortion as good as 0.001 percent.

Feedback in a harmonic circuit is produced by a resistor-capacitor (R-C) network or a self-inductance capacitance circuit (L-C). Five main types of R-C circuits and L-C circuits are used. R-C circuits include the Wien bridge, bridge-T network and phase-shift oscillators and are used mainly for lower frequencies. L-C circuits include Hartley and Colpitts oscillators and are used in high-frequency ranges.

### R-C Circuits

One of the most used R-C circuits is a Wien bridge oscillator. The Wien has an upper limit of 100 kHz with a simple design and excellent frequency stability with low output distortion.

Figure 2 shows the Wien bridge oscillator circuit. The frequency of the bridge, when balanced, is calculated by:

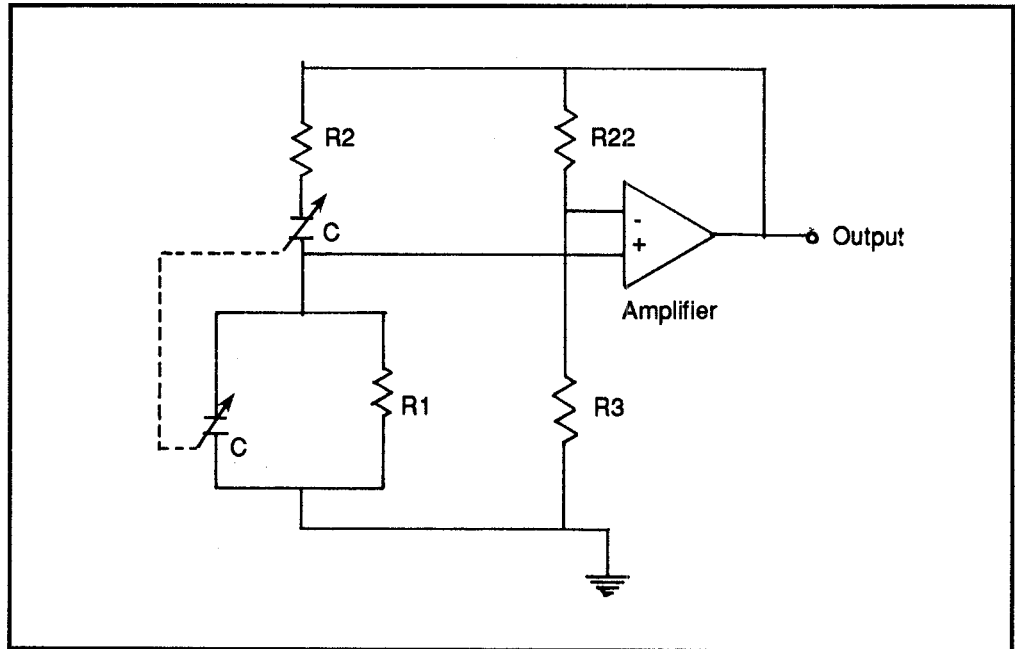
$$f = \frac{1}{2\pi \sqrt{CR}}$$

The Wien bridge oscillator uses the bridge in the feedback circuit of the amplifier. The original bridge is created by R1 and R2. The circuit has a zero phase between input and output so the amplifier has a zero phase shift as well. The circuit has an attenuation of 3, which means the amplifier must have a minimum gain of 3 to work.

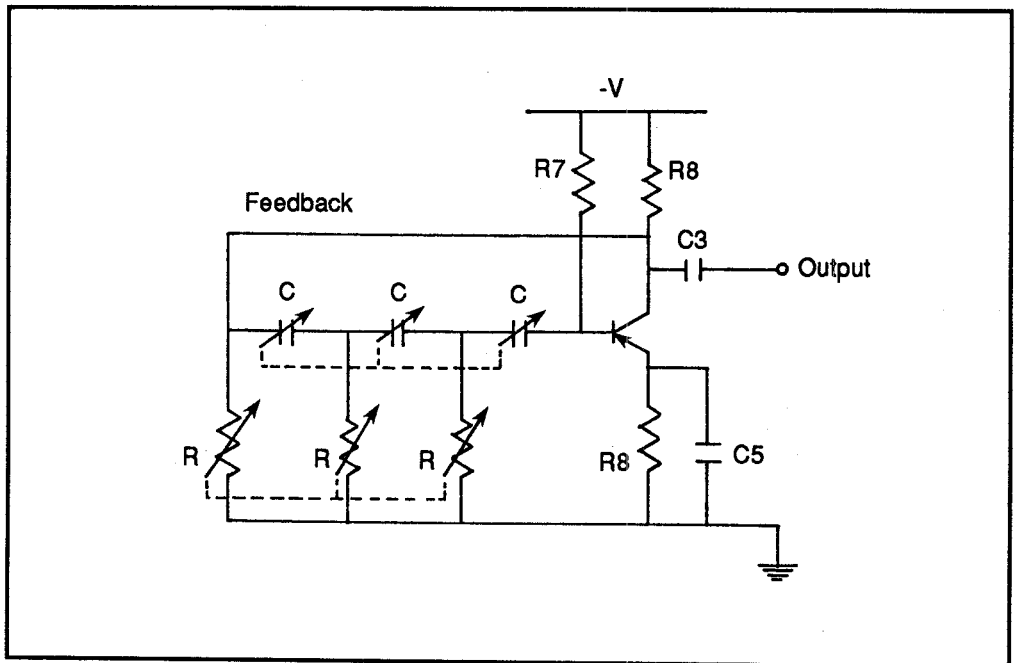
The amplitude of the oscillations in the circuit are created by the products of the amplifier gain (G) and the attenuation ratio (alpha). By changing alpha and by controlling the value of R2 the signal can be changed. Continuously changing C, the frequency of oscillations is varied and stepped through ranges by changing R. The circuit can also be made to compensate automatically for amplitude changes by making R2 have a positive temperature coefficient of resistance.

Figure 3 shows a phase shift oscillator circuit. It is designed to work over a very wide frequency range from a few hertz to several kilohertz. In this circuit a single stage transistor is used to create a phase shift of 180 degrees. The three stages of the R-C must then create a further 180-degree shift, each giving a 60-degree shift. This circuit's frequency can be computed by:

$$f = \frac{\sqrt{6}}{2\pi RC}$$



**Figure 2:** Wien bridge oscillator



**Figure 3:** Phase-shift oscillation circuit

The feedback for this circuit is 29, which means the amplifier must have a gain at least equivalent to this value.

## L-C Circuits

L-C circuits, often referred to as Hartley or Colpitts oscillators, produce the desired sine wave frequency for use in high-frequency ranges. An L-C type of circuit is not suitable for low frequencies because they would require very large values of inductance. The resonant frequency ( $f$ ) of an L-C is computed by:

$$f = \frac{1}{2\pi \sqrt{LC}}$$

Figure 4 shows a typical Hartley oscillator circuit. Capacitor  $C$  shunts the tapped inductor  $L$  which creates the L-C tank. Feedback is provided by an R-C circuit. In this example the R-C output is coupled. The transistor provided a 180-degree phase shift. An additional 180-degree shift between output and feedback is created by the tapping on the inductor  $L$ . Capacitance  $C$  is adjusted to vary the frequency of the oscillation.

Figure 5 shows a typical Colpitts oscillator circuit. In this type, a transformer is used in a coupled output. It is very similar to the Hartley oscillator circuit but the Colpitts has two capacitors that replace the tapped inductor.

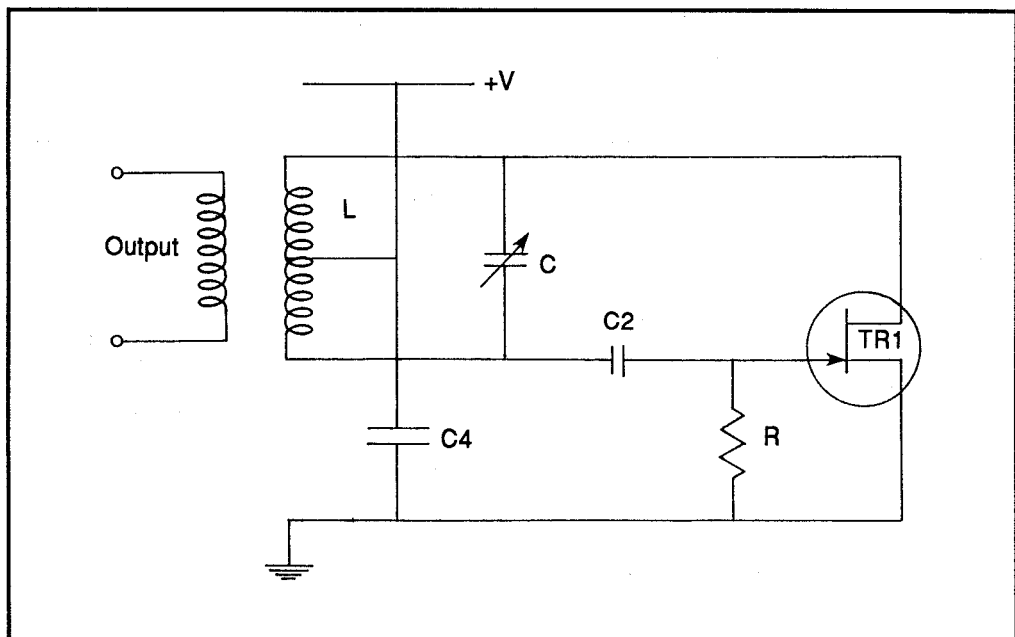


Figure 4: Hartley oscillator circuit

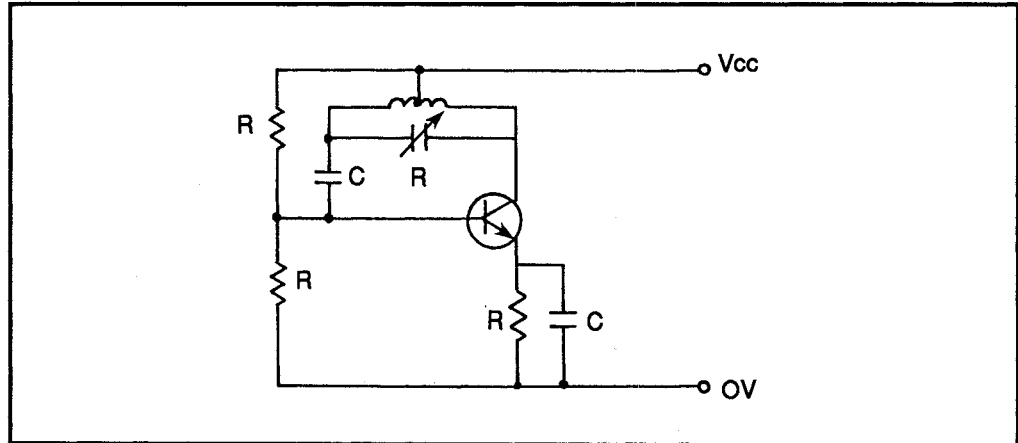


Figure 5: Colpitts oscillator circuit

## Pulse and Square Wave

Pulse circuits are either passive or active. Passive circuits shape an input waveform, like a sine wave, to generate a pulse output. Active circuits are used in blocking oscillators or multivibrators to give an output pulse for every two inputs.

Figure 7 shows a circuit that is a blocking oscillator. It drives a transistor (TR1) in and out of saturation which creates a series of pulses. This creates a 180-degree phase shift and the transformer then produces an additional 180-degree phase shift

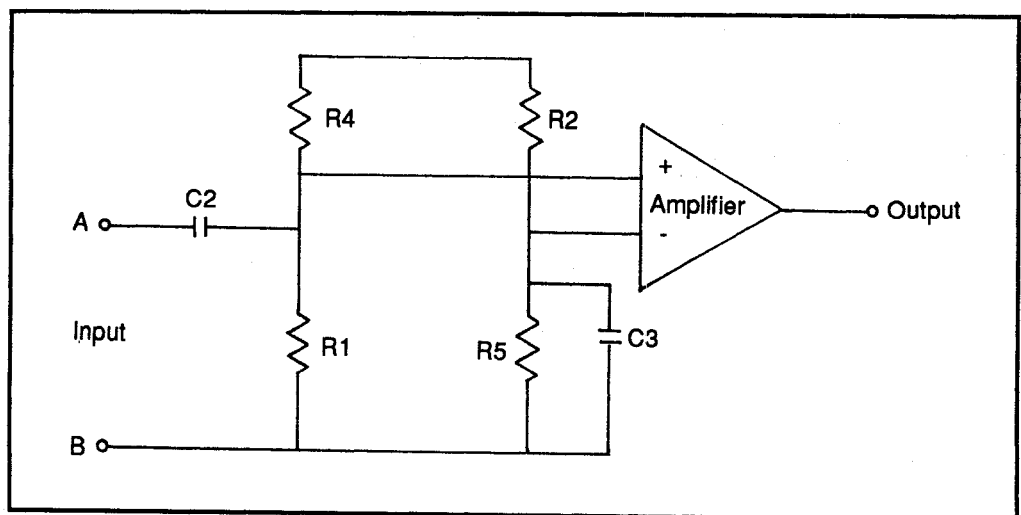
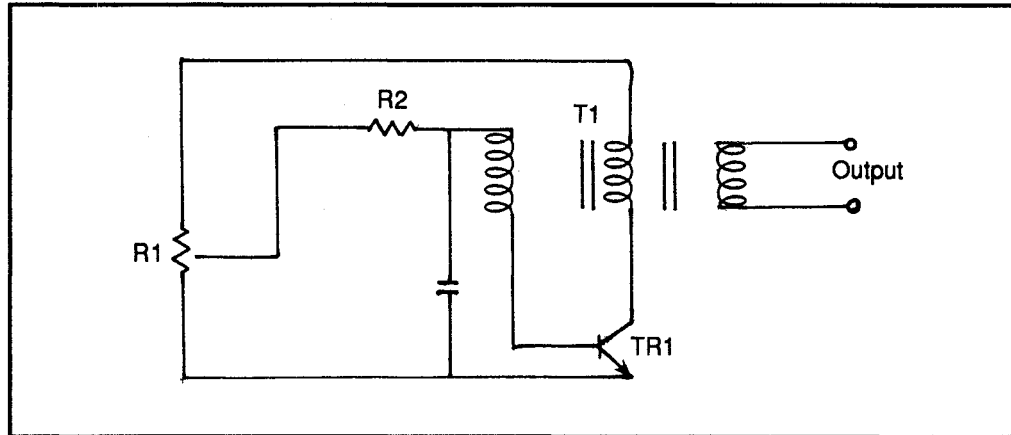


Figure 6: Pulse train circuit



**Figure 7:** Blocking oscillator circuit

to produce a circuit run cleanly with continuous oscillations. R1 is used to change the frequency of the oscillator. The pulse width is figured by the characteristics of the transformer. The frequency of this circuit is computed by:

$$f = \frac{(N+1)}{RC}$$

Multivibrators come in three types: astable, bistable, and monostable. Astable is a free-running multivibrator that produces a string of pulses. By adjusting the timing resistors and capacitors, you can change the pulse widths and periods of the circuit. Bistable are flip-flops that create an output pulse for every two input trigger signals, and monostable give a timed pulse out for a trigger input.

## Signal-Generating Devices

Devices that produce high-frequency signals are usually called signal generators. They produce RF frequency signals using the Hartley and Colpitts oscillator circuits. Signal generating equipment uses the previously mentioned circuits to produce sine, pulse and square waveforms.

Signal generators usually produce a fixed-frequency sine wave that can be frequency or amplitude modulated by another signal. They can be instruments covering the range from 0.001 Hz to 50 GHz. Most signal generators fall somewhere in this range but will not cover the entire range. The signal generator circuit has a low output distortion. This is achieved by varying the voltage across a variable capacitance diode in the tuning circuit, in turn, creating frequency modulation.

Manual or automatic methods can be used to keep the output amplitude constant during frequency modulation. To create this constant, the supply voltage to the oscillator is varied. Problems occurring from this method are phase modulation and a suitable small modulation depth of up to about 50 percent.

By using the heterodyne principle, as shown in Figure 8, you can get a continuously variable, wide frequency range outputted from a single device. The stability of the frequency will be poor, especially at lower frequencies and will have a large amount of noise and false signals outputted. Figure 8 shows that the output is a different frequency, and a slight change in one of the frequencies when they are close will cause a considerable amount of drift. Multiplier and divider techniques are used to extend the frequency range of a signal generator.

In a multiplier generator (Figure 9), the output of a nonvariable frequency oscillator is fed through a series of tuned multipliers. Each has a nonlinear amplifier that produces harmonics. Each stage's output is fed to a tuned filter which selects the high-frequency output. To achieve differences in amplitude

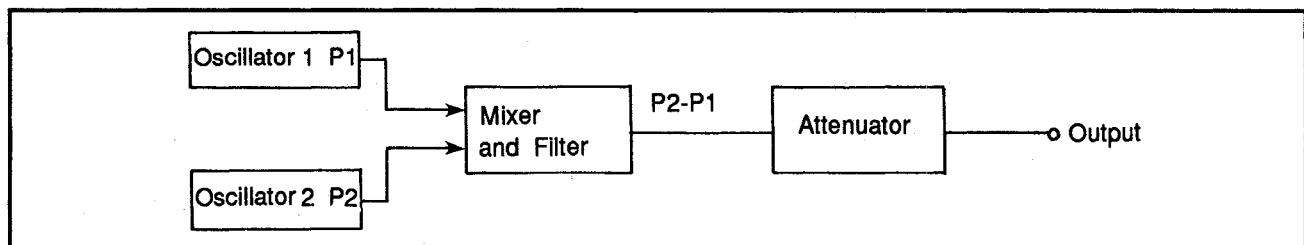


Figure 8: Heterodyne

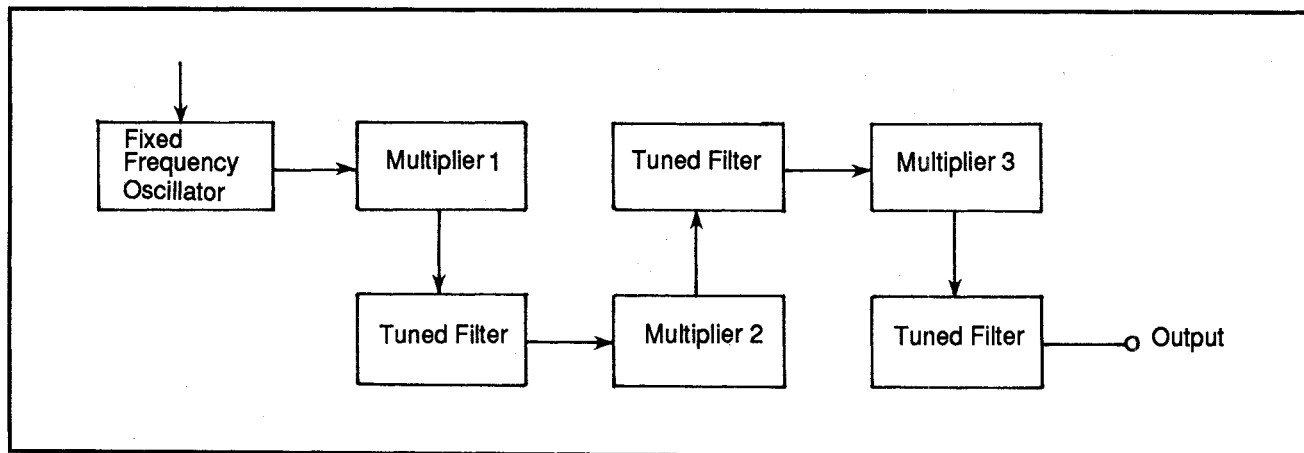


Figure 9: Frequency multiplier

modulation, the supply voltage to the last stage is varied. Multipliers tend to produce a great deal of false signal around the desired frequency.

The divider signal generator uses a high-frequency main oscillator. The output is divided down by a series of electronic stages, and then the output from the stages, being square waves, is filtered and changed to sine waveforms. Frequency modulation is sent to the main oscillator when needed. Diode modulators produce the amplitude modulation in the output amplifier. There are no false signals produced below the required frequency.

### Sweep-Frequency Generator

The sweep-frequency generator is a special type of signal generator from which the output frequency is cyclically swept through a range of frequencies. This device can be used with an oscilloscope, or as a stand-alone unit. Figure 10 shows the block diagram of a sweep generator using a heterodyne-frequency generator. Sweep times can be changed by an adjustable, triangular or sawtooth time-base adjustment. This gives sweep times in the range from 10 ms to more than 100 s.

A sweep-frequency generator usually covers frequencies over three bands: 0.001 Hz to 100 kHz (low frequency to audio), 100 kHz to 1500 MHz (RF range), and 1 to 200 GHz (the microwave range). Two methods are used to set the sweep frequency range. They are the stop-start and the delta-frequency methods. In the stop-start mode, the stop and start frequencies are set from a front panel. This method is used for a wide sweep width and the unit sweeps between the selected range.

In the delta frequency mode, the center frequency and the maximum coverage about this frequency are set on the front panel. This method is used for narrow sweep widths.

Three approaches can be used to cover a wide band of sweep frequencies in a single unit. The first approach is to manually switch between different frequency oscillators. The second is stacked switching in which different bands are automatically selected by electronic switches allowing the ability to sweep the entire range of the instrument as if it were one continuous band. The third is a heterodyne control. In this method, a continuous band is created by two high frequencies mixed and output at a lower difference frequency.

The output level control is used to keep the output amplitude from varying from the value set on the front panel. In the sweep-frequency generator, there is usually some kind of RF detector monitor that monitors the RF amplitude of the output. The necessary amplitude is compared with a signal that should agree with



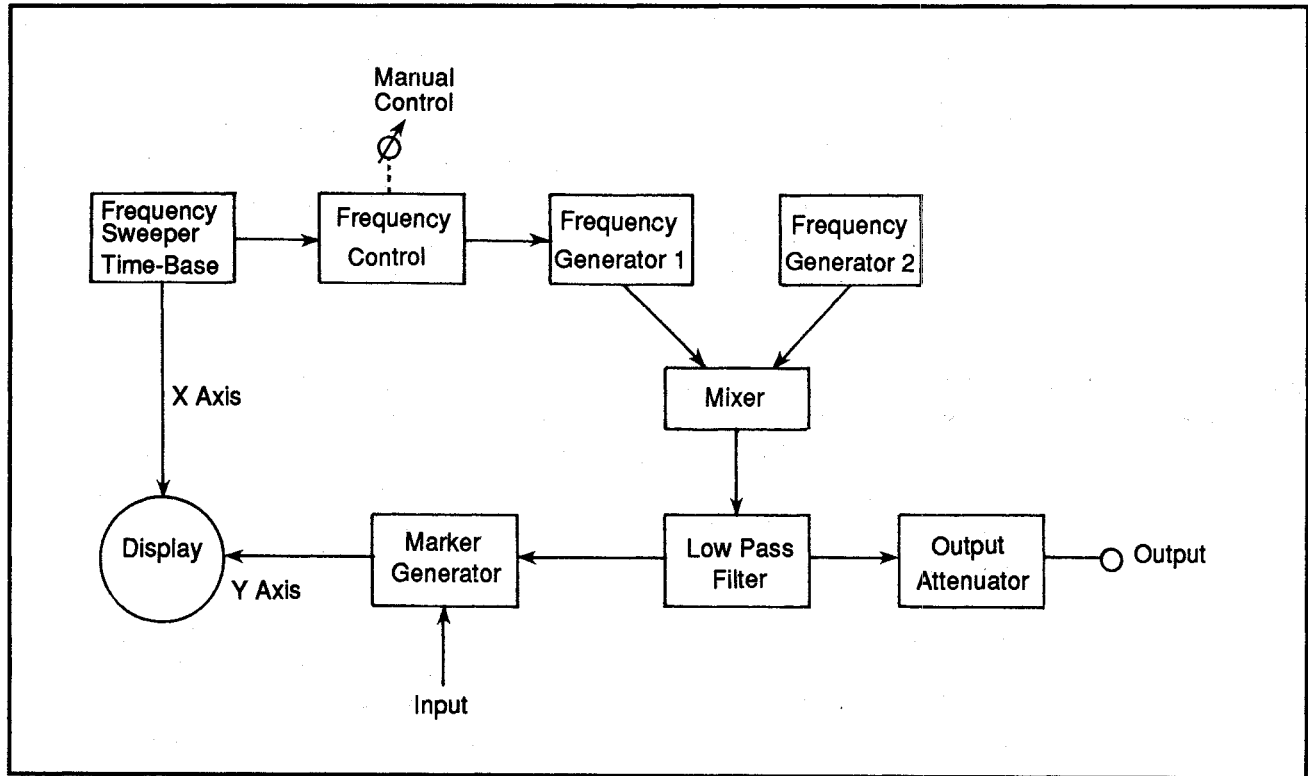


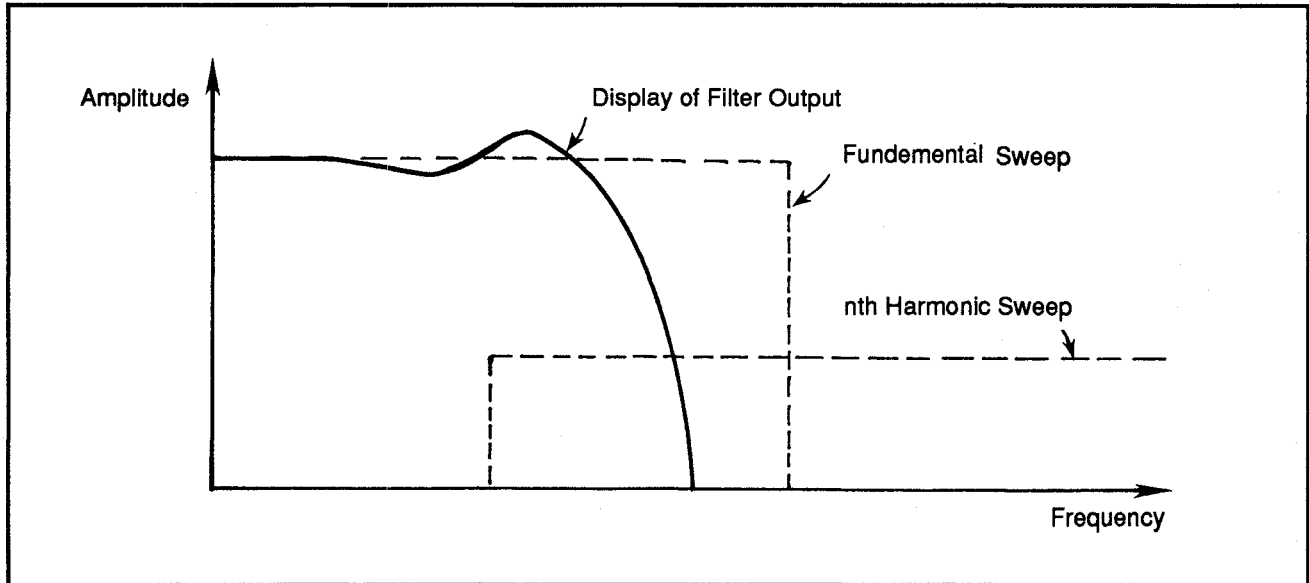
Figure 10: Block diagram of a sweep generator

it. This error is then fed back to an electronic attenuator circuit which keeps the output at a constant level.

### Sweep Error

Flaws in the sweep-frequency generator output can cause several errors. A harmonic produced in the frequency source will be swept along with the main signal, but at a faster rate. Figure 11 shows the effect of sweep-generator harmonics. It shows how an  $N$ th value will be swept at  $n$  times the rate of the main signal. This would most certainly create a change in the instrument's response. A bump is created when the  $n$ th harmonic is present. From this  $n$ th harmonic, several overlapping harmonics will be created or a series of bumps will occur. Usually the second and third harmonics will cause the most problems since the higher harmonics are at a much lower amplitude.

The change in amplitude and accuracy of the output is another important concern. The amplitude varies with the sweep rate and has less time to work at faster sweep rates. Sweeping at the lowest rate allowable by the generator can be a good method to minimize errors.



**Figure 11:** The effect of sweep generation harmonics

Many sweep-frequency generators can change in reading from the logarithmic display to the linear display. Output of a sweeper is not linear to begin with and if large changes in level are being observed, the logarithmic display will generally be more accurate. If small changes are all that will be observed, then the linear display will be best. Display readings are usually not accurate enough to interpret the frequency being displayed.

To help improve this, put a series of accurately known frequency markers onto the screen for reference. To create the marker frequencies, a unit may pass the output from a stable crystal oscillator through a harmonic generator. This creates a series of narrow pulses that are spaced at harmonic intervals. These pulses are mixed with a sample of the RF output from the sweeper. The mixer creates a series of low difference frequency output bursts as the sweeper frequency approaches and passes through each harmonic frequency. These bursts are shaped and amplified, and are then combined with the signal received back from the device under test. The results are then displayed. This is a composite picture of the device being tested and the calibration marker's characteristics.

### Frequency Generators

Free-running synthesizers and frequency synthesizers are two types of generators. A free-running unit has an output that can be tuned continuously over a frequency range either by electronic or mechanical methods. These are the types discussed thus far in the manual. Free-running units have a good overall performance, but their accuracy and stability are poor.

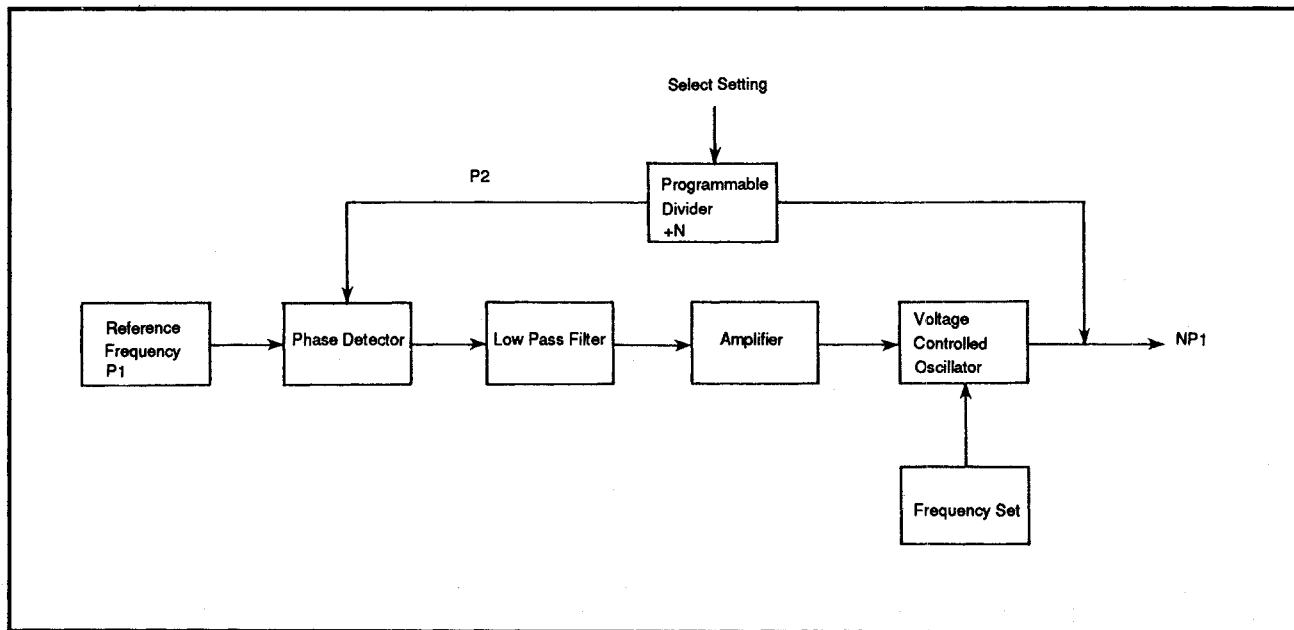


Figure 12: Basic indirect multiloop frequency synthesizer

Frequency synthesizers create their output from a fixed frequency created from a highly stable oscillator, and cover the range in a series of steps. These devices come in two types: direct and indirect.

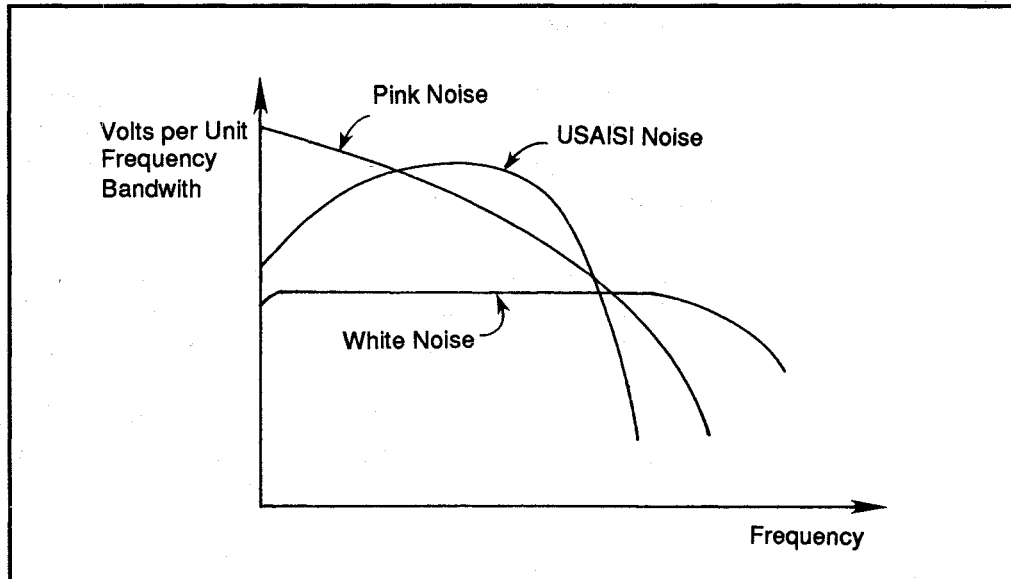
A direct frequency synthesizer uses a stable crystal oscillator, harmonic multipliers and mixers to create the range of different frequency outputs.

An indirect frequency synthesizer uses a phase-locked loop to give an output that is a fraction of a stable crystal oscillator. Figure 12 shows the basic indirect multiloop frequency synthesizer. The multiloop frequency synthesizer covers ranges from 10 kHz to 3000 MHz and from 0.01 GHz to 30 GHz.

### Random Noise Generators

Random-noise generators create a signal output that has an instantaneous amplitude that varies randomly. This type of generator can be used for frequencies from low audio to microwave. They could be used for testing radar and radio for signal reception in the presence of noise, or intermodulation and crosstalk tests in communication systems.

When testing with random-noise generators, one is usually interested in noise that has a bandwidth greater than that of the circuit under test. Within the noise-power spectrum this frequency range can be (alone) one of three possible curves as show in Figure 13. White noise has a constant spectral density from 20 Hz to



**Figure 13:** Three possible curves of the noise-power spectrum

25 kHz. Pink noise can be found at higher and lower frequencies because its amplitude varies inversely as the square root of the frequency. Its spectrum is close to that of red light and is used in bandwidth analysis. USAISI noise is about equal to the energy dispersal of music and speech frequencies. This is sometimes used for testing audio systems.

Random-noise generators are prone to long-term variations which may cause an unpredictable power spectrum. An alternative to a random-noise generator is a pseudo-random noise generator. The advantage of using a pseudo-random generator is that the patterns can be repeated many times.

### Function Generators

Function generators can produce several different waveforms from the same instrument. These waveforms are usually sine, square and triangular waves over a frequency range of 1 Hz to 50 MHz. A function generator's performance is usually less than that of a dedicated instrument.

Function generators are a good test unit to use when troubleshooting stereo amplifiers. Unbalanced channels, poor frequency response, distortion and other problems can be difficult to locate in stereo equipment.

With the aid of a function generator and a wide-band triggered-sweep oscilloscope, you can easily check from one test point to the next, comparing signal gains and comparing the right and left channels.

Figure 14 shows the basic parts of a function generator.

Another type of function generator is the arbitrary waveform generator. In this type of device, you can store and generate a user-created waveform. Arbitrary waveform generators are limited to low-frequency ranges, but are still very flexible as test equipment.

In this type of device, a waveform is stored as a series of points on a grid, in RAM. The 1000 time points and 4000 amplitude points of a typical instrument are then read as a waveform which is created with linear interpolation between the points.

An output frequency of 5 kHz would be available in an arbitrary waveform generator. This display can be varied, with the greater number of points producing a higher resolution and slower operation.

A more accurate method of arbitrary waveform generation is to use sequences of vectors which are then used as tangents to create a waveform. An average system

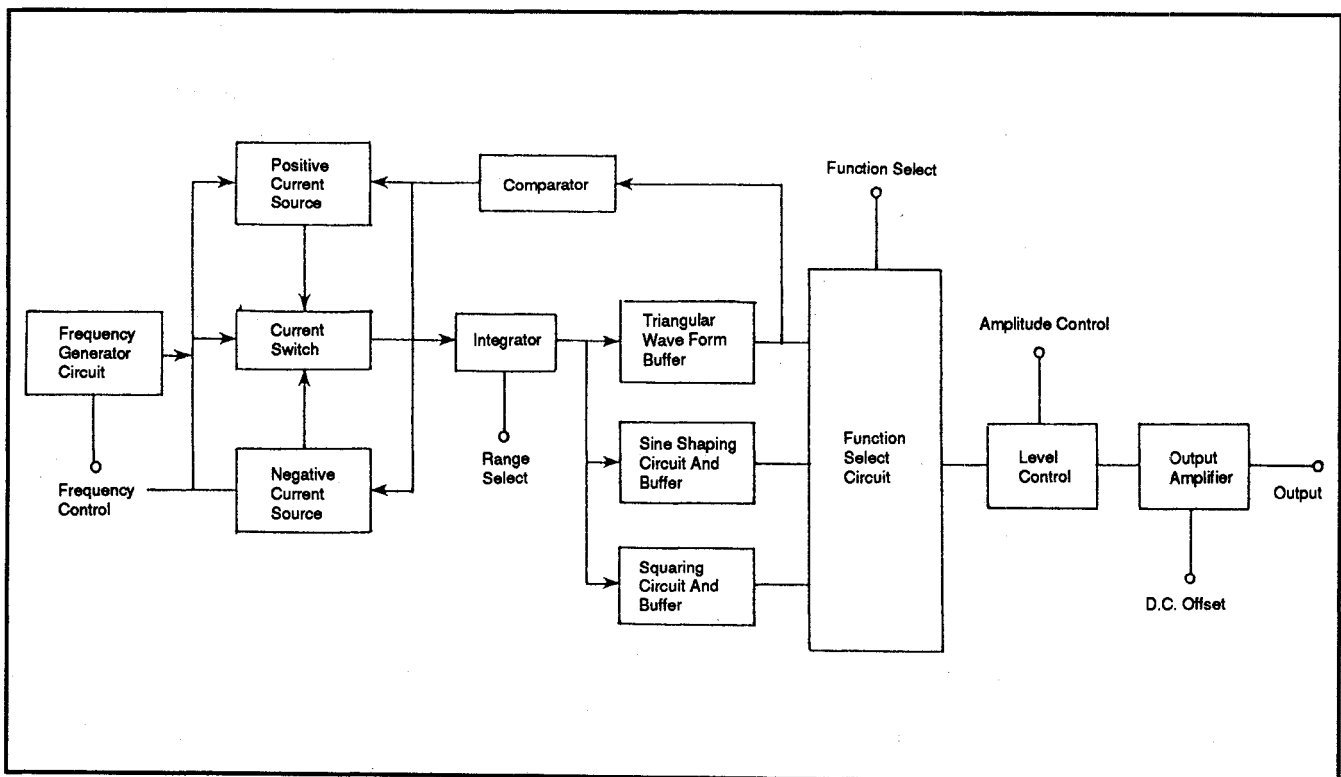


Figure 14: Basic parts of a function generator

would use around 200 vectors during waveform generation at a minimum interval of about 0.1 ms producing a maximum output of about 1 kHz. This method is much slower than the arbitrary system since the vector needs to be created as a separate ramp.

Function generators operate in several different modes—gate, N-burns, triggered, phase-locked, modulation, and sweep.

The gated method produces a continuous output as long as the gated input is above a certain value. In the N-burns method, N is created at each trigger (where N is the number of cycles selected by the user). Triggered mode produces one cycle of output at each trigger. In the phase-locked mode, two or more devices are locked together; that is, their outputs are phase-shifted to match each other. In modulation mode, the output of one generator is modulated by another using AM/FM phase modulation.

## Audio Applications

Using a square-wave generator and an oscilloscope, you can test and display various distortions in electronic audio amplifiers. Figure 15 shows an audio generator capable of producing sine, square, and triangle waveforms. This particular unit has a range from 1 Hz to 250 MHz.

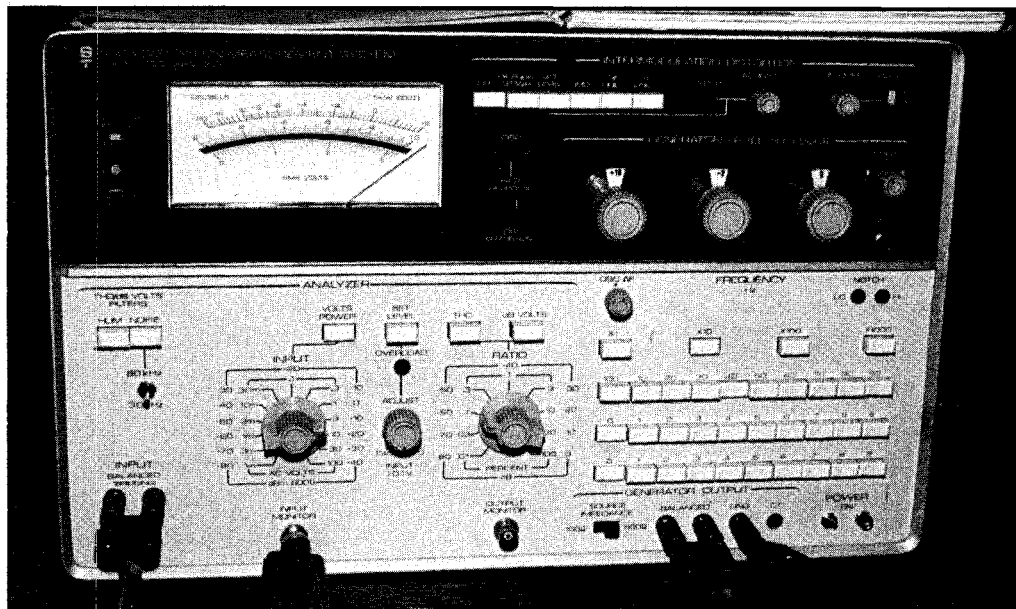


Figure 15: Audio generator

By using a square wave you can measure the selected signal, for example 1 kHz up to the 15th or higher harmonic. Sine-wave generators are best for this because of the large number of odd harmonics. Square-wave testing becomes more perceptible when you see that many audio amplifiers must pass several different frequencies simultaneously.

Checking the actual response of an amplifier requires the use of a sine-wave signal, especially in limited bandwidth amplifiers. Square-wave signals will not only provide a quick check of amplifier performance, but will also show some distortions that may not be apparent with sine-wave testing. In either case, you must know the specifications for the circuit being tested.

To begin a square wave test, connect the output of the generator to the input of the amplifier being tested. You will usually use the DC component when testing, but the AC mode may be used at frequencies below 5 Hz without problems. Next connect the vertical test probe of the scope to the output of the amplifier. An example of such a hookup is shown in Figure 16.

Adjust the vertical gain controls to a good viewing height. The internal sync should be used as well as auto triggering. The sweep controls should be set for one cycle of square-wave viewing.

The short rise time and the rapid drop at the end of the half cycle occur because of the in-phase sum of all the medium- and high-frequency sine-wave components. The wave should look similar to the one shown in Figure 17.

When viewing a wide-band audio amplifier with square-wave checking, there will be many distortion characteristics of the circuit. Distortions can be broken

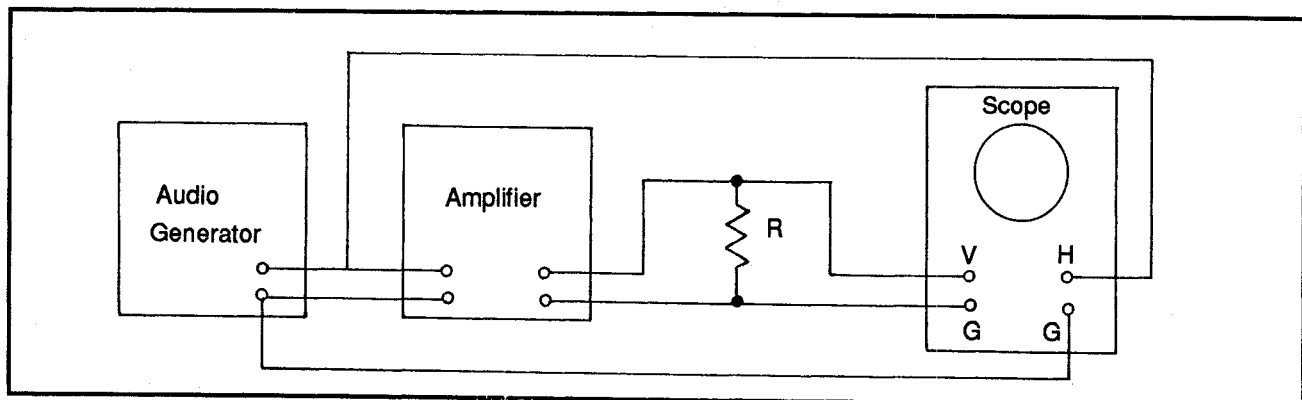
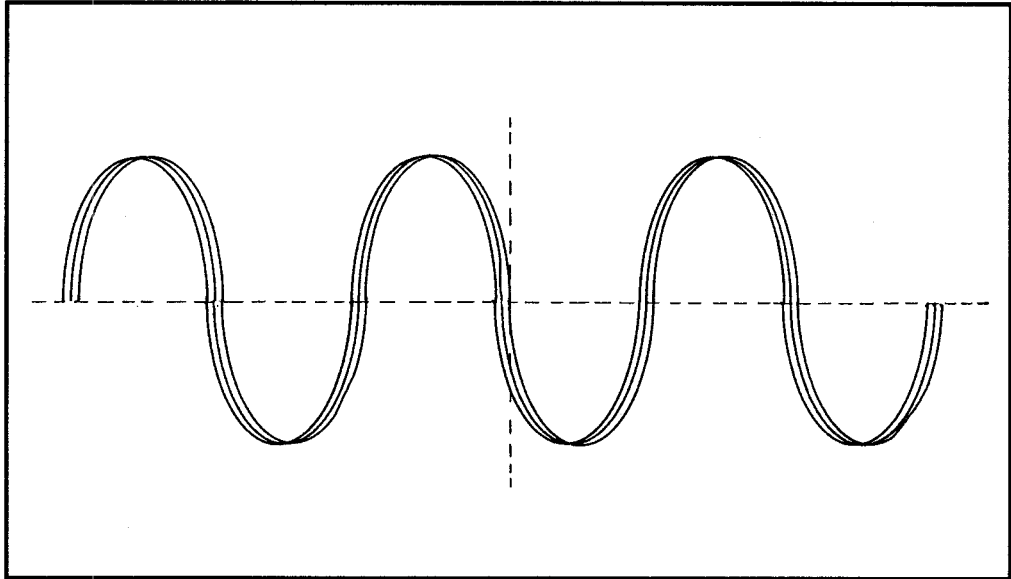
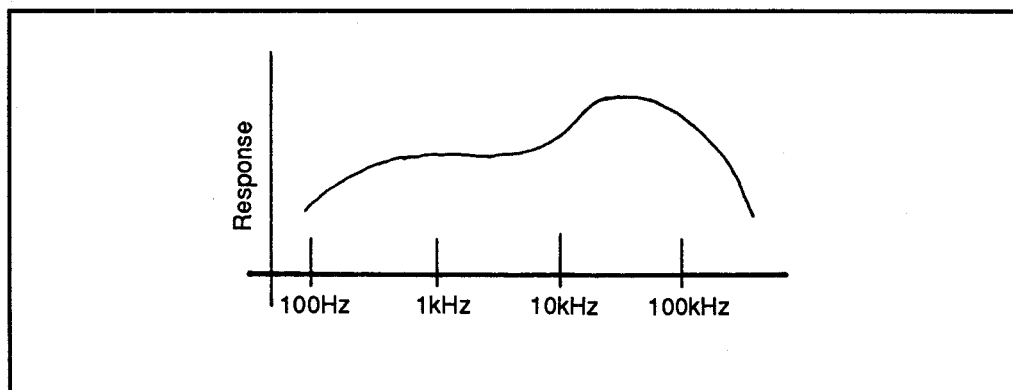


Figure 16: A typical audio generator hookup

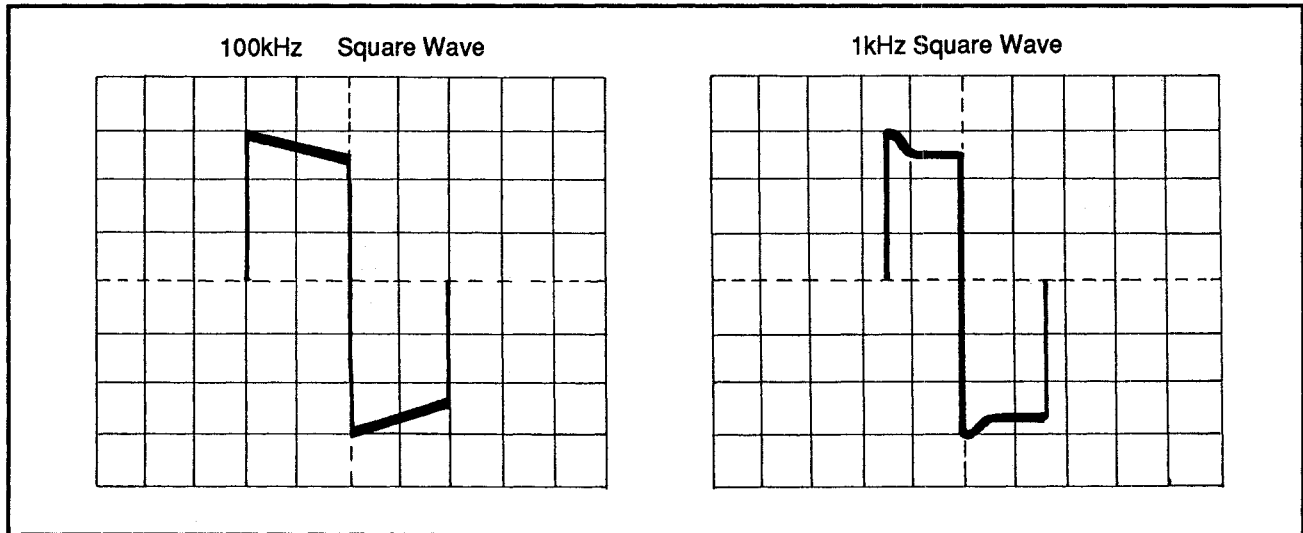
**Figure 17:** Sine wave with problem

into three categories: frequency distortion (the change from the normal amplitude in a complex waveform); delay or phase distortion (produced by one or more components of a complex waveform phase shifted); and nonlinear distortion (the change in the wave shape created by sending the wave shape into nonlinear devices).

When signal testing, there will be a poor response at low and high ends (Figure 18). Different signal inputs of 100 Hz and 1 kHz are shown in Figure 19. The 100 Hz square wave shows that this wave has a good medium-frequency response but a poor low-frequency response. At 1 kHz the frequency now has

**Figure 18:** High and low end distortion curve



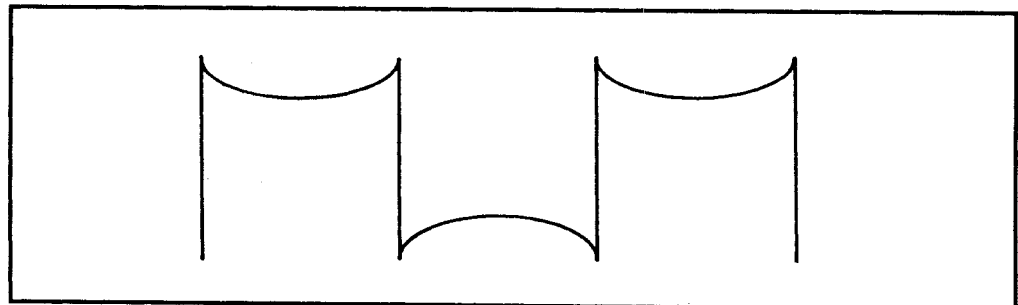


**Figure 19:** 100 Hz and 1 kHz square wave checks

a good frequency response in the 1 kHz to 4 kHz range, but shows an overcompensation by the sharp rise at the top of the leading edge of the square wave. This peak is in the higher 10 kHz region.

Figure 18 also shows that a 100 Hz square wave signal can be used to check components up to about 4 kHz, and above that will require a square wave at about 1 kHz.

If the amplifier under test depressed the low-frequency components in the square wave, you would see a wave like the one of Figure 20. What happens is a phase shift of 180 degrees when there is a reduction in amplitude to a component. That is why there is the strong tilt, or bump of Figure 20(b). A bump indicates that a high-frequency overshoot is being created by a rising amplifier responding at higher frequencies.



**Figure 20:** Waveform with depressed low frequency

If there is an abnormal rise in the amplitude response at high frequencies, the high-frequency components in the square wave will be amplified unequally causing the bump. The tilted square wave is caused by the strong influence of the phase-shifted third harmonic. Any shift in phase will cause tilting.

Figure 21 shows a low frequency that has been tilted by lowering the amplitude and phase shifting. Low-frequency distortion is noticeable because of the change in the shape of the flat top portion of a square wave.

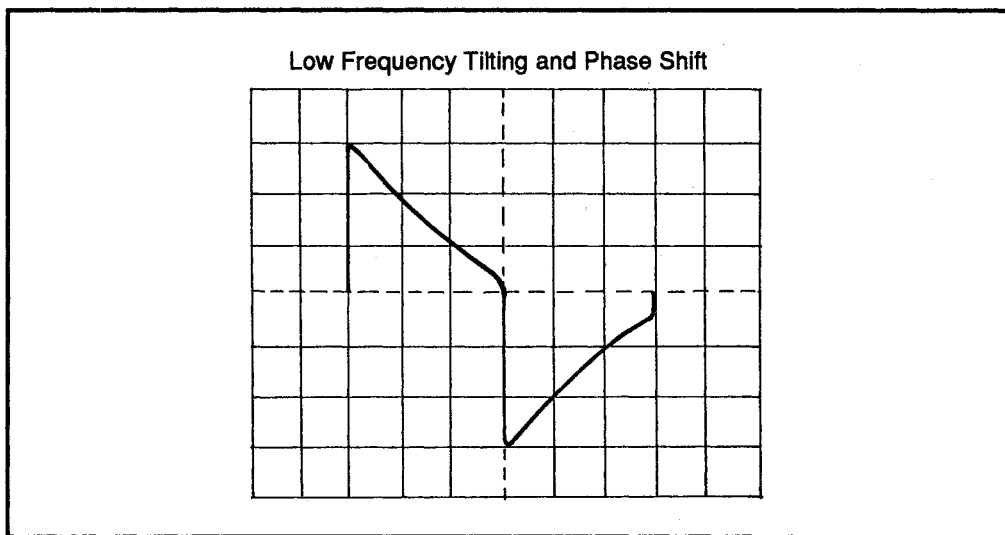


Figure 21: Low frequency tilting

# Section 5

## Video

### Table of Contents

#### 5/Cam *Camcorder*

5/Cam - A	<i>An Introduction</i>
5/Cam - F	<i>Features</i>
5/Cam - M	<i>Maintenance</i>
5/Cam - TE	<i>Test Equipment</i>
5/Cam - TR	<i>Troubleshooting and Repair</i>
5/Cam - TR - EA	<i>Electrical Adjustments</i>
5/Cam - TR - EA - BC	<i>Brightness and Contrast</i>
5/Cam - TR - EA - C	<i>Chroma Setup</i>
5/Cam - TR - EA - F	<i>Focus</i>
5/Cam - TR - PS	<i>Power Supplies</i>
5/Cam - TR - VM	<i>Voltage Measurements</i>
5/Cam - TR - VP	<i>Video Processing</i>
5/Cam - TR - VP - R	<i>Recording</i>
5/Cam - TR - VP - SC	<i>Sensor Circuits</i>
5/Cam - TR - VP - SPC	<i>Signal Processing Circuits</i>
5/Cam - TR - VP - TCC	<i>Tape Counter Circuits</i>
5/Cam - VCS	<i>Various Case Studies</i>
5/Cam - VCS - Sha-VL-L285U	<i>Sharp VL-L285U</i>

#### 5/VCR *Video Recorder*

5/VCR - A	<i>An Introduction</i>
5/VCR - A - VHS	<i>VHS Standard</i>
5/VCR - M	<i>Maintenance</i>
5/VCR - TE	<i>Test Equipment</i>
5/VCR - TR	<i>Troubleshooting and Repair</i>
5/VCR - TR - AP	<i>Audio Problems</i>
5/VCR - TR - AP - M	<i>Monitoring</i>

Table of  
Contents

---

---

---

---

<b>5/VCR - TR - AP - R</b>	<i>Recording</i>
<b>5/VCR - TR - CSP</b>	<i>Control and Servo Problems</i>
<b>5/VCR - TR - MA</b>	<i>Mechanical Adjustments</i>
<b>5/VCR - TR - MA - HA</b>	<i>Height Adjustments</i>
<b>5/VCR - TR - MA - TA</b>	<i>Tension Adjustments</i>
<b>5/VCR - TR - MA - TC</b>	<i>Torque Checking</i>
<b>5/VCR - TR - MA - TT</b>	<i>Tape Transport</i>
<b>5/VCR - TR - VP</b>	<i>Video Processing</i>
<b>5/VCR - TR - VP - C</b>	<i>Color</i>
<b>5/VCR - TR - VP - FPC</b>	<i>Frequency and Pulse Control (Automatic)</i>
<b>5/VCR - TR - VP - LC</b>	<i>Luminance Circuit</i>
<b>5/VCR - TR - VP - PI</b>	<i>Phase Inversion</i>
<b>5/VCR - TR - VP - R</b>	<i>Recording</i>
<b>5/VCR - VCS</b>	<i>Various Case Studies</i>
<b>5/VCR - VCS - HiVT34A</b>	<i>Hitachi VT-34A</i>

## 5/Cam - A

### An Introduction

#### VHS, SVHS, SVHS-C, VHS-C, 8mm, Hi-8 and Beta

A camcorder is a video recording device which consists of a video camera and a video recorder all in one package. As with home decks, camcorders are available in a variety of formats—SVHS, VHS, SVHS-C, VHS-C, 8 mm, Hi-8 and Beta. VHS has been dominant and is generally the standard by which others are compared.

#### Beta

As Beta's popularity began to fade, its manufacturers and fans claimed that the images were better. To drive this home, Beta's quality improved even more. VHS answered with Super-VHS (SVHS) which is now recognized as the best in resolution for consumer equipment.

#### SVHS

The SVHS camcorder is a unit capable of recording the separate luminance and chrominance video signals onto videotape. This allows for a better picture and higher resolution. An SVHS camcorder is capable of up to 420 lines of horizontal resolution. That is excellent resolution, especially when you consider that a regular television without SVHS capability will only produce about 330 lines of resolution. Standard VHS camcorders are only rated at about 250 lines of resolution.

SVHS systems will often be Hi-Fi capable, with flying erase heads for better joining of video recordings. Regular VHS tapes will not record in the Super VHS mode in an SVHS machine. Regular VHS tapes will work in an SVHS recorder, but will record as they would in a standard VHS machine.

Most camcorders will only record in the SP (standard play) mode, giving a maximum record time of about 2 hours and 40 minutes (when using a T-180 tape). On those machines with SLP (super long play) or EP (extra play) modes, a maximum of 8 hours can be recorded with the T-180 tape.

#### SVHS-C VHS-C

SVHS-C and VHS-C camcorders are units with smaller version tapes of the SVHS and VHS machines, respectively. They were developed for the camcorder market in an effort to make the camcorders smaller and lighter. With a proper adaptor or video recorder, SVHS/VHS compact video cassettes can be played in standard SVHS/VHS machines.

Since these tapes are smaller, they cannot record as long as standard videotapes. They are limited to about 20 minutes in the SP mode or a maximum of 1 hour in SLP or EP mode.

### 8 Millimeter Hi-8

The other miniature camcorders, 8 millimeter and Hi-8, provide an even more compact, lighter unit. It can fit into the palm of a hand. The resolution of an 8mm camcorder is between 300 and 330 lines. Also, the 8mm units have flying erase heads. As a rule, the 8mm camcorder can record to a maximum of 4 hours. Hi-8 camcorders provide Hi-Fi sound recording and are otherwise similar to the 8mm camcorder.

Beta camcorders produce video images on Beta videotape. Beta camcorders are able to record, but not play. A Beta camcorder has about 280 lines of resolution, which is slightly better than a standard VHS machine. Average record time is five hours.

### Tubes and Chips

Most camcorders available today will use a charge-coupled device (CCD) chip or a MOS chip to capture video images. These chips will typically have up to 360,000 pixels for picking up video images. An average resolution for a chip camera is about 330 lines. Most low-end camcorders will be rated at 270 lines.

CCD chips are lighter, better at viewing strong light or reflections without burning an image in, have much lower power consumption and extremely low light capabilities. Many camcorders on the market boast 3 lux capabilities. A low lux rating enables a camcorder to record better in lower light.

The older method of recording video images is with a tube. Tubes used in camcorders are newvicon, saticon and vidicon. Usually these are found in stand-alone cameras that hook to portable VCRs. Tube cameras tend to be bulky, heavy, with higher power consumption and a short life (typically about 5 years or less). Today, almost all camcorders use the CCD or MOS chip configuration.

### CamcorderBlock Diagram

The basic block diagram of a VHS camcorder is shown in Figure 1. Within a VHS camcorder can be found a video drum assembly with 4 heads. The video tape wraps 270° around this 41.3 mm drum assembly. The head drum rotates at 2700 rpm. (A table top VCR will have a drum assembly that is 62 mm across with a 180° tape wrap. Rate of head rotation is 1800 rpm.) The use of a 4-head configuration and the 270° wrap creates a record pattern that is equivalent to that of a standard 2-head VHS pattern. During record or playback in a camcorder, the tape will be in contact with at least 3 video heads at any one time. Only one head needs be turned on during playback and record, and head selection is controlled by the head switching circuits.

# 5/Cam Camcorder

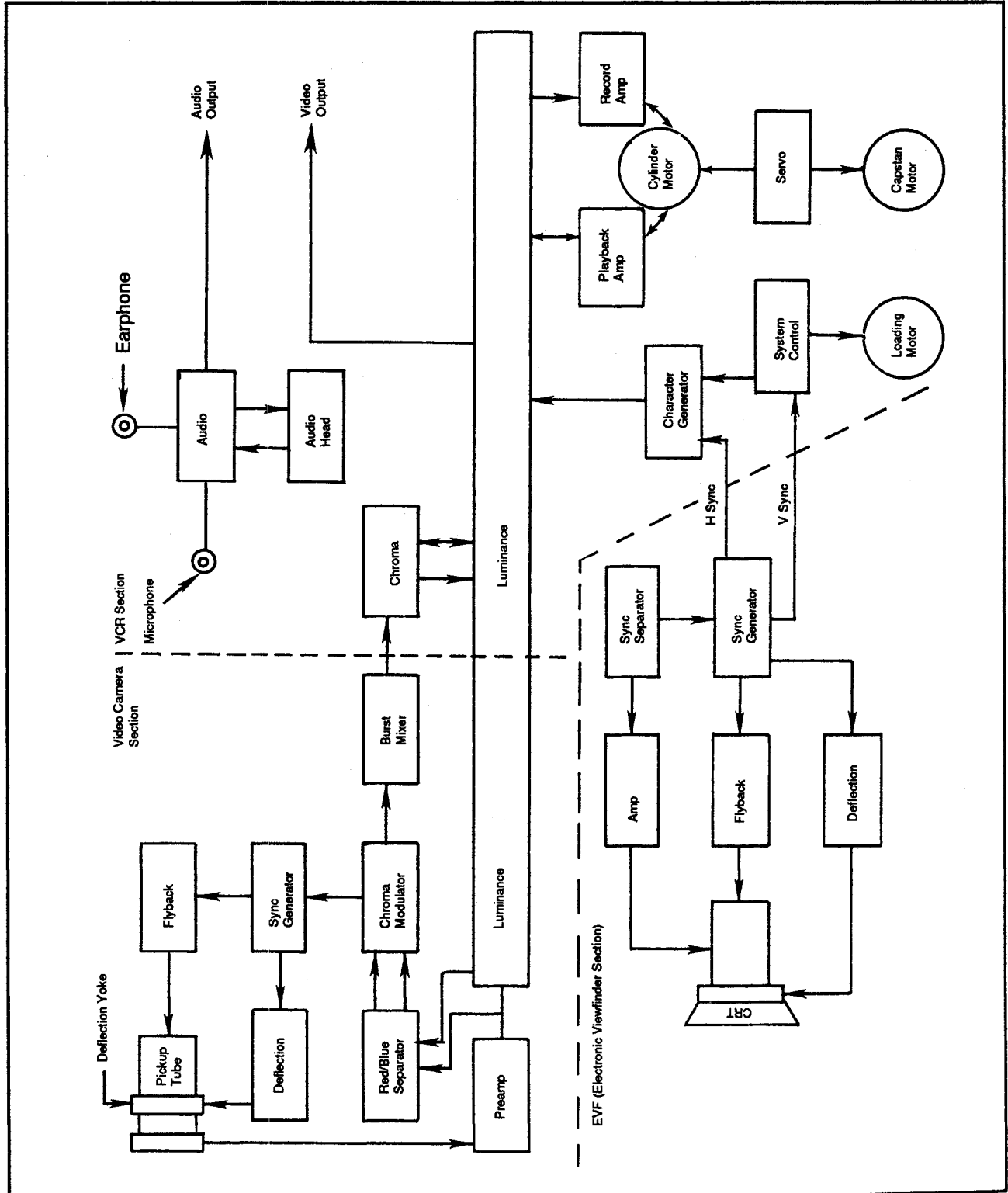


Figure 1: Basic block diagram of a VHS camcorder

**Test Equipment  
and Tools**

When servicing camcorders you will need a dual trace delayed sweep oscilloscope, a vectorscope, a good monitor, test charts and/or pattern generator, a DMM, and a light source of correct color and temperature.

The oscilloscope should not need to be above 30 MHz for checking the operations of a camcorder. Waveform patterns and peak-to-peak voltages for circuits are measured with the oscilloscope.

The vectorscope is used to display generated chroma phase signals and camera output signal amplitudes during adjustments.

A good quality monitor with overscan allows you to have the ability to see everything the camera pick-up sees.

Grayscale charts, white cards, and color-test patterns are needed to correctly adjust the color of a video camera. When using test charts, a light source between 3200 °K and 3400 °K is needed. These light sources must be evenly spread, or diffused across the test chart. In addition to the afore mentioned test charts, focus and back focus charts may be required.

**Troubleshooting**

In the troubleshooting section we discuss the areas related to the camera section. Section "5/VCR - TR" explains VCR repairs and alignments. Refer to Section "5/VCR - M" when doing camcorder VCR maintenance. The sections of the VCR portion that are related to the camera and viewfinder are also discussed in "5/VCR - TR".



# 5/Cam

## Camcorder

5/Cam - F

Features

## 5/Cam - F

### Features

Camcorders are equipped with many features. These features are worth noting as they could be potential areas for problems. (Refer to the camcorder consumer manual for a complete overview of available functions.)

All of the automatic functions sense the dominant subject or condition and make adjustments. Because of this, all of the automatic features can be easily fooled (see below), with the result being that the person using the camcorder might think that the unit is malfunctioning. Often, all you have to do is switch from automatic to manual. This falls into the troubleshooting categories of “look for the obvious” and “check for operator error.”

#### Autofocus

Some camcorders use autofocus all the time, and have no manual override. When this is the case, a precisely adjusted focusing section is important for the unit to operate properly.

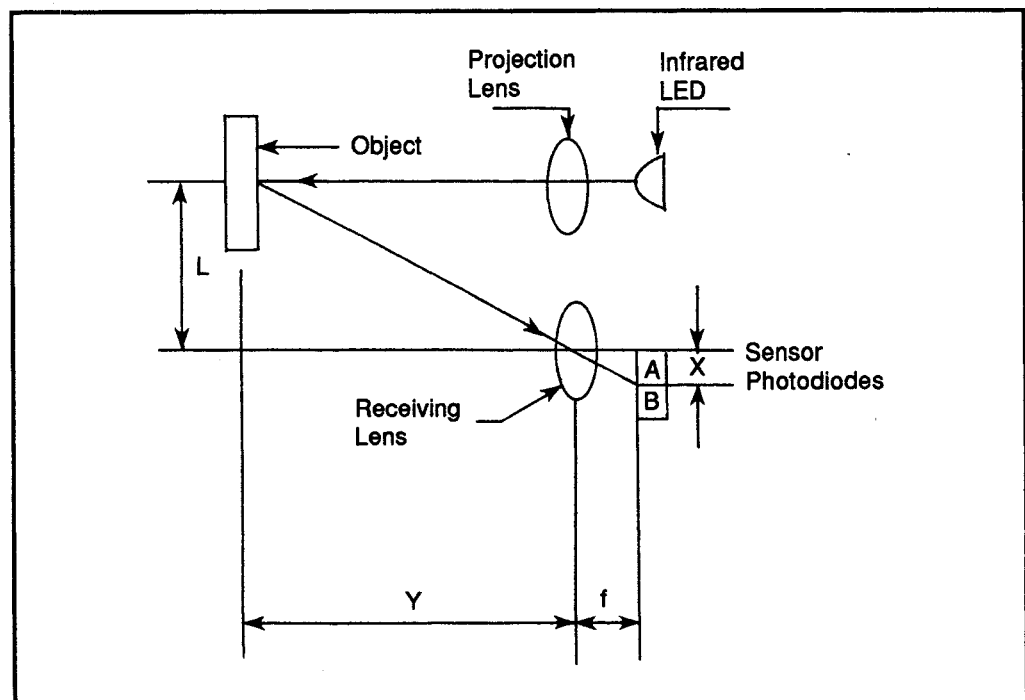


Figure 1: Infrared autofocus

# 5/Cam

## Camcorder

5/Cam - F

Features

Most often, autofocus is accomplished with the use of an infrared beam. This invisible beam is sent from the camcorder to the object and reflected back to the receiving lens.

Before suspecting a problem with the unit, try a test shoot of a stationary object, or switch to manual. Also, try cleaning the autofocusing lens.

Be aware that the infrared beam can react in unpredictable ways. Glass or water, for example, can cause difficulties, especially if either is dirty. Objects that are very dark, and particularly those that are black, might absorb so much of the infrared beam that the autofocus will not work.

### Automatic Iris

The automatic iris controls the amount of light allowed to pass through the lens to the pick-up device. Some camcorders have the ability to use manual iris controls, others do not. The automatic iris mechanism is referred to a meter system that mechanically connects drive and brake coils.

### Auto White Balance

The auto white balance circuit continuously adjusts and changes with fluctuations in illumination during shooting. This circuit controls the gain of the blue and red chrominance signals to maintain proper white balance. White balance is the adjustment of the recording system to the color temperature of the light illuminating the subject.

Some models may have preset switches that set the white balance circuits to average levels. These are typically balanced for outdoor (sunlight) and indoor (tungsten) lighting. There is also a position which puts the camera in the full auto white balancing mode. This allows you to white-balance the camera to a reference source (such as a white card).

### The Lens

The lens of a typical camcorder will be an f1.2 lens with a 6-to-1 zoom ratio. The zoom control of the lens can be electronic or manual. Most camcorder lenses also include a macro function that allows you to focus on images as close as 1/2 inch.

### Electronic Viewfinder

The electronic viewfinder (EVF) is a mini black-and-white picture screen that allows videographers to see what they are shooting as it happens. The EVF can also review previously recorded material. Some EVFs can be purchased for full-color viewing. These are more costly and consume more power.

The EVF is like a mini-monitor and should be repaired in a similar fashion to a TV monitor.

# 5/Cam Camcorder

5/Cam - F

Features

## Microphone and Earphone

Camcorders will have a built-in microphone that may be able to be removed, or muted. Most camcorders allow for the use of an external microphone. These microphones may be mono or stereo, depending on the type of camcorder.

Consumer-grade camcorders will rarely have a means of adjusting the audio level. A circuit inside automatically adjusts this level. An earphone, or headphone plug may be available for hearing what you are recording. A few camcorders have a built-in speaker in the left side of the camcorder (to be near the operator's right ear). The purpose is to allow the operator to monitor the audio while recording. If present, the speaker will have a volume control.

## HQ Circuitry

Many camcorders have built-in high-quality (HQ) circuits. HQ technology improves the quality of VHS recordings, while keeping compatibility with conventional VHS machines. It does this by raising the white clip level and adding a detail enhancer.

## TV Hookup

Most camcorders have some provision for hooking directly to a television receiver. This may be from an external RF converter or an internal converter. It may also be possible to hook up the separate audio and video lines from a camcorder to a VCR or TV receiver. RF connections will typically be 75 ohm and output on channel 3 or 4.

## Power Supplies

The power for a camcorder is most often supplied by a battery pack. It may also be powered by an AC adaptor, which usually doubles as a battery charger. Batteries can allow up to 2 hours of continuous use before needing recharging. Before recharging, it is preferable that the batteries be completely discharged. Charging a battery after, for example, 15 minutes may cause the battery to develop a "memory". If the battery is not fully discharged it might "think" that the partial discharge is a complete discharge. If this happens, the battery will not perform at a maximum level, because the battery will "think", it is discharged when it is not.

The AC adaptor is electronically switchable to allow the use of power from anywhere in the world, using 110 or 240 V at 50 or 60 Hz.

The AC adaptor of many camcorders (Panasonic, GE, Philco, etc.) is the means through which the camcorder is connected to a television. The AC adaptor camcorder cable plugs into the camcorder. Then, the hookup to the monitor/TV is made either through separate video and audio connections or an RF cable.

**5/Cam**  
Camcorder

---

5/Cam - F

---

Features

---

---

## 5/Cam - M

### Maintenance

---

Whether or not you follow manufacturer suggested maintenance schedules for camcorders depends on who you talk to. One manufacturer will insist that certain parts must be adjusted or replaced on a certain schedule to maintain proper camcorder operation. Others agree that maintenance should be on a “fix it if it’s broke” basis. The latter method is basically sound, with the exception of periodic cleaning. In either case, follow the manufacturer’s recommendations as you feel fit.

The periodic cleaning includes keeping the unit clean (exterior) and periodic cleaning of the video heads (interior).

Video head cleaning is discussed in section “5/VCR-M Maintenance”. The only difference for camcorders is that access to the heads and tape path is tighter, and removing the cover is not easy (and may be nearly impossible without causing damage). You may find it necessary to use swabs with longer handles. If so, avoid the temptation to apply additional pressure. The rule is still the same: let the cleaning fluid do the work, not the pressure.

To reduce the amount of cleaning needed, the camcorder should always be kept in a case, or at least covered, when not in use. This reduces the amount of exposure to the environment.

Exterior cleaning includes the cleaning of the lens, battery contacts and the housing of the unit. A damp cloth is best for cleaning the housing case. The lens should be cleaned only with a proper lens cleaner and lens tissue. Anything else will scratch the lens.

Battery contacts may become corroded or soiled with deposits and need to be periodically cleaned to maintain proper power contact connections. Clean with a denatured alcohol cleaner. For tougher deposits a pencil eraser can be used to clean the contacts.

**5/Cam**  
Camcorder

---

5/Cam - M

---

Maintenance

---

# 5/Cam Camcorder

5/Cam - TE

Test Equipment

## 5/Cam - TE Test Equipment

### Alignment Tools

To set-up and align the camera section of a camcorder, you need (in addition to standard test equipment):

- Monitor/TV
- Tripod
- Light source and meter
- Lightbox or pattern box
- Adjustment charts

The camcorder may have a lens reference mark used to position the camcorder a precise distance from the object being videographed. The lens reference mark (if one is used) will be located on the top of the lens. The service manual will indicate the proper distance for alignment.

#### Monitor/TV

A monitor/TV used for camera alignment must have some provision for overscan (the ability to see more picture than a normal TV). The monitor/TV should have the ability for separate video and audio inputs. This produces cleaner signals than going through an RF connection.

If you use a standard TV for viewing camcorder output during alignment, the vertical height can be adjusted to underscan the picture (this allows the viewing of the video switching point in relation to the start of the vertical blanking).

#### Tripod

The tripod may seem trivial, but without a tripod you will have great difficulty holding the camcorder steady enough to make adjustments. Any decent tripod will work for camcorder adjustments.

#### Light Source and Meter

In order to make camcorder adjustments, light levels must be at an acceptable color temperature (usually 3200°K). A 3200°K quartz lamp works best for this.

The correct color temperature is essential for proper adjustments.

A light meter that reads in lux is suggested to set proper light on a test chart. Most

# 5/Cam

## Camcorder

5/Cam - TE

Test Equipment

service literature specifies light in lux levels rather than footcandles. (A footcandle is equal to 10 lux.)

### Light Box or Pattern Box

The light box is an excellent light source and chart holder that produces a light of 3000°K at 100 lux within the box. The box is transparent and has clips or slots to hold the various adjustment charts.

The alternative method is to clip the charts to some kind of stand and flood the surface of the chart with the appropriate light source, at the proper distance.

### Test/Alignment Charts

Kits with test/alignment charts can include a gray scale chart, color chart, Siemens star chart, resolution chart, autofocus chart and a backfocus chart. The charts are referenced and used during different alignment procedures. For instance, the backfocus chart is used to determine if the focus remains constant through the entire zoom range.

### Alignment Setup

For tube cameras, the camera should be allowed to warm up for at least 30 minutes. Chip cameras don't usually need warm-up periods (although it wouldn't hurt for circuits that change due to temperature).

Make sure you are receiving a picture of the test chart on the monitor. The test chart should be illuminated at a level indicated by the service manual. The auto white balance circuit should not be active (unless the camcorder gives you no option). The camcorder should be set to the 3200°K position, when available.

There may be a provision for disabling the white balance circuit described in the service manual. This is usually a resistor connected across a pin for the auto white balance circuit of the camcorder.

### Standard Test Equipment

For standard test equipment needed see article "5/Cam - A."



# 5/Cam Camcorder

5/Cam - TR	Troubleshooting and Repair
5/Cam - TR - EA	Electrical Adjustments
5/Cam - TR - EA - BC	Brightness and Contrast

## 5/Cam - TR - EA Electrical Adjustments

### 5/Cam - TR - EA - BC Brightness and Contrast

#### Automatic Iris Level Adjustment

The automatic iris waveforms (AIC) are shown in Figure 1. If the level of this adjustment is set too high or too low, the picture will appear dark or bright under normal lighting.

The camera should be set to view the gray scale chart. The grayscale should fill the screen. The oscilloscope is connected to the video output. Use the horizontal rate to trigger the scope. The AIC controls should be adjusted for  $700 \pm 10$  mV peak-to-peak. Turn the chroma gain to the center after the AIC adjustment.

#### AGC

With the camera viewing the gray scale chart, the automatic gain control (AGC) can be set. The AGC test point is connected to the scope through a resistor ( $18 \text{ k}\Omega$ ). The horizontal rate is used to trigger. Adjust the low-light gain

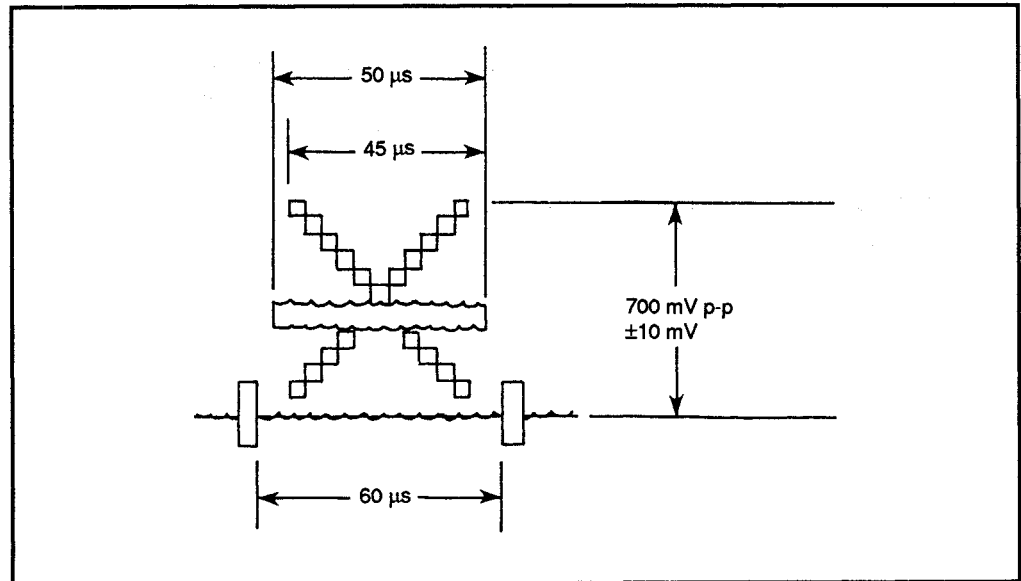
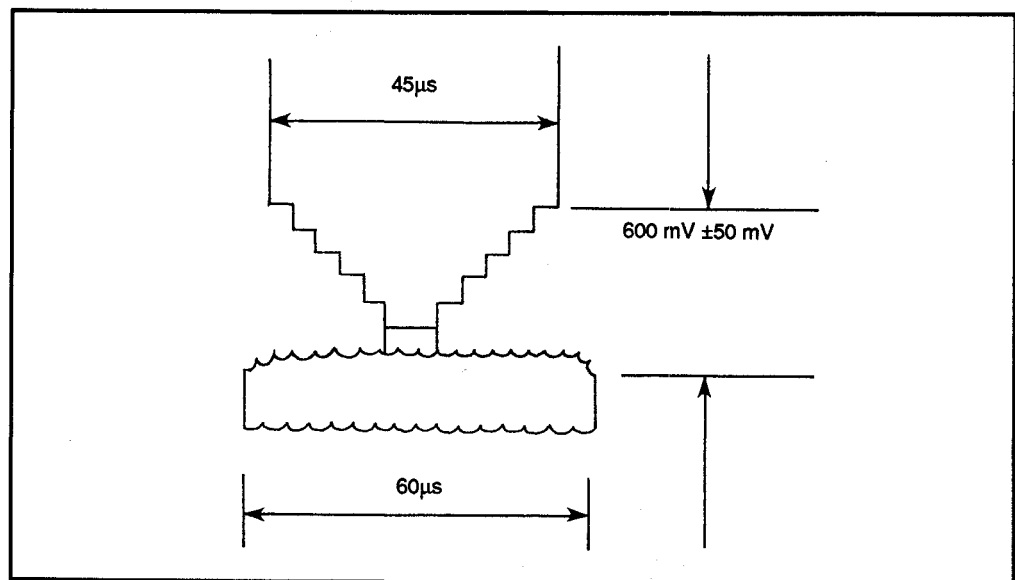


Figure 1: AIC level waveforms

control so the waveform is  $600 \pm 50$  mV peak-to-peak. This waveform is shown in Figure 2.

### Dark Shading

Cap the camera for this adjustment. Figure 3 shows the waveforms associated with this adjustment. The oscilloscope is connected to the dark shading test point through a resistor ( $18 \text{ k}\Omega$ ). The scope is triggered with the vertical rate. Adjust the dark shading vertical saw control and the dark shading vertical parabolic control so the waveform is flat. Trigger the scope with the horizontal rate. Adjust



**Figure 2:** AGC maximum gain waveform

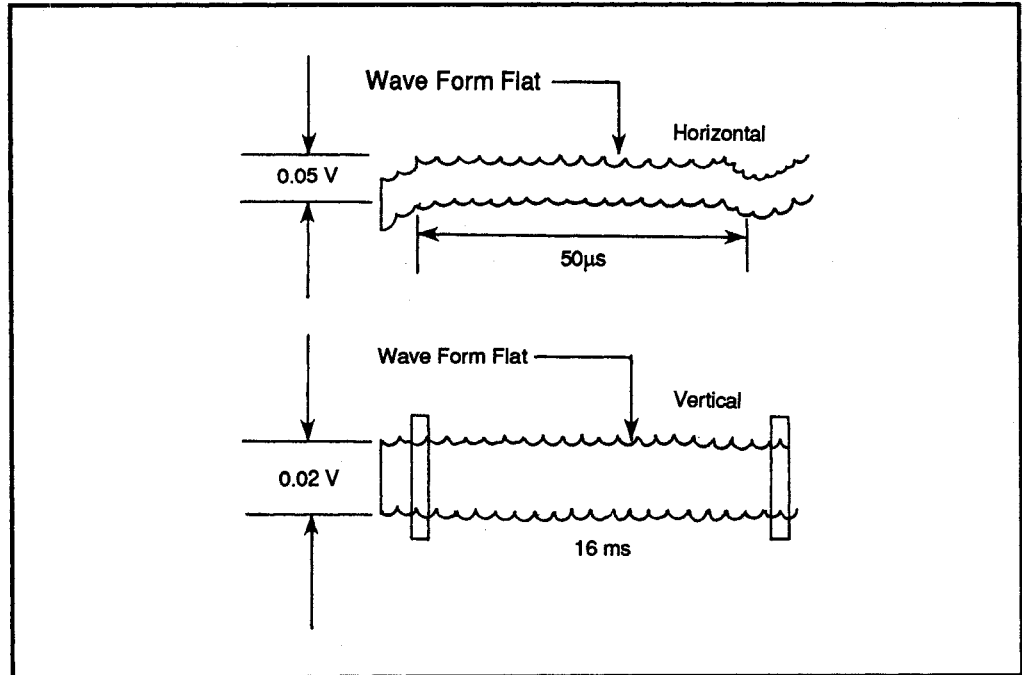
the dark shading horizontal saw control and the dark shading horizontal parabolic control so the waveform is flat.

### Black Level

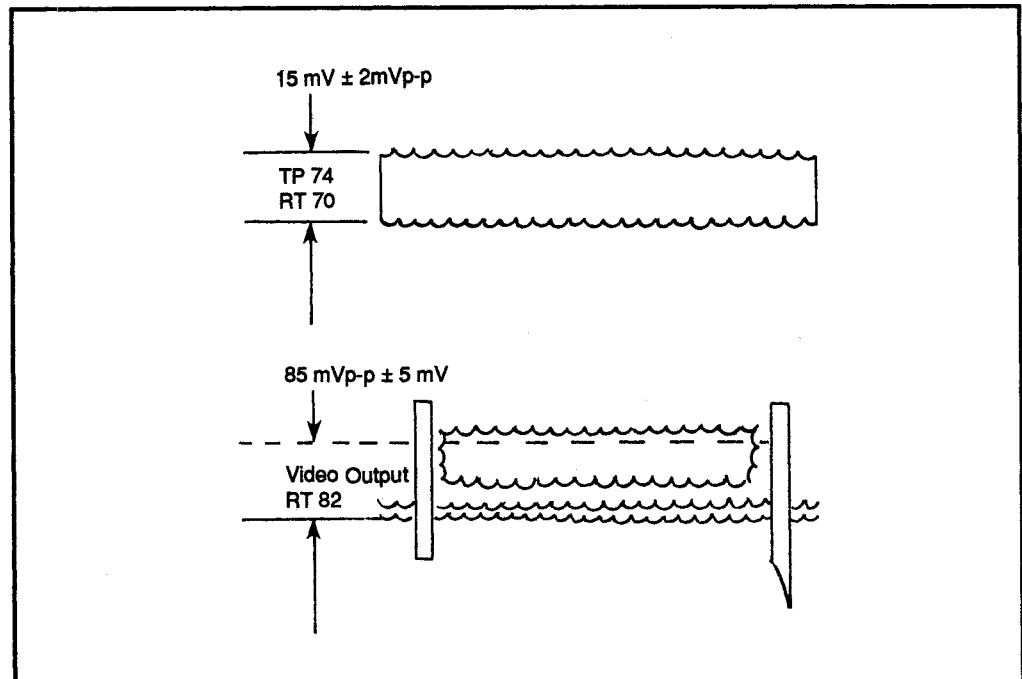
Figure 4 shows the waveforms for the black level adjustment. Cap the lens or close the iris. Connect the oscilloscope to the black level test point. Trigger the scope with the horizontal rate. Adjust the AGC offset control for  $15 \pm 2$  mV peak-to-peak from the blanking level to the center of the waveform. Connect the scope to the video output and adjust the Y setup control for  $85 \pm 5$  mV peak-to-peak from the blanking level to the center of the waveform.

### Chroma Carrier Level

The waveform for the chroma carrier level adjustment is shown in Figure 5. The purpose of the adjustment is to set up the carrier level of the chroma signal. This helps ensure proper tint levels.



**Figure 3:** Dark shading waveforms



**Figure 4:** Black level waveforms

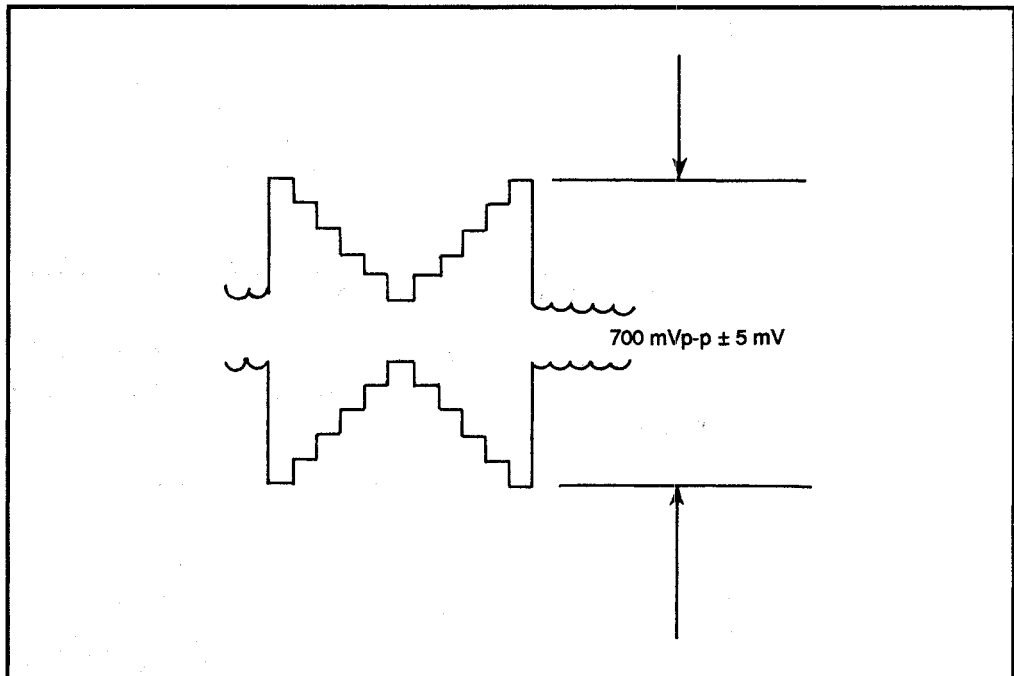
# 5/Cam Camcorder

5/Cam - TR	Troubleshooting and Repair
5/Cam - TR - EA	Electrical Adjustments
5/Cam - TR - EA - BC	Brightness and Contrast

For this test, use the gray scale chart. The oscilloscope should be connected to the chroma carrier test point and triggered by the horizontal rate. Adjust the focus control to maximize the waveforms. Then, adjust the carrier gain control so the waveform is  $700 \text{ mV} \pm 50 \text{ mV}$  peak to peak.

## Chroma Set-Up

Dark areas in a video image may have color noise. This adjustment reduces the amount of possible color noise. This adjustment should be done with the lens capped or the iris closed. Figure 6 shows the related waveforms for this adjustment.



**Figure 5:** Chroma carrier level waveform

The oscilloscope will be connected to two test points—the blue chroma (channel 1) and the red chroma (channel 2) test points. Trigger the scope with the horizontal rate.

Adjust the blue setup control so the chroma level at channel 2 matches the blanking level. Adjust the red setup control so the chroma level at channel 1 matches the blanking level.

## Tracking Preset

The waveforms associated with the tracking preset are shown in Figure 7.

**5/Cam**  
Camcorder

5/Cam - TR

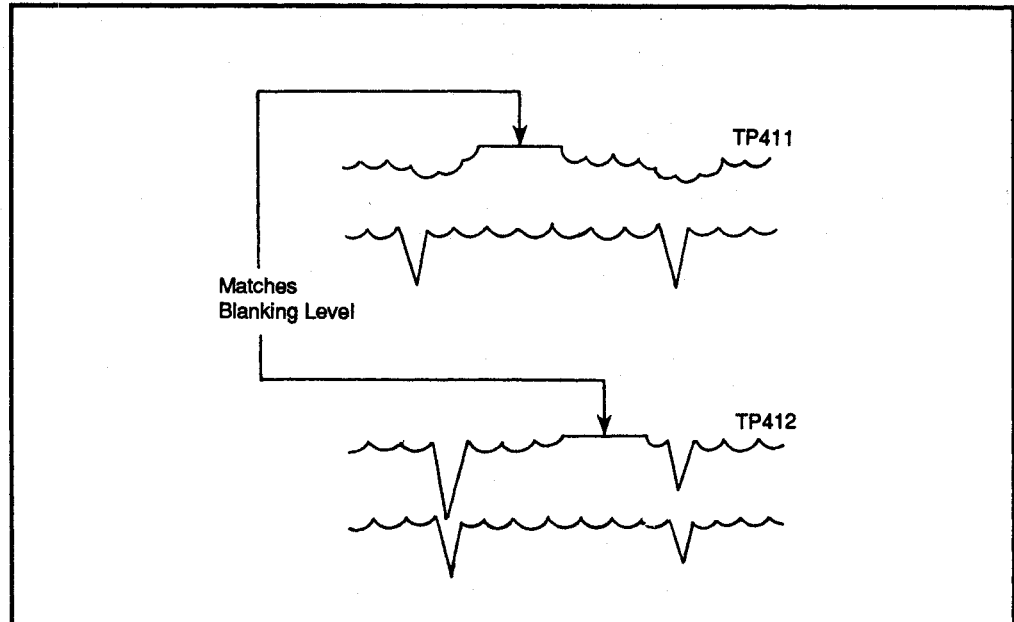
Troubleshooting and Repair

5/Cam - TR - EA

Electrical Adjustments

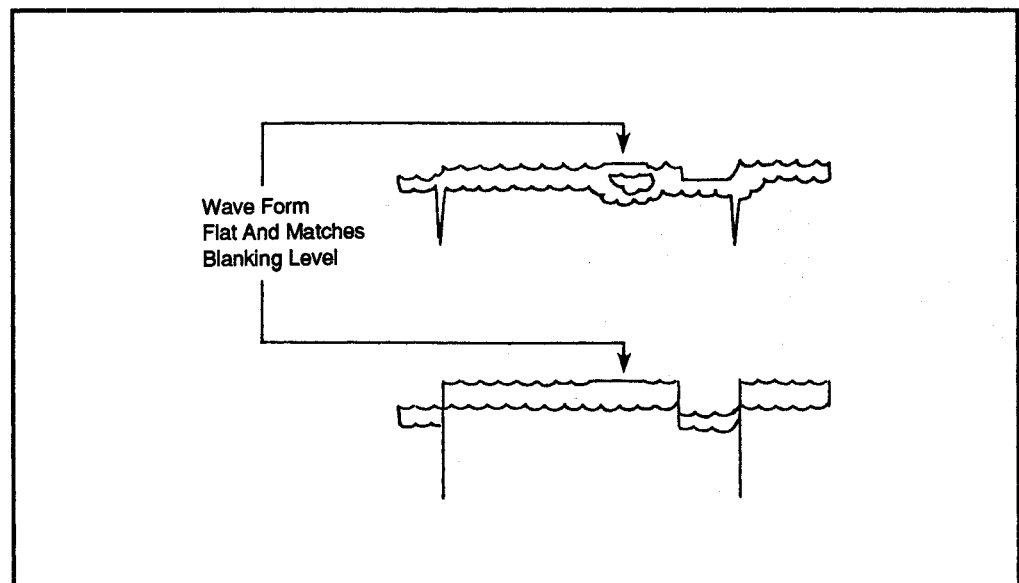
5/Cam - TR - EA - BC

Brightness and Contrast



**Figure 6:** Chroma set-up waveforms

Use the gray scale chart and the oscilloscope. Fill the monitor screen with white. Connect the oscilloscope channel 1 to the blue test point and channel 2 to the red test point.



**Figure 7:** Tracking preset waveforms

**5/Cam**  
Camcorder

5/Cam - TR	Troubleshooting and Repair
5/Cam - TR - EA	Electrical Adjustments
5/Cam - TR - EA - BC	Brightness and Contrast

Trigger the scope with the horizontal rate. Adjust the blue tracking 2 control and the blue tracking 3 control to make the waveform flat and match the blanking level of the blue signal.

Do the same for the red tracking preset at the red tracking test point and controls.

**Confirming White Balance**

Check to see if the white balance is working properly in both the manual and auto modes. If there is a big difference between the two modes, the chroma setup may need to be readjusted. R and B signal separation, R and B gain and tracking adjustments may also need to be made.

# 5/Cam Camcorder

5/Cam - TR

Troubleshooting and Repair

5/Cam - TR - EA

Electrical Adjustments

5/Cam - TR - EA - C

Chroma Setup

## 5/Cam - TR - EA Electrical Adjustments

### 5/Cam - TR - EA - C Chroma Setup

#### R and B Signal Shading Release

Both channels of the oscilloscope are required to make these adjustments. The R and B signal shading waveforms are shown in Figure 1.

Channel 1 of the scope is hooked to the R signal shading release test point. Channel 2 is hooked to the B signal shading release test point. The scope will be triggered with the horizontal rate.

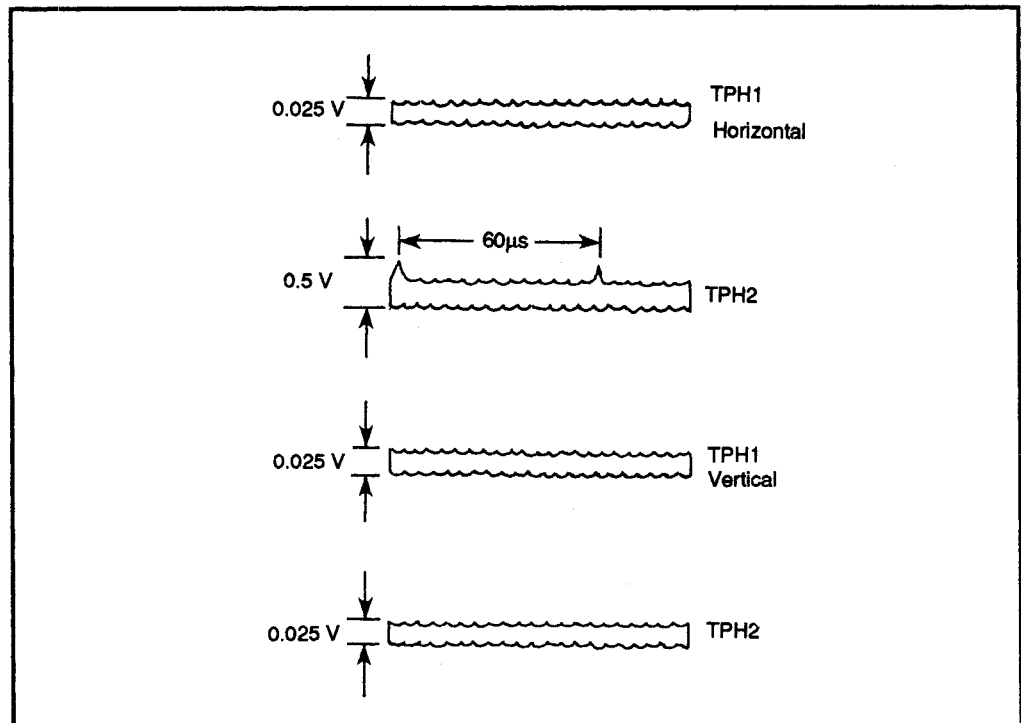


Figure 1: R and B signal shading release waveforms

Adjust the red shading horizontal control and the red shading horizontal parabolic control to make the waveform for channel 1 flat. Adjust the blue

# 5/Cam Camcorder

5/Cam - TR

Troubleshooting and Repair

5/Cam - TR - EA

Electrical Adjustments

5/Cam - TR - EA - C

Chroma Setup

shading horizontal control and the blue shading horizontal parabolic control to make the waveform for channel 2 flat.

Trigger the scope with the vertical rate. Adjust the red shading vertical control and the red shading vertical parabolic control to make the waveform for channel 1 flat. Adjust the blue shading vertical control and the blue shading vertical parabolic control to make the waveform for channel 2 flat.

## R and B Signal Separation Preset

The waveforms associated with the red and blue signal separation presets are shown in Figure 2.

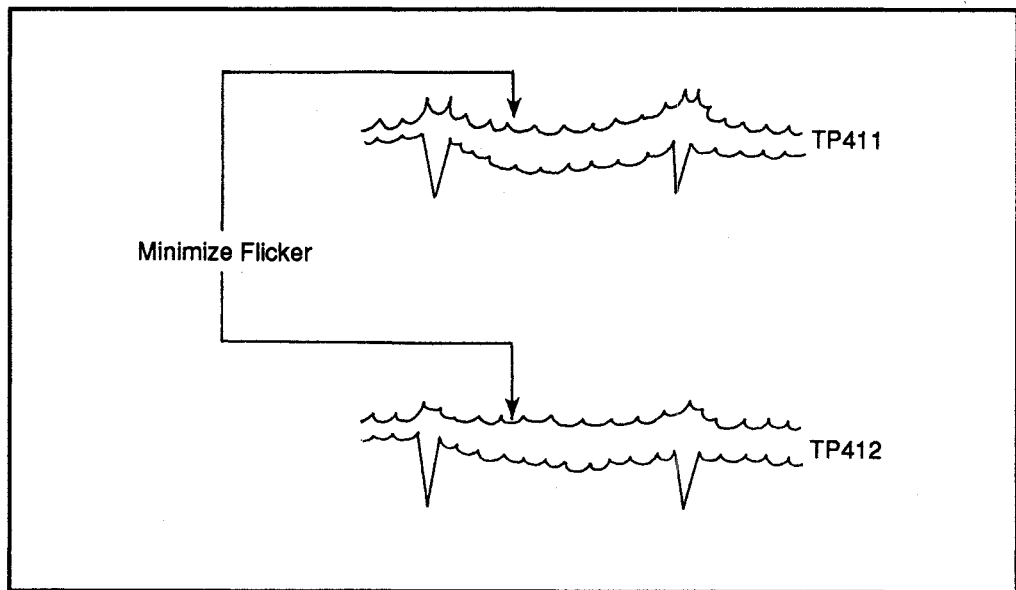


Figure 2: R and B signal separation preset waveforms

Aim the camera at a white source (the lightbox or a white chart). Connect channel 1 to the blue test point and channel 2 to the red test point. Adjust the separation phase control and separation gain control for minimum flicker in the waveforms.

## R and B Signal Gain Preset

The waveforms associated with the red and blue signal gain presets are shown in Figure 3. Aim the camera at a white source. Connect channel 1 to the blue test point and channel 2 to the red test point. Adjust the blue gain control so the top of the chroma level at channel 1 matches the blanking level.

## R and B Shading Preset

The waveforms associated with the red shading preset are shown in Figure 4. Use the white chart or lightbox and the oscilloscope. Fill the monitor screen with white. Connect the oscilloscope to the red test point.



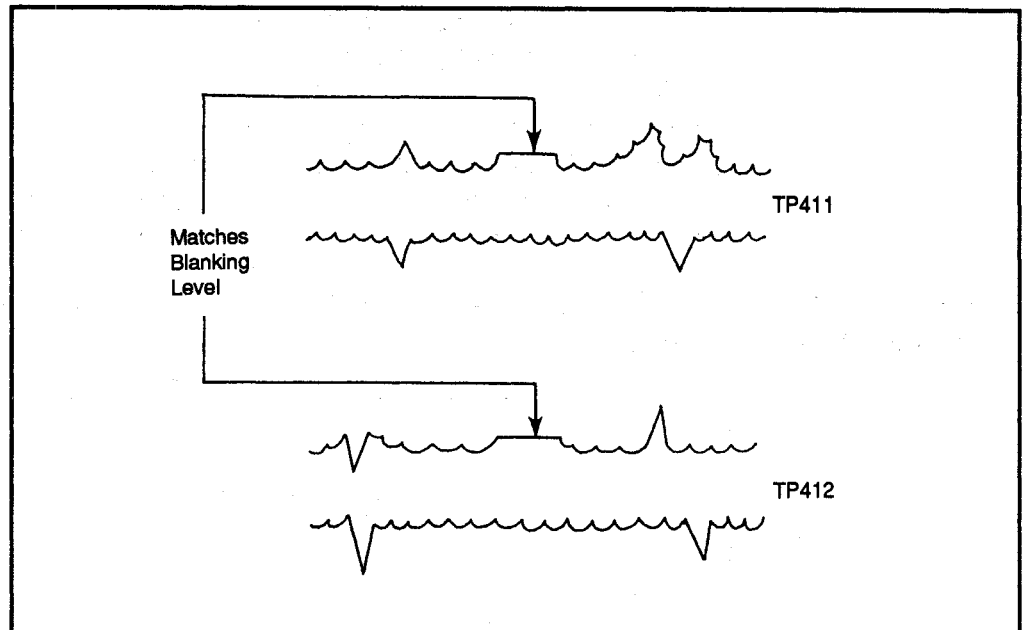


Figure 3: R and B signal gain preset waveforms

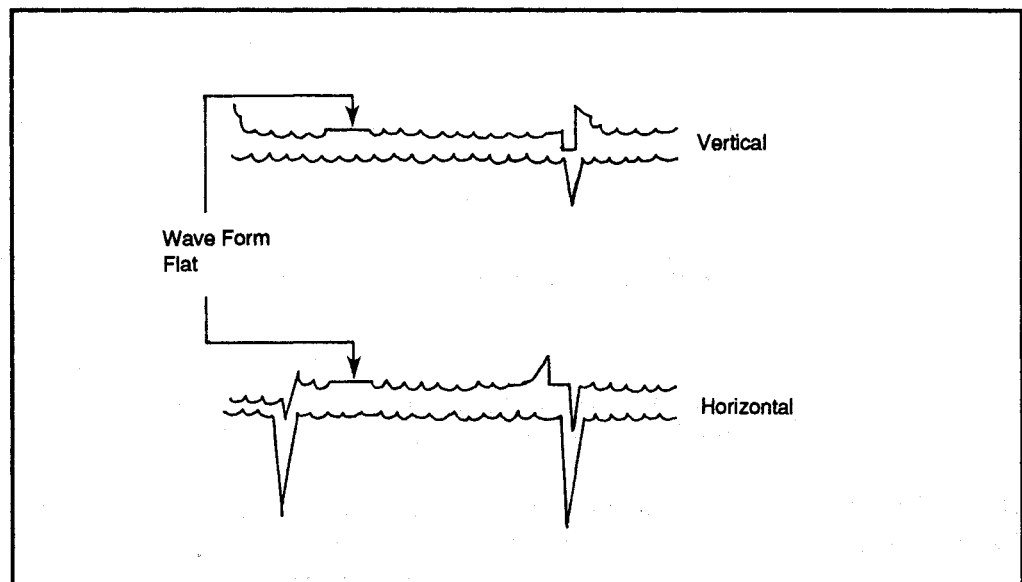


Figure 4: Red shading preset waveforms

Trigger the scope with the horizontal rate. Adjust the red shading horizontal saw control and the red shading horizontal parabolic control to make the waveform flat. Do the same for the blue shading preset at the blue test point and controls.



5/Cam - TR	Troubleshooting and Repair
5/Cam - TR - EA	Electrical Adjustments
5/Cam - TR - EA - C	Chroma Setup

**Burst Frequency Adjustment**

The burst frequency adjustment sets the burst or subcarrier oscillator at the correct frequency. If the subcarrier is set improperly, color, sync, and tint problems can arise.

To set the burst frequency, connect a frequency counter to the subcarrier test point. Adjust the burst or subcarrier oscillator to a reading of 3.579545 MHz (3.58 color burst) with a  $\pm$  of 20 Hz on the frequency counter.

# 5/Cam Camcorder

5/Cam - TR	Troubleshooting and Repair
5/Cam - TR - EA	Electrical Adjustments
5/Cam - TR - EA - F	Focus

## 5/Cam - TR - EA Electrical Adjustments

### 5/Cam - TR - EA - F Focus

#### Backfocus Adjustment

The backfocus adjustment ensures a proper focus through the zoom range. If the backfocus is set wrong, a subject in focus when zoomed-in (telephoto) will not be in focus when zoomed-out (wide angle).

Use the backfocus chart. The chart illumination for the chart should be between 50 and 100 lux. The camera should be positioned 10 ft. (3 m) from the test chart and level with it. Set the lens to the 10 ft. (3 m) position.

Locate the backfocus screw. You may have to remove more than just the casing to locate this screw. It should be located on one side of the back of the lens. The screw could be a hexagonal, Phillips or flat-head screw. Loosen it.

Zoom-in (telephoto) and adjust the lens focus for the best focus on the monitor. Zoom-out (wide angle) and see if the focus changes. If it does, insert the backfocus adjustment driver into the adjustment point. Adjust the backfocus for the best possible focus on the monitor.

Zoom-in again and adjust the lens for the best focus. Zoom-out and adjust the backfocus again. Continue to do these steps until the focus seems to remain steady through the entire zoom range. Remember to tighten the backfocus screw when finished to lock the backfocus.

#### Dynamic Focus Release

The oscilloscope will be needed to make this adjustment. The camera lens cap should be on.

The oscilloscope is hooked to the horizontal rate for the trigger and the dynamic focus test point. The horizontal dynamic focus is adjusted to make the waveform as flat as possible.

Next, trigger the scope with the vertical rate. Adjust the vertical dynamic focus controls, saw control and parabolic control to make the waveform flat.

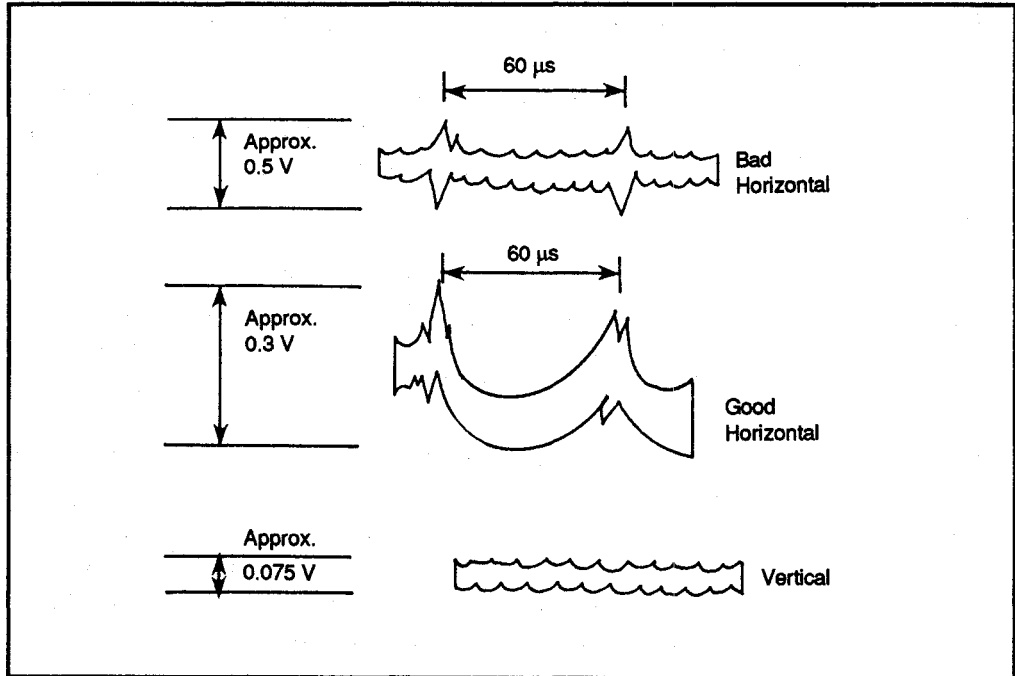


Figure 1: Dynamic focus release waveforms

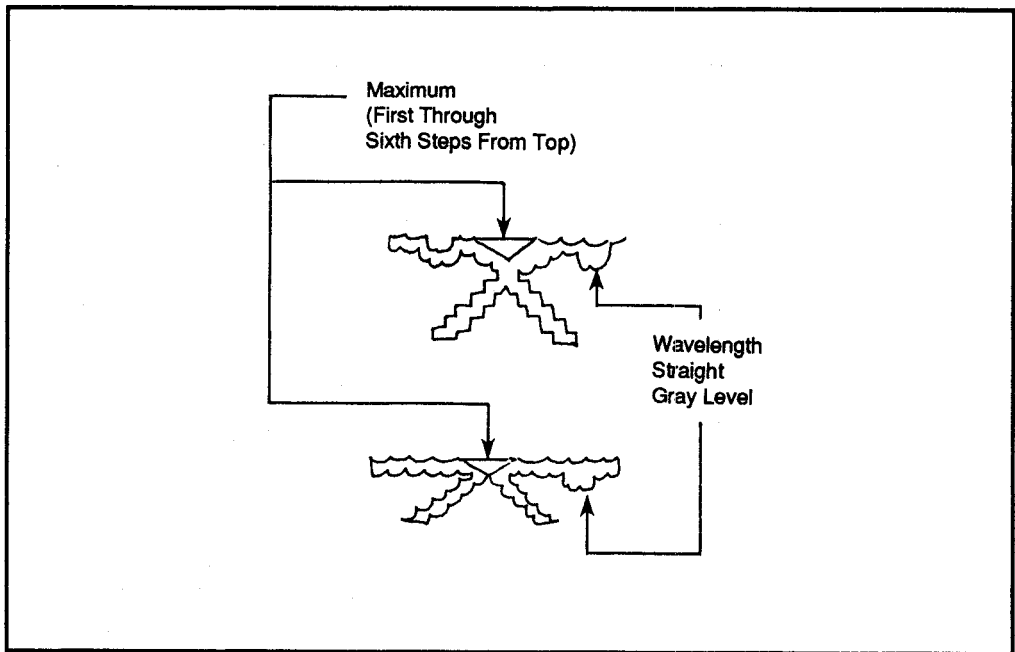


Figure 2: Focus preset waveforms

# 5/Cam Camcorder

5/Cam - TR

Troubleshooting and Repair

5/Cam - TR - EA

Electrical Adjustments

5/Cam - TR - EA - F

Focus

## Focus Preset Adjustment

The waveforms associated with the focus preset adjustments are shown in Figure 2.

Use the gray scale and the oscilloscope. Connect to the composite luminance test point a 47  $\mu$ F/16 V electrolytic capacitor to ground. Connect channel 1 to the blue test point and channel 2 to the red test point. Trigger the scope with the horizontal rate.

Adjust the focus control so the gray level of the waveform is straight, and the first through sixth step from the top are at maximum. The waveform may fluctuate and the separator phase and separator gain controls will need to be adjusted. Then adjust the focus control as previously mentioned.

## Dynamic Focus Preset

The waveforms associated with the dynamic focus preset are shown in Figure 3.

Use the white chart or lightbox and the oscilloscope. Fill the monitor screen with white. Connect channel 1 to the blue test point and channel 2 to the red test point. Trigger the scope with the horizontal rate.

Adjust the dynamic focus horizontal parabolic control and the dynamic focus horizontal saw control to make the waveforms flat.

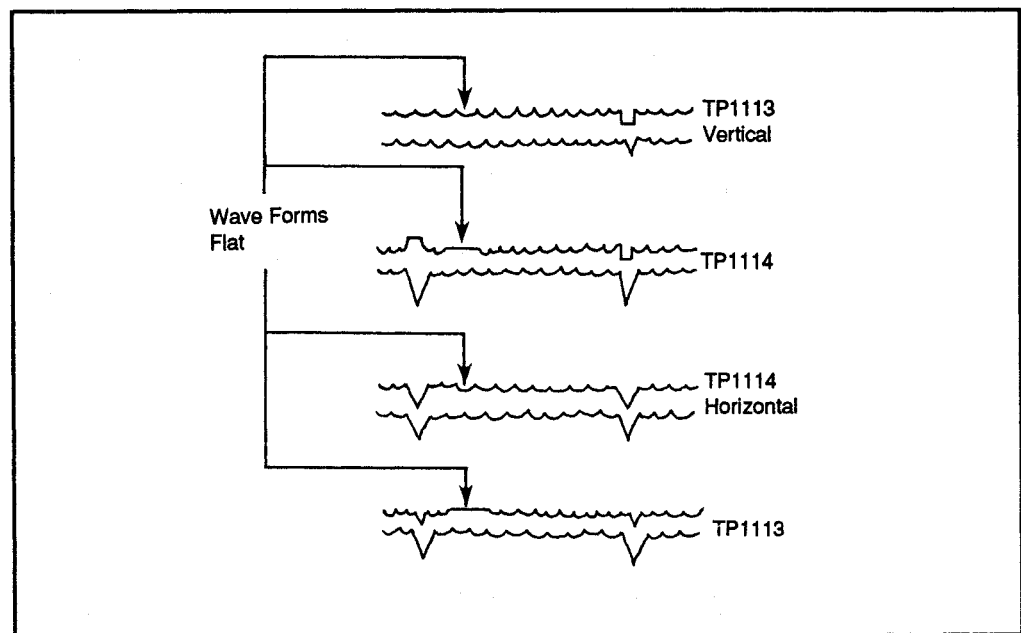


Figure 3: Dynamic focus preset waveforms



5/Cam - TR	Troubleshooting and Repair
5/Cam - TR - EA	Electrical Adjustments
5/Cam - TR - EA - F	Focus

Trigger the scope with the vertical rate. Adjust the dynamic focus vertical parabolic control and the dynamic focus vertical saw control to make the waveforms flat.

You may have to repeat the adjustments several times to achieve the best results. The two adjustments tend to interfere with each other to a degree.

## 5/Cam - TR

### Troubleshooting and Repair

### 5/Cam - TR - PS

#### Power Supplies

The most common problem is a dead camcorder. This is usually caused by a blown fuse, poor battery power, or poor AC power. If the camcorder does not work properly when a battery is inserted, the problem is usually the battery and not the camcorder. Replace the battery with a fresh one, or try the AC adaptor to make sure the camcorder is not at fault. (Note that low battery power can also cause the camcorder to behave erratically.)

Check the battery terminals and the connectors on the camcorder. Improper connections, or intermittent connections can lead you to believe the battery is at fault. Even if you don't suspect the connectors, clean them.

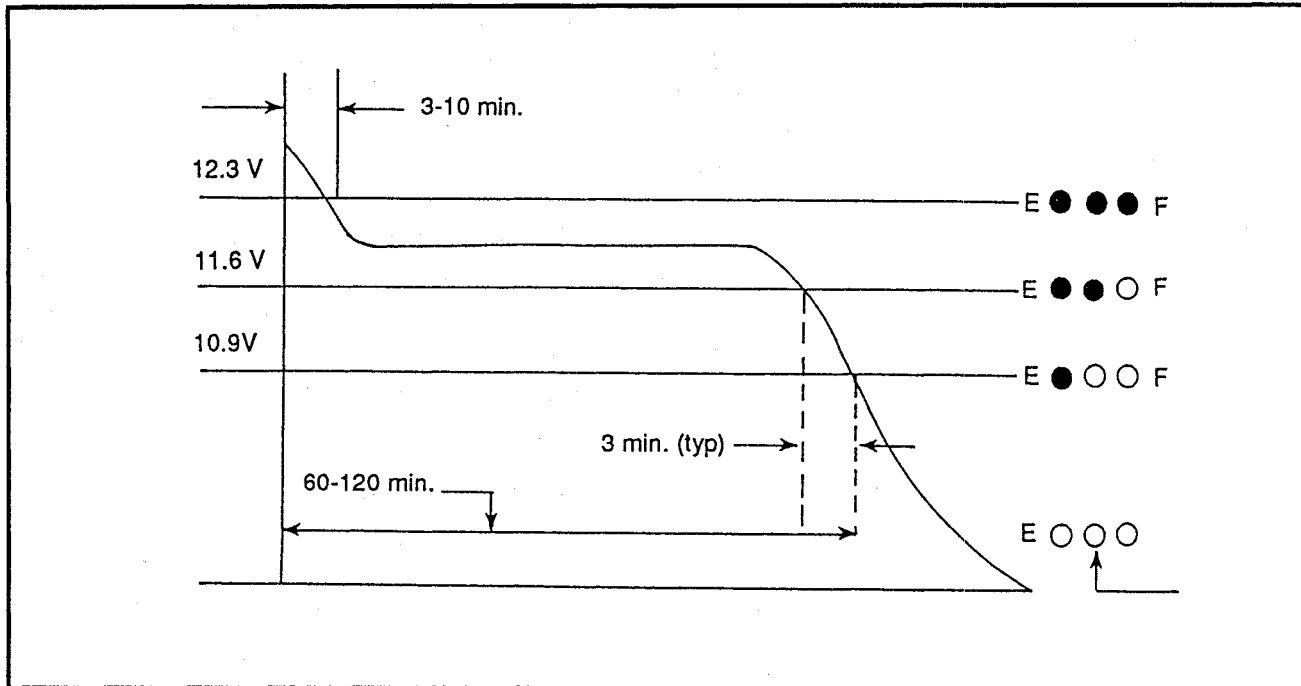
Be aware that the battery pack or AC adaptor must be for that particular camcorder. There are no specific standards. If the battery or adaptor isn't the right one, the camcorder won't work.

If the fuse blows or the camcorder works intermittently, check to see if the fuse is seated well. It may have poor contact, or loose contact causing intermittent operation. Make sure the fuse is a proper fuse replacement. A fuse with a value too low may be blown each time the unit is turned on. One with too high a rating won't protect the unit. A fuse may be found in the camcorder on the power board, as well as in the AC adaptor.

#### AC Adaptor/ Charger

A typical AC adaptor/charger circuits are shown in Figure 3. The circuit will automatically compensate for voltage variations in line voltage and frequency to maintain the rated output voltage. It does not require changing switches to operate properly. The voltages can range from 100 to 240 V and 50 to 60 Hz. Output from the power supply may be 6 V, 7.2 V, 9 V, and 12 V. When charging, the output will be at a voltage level with 1.2 A.

To begin testing an AC adaptor, plug in the unit and test the output for proper voltage. A single voltage output will typically be 12 V. To test the charging



**Figure 1:** Graph of the average life of a typical camcorder battery

connections, attach a 20  $\Omega$ , 10 W resistor across the charging terminals and measure the output voltage. This will determine if the output from the AC adaptor/charger is dead.

If the unit supplies voltage but will not charge a battery, the voltage/charge switch may be dirty. If it is completely dead, open the case and check the fuse. Replace the fuse with the same type and rating. If there is more than one fuse, check each of them. (Some adaptor/charger units are sealed. Disassembly may not be possible without damaging the case.)

Next, check to see if there is voltage across the bridge rectifier unit. Measure voltage across the large filter capacitor. Make sure there are no sensor switches that must be activated for the adaptor to work, or when a battery is inserted into the charger. If there are sensor switches that must be activated, short, or close the switches.

If there is a blown fuse when you open the adaptor, replace the fuse and try the unit again. It is possible that a power spike blew the fuse. The fuse will typically be rated at 2 to 3 A. If the adaptor continues to blow fuses, there could be a short in the bridge rectifier. Diodes in the bridge rectifier can sometimes become



shorted. Check across each diode for leakage. If any are defective, replace the entire bridge. Refer to the service manual for specific information on power at various test points in the charger and check these locations. Make random diode and transistor checks to ensure there are no leaky or shorted components.

It is possible there is an overload somewhere in the adaptor, or that an oscillator circuit is not operating properly. There may be anywhere from two to four ICs within the adaptor. One is used for the primary control oscillator and the others are used for the voltage control and charging circuits. Voltage checks on ICs may show a leaking IC that needs to be replaced. Remove the  $V_{CC}$  supply pin from the circuit board and measure to ground for a low resistance. This resistance will most likely be under 1 K $\Omega$ .

Random check the transistors and diodes to see if any are leaky or shorted. There should be a low resistance in one direction on good diodes and transistors. You should find that most transistors in an AC adaptor will be NPN types. The use of a transistor checker can be very helpful in locating a bad transistor, or the DMM with diode checking and/or transistor checking.

## Batteries and Chargers

Batteries that do not charge may indicate a defective battery and not a defective charger. If other batteries charge, the charger is not at fault. A battery may be unable to recharge because of defects or memory problems. Try discharging the battery completely and recharging it. If after a few hours the battery does not take a charge, it is probably dead.

Check to see if the battery charger is good (as above). Very low voltage output could indicate a defective charging circuit or a faulty charge/voltage switch. The adaptor may work fine when used as the power source for the camcorder, but still not charge the batteries. Check to see if the charge/voltage switch is working properly. Try shunting the switch and retesting the charger section. Systematically check the diodes and ICs that lead back from the charging output.

The average life graph of a battery is shown in Figure 1 as related to the EVF battery display. Batteries supplied with camcorders are most often the type rated for one hour of operation before requiring charging. Manufacturers do not always supply two-hour batteries with their camcorders. These can usually be purchased as extras.

When the battery voltage is at 12.3 V or more, the EVF display will indicate a

Battery Voltage	IC1			LED Display	Mode
	2	3	4		
12.3 V or More	L	L	L		Full Power
12.3 V 11.6 V	L	L	H		Normal
11.6 V 10.9 V	L	H	H		Warning Display
10.9 V or Less	H	H	H		Power Off

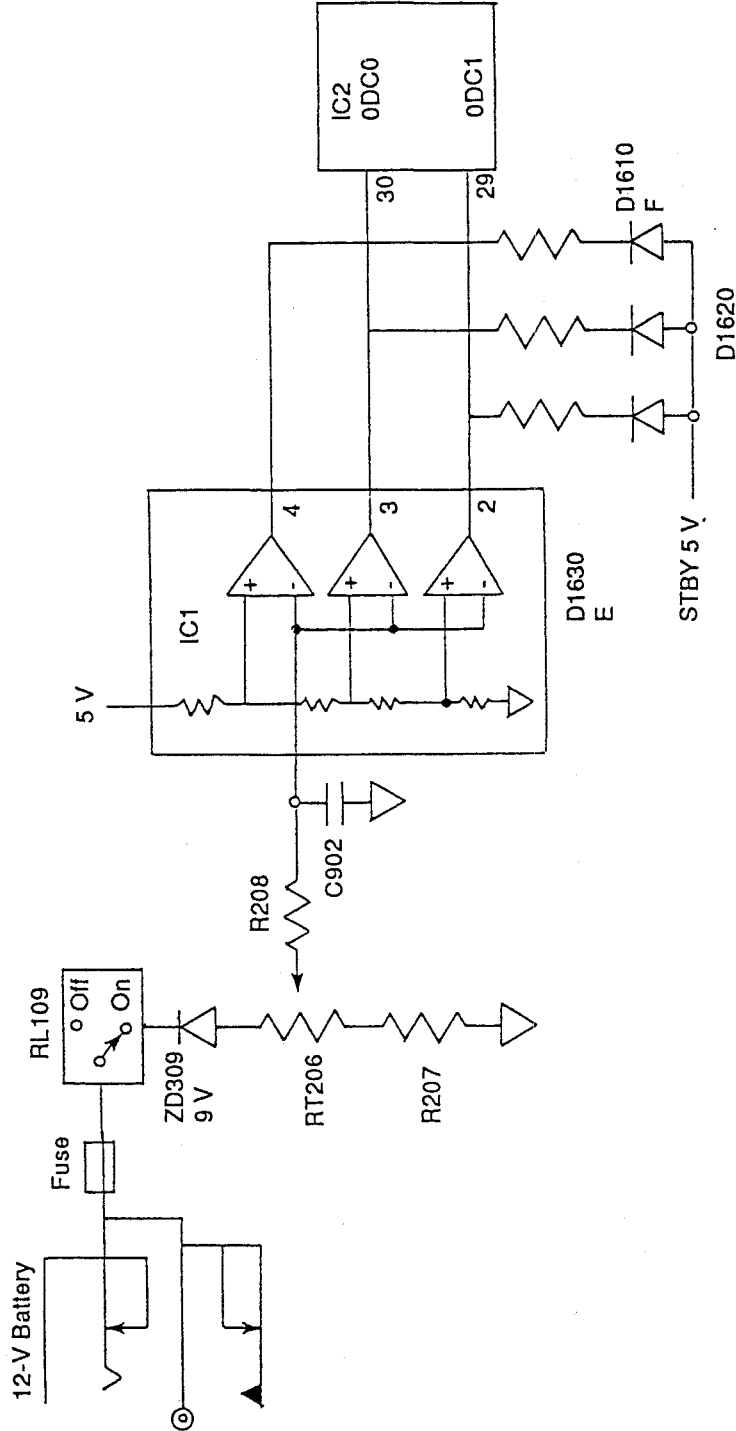


Figure 2: Overdischarge detection circuit and chart

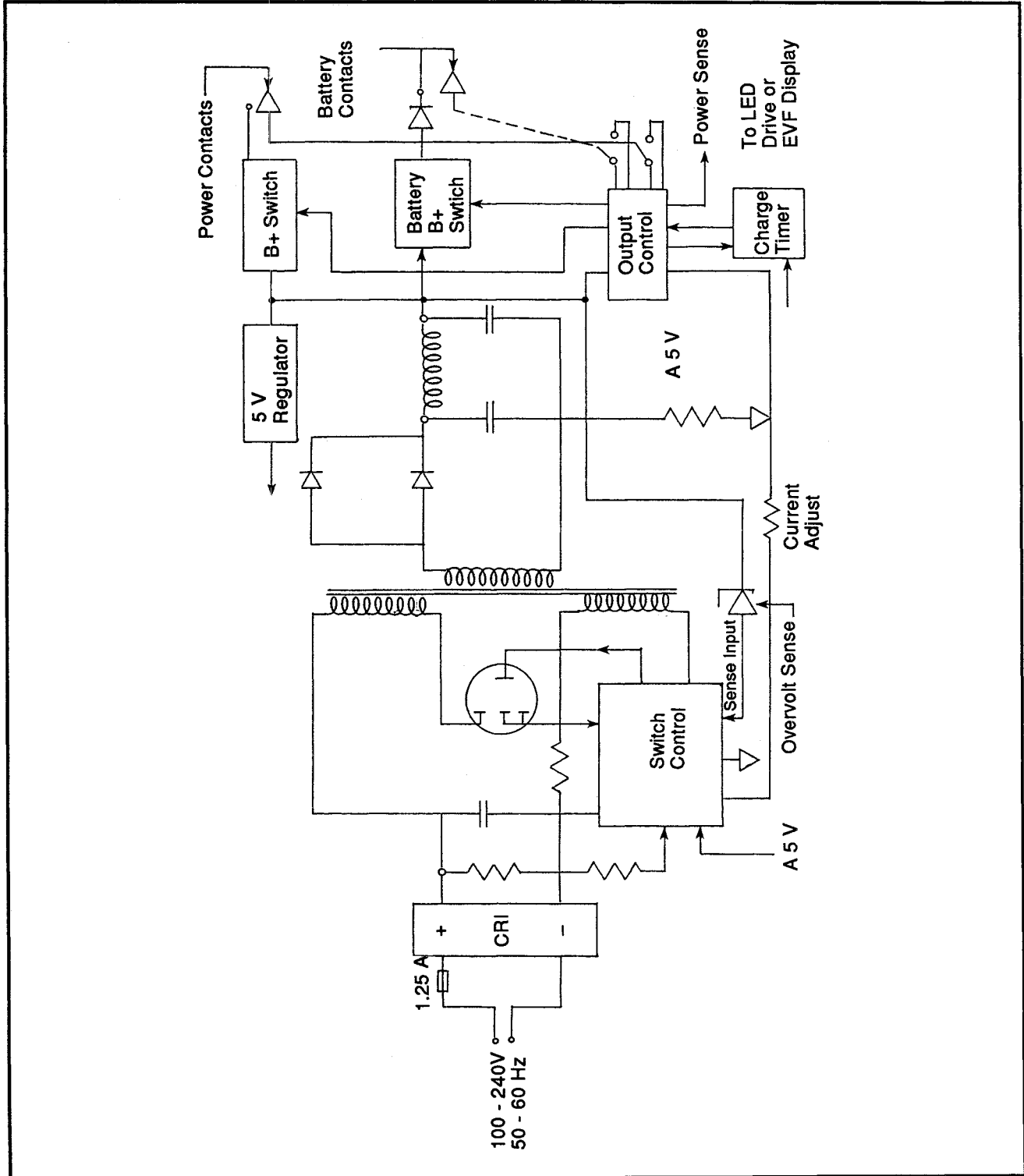


Figure 3: Typical AC adaptor/charger

**5/Cam**  
Camcorder

5/Cam - TR

Troubleshooting and Repair

5/Cam - TR - PS

Power Supplies

full battery, or E—F. When the voltage is between 11.6 V and 12.3 V, the display changes to E—. As the voltage drops to between 10.9 V and 11.6 V, the indicator will be E-, which indicates about 3 to 5 minutes of operation left. When the voltage drops below 10.9 V, the unit shuts down. There is still enough power to eject the tape from the machine.

The camcorder has an overdischarge detection circuit (ODC) as shown in Figure 2. This circuit can be checked by varying the input voltage of the camcorder to the levels indicated and seeing if the display changes according to the chart.



cause a variety of problems. Separate voltage charts may be found in the back of the service manual. These voltages may be broken down as to what voltages occur during what operation (i.e. stop, record, play). Figure 1 shows the typical power distribution of a camcorder.

All power for the camcorder, both the camera and VCR sides is controlled by the power distribution circuits. The power from the battery or AC adaptor enters through the power input junctions. This is a switch-controlled input that allows the camcorder to switch power from the adaptor or battery. In some cases this allows you to charge the battery while using the camcorder.

Note that the 12 V input power will be passed through a fuse to a start-up transistor and applied to a 5 V and a 9 V regulator. The camcorder will turn on momentarily, then go into standby operation. During standby, the relays are inactive (off) and do not allow power to be sent to any of the regulators. This reduces power consumption.

When the Standby/Operate switch is pressed, the relays in the power section will change state and apply power to the various circuits. The output voltages will be 12 V, 9 V and 5 V where needed. The same circuit activates when the Eject button is pushed if the unit is in the standby mode.

If the camcorder does not turn on with the pressing of the Standby/Operate switch, or the Eject button, check to be sure that there is a good input power supply (AC adaptor or battery). Next check to see if the fuse in the power section is not blown. If so, replace it to see if the fuse blows a second time. If the fuse blows a second time, there could be a problem with one of the power section ICs, a diode in the input line to the ICs, or any of the various motor drives.

Check to see if there is power at the control IC when the Standby switch is pressed (refer to the service manual for this chip).

Next, check each regulator and detect whether or not the correct power is exiting the power section. If the regulators are not functioning, suspect a faulty transistor which controls the power sent to the regulators. Check to see if the needed 12 V reach the regulators. If not, suspect a leaky transistor or a relay that is not functioning. (The relay may not be functioning because of a faulty transistor.)

Check to see if the standby line is supplying the 5 V required. If not, then suspect a leaky transistor or diode error. Check the logic of the control IC. If low, the normal mode is activated and all circuits should be operating. If high, check that the switch has been set to the normal or operate position.

**5/Cam**  
Camcorder

5/Cam - TR  
5/Cam - TR - VP  
5/Cam - TR - VP - CC

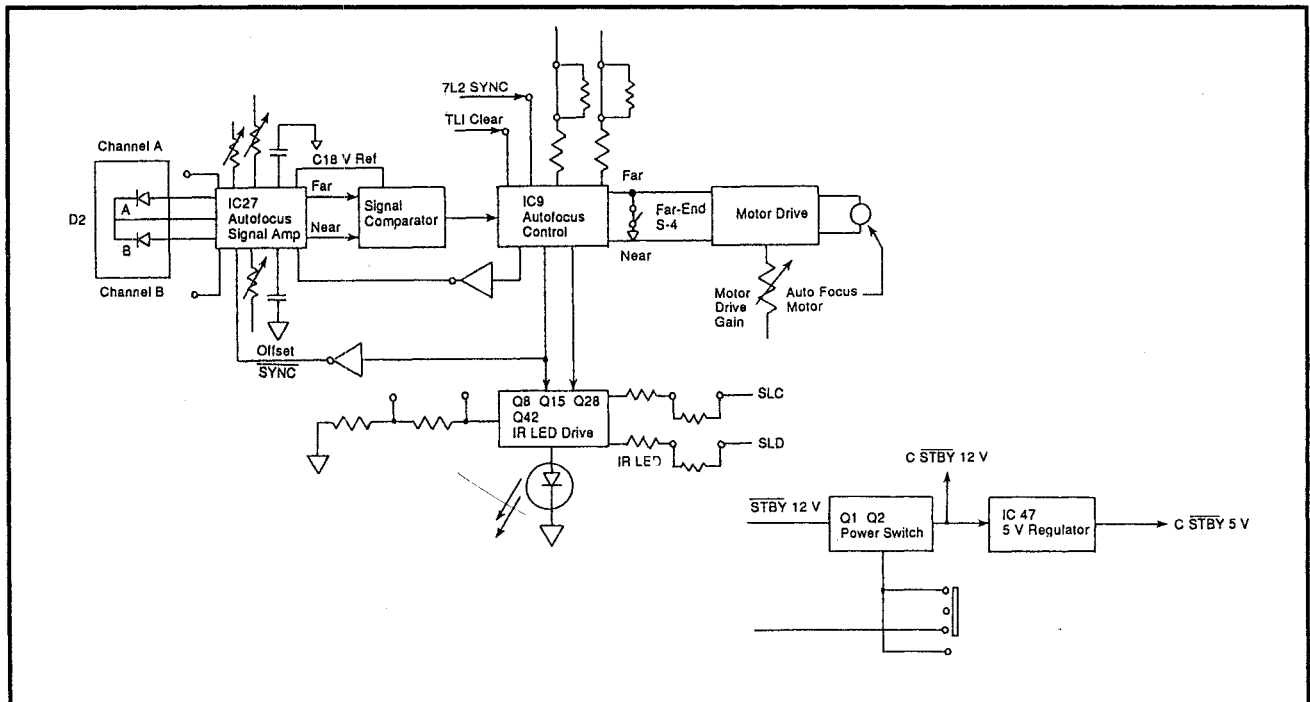
Troubleshooting and Repair  
Video Processing  
Control Circuits

**5/Cam - TR - VP**  
**Video Processing**

**5/Cam - TR - VP - CC**  
**Control Circuits**

**Autofocus Control Circuits**

Figure 1 shows the typical autofocus control circuits. The autofocus control circuit is found in the lens assembly. The circuits use an infrared light (IR) projected through a lens to a full-reflection mirror and then reflected back to a dichroic mirror. The dichroic mirror passes the visible light (picture being shot) to the pick-up and reflects the IR light. The reflected IR is passed to an object, shot through a complex lens, and then reflected back from the object through a condensing lens to a sensor. The two IR sensitive photodiodes in the sensor produce a signal that adjusts the lens focus so that the reflected IR light is equal on both sensor photodiodes. This type of measuring is known as the delta measurement principle.



**Figure 1:** Typical autofocus control circuits

Troubleshooting the autofocus assumes that the focus control works manually. If not, there is a problem within the lens. Begin by making sure the autofocus function is active and the lens cap is off.

The voltage input to the circuit should be checked to see if it is present. If absent, locate the lost signal and repair (it may be a fault switch). Check for the reference voltage of the IC (3 V). If absent the IC may be bad.

Next check to see if there are signals present at the photodiodes. If not present, check to see if the IR LED is getting a signal. If not, suspect a fault in one of the gate ICs.

Continue checking the circuit as referred to in the service manual. Any one of the ICs could be bad. A diode may have failed, or the sensors may be malfunctioning. Replace either the entire board or, (if possible) replace the individual component.

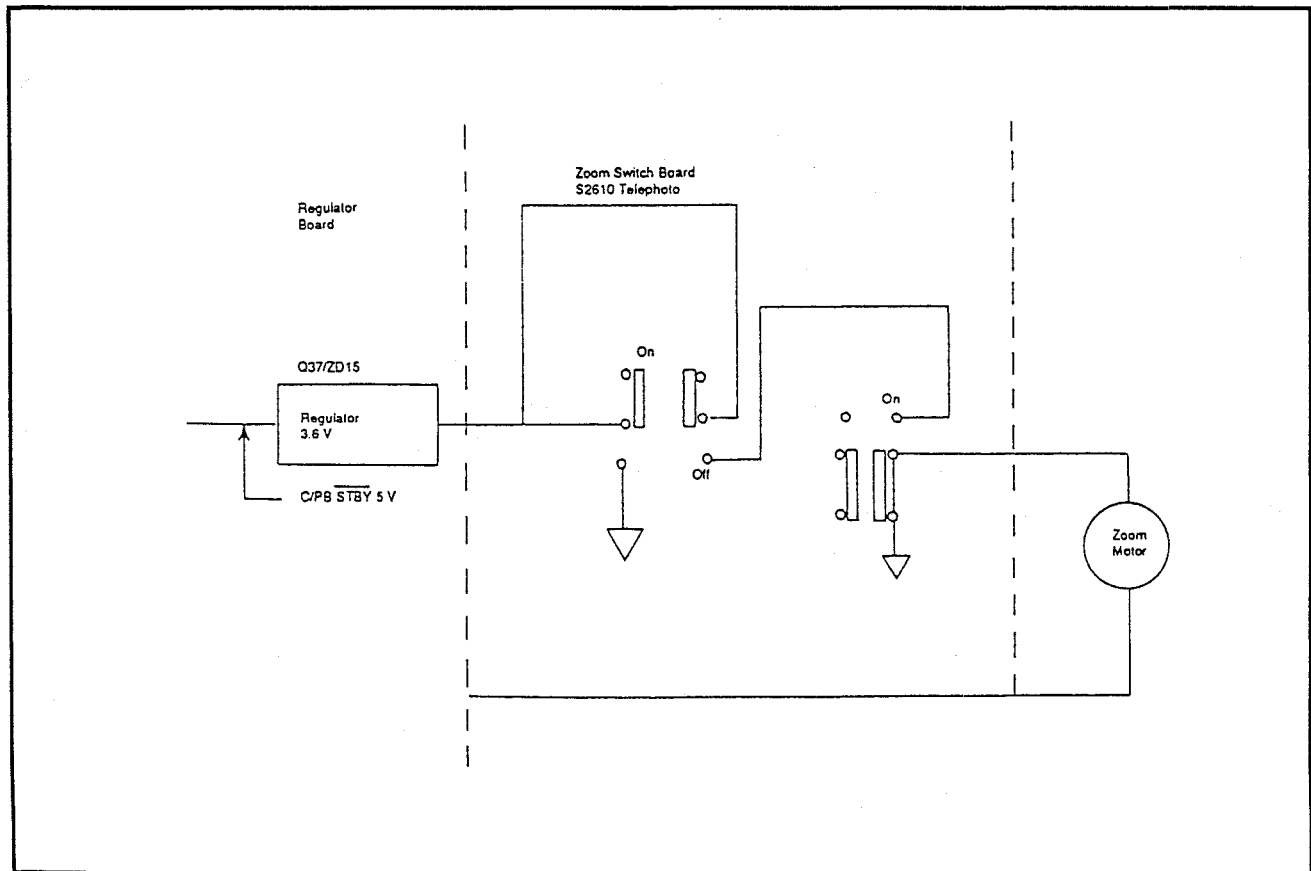


Figure 2: Typical zoom motor control circuit



**Zoom Motor  
Control Circuit**

Depending on which button is pressed, the zoom control motor will rotate the lens in the telephoto or wide angle direction. The zoom control circuit has an onboard voltage regulator (3.6 V) which is used to supply power to the zoom motor. To troubleshoot the zoom control, simply press each of the button directions and see if the zoom motor moves the lens in and out. If it doesn't move, check the wiring between the switches and the motor. Check to see if the gear is making the proper connection. Check to see if the voltage regulator is operating properly.

**Iris Control Circuit**

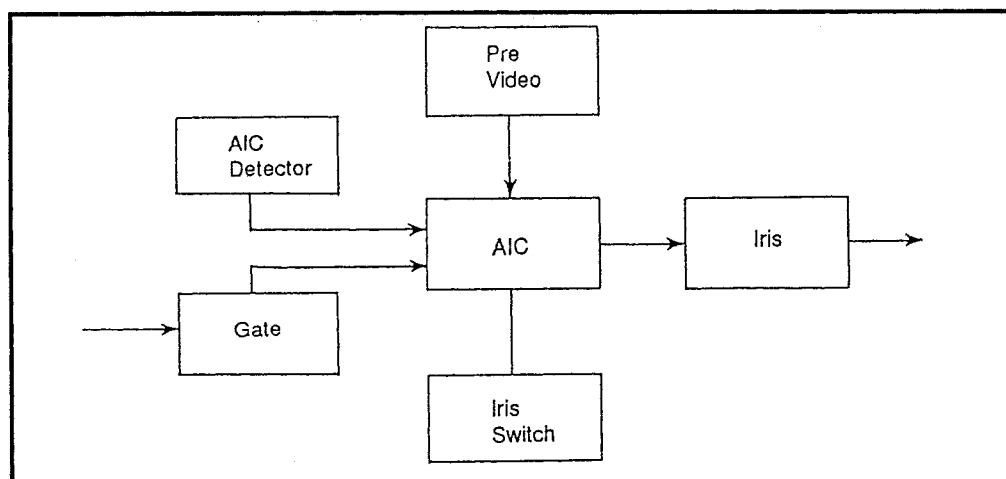
The iris control of modern day camcorders works similar to the camera aperture. Within the iris mechanical system section is the auto iris circuit (AIC).

The auto iris circuit operates the lens iris in order to maintain an average video level. Figure 3 shows a block diagram of the AIC. The Y-signal from the dark-clip circuit is applied to a filter composed of a capacitor and variable resistor. The average level of the Y-signal is amplified in the AIC IC which is based on the reference voltage at the inverting input. The reference voltage is a combination of feedback from the iris motor and the voltage set by the AIC control resistor (the external iris control) and the internal preset resistor.

As the average lighting of a scene decreases, the Y-signal output also decreases. The iris motor is opened/closed by the difference between the reference voltage (9 V) and the output of the motor driver. When the average motor driver output increases, the iris will close.

**White Balance  
Circuit**

These white balance circuits control the gain of the R and B signals to produce a proper white. Equal amounts of red, blue, and green are needed to produce proper white.



**Figure 3:** Block diagram of a typical auto iris circuit (AIC)

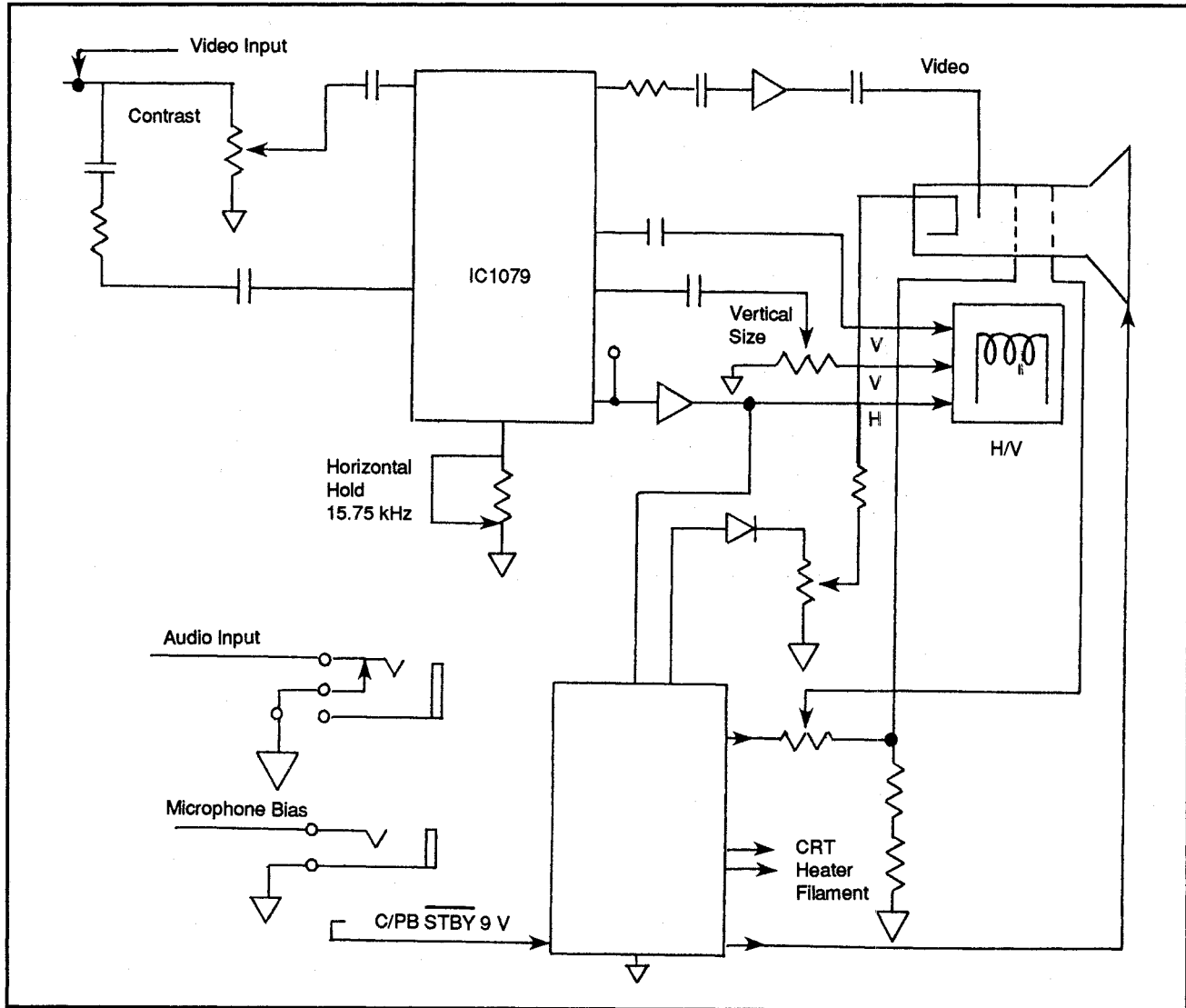


Figure 4: Typical electronic viewfinder circuits

### Electronic Viewfinder Circuits

Figure 4 shows a typical viewfinder circuit (EVF). The EVF is like a small black-and-white video monitor that displays images from the camera and the VCR of a camcorder. The EVF also is used for on-screen displays like time/date and status of the VCR's operation.

User controls available on the EVF can adjust brightness, contrast and focus. On the circuit board you can adjust the horizontal and vertical controls.

Most of the controls for the EVF are controlled by a single IC. Any adjustments

to this IC other than input adjustments are impossible. Replacement of the entire circuit board is the best way for repairing the EVF.

The EVF adjustments include the horizontal hold, picture tilt, EVF centering magnets, vertical size, focus, contrast and brightness.

To align the EVF horizontal hold, connect a frequency counter to the horizontal output of the main IC. Connect a 47  $\mu\text{F}$  16 V electrolytic capacitor between ground and the video input line.

Adjust the horizontal hold control for  $15.75 \pm 0.1$  kHz. Disconnect the capacitor from the video line.

Figure 5 shows the holding screw for the deflection coil and the EVF centering magnets. Focus the camera on an alignment chart like the cross hatch chart. Both the chart and the camera should be level. Loosen the deflection coil holding

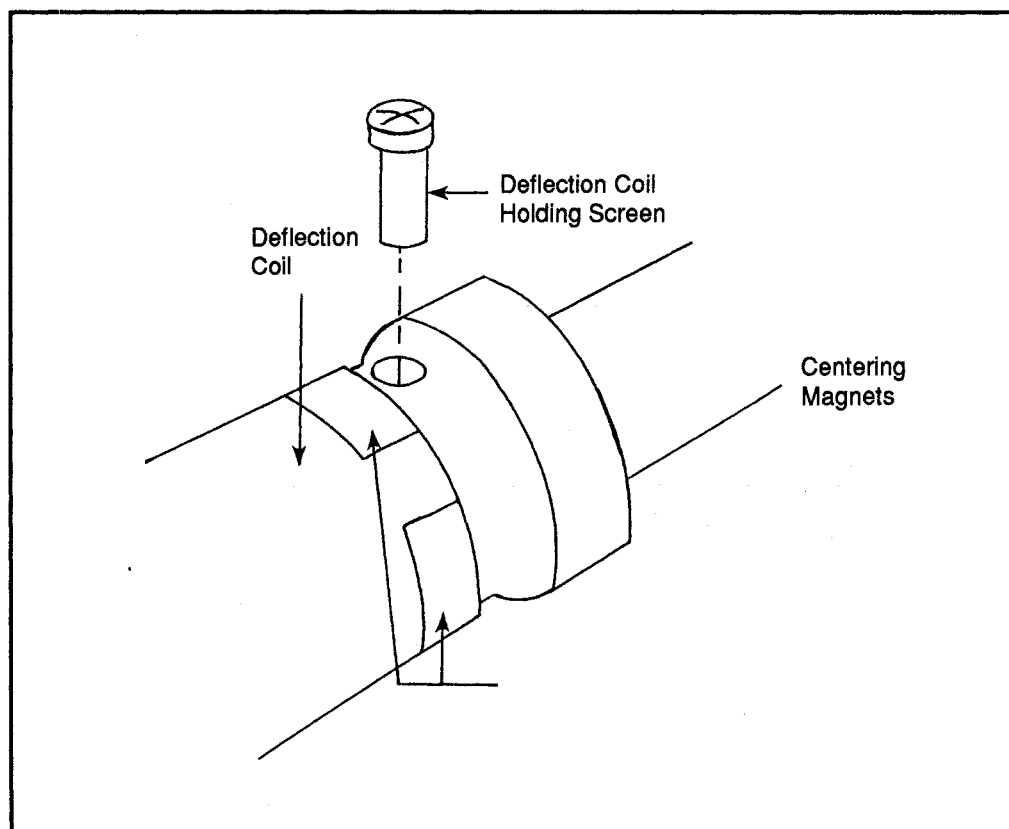


Figure 5: Deflection coil holding screw



5/Cam - TR	Troubleshooting and Repair
5/Cam - TR - VP	Video Processing
5/Cam - TR - VP - CC	Control Circuits

screw. Turn the deflection coil until the image is straight. Tighten the screw.

The EVF centering magnets align the position of the image being viewed on the EVF display screen. Fill the screen with the test chart. Adjust the centering magnets until the center of the picture is in the center of the EVF.

To set the vertical size adjustment, focus the camera on a circle. Adjust the vertical deflection size until the circle is round. To set the EVF focus, aim the camera at a resolution chart or siemens star chart. Adjust the focus control for best focus on the EVF screen. To set the EVF contrast and brightness controls, aim the camera at a gray scale chart. Adjust the brightness control and the contrast control so the gray scale on the EVF closely matches the actual gray scale.

# 5/Cam Camcorder

5/Cam - TR	Troubleshooting and Repair
5/Cam - TR - VP	Video Processing
5/Cam - TR - VP - R	Recording

## 5/Cam - TR - VP Video Processing

### 5/Cam - TR - VP - R Recording

#### Lens Assembly

Within the lens assembly is the focus ring, zoom ring, iris, and exit or lens back block. The lens on a camcorder is typically a 6-to-1 zoom lens with a macro function. The zoom control can be manual or motorized. When the zoom control is operated, a lens moves inside the lens housing away from, or closer to, the primary focusing lens. This changes the magnification of the lens and allows for zoom and telephoto operation. The lens assembly when damaged must be replaced as a whole if damaged.

#### Creating the Picture

Light passes through the lens assembly and focuses on the pick-up element (either tube or chip). Home camcorders use a single pick-up element. Professional equipment will use two or three pick-ups. Either way, the pick-up creates the primary colors for a color picture. The incoming light is divided into the primary colors by means of a stripe filter between the lens and the pick-up element. Figure 1 shows the composition of a typical stripe filter.

When an incoming signal passes the diamond section of the filter, all light is allowed to pass ( $R+G+B = Y$ ). When the light crosses the yellow stripe, red and green signals are created, but not blue. When the light crosses a cyan stripe, blue and green signals are processed, but not red. When the light passes an area where the yellow and cyan stripes cross, the yellow stripe blocks blue and the cyan stripe blocks red, allowing only green to pass. The levels for R and B are varied. The time needed for horizontal scanning produces a  $90^\circ$  delay in the phase of succeeding lines. The output from later lines is phased with those of earlier lines by using delay and phase-shifting circuitries.

These lines are shown as N, N+1, and N+2 in Figure 1. The N line contains varied red and blue signals and a constant green signal. By subtracting R for the B + R signals, only the B component passes. Subtracting the R signal leaves a B signal only. The green level is constant and the red and blue signals are varied. This allows the luminance signal Y to be combined with the R and B outputs. The output for NTSC (National Television Systems Committee) color is then R - Y and B - Y. As the target screen of the pick-up device is scanned, different output signals are created. The filter allows only certain colors to pass.

**5/Cam**  
Camcorder

5/Cam - TR

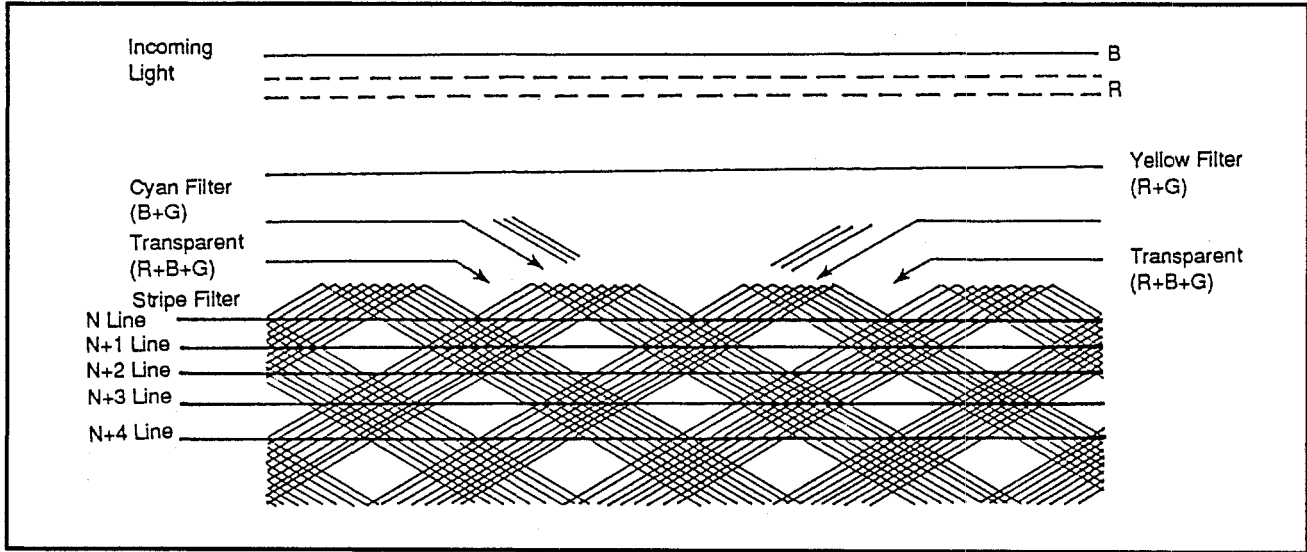
Troubleshooting and Repair

5/Cam - TR - VP

Video Processing

5/Cam - TR - VP - R

Recording



**Figure 1:** Stripe filter characteristics and related signals

# 5/Cam Camcorder

5/Cam - TR	Troubleshooting and Repair
5/Cam - TR - VP	Video Processing
5/Cam - TR - VP - SC	Sensor Circuits

## 5/Cam - TR - VP Video Processing

## 5/Cam - TR - VP - SC Sensor Circuits

- Trouble Sensors** If the camcorder will not go into any of the modes (play, record), check the sensor circuits for all correct signals. If either the forward end or rewind end pins of the function sensor IC are high, the tape may be at the end or beginning and cannot advance in that direction. If the tape is inserted and is ejected or stops without loading, the signal pulse at the reel lock pin may be incorrect.
- Reel Sensors** The reel sensor is made from an LED, photo sensor and a reflective disc with eight reflective and nonreflective areas located on the underside of the takeup reel. As the reel rotates, the LED output is reflected/absorbed by the rotating disc which produces a signal by the photo sensor. Voltage pulses are generated by this as on/off signals via reflected/absorbed light and sent to the sensor IC. If the reel stops rotating, the pulses are removed, and the IC sends the stop signal. The pulses are used to feed the tape counter.
- Cassette Switch** The cassette-up switch will be hooked to the function sensor IC circuit to detect when a cassette is loaded or if the unit is empty. When the cassette door is open, the cassette switch is open and the function sensor IC senses this.
- Record Tab** If a record tab has been punched on a video cassette, the safety tab switch will not be activated. This produces a low at the safety tab pin of the function sensor IC and will not allow the camcorder to enter the record modes.
- Mode Sensor Switch** The Mode Sensor Switch checks that the various functions are working properly. It checks to see if the VCR is executing the selection function. It can also tell the camcorder a tape has been unloaded and stop the camcorder.
- The mode indicator drive signals from the sensor circuits are applied to various character displays to indicate what mode is being operated. For example, if the current mode being operated is rewind, the mode signal will be applied to the proper transistor, which sends the signal to the proper display. (On older camcorders, on-screen displays may not be used, but a series of LEDs may indicate mode selections. Here we are talking about EVF displays only.)

# 5/Cam

## Camcorder

5/Cam - TR	Troubleshooting and Repair
5/Cam - TR - VP	Video Processing
5/Cam - TR - VP - SC	Sensor Circuits

If the display is not indicating (REW appears in the EVF) make sure the function is being executed (rewind, play, etc.). If the function is working, the problem may be that the display alignment is off. If the alignment is correct, then the mode indicator circuits are bad.

### Cylinder Lock Detection

The cylinder lock signal is the 30 Hz signal used by the cylinder servo. This signal detects the pulse width and if this value is less than a particular value, it indicates that the cylinder motor has slowed down or stopped. If this occurs, the sensor circuit will put the camcorder in the stop mode.

### Dew Sensor

The dew sensor detects the presence of moisture in the VCR section of the camcorder. As moisture builds up on the sensor element, a signal is increased and sent to the trouble sensor IC. When a high enough level is reached, the sensor circuit will place the VCR in standby and display the word DEW in the EVF.



**5/Cam  
Camcorder**

5/Cam - TR	Troubleshooting and Repair
5/Cam - TR - VP	Video Processing
5/Cam - TR - VP - SPC	Signal Processing Circuits

**5/Cam - TR - VP  
Video Processing**

**5/Cam - TR - VP - SPC  
Signal Processing Circuits**

The signal processing circuit (VHS camcorder) may consist of the CCD image pick-up devices, preamplifier, resampling, and chrominance and luminance circuits.

**Luminance  
Processing**

Figure 1 shows a typical luminance signal processing circuit. The luminance circuits are designed to separate the luminance signals and form the composite video signal.

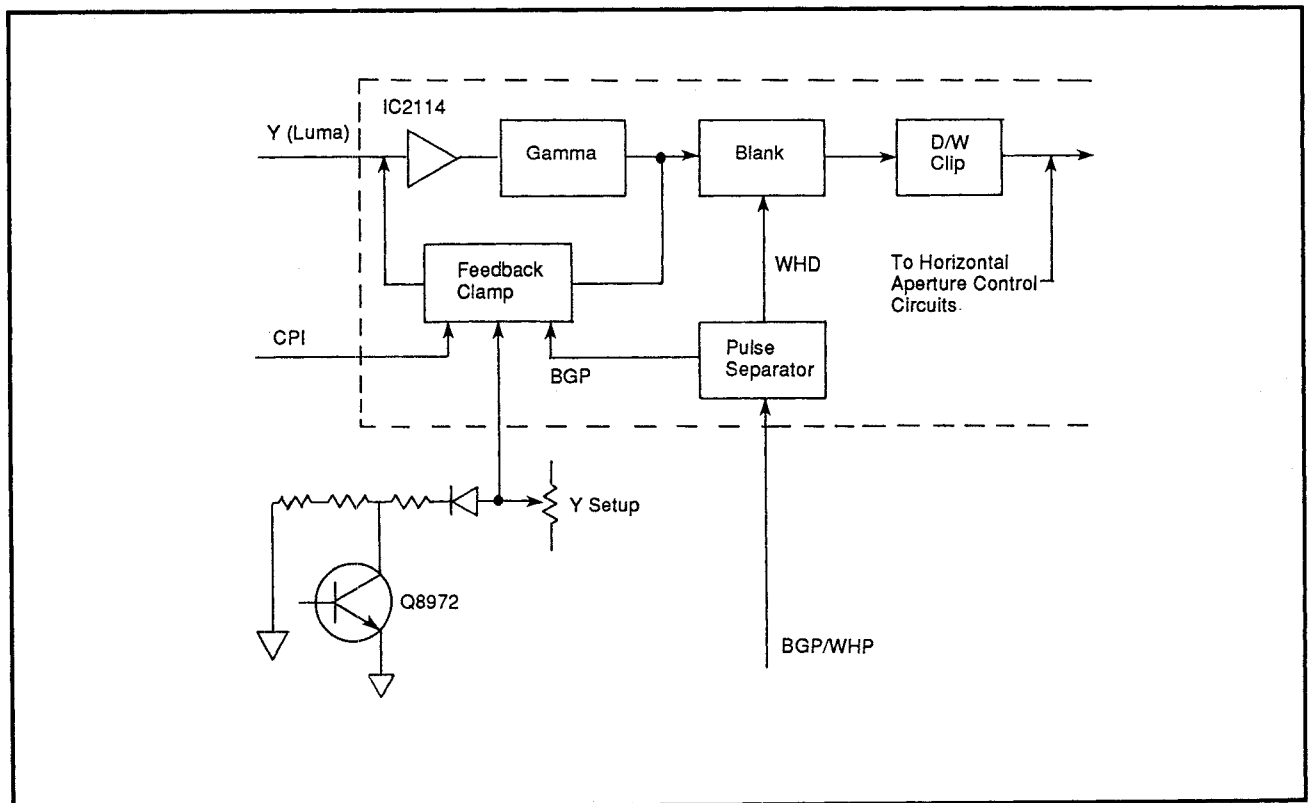


Figure 1: Typical luminance signal processing circuit

# 5/Cam Camcorder

5/Cam - TR	Troubleshooting and Repair
5/Cam - TR - VP	Video Processing
5/Cam - TR - VP - SPC	Signal Processing Circuits

The luminance circuit consists of a shading correction, setup, feedback clamp, blanking, linear clip, AGC, AGC detector, gamma control circuits, gamma correction, and a blanking and linear clip section. These circuits produce the luma (Y-signal) in the AIC/AGC circuits and apply the processed signal to the chroma encoder.

The Y-signal is branched into two paths from the dark/white clip circuit. One path is sent to the aperture amplifier and the other is delayed (150 ns) and then applied to the aperture amplifier. The output is a resultant signal that is the low-frequency luminance signal.

## Chroma Processing

The chrominance signal-processing circuits receive R and B inputs and a low frequency luminance (YL) input. The circuit generates two color difference signals, -R-YL and -B-YL. These signals are then applied to the automatic white-balance circuits and the chroma encoder. The chroma signal processor circuit also creates a clipped -R-YL signal that is applied to the horizontal aperture correction circuit.

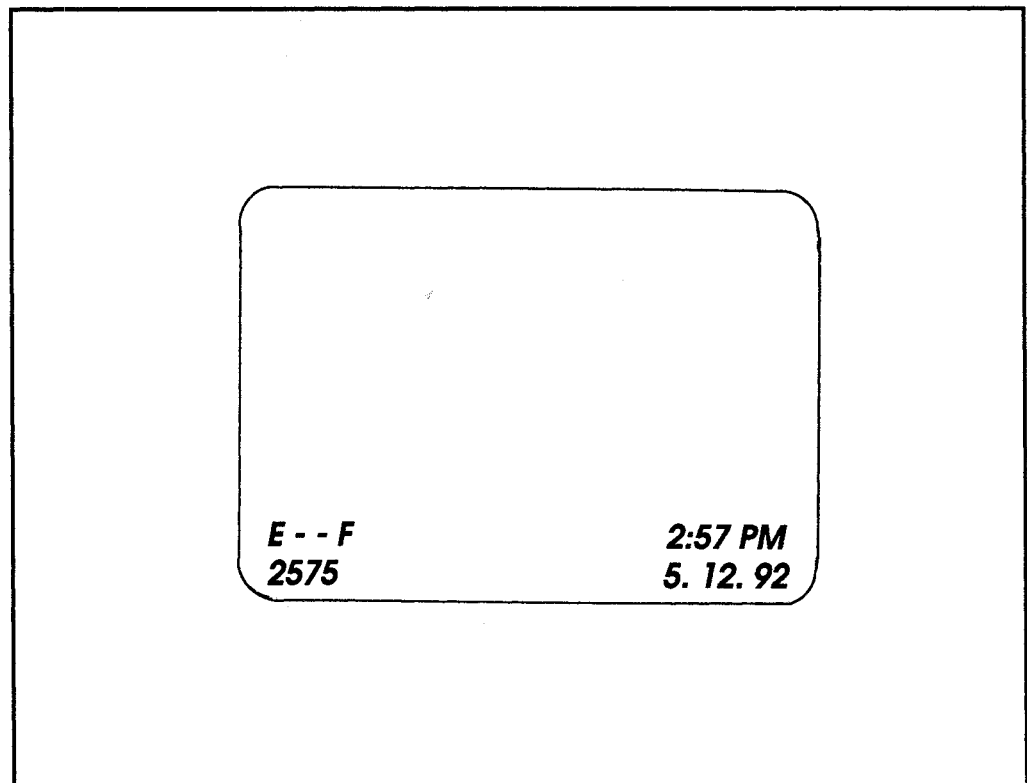
**5/Cam**  
Camcorder

5/Cam - TR	Troubleshooting and Repair
5/Cam - TR - VP	Video Processing
5/Cam - TR - VP - TCC	Tape Counter Circuits

**5/Cam - TR - VP**  
**Video Processing****5/Cam - TR - VP - TCC**  
**Tape Counter Circuits****Location**

Figure 1 shows a typical tape counter section. The tape counter section is located in a single module. The power is derived from a 3 V to 5 V source.

The pulses used to advance the tape counter are received from the sensor section. The output is an on-screen display in the viewfinder.



**Figure 1:** Typical on-screen tape counter display

# 5/Cam Camcorder

5/Cam - TR	Troubleshooting and Repair
5/Cam - TR - VP	Video Processing
5/Cam - TR - VP - TCC	Tape Counter Circuits

## Truth Table

Camcorder Mode	Counter Input 1	Counter Input 2	VCR Mode
Stop	1	1	Stop
Play/FF	1	0	Count up
Rewind	0	0	Count down

Figure 2: Truth table for display

## Capacitance

When power is first applied, the display memory is erased and the display shows 0000 (assuming the display mode has been selected).

There is a coupled capacitance to keep the counter settings during a momentary loss of power or when the unit has been turned off. In some units the capacitance can keep the circuit active for about 3 hours.

## Memory

If the save function has been activated (by power applied from the sensor section) memory contents can be saved for several days or until the power is removed from the camcorder.

The display section also receives two control pulses at the control inputs from the sensor control section. These inputs control the mode of operation (count up, count down, play, memory, etc.) as shown in Figure 2.

If the Memory button is pushed, an M appears on the display and it can be reset to 0000 during a rewind or fast-forward function.

## Controls

The display section generates a low when the counter reaches 0000. This low will then be returned to the sensor section which then puts the VCR in the stop mode.

The Reset button clears the display (in the same manner as when the unit is first powered up) by sending a pulse to the clear input of the display control section.

If problems arise in the tape counter display, check to see that all signals are reaching the display control section (including the power input).

If all the inputs are correct, but the display is absent, the control IC is not functioning correctly or the character alignment is set wrong and needs adjusting. This would put the characters somewhere off screen.

**5/Cam**  
**Camcorder**

5/Cam - TR	Troubleshooting and Repair
5/Cam - TR - VP	Video Processing
5/Cam - TR - VP - TCC	Tape Counter Circuits

Alignment of the character positions is described in “*5/Cam - TR - EA Electrical Adjustments*”.

If the display is present (and all inputs are correct) but the counter does not advance/decrease during any of the movement modes, the display control IC could be bad.

When any one of the input lines is absent or abnormal, trace the signal back to its source.

**5/Cam**  
Camcorder

---

5/Cam - TR	Troubleshooting and Repair
5/Cam - TR - VP	Video Processing
5/Cam - TR - VP - TCC	Tape Counter Circuits

---

# 5/Cam Camcorder

5/Cam - VCS

Various Case Studies

5/Cam - VCS - Sha-VL-L285U

Sharp VL-L285U

## 5/Cam - VCS Various Case Studies

### 5/Cam - VCS - Sha-VL-L285U Sharp VL-L285U

#### Introduction

This camcorder has all the standard features and a few more. One nice feature is the color viewfinder. Most camcorders use a black & white viewfinder, which shows the user what is being recorded and gives an indication of contrast. However, a black and white viewfinder does not help when adjusting the color manually, nor does it give accurate information about color shifting in low or unusual lighting situations.

Another nice feature rarely found in camcorders is a built-in self timer. This allows the user to set up the camcorder and step into the picture. The camera will activate automatically.

Using the camcorder and performing routine maintenance are the same as with any camcorder. Generally, access to the interior is difficult. Because of this, most users and many technicians will give only a cursory cleaning and almost no other maintenance.

This Sharp camcorder offers much easier access to the interior than most camcorders. The cassette door is held in place by two screws. A light tug upwards and out will remove the door and provide access to the interior.

#### Overview

The Sharp VL-L285U is a full-sized camcorder that accepts standard VHS cassettes. The overall dimensions are 5 13/16" x 9 5/16" x 16 3/8", with a weight of 6.2 pounds (plus another 1.6 pounds for the battery pack).

It has a 1/2" CCD pickup capable of 270,000 pixels and is sensitive to 2 lux. The viewfinder is a 1" color LCD with an adjustable lens to change the diopter setting (for using the camera without glasses).

The lens is F1.6 with a 12X power zoom. The filter size is 55 mm. An electronic shutter can be selected to provide shutter speeds of 1/500, 1/1000 or 1/2000. When the amount of light is sufficient, this feature can be used to "freeze" a moving subject.

# 5/Cam

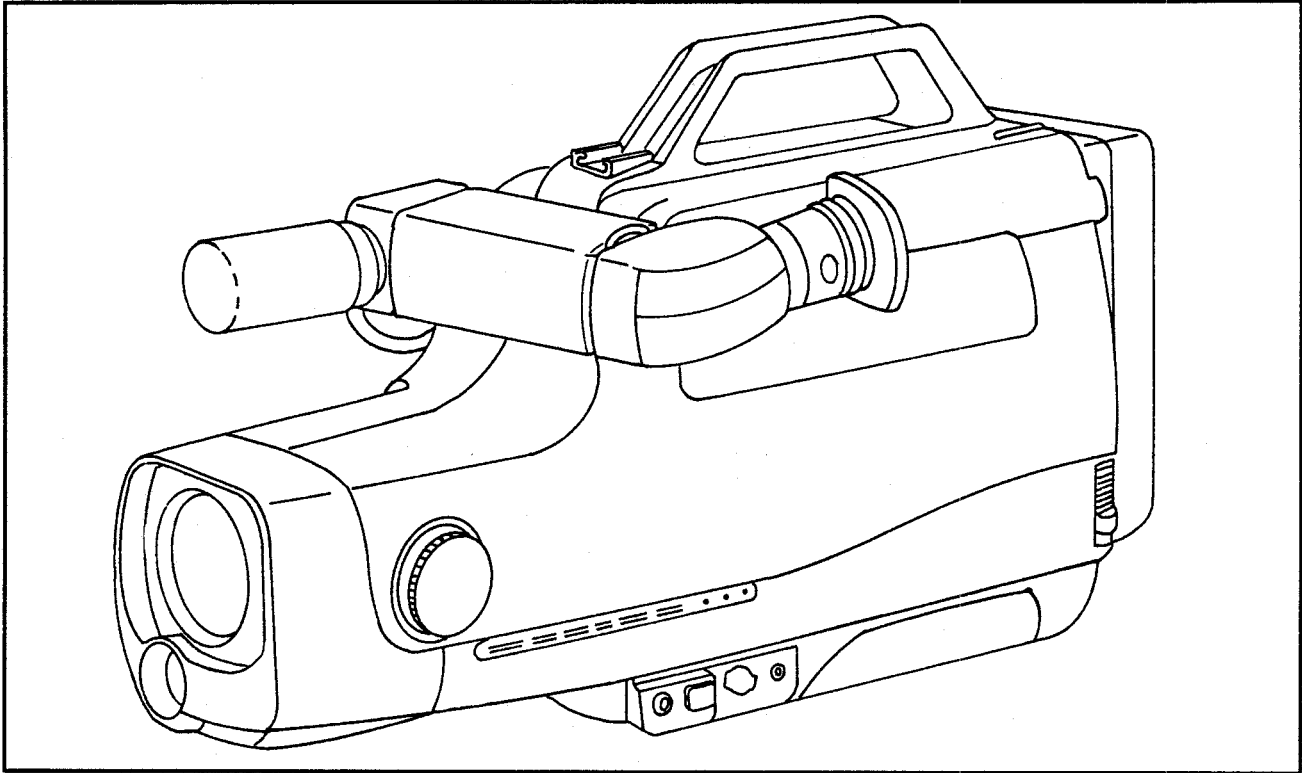
Camcorder

5/Cam - VCS

Various Case Studies

5/Cam - VCS - Sha-VL-L285U

Sharp VL-L285U



**Figure 1:** The Sharp VL-L285U

### Microphone

The microphone that comes with the unit is an omnidirectional electret condenser type with a 3.3 mm plug. The unit has a microphone input of -62.8 dBs into 18 kW.

Video output is a composite signal at 1.0 V peak-to-peak into 75 W. The audio output is -8 dBs at 308 mV into less than 600 W.

### Playback/Record

Playback and record are both SP (standard play), giving 2 hours of recording or playback with the standard T-120 cassette, and 160 minutes with the T-160 cassettes. It should be noted that the longer play cassettes are made with a thinner base and may cause trouble. This becomes more of a problem if the tape is used in a poorly maintained VCR or camcorder. If you use the longer tapes, it's critical that you keep the unit clean.

### Flying Erase Head

Playback/recording is enhanced by the use of a flying erase head. Because the erase head is mounted on the video drum assembly and turns with the record heads, the number and severity of glitches is greatly reduced.



The unit uses 12 VDC and consumes 12 W of power in operation. Power can be supplied through an AC adaptor/charger, an onboard nicad battery pack (BT-22) or from the 12 VDC supply of an automobile (with the optional adaptor cable). The AC adaptor/charger (UADP-0104GEZZ) accepts an input voltage of between 100-240 VDC and outputs at 13 VDC and 1.2 A. The adaptor/charger consumes up to 30 W of power.

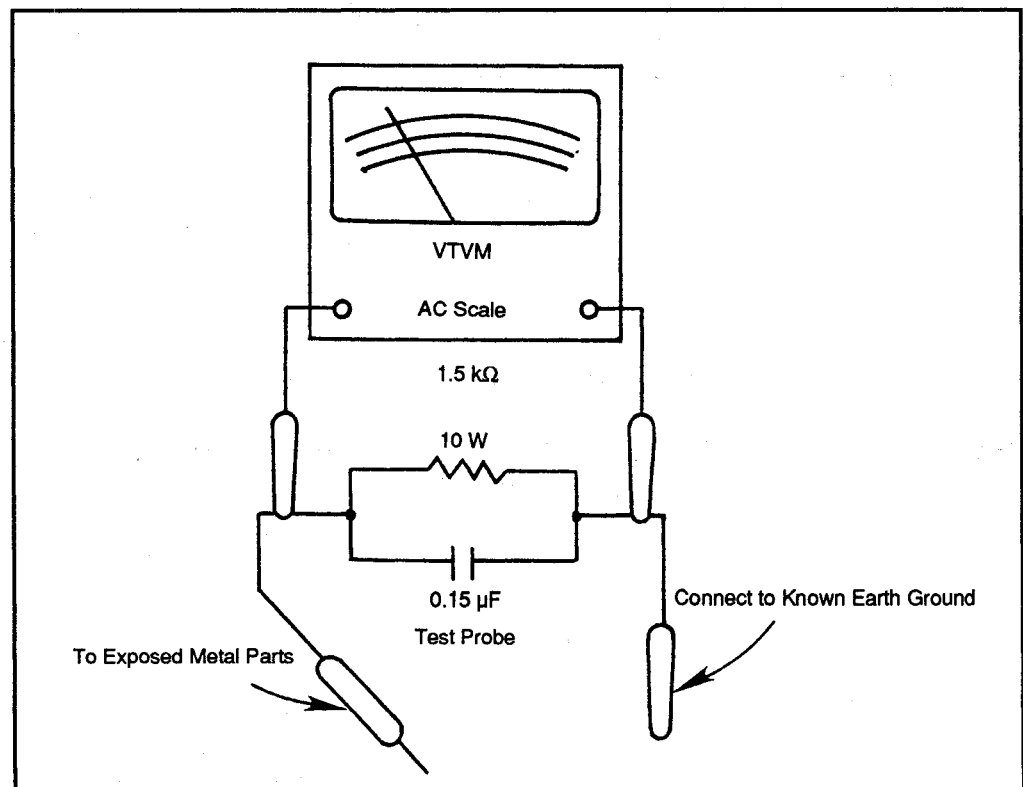
**Warning!**

*If extensive disassembly and/or repairs have been done, it's important to be sure that the unit is safe before putting it back into service. Thoroughly examine all work done. Be especially careful of any wiring, and particularly wires that carry AC voltage.*

**Current Testing**

Sharp suggests that you complete the examination by using a VOM or DMM to test for any leakage current greater than about 0.45 VAC rms. This is the equivalent to a leakage current of 0.3 mA rms. A leakage current at this level or greater can present a shock hazard to the user.

Begin by connecting a 10 W 1.5 kW resistor in parallel with a 0.15  $\mu$ F capacitor.



**Figure 2:** Arrangement to test for possible current leakage

# 5/Cam

## Camcorder

5/Cam - VCS

Various Case Studies

5/Cam - VCS - Sha-VL-L285U

Sharp VL-L285U

Clip the meter probes to this network. Then clip one side to a known ground. The other side will be used to probe the various conductive points in the camcorder (see Figure 2). This includes any metal parts such as the metal parts of the cabinet, screws, shafts for knobs and other controls.

### Voltage Drop

In essence you are testing the voltage drop across the resistor (which is in series with the meter). Attach the AC adaptor to the camera, turn on the power and make the tests. It is best to run through the testing a second time with polarity reversed. That is, use a non-polarized adaptor for the plug so that it can be reversed in the outlet.

### General Disassembly

The extent of disassembly depends entirely on the problem and the job at hand. It is suggested that you keep it to a minimum and do no more than is absolutely essential. The main disassembly information is placed here, in one place, to make finding it easier. This does not mean that you should disassemble the entire unit, only what is necessary. Although disassembly and reassembly of this Sharp camcorder is relatively uncomplicated (compared to some other units), there can always be difficulties. Keep in mind at all times during disassembly that you should never force anything.

General disassembly begins with the removal of the viewfinder assembly. To do this, simply unplug the connector and slide the assembly off the shoe.

### Removal

Next, remove the cassette door. To do this, first remove the two holding screws. The door comes off by lifting it and pulling outwards. This is an important step since it gives you good access to the interior. (Note: If you are removing the door only to service the interior, it is not necessary to remove the viewfinder assembly.)

To access the lens assembly, remove the two screws—one from the front and one beneath. The front cover is removed by pulling it forward.

### Cabinet Removal

You can now remove the cabinet. This will give you access to the rear of the VCR assembly. Remove the three holding screws—one at the top rear and two beneath the camcorder. Flip up the VCR control panel door. Unplug the battery terminal connector (inside at the upper rear) and remove the cabinet.

The control assembly can now be taken off. Remove the holding screw and slide the assembly sideways.

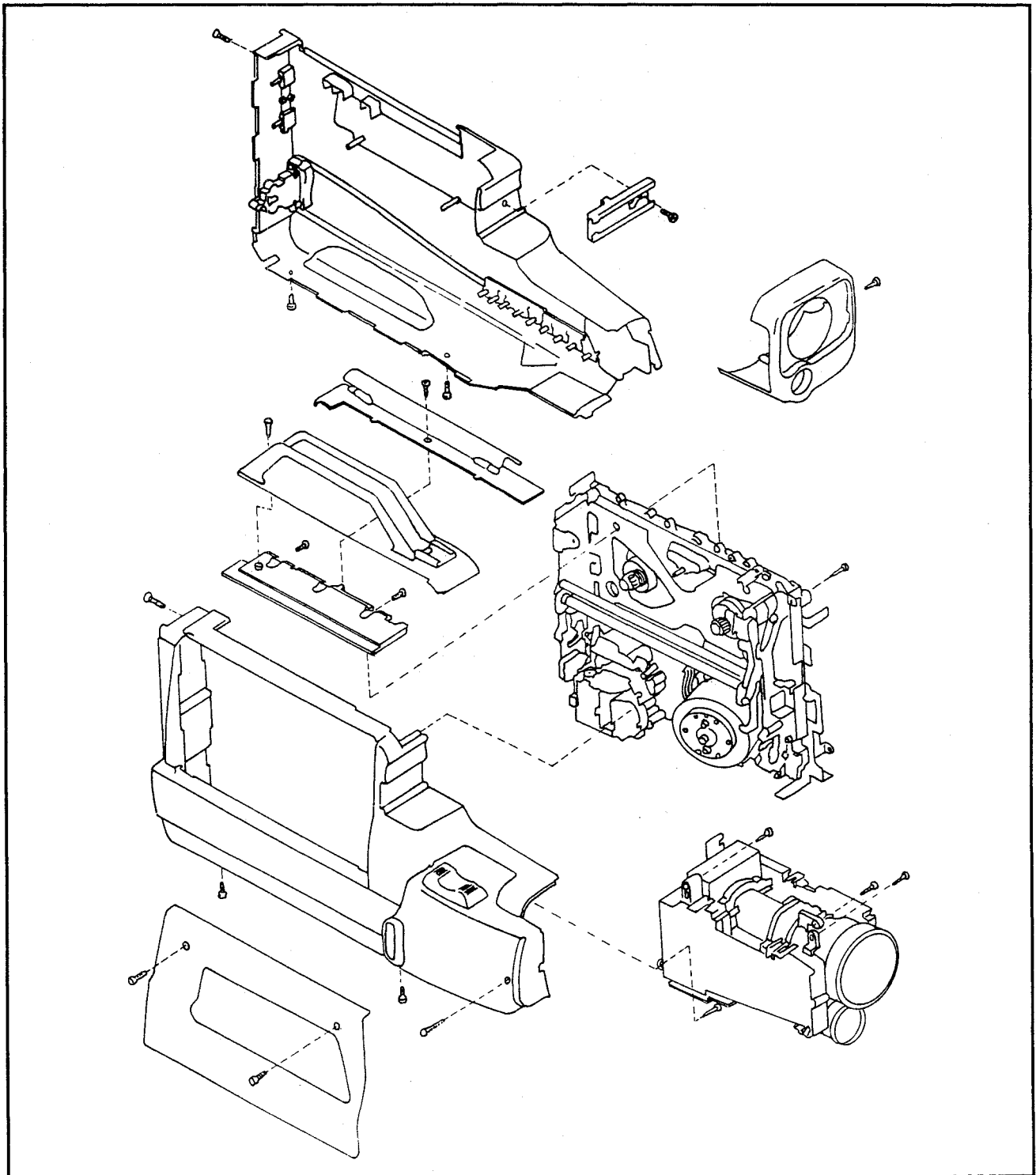
**5/Cam**  
Camcorder

5/Cam - VCS

5/Cam - VCS - Sha-VL-L285U

Various Case Studies

Sharp VL-L285U



**Figure 3:** General unit disassembly

# 5/Cam

## Camcorder

5/Cam - VCS

Various Case Studies

5/Cam - VCS - Sha-VL-L285U

Sharp VL-L285U

The camera unit is held by four screws. Two are at the front top; the other two are at the back—one above and one below. Remove these screws. Carefully disconnect all wires going to the camera unit. These wires tend to be delicate, so proceed cautiously.

### VCR Unit

The VCR unit is held in place by four screws. Two come up through the bottom of the unit. Another goes through the cabinet at the top rear. The fourth screw goes through the VCR unit at the front and top. As with the camera unit, very carefully disconnect all wires and connectors. The VCR unit can now be lifted out.

### Handle Removal

At this point disassembly is essentially complete. If need be (rare) you can also remove the handle. This is done by removing the screw at the rear of the handle. Then push the handle forward slightly and lift. The cabinet holder is held by two screws passing through the side.

Reassembly is the reverse procedure. Take care that you replace all the wires and connectors correctly. Double check this, and the placement of each screw during each step.

### Viewfinder Removal

In most cases, if the viewfinder unit malfunctions it will be replaced as a whole unit. Working inside the unit is difficult and delicate. Some of the parts, most notably the LCD module and the fluorescent viewfinder tube, can be easily damaged.

If disassembly is required, proceed cautiously. Work close to the surface of the workbench. (If something accidentally falls, you want the force of impact to be minimal.) If you intend to work with or around the LCD module, be aware that it is extremely delicate. Even touching it can destroy the module. It has a built-in driver which is highly sensitive to static. There are also four bonded connections on the unit which are delicate enough that even touching them can cause a break.

If you must work with or around this module, take precautions. It's best to ground yourself so as to drain off any static buildup. Touch the module as little as possible. Don't touch the bonded connections or the terminals on the flat cable at all! (Further precautions will be given in this section at the appropriate time. For now this is mostly a warning to avoid working around the LCD module if at all possible.)

Begin by removing the viewfinder unit from the camera. To do this unplug the connector and slide the viewfinder unit off the camera.

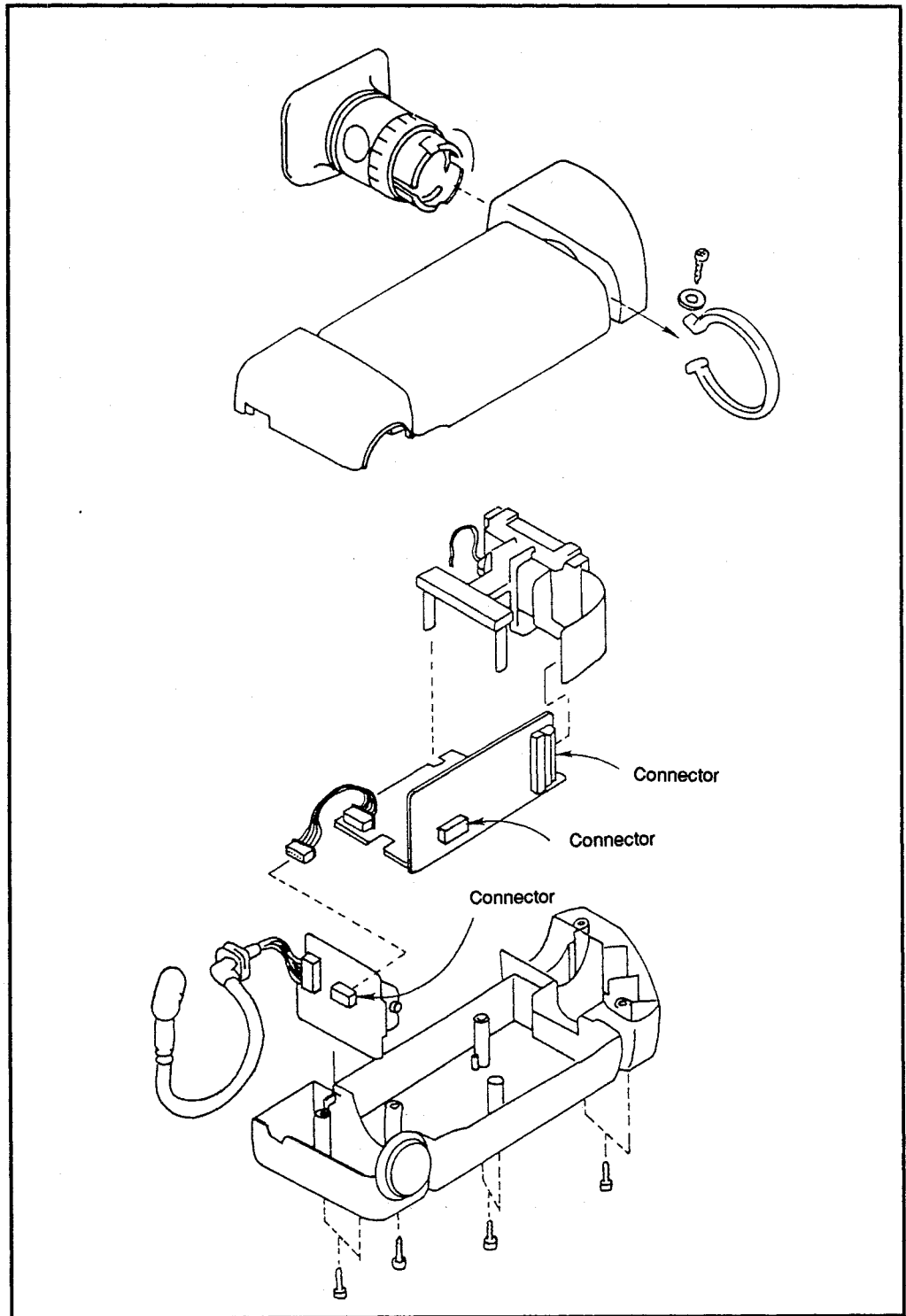


Figure 4: General disassembly of the viewfinder



5/Cam - VCS

Various Case Studies

5/Cam - VCS - Sha-VL-L285U

Sharp VL-L285U

**Eyepiece**

The eyepiece detaches by twisting it counterclockwise. Once this is done you can remove the screw from the cabinet holding bracket. (Be careful to not lose the small washer.) Press down on the lower part of the bracket and slide the bracket off the cabinet. When replacing this bracket in reassembly, use a torque screwdriver and tighten the screw to  $1.1 \pm 0.2$  kg/cm.

**Housing**

The upper and lower parts of the housing are held together with seven screws in the bottom. There are two each at the rear, middle and front, with a single screw near the front. Carefully separate the two halves. Do not force a separation. And, when pulling the two halves apart do so close to a working surface.)

**Main Lower Board**

The main lower board assembly is held in place by a hook. Unplug the connector from this section to the section at the front of the assembly. Carefully unhook the assembly and lift it (GENTLY!) from the cabinet.

The front section is held in place by a single screw that passes through the section and into the cabinet. Remove this screw. Carefully pull upward in an arc at the outer top edge. The section should lift out easily.

The LCD module assembly can be separated from the main PWB, but this should be done only if absolutely essential. Once again it is critical that you proceed cautiously! It's too easy to damage the module, even while it is still in its holder. If you absolutely must touch the module, be sure to ground yourself to eliminate any static charge. Touch the module as little as possible, and then only by the top and bottom edges. DO NOT touch the bonded connectors or the flat cable terminals.

Disconnect the flat cable from the main PWB. Unsolder the lead of the backlight fluorescent tube. Great care is needed. Both heat and pressure can cause the glass of the fluorescent tube to crack. The best you can expect if this happens will be degraded performance. Carefully push the two holding clips sideways and lift out the LCD module, holding it by the upper and lower edges.

In reassembly be sure to carefully align the flat cable between the marks on the holder cover.

**Deflection Plates**

The deflection plates shown in Figure 6 have protective covers on them. If you need to peel these back, be very careful that they do not touch the terminal leads on the flat cable.

The plates are easily scratched. Cleaning them should be avoided. If absolutely

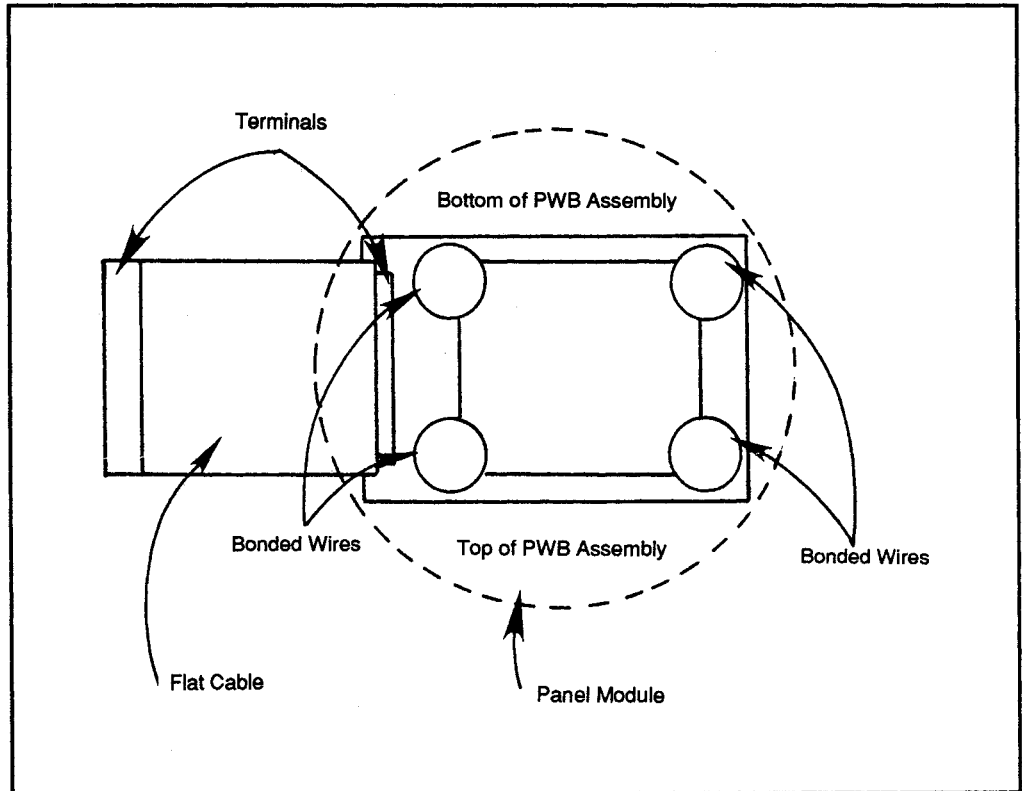


Figure 5: LCD module

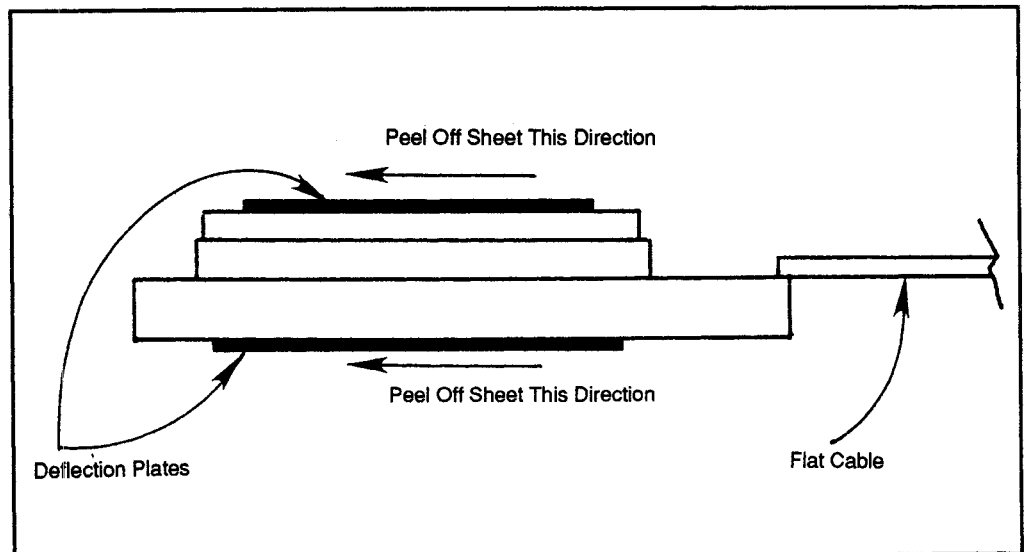


Figure 6: Side view of LCD module

# 5/Cam Camcorder

5/Cam - VCS

Various Case Studies

5/Cam - VCS - Sha-VL-L285U

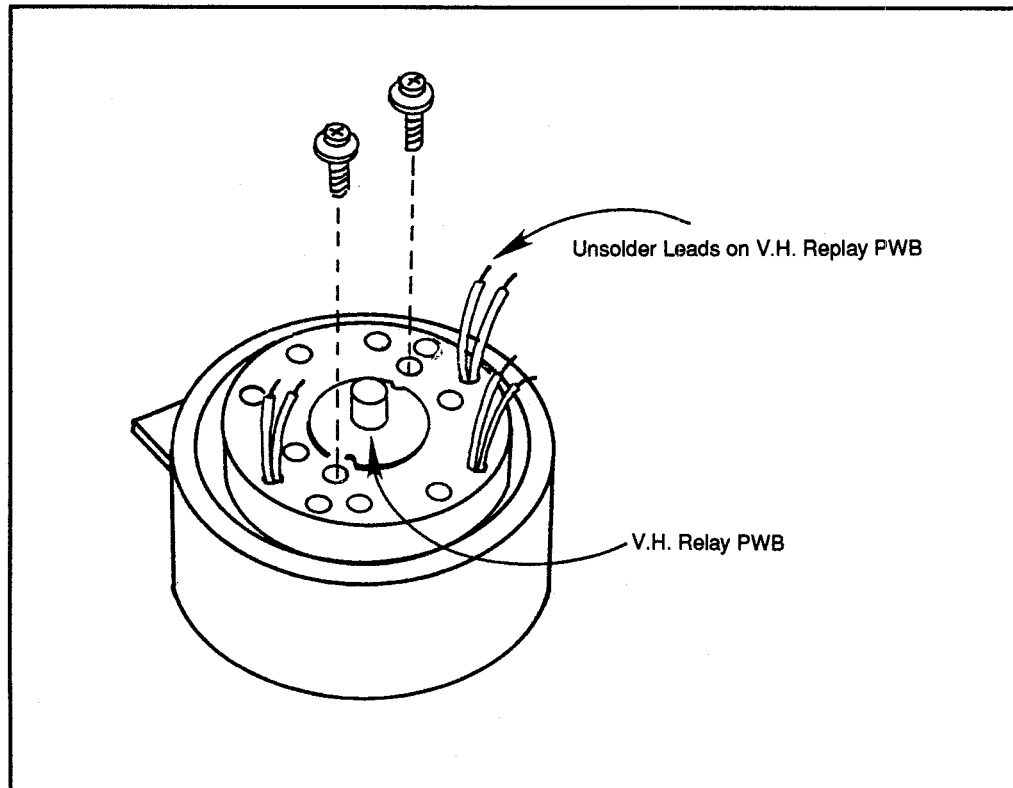
Sharp VL-L285U

necessary, first try cleaning the plates by blowing them with clean, dry air (such as from a can of compressed air). In serious cases, the plates can be cleaned (GENTLY!) with a swab moistened with pure, technical grade ethyl alcohol. It should be noted, however, that if the deflection plates are dirty enough to require this kind of cleaning, the camera is probably being used under adverse conditions. Other problems in the camcorder can be expected. (The heads on the video head assembly, for example, and the various mechanisms, are much more exposed to environmental conditions than the deflection plates.)

## Video Drum Replacement

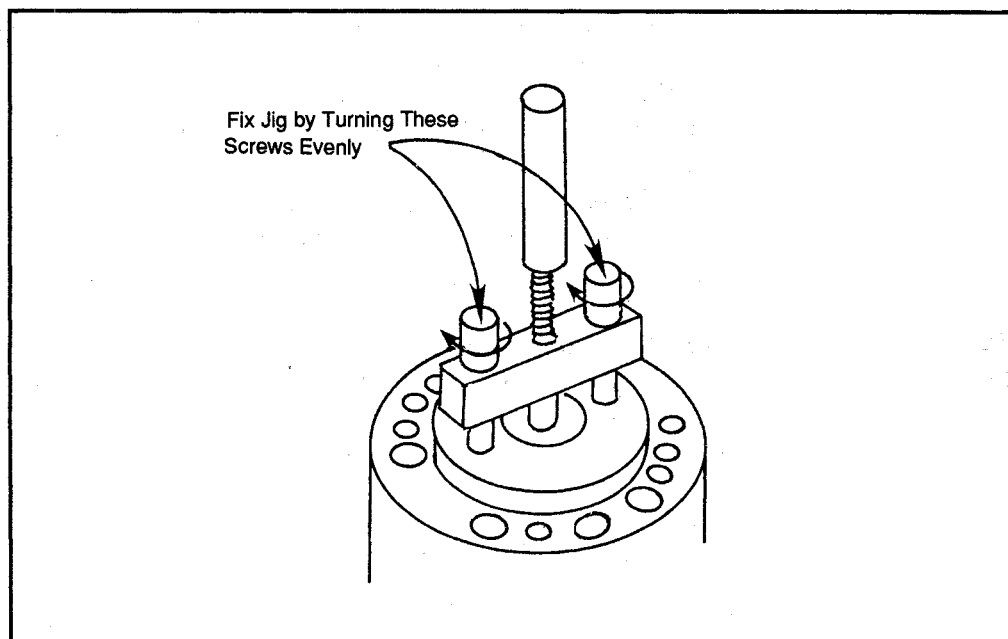
The video head assembly drum is fitted to an extremely tight tolerance. Replacement of the drum should be considered as a last resort and approached with the utmost attention to detail. Small amounts of dust or even scratches on the parts can make proper alignment impossible.

Take precautions so that your fingers never touch the surface of the drum. It is suggested that you use lint-free cotton gloves, such as those found in photographic stores for handling negatives, whenever handling the drum.



**Figure 7:** Desolder leads and remove screws



**Figure 8:** Extracting jig

To remove the old drum, begin by desoldering the leads. Also remove the two screws located near the center of the drum.

**Extracting Jig**

An extracting jig is needed to separate the drum parts. It's critical that the jig be fitted so that the screws are perfectly even. Turn them simultaneously and at the same rate until the jig is fixed into place. Failure to do so can cause the extraction driver to pull the drum at an angle.

When installing the new drum all the precautions become even more critical. The new drum must never be touched with your fingers and must go on evenly. Turn the screws at the same rate to fix the jig. Take your time and be sure that the new drum goes on evenly and smoothly. Resolder the connections and install the two screws.

With the new drum in place, go through all the steps given above concerning mechanical adjustments, paying special attention to checking the tape travel path.

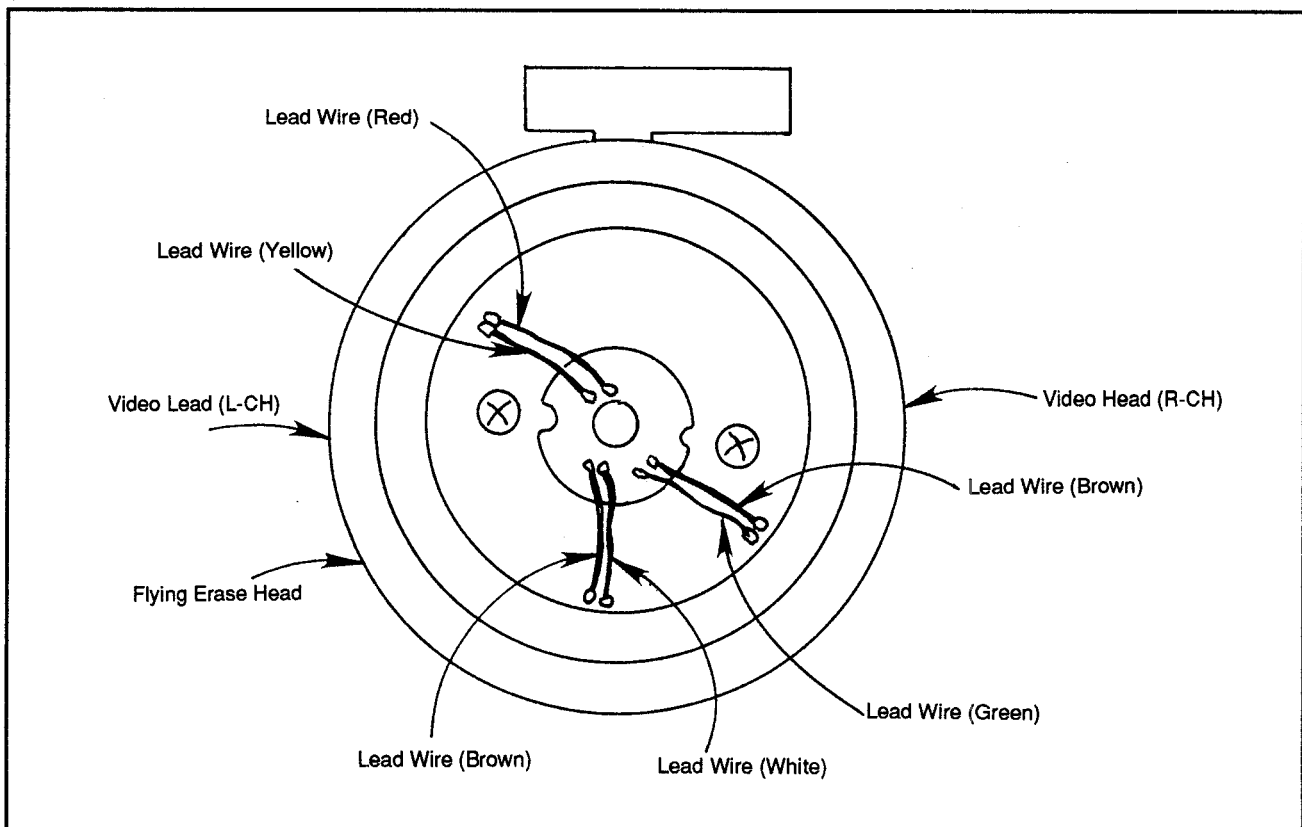
**Camera  
Adjustment**

To make camera adjustments you need some special extension cords. These are listed in the following table. You also need JIGSTAND L170. This hooks to a tripod, with the lens attaching to the jig by a groove.

**Extension Cords**

Cord	For
QCNW-0992TAZZ	PA ↔ AN
QCNW-0993TAZZ	SA ↔ AM
QCNW-0994TAZZ	PB ↔ AP
QCNW-0997TAZZ	PG ↔ SD
QCNW-0996TAZZ	PD ↔ SD

Disassembly is rarely needed for most of the tests and adjustments given in this section. It should be done only if you have a reason to get inside the camera. Before you remove the camera from the camcorder, try to be sure first that the problem is in the camera and requires its removal.

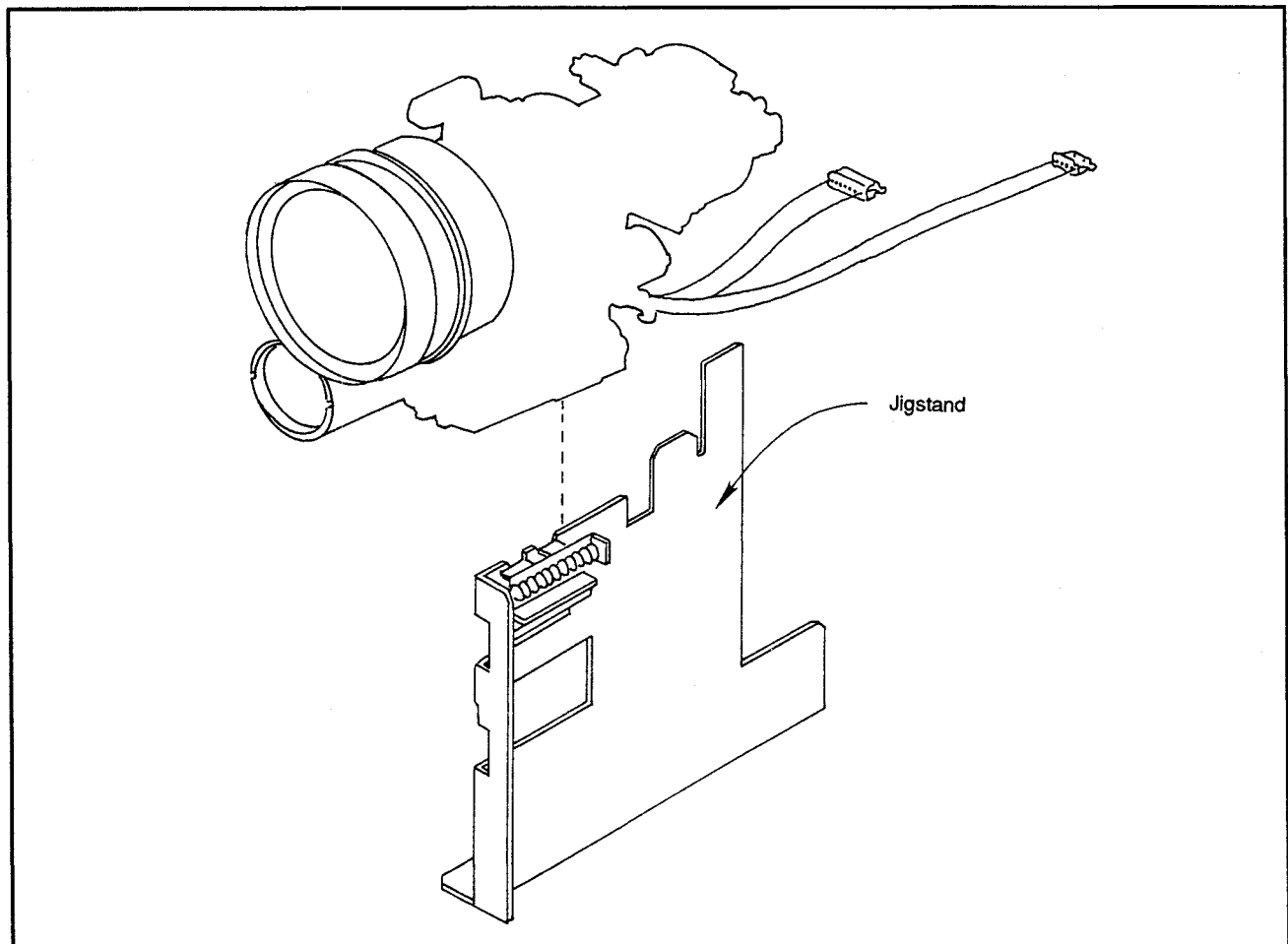


**Figure 9:** Installation guide for new drum

**CCD Sensor**

Care must be taken when performing any disassembly of the camera, particularly if you are working with or around the CCD sensor. This device is highly sensitive to static electricity. It's important that you wear a wrist strap to drain off any possible static charge in your body. Sharp suggests using a 1 M $\Omega$  resistor between yourself and ground. Also, any soldering iron used **MUST** be of the grounded type with anti-static protection. Finally, when the CCD is out of its PWB, the CCD should have its pins inserted into a conductive pad or sponge. This causes the pins to short and helps to protect the device.

The CCD may also be damaged physically. It is extremely sensitive. Put on the wrist strap to ground yourself. If you must desolder the CCD, use **ONLY** a grounded soldering tool that also has anti-static protection, and even then use as little heat as possible. Once you've unsoldered the CCD, remove it from the board, and immediately place it in the conductive pad.

**Figure 10: Jigstand and lens**

# 5/Cam

Camcorder

5/Cam - VCS

Various Case Studies

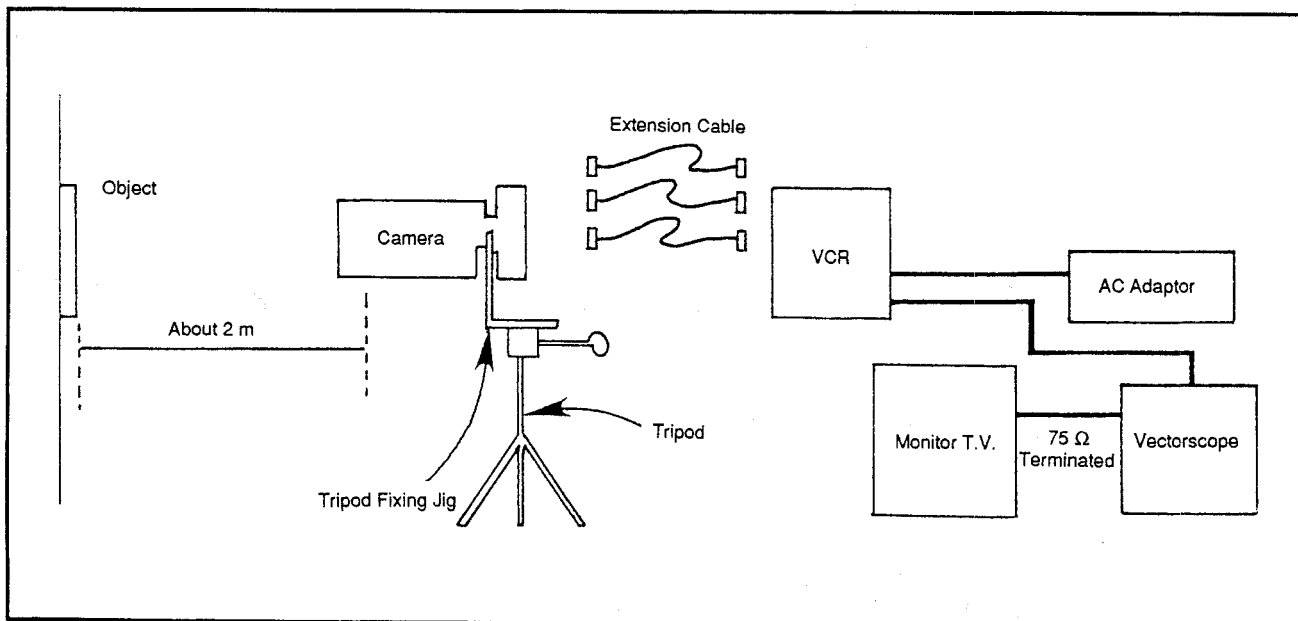
5/Cam - VCS - Sha-VL-L285U

Sharp VL-L285U

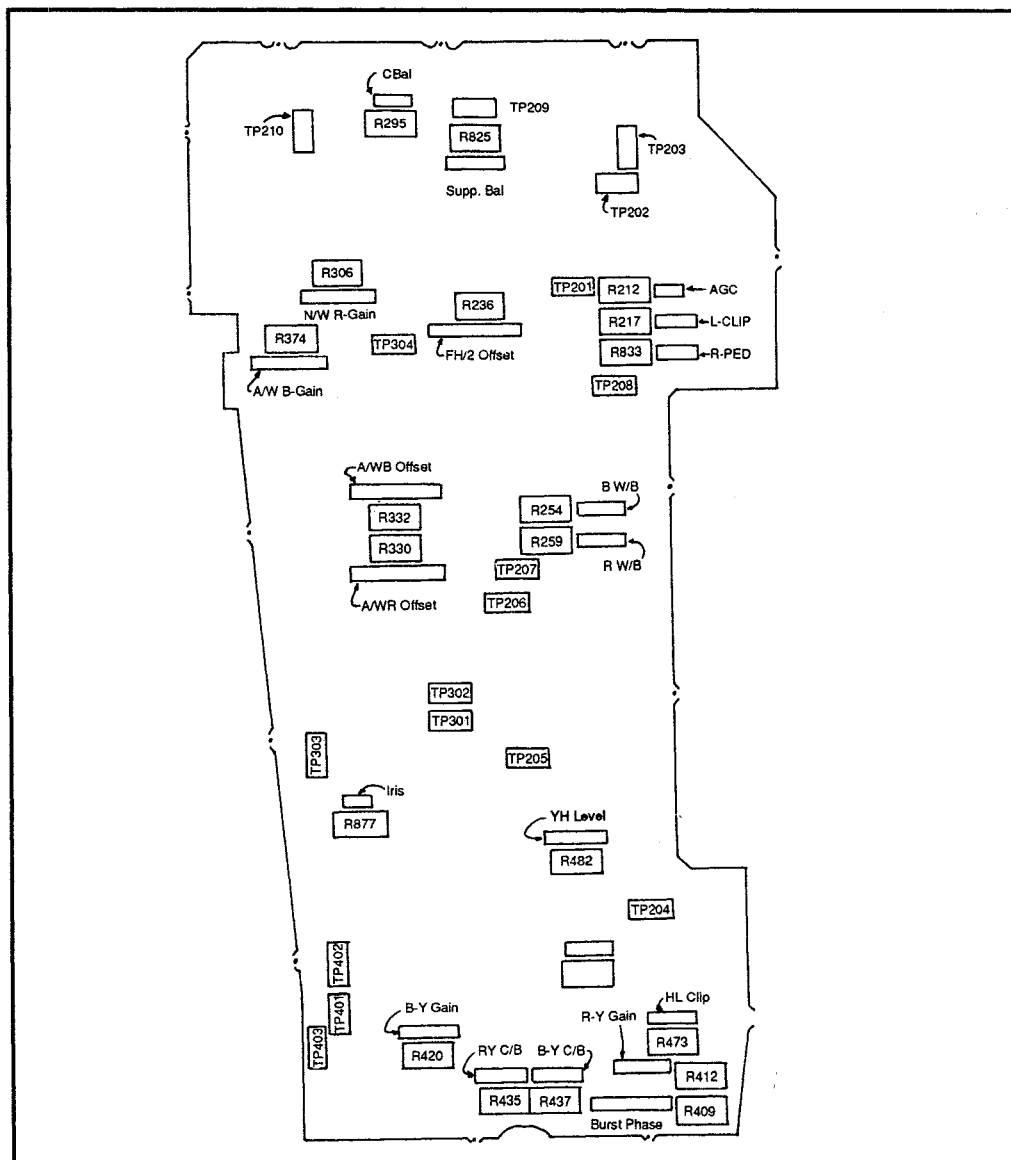
The surface of the CCD is easily scratched. Even something as simple as a fingerprint can seriously degrade operation. If the surface must be cleaned, use silicon paper or chamois designed for use on fine optics. Set up the camera as shown in Figure 11. To make the tests you will need the tools and test equipment listed below.

## Tools and Test Equipment

Gray scale  
 Color bar pattern chart  
 White pattern  
 Siemens star  
 Color temperature conversion filter (Hoya LB165 or Fuji MG-5)  
 Frequency counter  
 Oscilloscope  
 DMM  
 Vectorscope  
 Illuminometer  
 Color video monitor  
 Two halogen lights  
 Extension cables  
 AV output cable  
 12 VDC power supply  
 Lens tracking driver



**Figure 11:** Set up for testing and adjusting



**Figure 12:** Location of test points and controls on encorder board

To set up, aim both lights so that the pattern is evenly lighted to a brightness of about 3000 lux. The preferred color temperature should be 3200 °K.

The order of tests is as follows:

*Check power supply*

Tested at P502 on the SSG board.

$20\text{ V} \pm 1\text{ V}$   
 $9.4\text{ V} \pm 0.4\text{ V}$   
 $-11\text{ V} \pm 1\text{ V}$   
 $5\text{ V} \pm 0.05\text{ V}$   
 $12\text{ V} \pm 0.5\text{ V}$

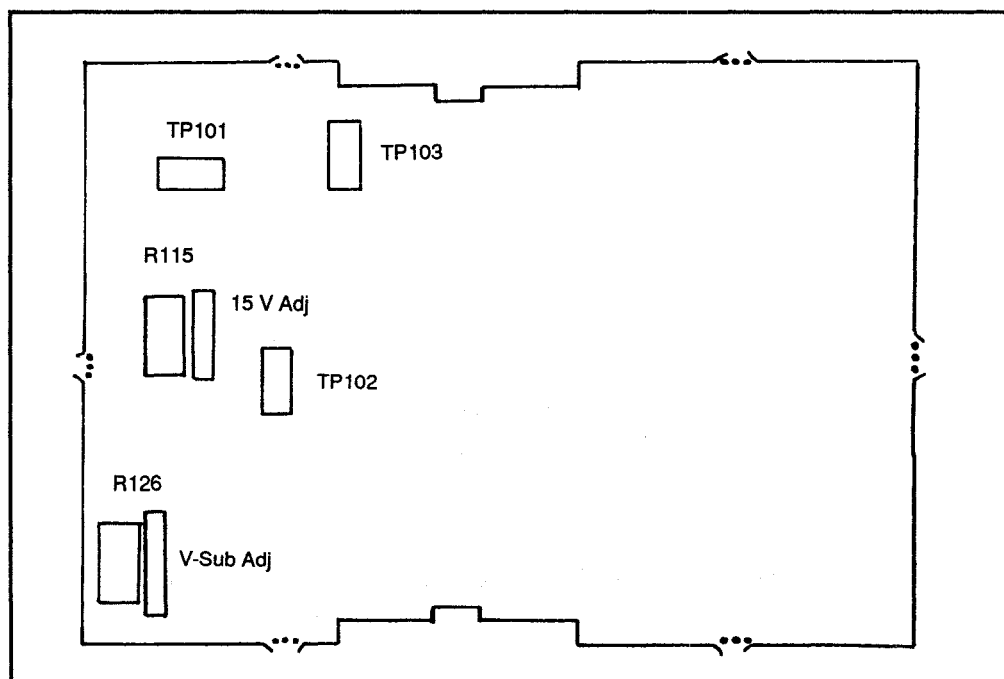
*+15 volt adjust*

At TP101, adjusted at R115; adjust R115 so the DMM reads  $15\text{ V} \pm 0.05\text{ V}$ .

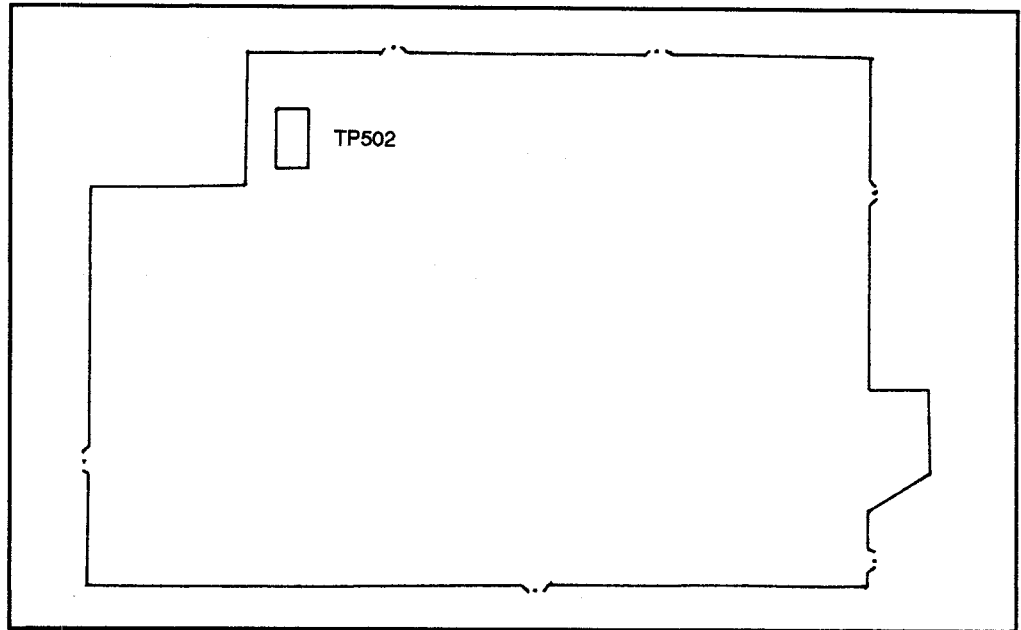
*V-sub voltage adjust*

At TP102, adjusted at R126; adjust until the voltage is as marked on the back of the CCD sensor. The coding consists of two digits or a letter and a digit. The first signifies the integral figure; the second the decimal figure. For example, if the code is c5, the correct voltage would be 12.5.

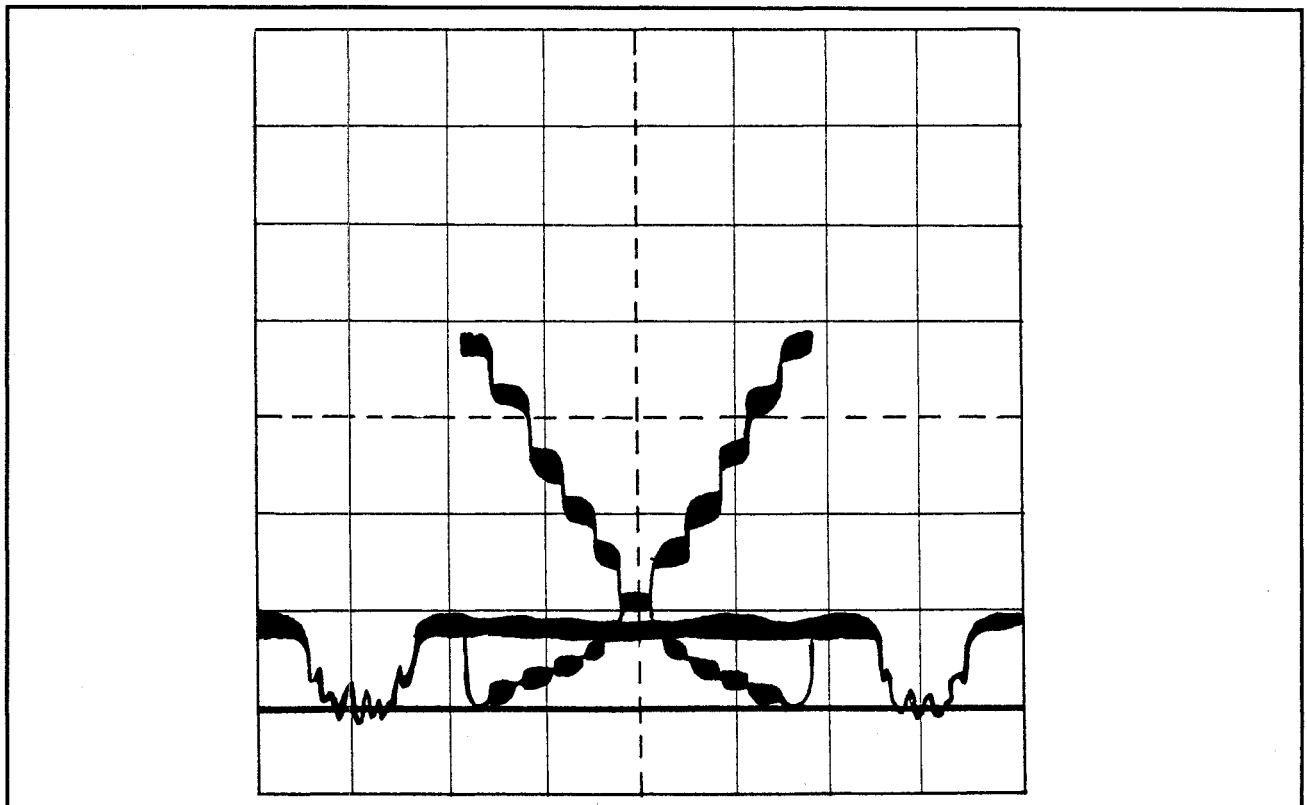
Code	7	8	9	a	b	c	d	e	f	g	h	i	j
Volts	7	8	9	10	11	12	13	14	15	16	17	18	19



**Figure 13:** Location of test points and controls on sensor circuit board



**Figure 14:** Location of test point on SSG circuit board



**Figure 15:** Iris adjust waveform

*Iris adjust*

Short circuit between TP303 and TP301; short circuit between TP303 and 302; connect oscilloscope to TP201; while camera is aimed at gray scale, adjust R877 to an amplitude of 380 mVp-p.

*L-clip adjust*

Connect oscilloscope to TP205; with lenscap in place, adjust R217 until scan and blanking periods coincide.

*AGC amplitude adjust*

Connect oscilloscope to TP205; with camera aimed at gray scale, adjust R212 for an amplitude of 450 mVp-p.

*C-balance adjust*

Connect oscilloscope to both TP202 and TP209; adjust R295 so that both signals are identical.

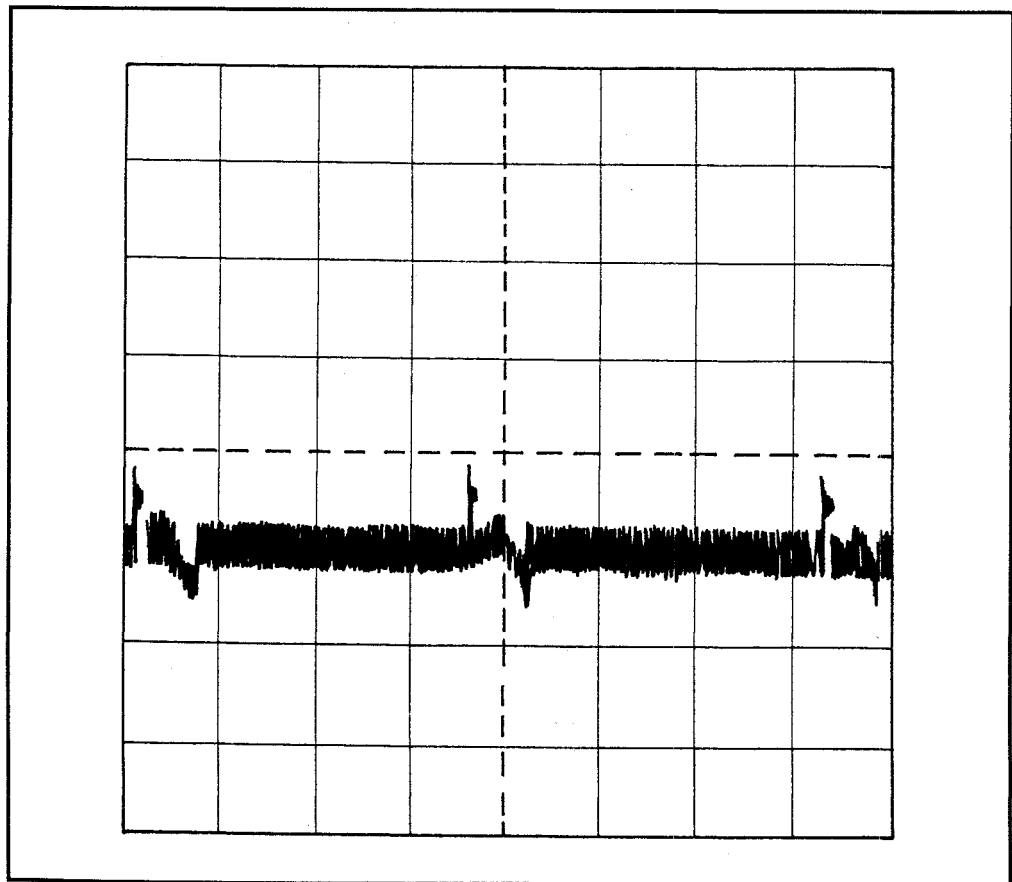
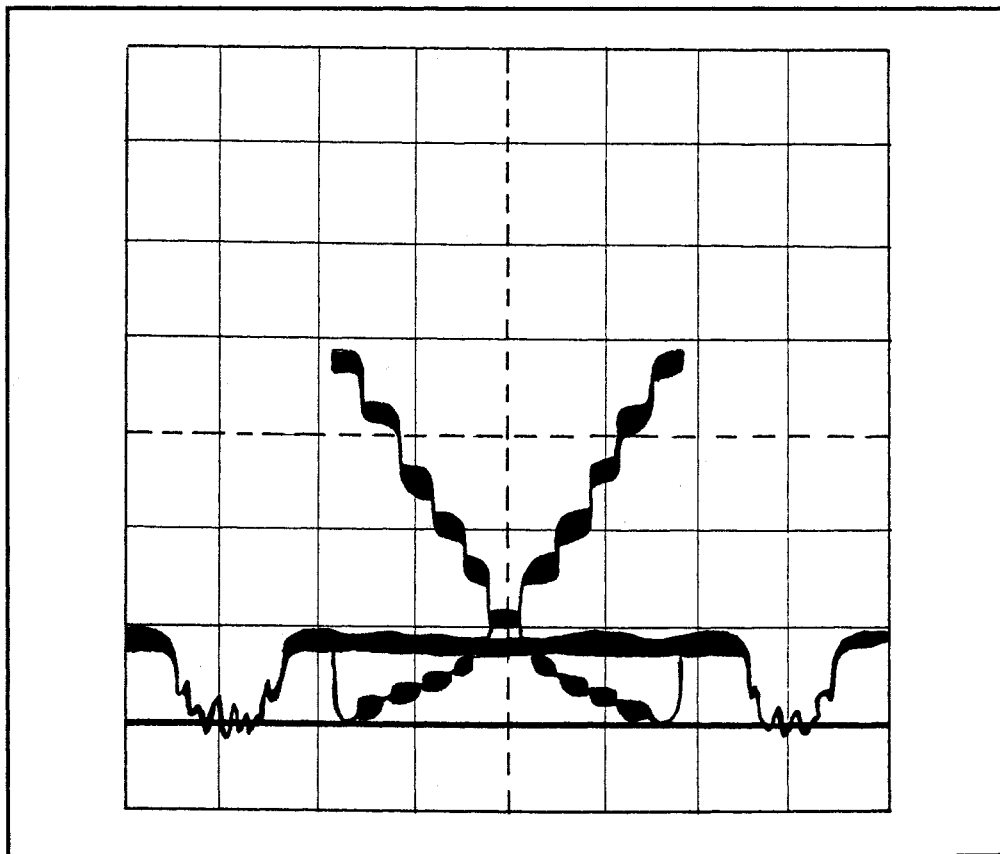


Figure 16: Clip adjustment





**Figure 17:** AGC amplitude adjust

*Suppress-balance adjust*

Connect oscilloscope to TP203; with camera aimed at color bar pattern, adjust R825 to minimize signal leakage.

*FH/2 offset R-PED adjust*

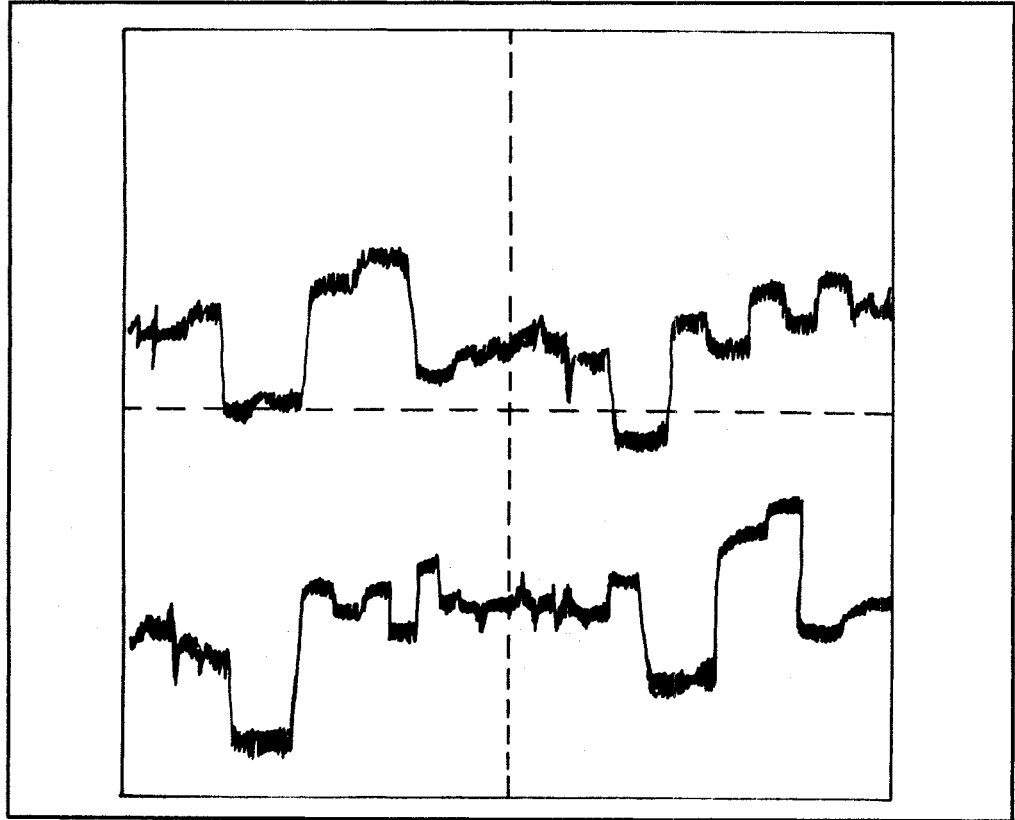
Connect oscilloscope in X-Y mode to both TP206 and TP207. With the lens capped adjust R236 and R833 so that the dispersion of bright points vanishes.

*White balance adjust*

Connect oscilloscope to both TP206 and TP207. With camera aimed at gray scale, adjust R259 and R254 to minimize signal leakage.

*VE-balance adjust*

Connect oscilloscope to TP204; with camera aimed at gray scale, adjust R850 to minimize signal leakage.



**Figure 18:** C-balance adjust

*YH adjust*

Connect oscilloscope to TP402; adjust R482 until signal is 700 mVp-p.

*R-Y C/B, B-Y C/B adjust*

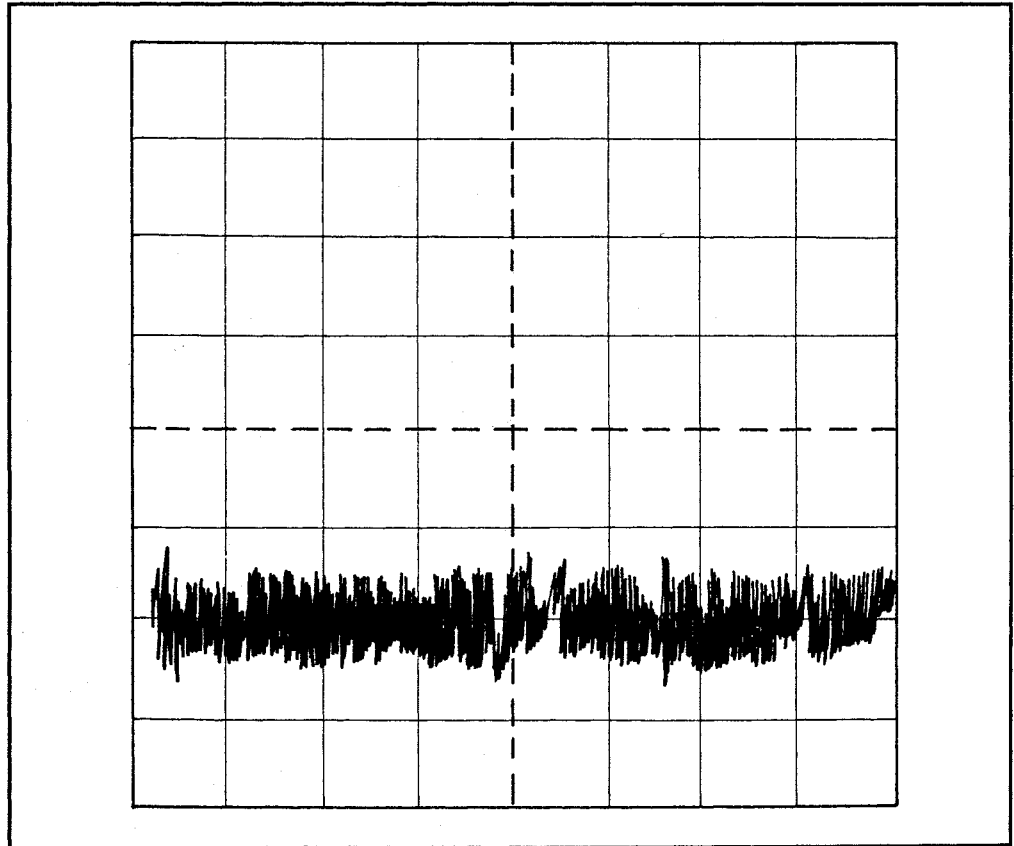
Connect vectorscope to EE out; with lens capped, adjust R435 and R437 until point of brightness is centered.

*R-Y gain adjust*

Connect oscilloscope to TP401; with camera aimed at color bar pattern, adjust R412 until red signal becomes 2.1 times the burst level.

*B-Y gain adjust*

Connect oscilloscope to TP401; with camera aimed at color bar pattern, adjust R420 until blue signal is 1.8 times the burst level. The image should look like Figure 22.



**Figure 19:** Suppress-balance adjust

*Burst phase adjust*

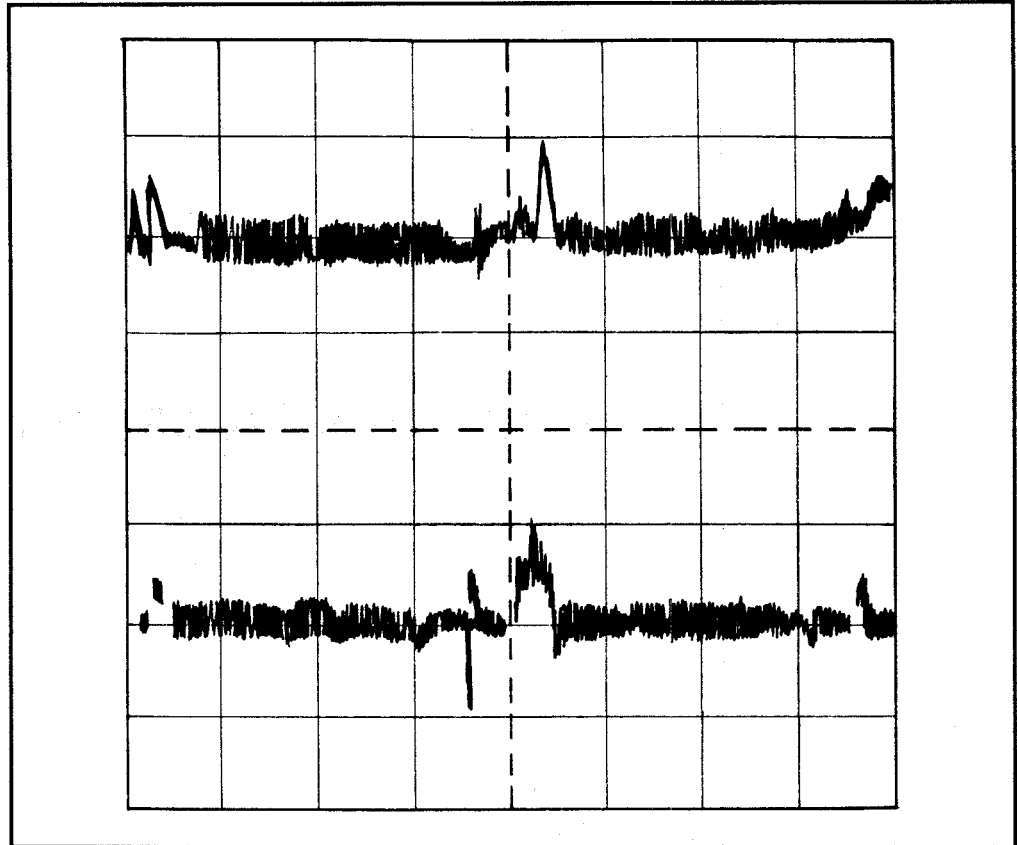
Connect vectorscope to EE out; adjust R409 until red brightness point phase is 103°.

*Auto white balance adjust*

Short between TP301 and TP303; short between TP302 and TP303; connect oscilloscope to TP304; adjust R332 until signal level is 50 mV below the BL portion level.

Break the short between TP301 and TP303; connect vectorscope to EE out; adjust R254 to bring bright spot to the coordinate origin.

Break the short between TP302 and TP303; adjust R330 to bring bright spot to the coordinate origin.



**Figure 20:** White balance adjust

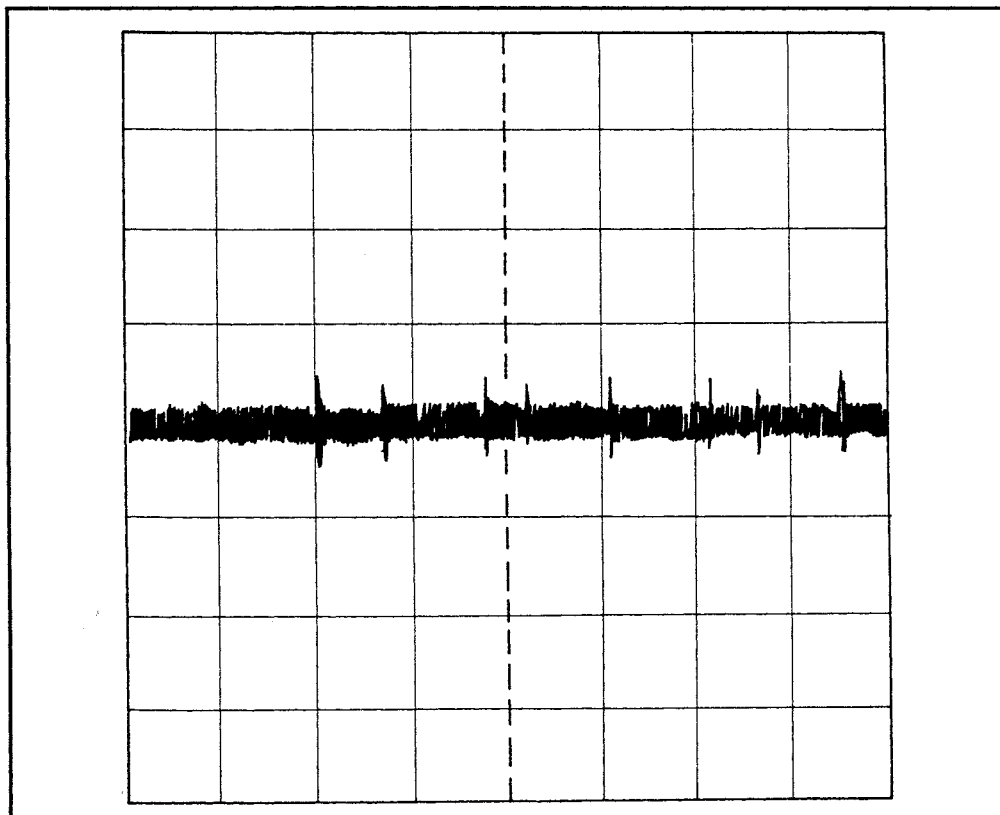
Cover the lens with a color temperature conversion filter; adjust R306 and R374 so the bright spot coincides with coordinate origin.

*H.L. clip adjust*

Connect oscilloscope to EE out; with camera aimed at gray scale and lens covered with W12 temperature conversion filter, press and hold backlight compensation switch; adjust R473 so that the ninth white carrier level becomes 230 mVp-p.

*Auto focus adjust*

Set A/F adjustment chart 200 cm from lens and its perfect square; if camcorder is assembled, remove the three holding screws and remove front cover; place lens in full TELE position and center chart; if deviation is not from 1.1 mm to infinity, loosen autofocus retaining screw with 1.5 mm hex wrench and turn adjusting screw with tracking driver.



**Figure 21:** VE-balance adjust

### Adjustment of LCD Viewfinder

It's important to remind you again of the delicacy of the devices used inside the viewfinder. Great care must be taken and disassembly should be kept to a minimum. Be sure to wear a grounding strap to avoid any static buildup from damaging the LCD and its related parts.

Testing the viewfinder circuit can be divided into 6 general parts, as detailed below. For each, connect the A/V output of the camcorder to a video monitor. The tint, color, contrast and other controls on the monitor should be placed in the standard setting with good color and depth. Adjust R728 and R731 until the image in the viewfinder is similar to that on the monitor.

For the input signals, use a 1 V<sub>p-p</sub> signal, terminated with 75 Ω.

#### *+11 V adjustment*

With camera in STOP, connect DMM to TP707; adjust R789 until reading is 11 V ± 0.04 V.

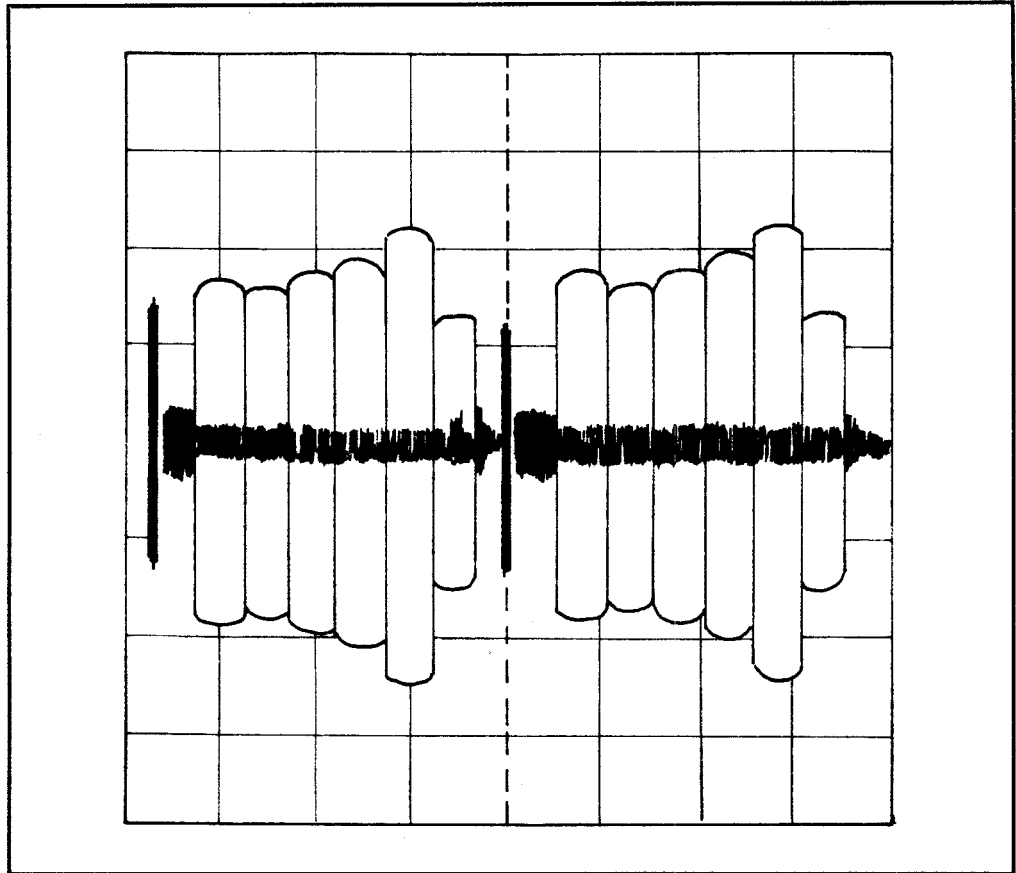


Figure 22: R-Y Gain adjust & B-Y gain adjust

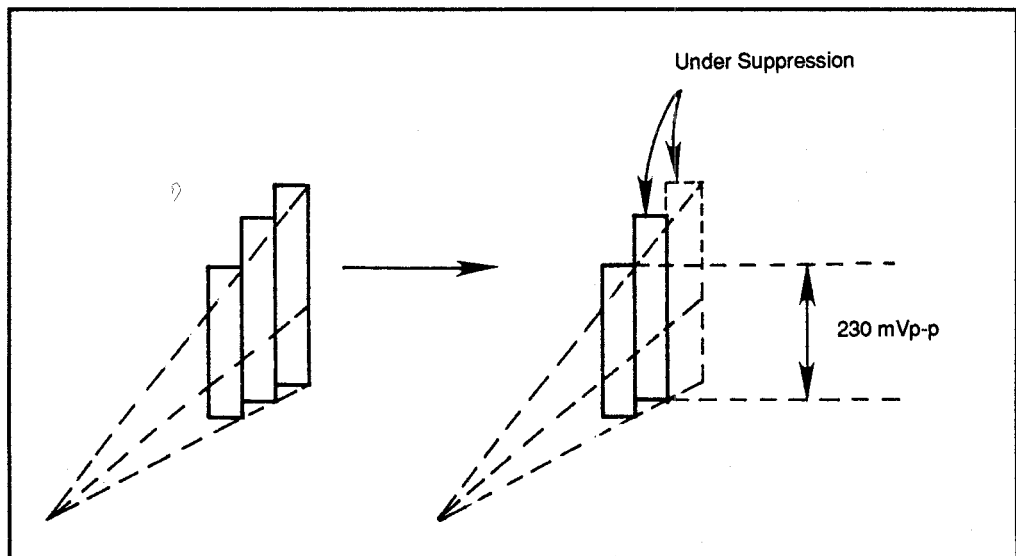
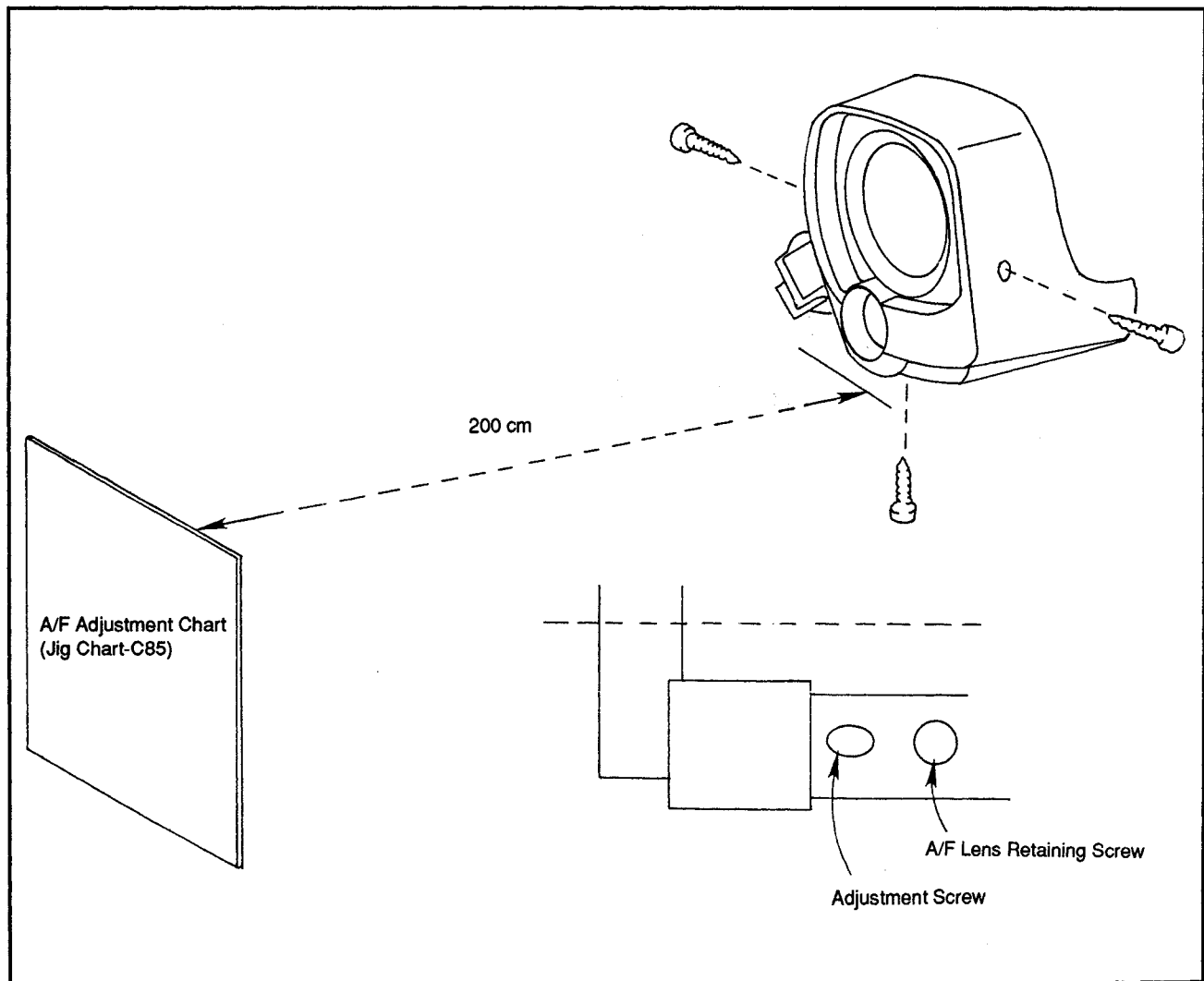


Figure 23: H.L. clip adjust



**Figure 24:** Auto focus adjust

*Low frequency AFC*

Connect oscilloscope to TP701 (trigger) and TP702, and oscilloscope ground connected to TP706; with signal injected, adjust R766 until phase error is  $2.2 \pm 0.2 \mu\text{s}$ .

*High frequency AFC adjustment*

Connect oscilloscope to TP701 (trigger) and TP703, and oscilloscope ground to TP706; with signal injected, adjust R769 until the phase error at TP703 is  $0.1 \mu\text{s}$  or better.

*Contrast gain adjustment*

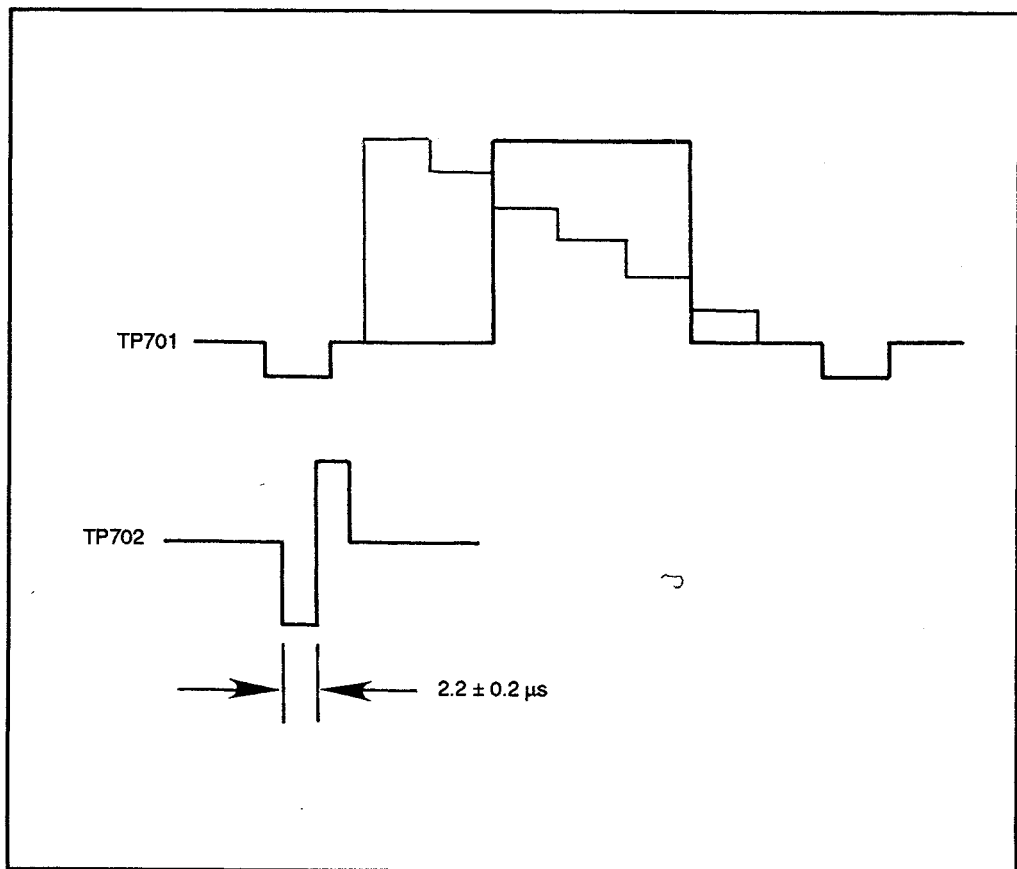
Connect oscilloscope to TP701(trigger) and TP705, and oscilloscope ground to TP706; with signal injected, adjust R720 until the signal voltage at TP705 between pedestal and white peak is  $1.1 \text{ V} \pm 0.06 \text{ V}$ .

*Brightness level adjustment*

Set R702 (user control) to center position; with a gray scale inject at EE, adjust R775 to the point that the signal is slightly to the white side of red purple.

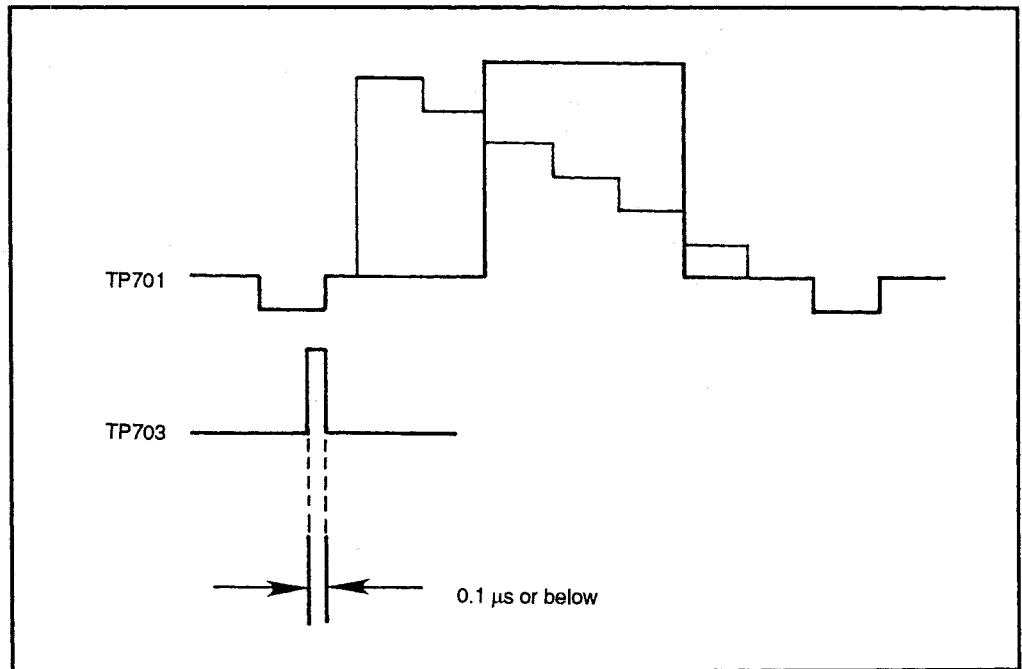
*White balance adjustment*

With signal injected, adjust R738 (green) and R746 (blue) until each gradation has less color.



**Figure 25:** Waveforms for low frequency adjustment





**Figure 26:** Waveform for high frequency adjustment



---

5/Cam - VCS

Various Case Studies

---

5/Cam - VCS - Sha-VL-L285U

Sharp VL-L285U

---

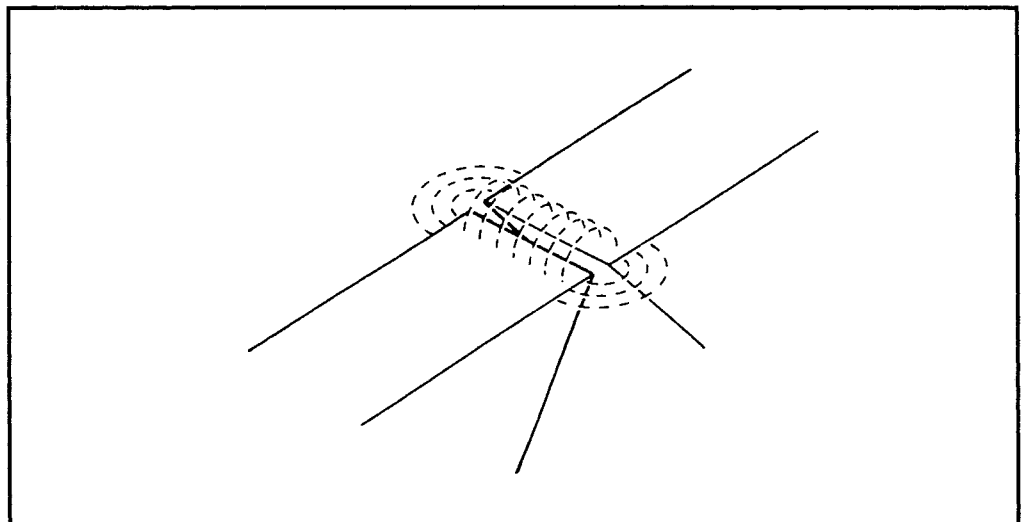
## 5/VCR - A

### An Introduction

## 5/VCR - A - VHS

### VHS Standard

A video cassette recorder (VCR) records and plays video and audio signals by using a magnetic medium. The original concept began in the 1940s. The first VCR was developed in 1956 by Ampex. This used a cumbersome and expensive 2-inch video tape taken from a large supply reel. The tape was pulled at high speed across a quadruplex video head and wound onto a large takeup reel. The invention was remarkable at the time but cannot compare with what followed. In this article we will discuss the VHS 1/2 inch video recorder.

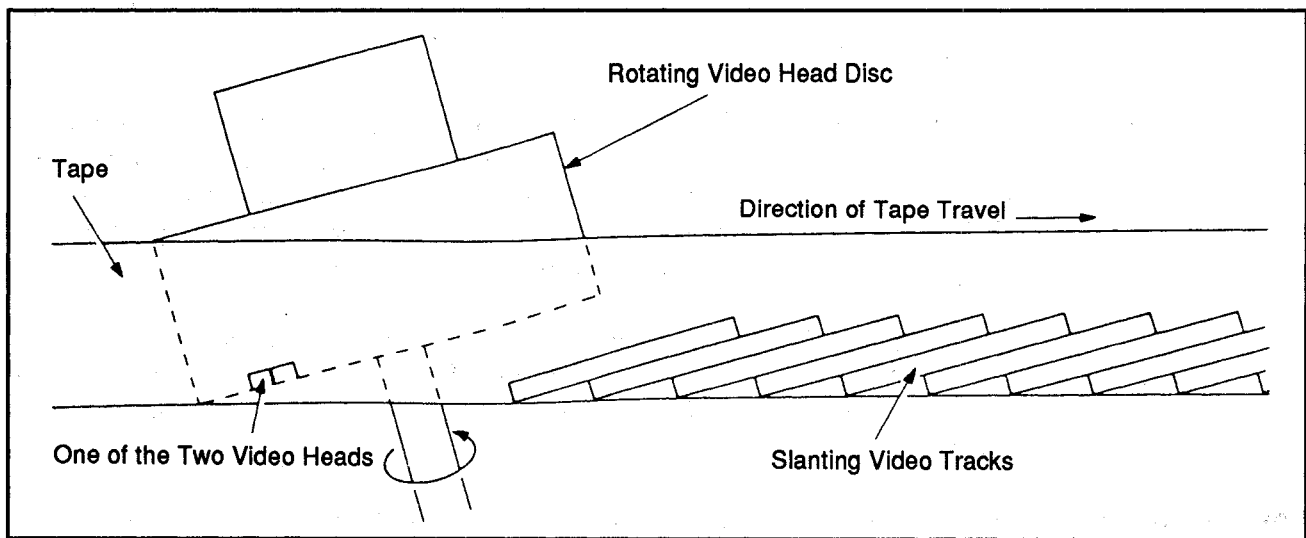


**Figure 1:** How an electromagnetic head generates a magnetic flux.

The standard T-120 cassette holds 246 meters of 1/2" tape, providing up to 6 hours of recording/playback. Video information is stored on magnetic tape by means of small electromagnetic heads. The head generates a magnetic flux across the pole gap as shown in Figure 1. Because of the way the tape moves across the head assembly, the information is recorded on in a helical pattern as shown in Figure 2. The effective length of the tape is greatly increased. With the tape moving forward and the head assembly spinning at a high rate, the effective tape speed is also increased. The combination is what allows the VCR to hold up to 6 hours of recording (as compared

to the original design which required huge reels of tape for just a few minutes of poor quality—by modern standards—recording).

The videotape is wrapped around the drum assembly in a horseshoe shape. The video heads are placed 180° from each other and rotate at 1800 rpm. The drum assembly is tilted so the video heads pass in a slanted pattern across the video tape. Each head completes one rotation in 1/30th of a second, and each slant track is recorded during half of a complete rotation of 1/60th of a second.



**Figure 2:** The helical pattern causes the video to be recorded in "stripes."

The drum head is controlled by a single direct drive (DD) motor which rotates the video heads. The capstan is controlled by a separate DD motor which pulls the tape through the VCR. To maintain proper control so the tracks are accurately traced by the rotating heads, an automatic self-governing arrangement called the servo system is used. Servo systems are discussed in "5/VCR - T - CSP".

The modern VCR uses a 2/4 head configuration or a 3/5 head configuration. Two or three heads are all that are required and used to record video images on videotape. The additional two heads are used for special functions like slow motion, pause, still frame, and scanning.

In Hi-Fi models two heads are added to the drum assembly. The audio track is then recorded with the video portion of the tape and in the same helical pattern. As above, the effective increase in relative speed allows for good high-fidelity. Standard audio (monaural) is recording on a linear track at the top of the tape by a stationary audio/control head located on the exiting side of the videotape stream.

---

## 5/VCR - M

### Maintenance

---

#### Cleaning

General maintenance should include little more than cleaning inside and outside of the VCR. In some cases, simple testing, and possibly checking the unit for proper alignment, may be needed.

**External Cleaning** External cleaning can be done with your normal house cleaning. This is nothing more than dusting the casing with a moistened cloth once a week. Environmental elements (smoke, dust, moisture, people, pets, etc.) produce airborne particles that can become deposited on the surface of a VCR. Some of these particles will work their way within the unit and will need to be removed as well.

Vents on the VCR must be kept clear of items that may block proper air flow. Placing items on top of the VCR, or the use of a cover will constrict air flow. Dust covers should be removed when operating VCRs. These vents should be wiped clean during the periodic cleaning period.

**Internal Cleaning** Internal cleaning for VCRs and camcorders consists of cleaning the tape path and blowing dust from the inside of the unit.

Blowing the deposited dust particles from a VCR is best done before cleaning the tape path. Compressed air works well. The pressure should not be so high as to blow parts from the unit. Clean the unit in an environment where you will not be contaminating other pieces of equipment.

Check with the service manual for the specific unit being serviced as to what can and cannot be done to the different parts. For example, a motor with sealed bearings will not accept lubrication. Any oil applied can then end up in places that will be damaged, such as video heads.

Oxide builds up on the video heads as a tape is played. The video heads penetrate into the tape oxide when the unit is playing and recording. When the spacing of a video head and a videotape is 1/20,000 of an inch (0.00020"), any buildup of oxide can cause problems.

Cleaning the VCR's audio, tracking, erase and video heads is best done with



cleaning fluid (Freon, if available). The use of technical grade isopropyl (96% pure or better) or completely denatured alcohol are also effective. The use of ethyl alcohol is not recommended since this may leave a residue. NEVER use standard rubbing alcohol. It contains water, oils and various other substances which can cause considerable damage.

You will also need a good quality chamois (such as optical grade) or foam swabs. Never use cotton swabs for cleaning the video heads as cotton strands will catch on the edges of the video heads. Bits of ferrite might be pulled from the mounting, destroying the heads.

The use of commercial cleaning tapes is not recommended. They tend to be abrasive. Some leave deposits and residues behind, actually causing the VCR to become more dirty. These cleaning tapes should be used as a last resort.

The video heads (and the machine in general) should be cleaned after every 100 hours of use, or 3 times per year. If you are playing a number of rental tapes, cleaning will probably be necessary more often. Rental tapes are played in other VCRs, which may have never been cleaned.

The heads may also have to be demagnetized. The problem with this is in finding a demagnetizer suitable for the delicate video heads. Those used to demagnetize audio heads are often too powerful. They can cause damage to video heads, and may even cause the video head to vibrate to such an extent that it shatters.

### **Cleaning Procedure**

Unplug the VCR and remove the cover. Each VCR will differ slightly, but the screws for removing the cover will usually appear similar to Figure 1. Also, the cover will probably have a lip at the front which slides beneath the front panel. With the screws removed, lift upward from the back of the cover. If it doesn't come off readily, look for other screws or catches which are holding it. (A few VCRs actually have a holding screw for the top cover located beneath the machine.)

On top loading machines you may have to remove the tape loading mechanism cover to remove the VCR cover.

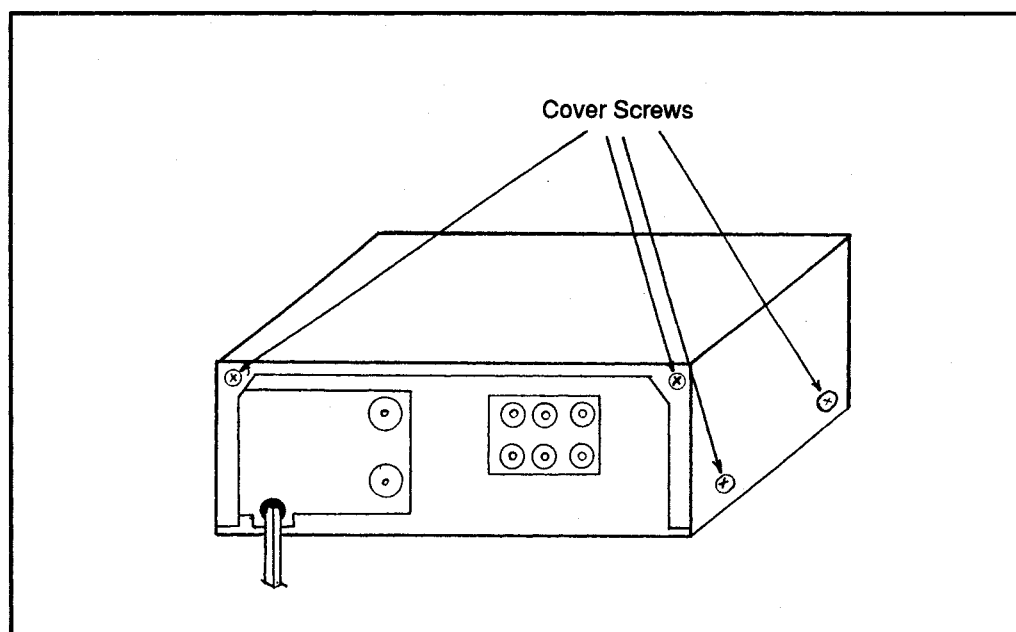
Inside there may be a circuit board above the video drum and tape path. Usually there will be a release mechanism allowing the board to swing back or up out of the way to give access. There may also be two or more holding screws through this circuit board.

Once the cover is off, locate the video drum and identify the various parts of the tape path.

Generously soak the cleaning pad with cleaning fluid and hold the cleaning pad against the side of the video drum. Use very little pressure. Let the cleaning fluid do the work. **DO NOT SCRUB!**

With the wetted pad touching the head assembly, gently rotate it in a complete circle, first in one direction, then the other. Moisten the pad if needed and clean the other heads (audio, tracking, erase). Visually examine the interior and see if other areas need cleaning. The entire job should take only a few minutes.

Wait for a short time to allow the fluid to dry. Plug the VCR in again and see if the audio or video problem has improved. If not, unplug the VCR, wet the pad and try rocking the video drum back and forth against the pad. For the stationary heads, gently rub up and down, then side to side. Test the VCR again. If the problem hasn't been solved, the heads will have to be replaced.



**Figure 1:** Screw positions for VCR cover removal

## Lubrication

The tape transport mechanism is properly lubricated at the factory and additional lubrication should not be required during the first year of operation. Any lubrication will not (usually) be required for the first 1000 hours. Periodic inspection for lubrication will be specified in the machine-specific service manual.

Checking the lubrication during the head cleaning process is, however, a good practice.

When lubricating, remove the old lubricant first. Be careful not to apply too much oil, a drop should do. A squeaky bearing should be lubricated (but not a sealed bearing). Wipe off excess oil with a cleaning stick and alcohol.

Many manufacturers have their own grease and lubricants. Refer to the service manuals for their recommendations. If no recommendations are available, use a high grade oil and/or grease in the unit. Never use WD-40 in electronic equipment.

Places needing lubrication are:

- Loading gears
- Loading gear shaft
- Gutter of chassis
- Gutter of cam gears
- Shaft of loading rings
- Shaft of idler gears
- Ring idler gear
- Between pressure roller bar and shaft
- Between pressure roller and gear assembly
- Between base of guide rollers and gutters



# 5/VCR

Video Recorder

5/VCR - TE

Test Equipment

## 5/VCR - TE

### Test Equipment

Test equipment for work on VCRs can be costly. Most of the equipment you would use for electronic repair of other items will work in VCR repair, but you must also deal and conform to National Television Systems Committee (NTSC) video standards, which require access to specialized video equipment.

The equipment you will need for testing and repairing the VCR will be:

#### Dual-trace Oscilloscope

Having a 30 to 50 MHz bandwidth, and preferably with true TV sync separators built into the trigger circuits for both vertical and horizontal sweep rates.

#### Frequency Counter

Ranging from 1 Hz to 30 Hz and an accuracy of .01 Hz is best.

#### Transistor Checker

An in-circuit unit will greatly simplify checking the multitude of transistors and FETs.

#### Video Analyzer

No VCR repair person should be without a video analyzer. With this, both TV and VCR servicing can be done with one test unit.

#### NTSC Color Bar and Pattern Generator

Generates the required test patterns needed for checking alignment of monitors/TVs.

#### Vectorscope Waveform Monitor

Used for processing the color bar signals for proper chroma and luminance alignment.

#### Test Tapes

Manufacturer supplied test tapes are costly. Using a copy for preliminary testing before inserting your original alignment tape into a video machine is advised. You can create test tapes by using your color bar/pattern generator or video analyzer which will allow you to do preliminary alignments of color circuits and luminance circuits. The test tape will have Bar Sweep, Chroma Bar Sweep, Color Bars, various low/high audio signals, and Cross Hatch patterns in 2 speeds.

#### Video Monitor

The best video monitors have the ability to underscan the picture. Adjusting the vertical and horizontal height of a normal TV set can shrink the image size. If this is possible, the TV set could be used as an underscan monitor. Underscanning

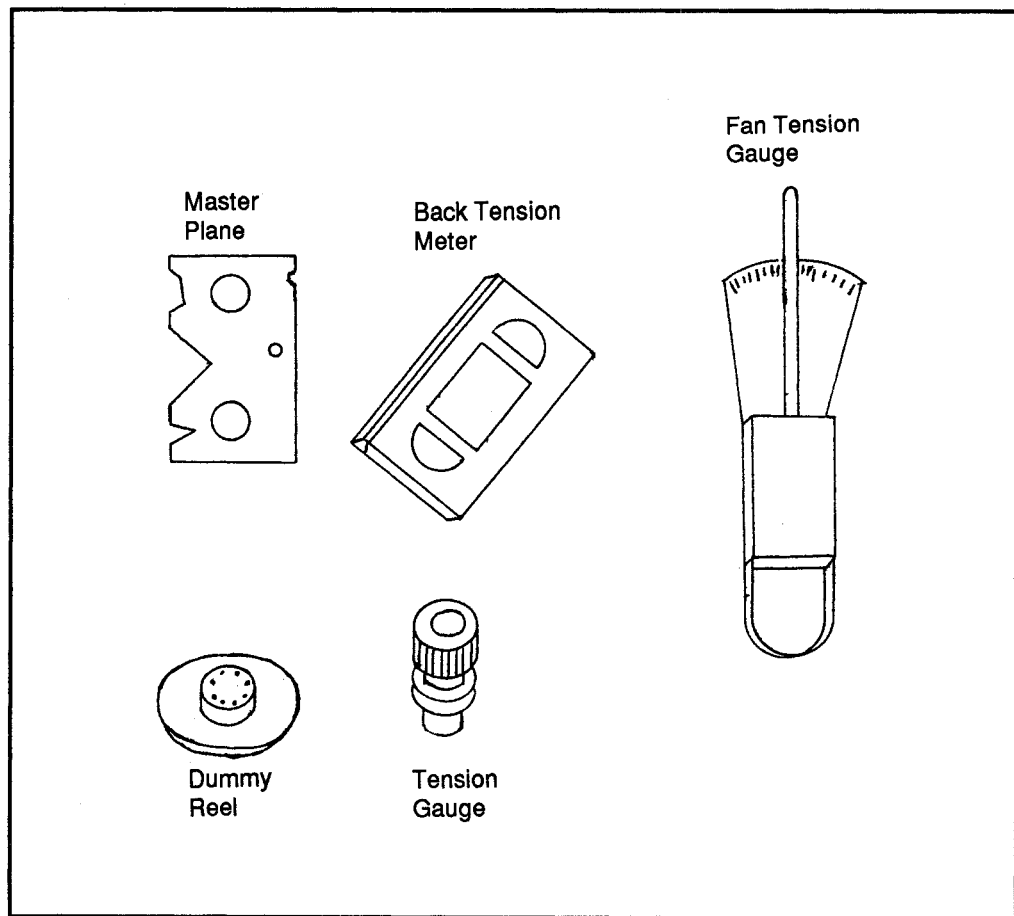
allows you to see the video switching point as related to the beginning of the vertical blanking.

**Various Tools**

Most small metric tools will work well in taking apart and reassembling VCRs. Special tools such as a binding jig, reel tension gauge, 500 and 100 gram spring tension gauges, gear spacer, back tension meter, cassette housing positioning jig, reel disk height jig, torque gauge and adaptor, tension measurement reel and a fan-type tension gauge may be required.

**Alignment Tools**

Mechanical adjustments are machine specific and very complex. There are no universal mechanical adjustments for modern VCRs. Servicing of the circuits is explained in this section as well as an overview of typical mechanical loading sections. A machine specific service manual will be required.



**Figure 1:** Alignment tools

**5/VCR**  
 Video Recorder

5/VCR - TR	Troubleshooting and Repair
5/VCR - TR - AP	Audio Problems
5/VCR - TR - AP - M	Monitoring

---

## 5/VCR - TR - AP

### Audio Problems

---

## 5/VCR - TR - AP - M

### Monitoring

---

Figure 1 shows the audio monitoring circuits. The two audio channel circuits are identical as are the audio record circuits. The Dolby encoder is sampled for monitoring purposes.

The sampled signal without Dolby is sent to the monitor amplifier. The output of the monitor amplifier is sent to an IC that controls the front-panel, monitor-select switch, which allows the user to select from three types of monitoring.

The user can select left and right channels (the default position), right channel only (sent to both left and right outputs), and left channel only (same as right channel only).

Both channels are controlled by an attenuation amplifier which controls the gain from a varied DC current. A higher current will apply more attenuation on the audio signal. This allows for control over the volume of output from the external connectors or the RF connector.

**5/VCR**  
Video Recorder

5/VCR - TR  
5/VCR - TR - AP  
5/VCR - TR - AP - M

Troubleshooting and Repair  
Audio Problems  
Monitoring

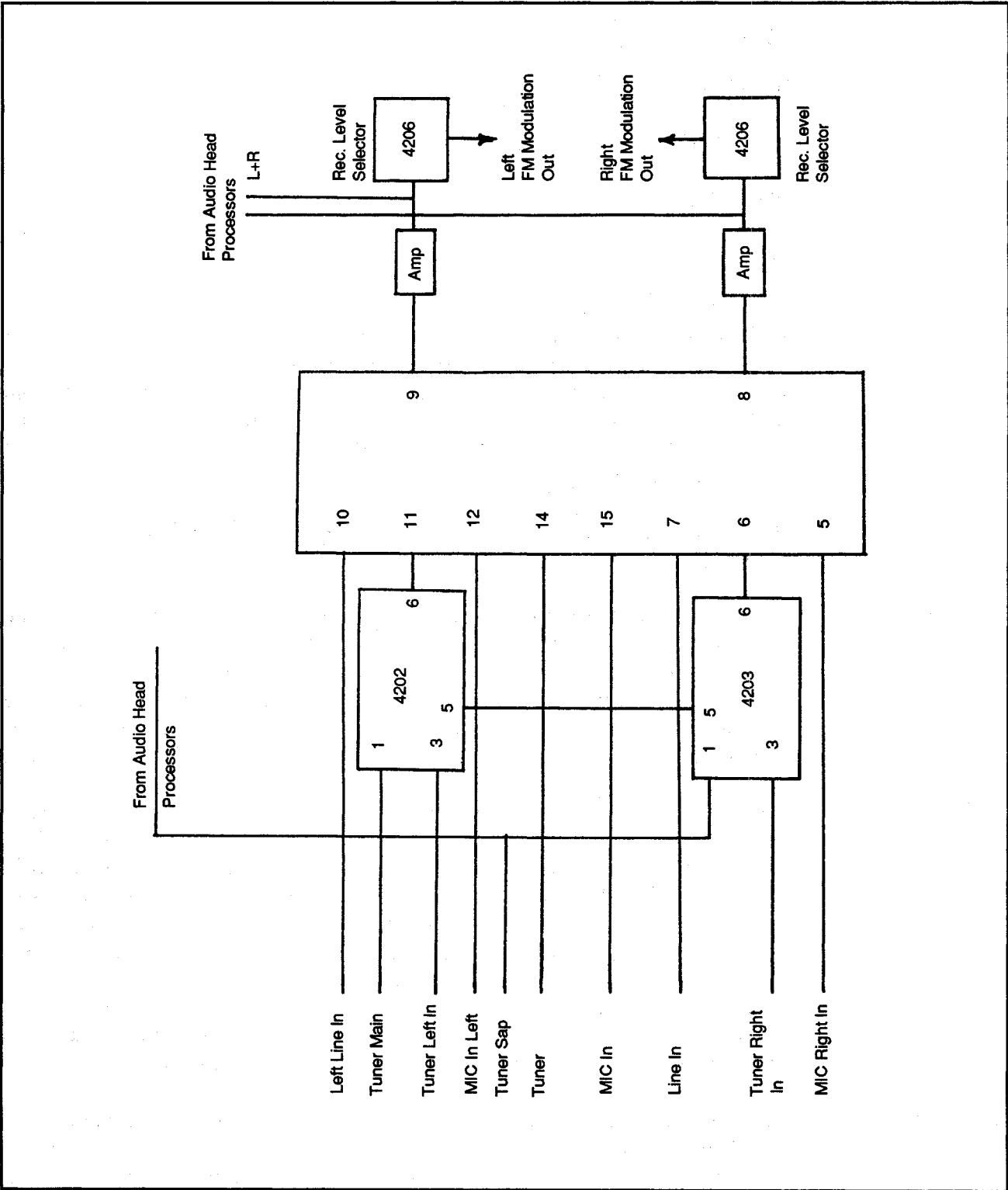


Figure 1: Audio select circuit



5/VCR - TR	Troubleshooting and Repair
5/VCR - TR - AP	Audio Problems
5/VCR - TR - AP - R	Recording

## 5/VCR - TR - AP Audio Problems

---

## 5/VCR - TR - AP - R Recording

---

### Audio Selections

Audio in a VCR is recorded in a many ways. There is mono, linear stereo, and/or Hi-Fi stereo. When hooked to the proper TV or monitor, and possibly your stereo receiver you can have access to each of these audio selections. Audio output can be through the separate audio out for mono, through audio right and audio left outputs for stereo, or through the RF converter which provides video and audio channels. When looking for audio problems, use an audio monitor device and your oscilloscope.

Troubleshooting audio is simply following the audio from one end to the other. Check any adjustments associated with audio circuits first.

### Audio Track

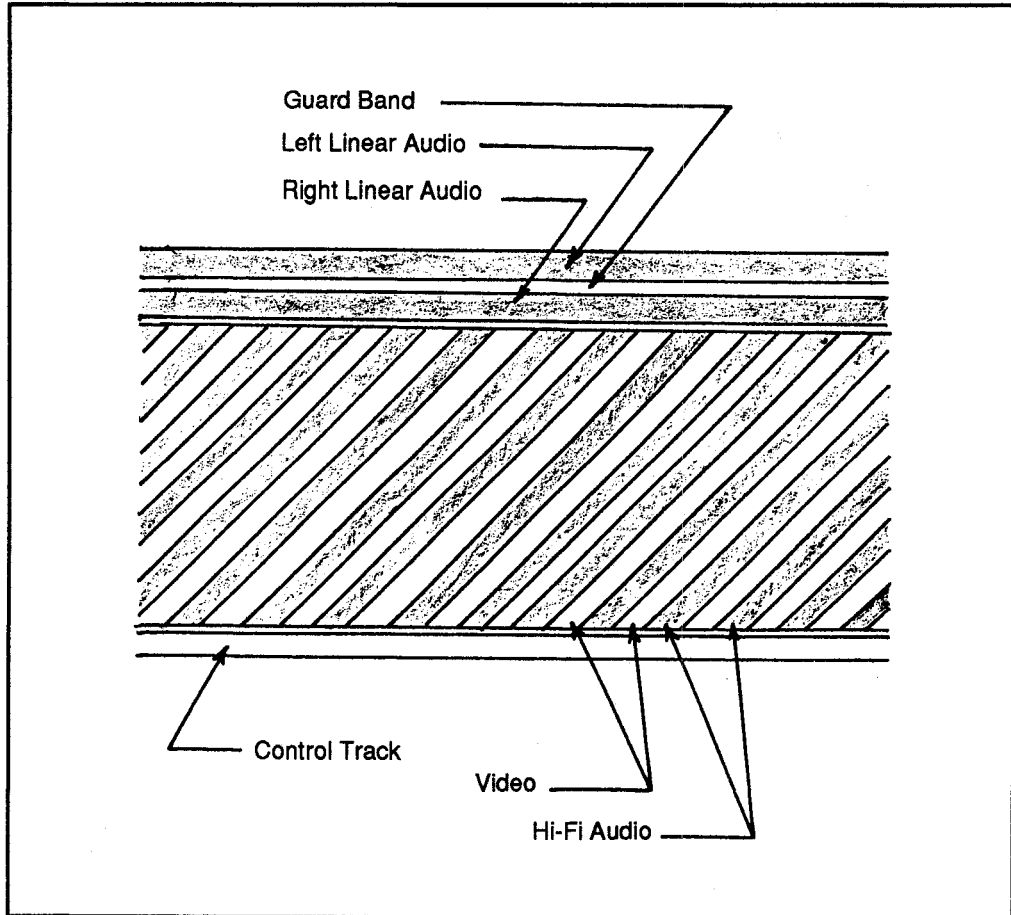
The VHS standard allows for an audio track with a width of 1 mm, recorded on the top edge of a videotape. Mono records on the entire 1 mm space allocated. Linear Stereo records by splitting the left and right signals into 0.35 mm each. This leaves a guard band of 0.3 mm between the audio heads which provides a decent separation of the two audio channels. Hi-Fi audio records along with the video signal via Hi-Fi audio heads in the drum assembly as shown in Figure 1.

### Audio Heads

Audio heads mounted on the drum assembly have a different azimuth (angle) than the video heads. More room is allowed for audio information intermixed with the video information through depth multiplex recording. A typical Hi-Fi VCR can offer a 30 to 40 dB improvement in the S/N (signal-to-noise) ratio. Most units with Hi-Fi audio also have a conventional monaural head to record or play the linear audio portion of the video tape. Because of this, tapes recorded in linear stereo will be played on most Hi-Fi units as monaural. Some units are equipped with both linear stereo and Hi-Fi stereo and can be mixed or played separately. If the unit is playing both linear and Hi-Fi audio, the unit will tend to flange, as the two audio systems do not exit the VCR at the exact same time.

### Standard Linear Audio

Standard linear audio tends to have background or hysteresis noise created by the physical construction of the videotape. This noise occurs in the frequency range of about 5 or 10 kHz. In a monaural VCR this noise is not usually noticed, but



**Figure 1:** Hi-Fi audio as recorded on VHS videotape

in stereo VCRs which have a smaller head size and audio signal strength, background noise can become as great or greater than the audio signal. To help reduce this noise a Dolby noise-reduction system is used (Dolby is not used in Hi-Fi VCRs because of the already improved S/N ratio.)

Most circuits for processing Dolby noise reduction are contained in a single IC. The entire Dolby section must be replaced if found to be bad, as acquiring the single IC is nearly impossible.

Usually, if you are hearing or registering a noise-related problem, check to see that you are playing the tape back in the format in which it was recorded. If recorded with Dolby, play it with Dolby.

If recorded without Dolby, do not use Dolby. If this is not done, distortion will be increased.

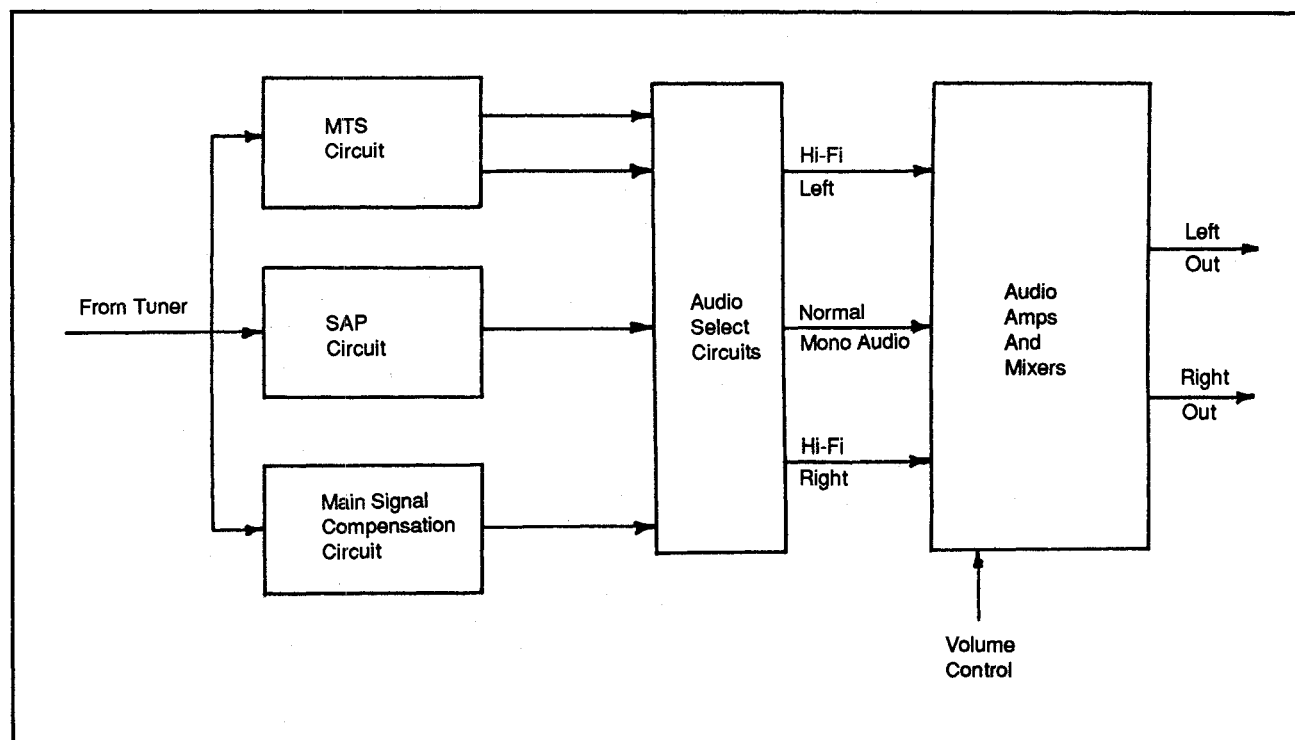


Figure 2: Audio circuits for a typical VHS recorder

### Audio Record Circuit

Figure 2 shows the audio record circuits of a typical VCR. Left and right channel audio circuits are identical. With the exception of the switching circuits, most of the components are IC based.

Source (incoming) audio in a typical VCR starts from either external inputs or tuner inputs and is controlled by a relay. The channel source audio is amplified by the line amplifier within the amplifier IC. The output signal is sent to the Dolby encoder (if used). The combined output signal is sent to the record amplifier (which may be within the same IC as the line amplifier). The output is added to the bias signal from a bias oscillator. The combined signals are then sent to the audio head.

A relay for the left channel may be used to disable the recording of audio information for those units with audio dub. The right channel is recorded on, but the left channel remains untouched when the relay is turned off. When audio dub is selected, the system control disconnects the bias oscillator and the record amplifier from the left-channel audio head only.

### Audio Playback Circuit

Figure 3 shows the audio playback circuit of an average VCR. Both left and right in this section are again identical. Audio travels from the left audio head and is

# 5/VCR

Video Recorder

5/VCR - TR

Troubleshooting and Repair

5/VCR - TR - AP

Audio Problems

5/VCR - TR - AP - R

Recording

outputted to the audio line connector. Grounding is provided to the audio head through a series of transistors. Audio from the audio line connector is amplified by the playback equalizer, the line amps inside the playback equalizer, and the line amplifier. Left-channel audio from the amplifier is sent to the Dolby decoder. The Dolby decoder outputs audio and sends it to the monitor amp.

## Crosstalk Canceller

Some stereo VCRs include a crosstalk canceller circuit. This circuit eliminates the leak of magnetic flux from the right and left channel audio record/playback head during a monaural audio dub. Not all crosstalk can be eliminated—some information may drift between channels.

The output of the right channel is sent to the feedback input, a preamplifier of the left-channel audio section. The feedback is turned on during record or audio dub modes. The feedback signal can be adjusted to the same level as any crosstalk signal that may be appearing at the feedback input. The feedback and crosstalk signals are cancelled because the two signals are of the same amplitude, but at different input levels. If the feedback control is properly adjusted, the feedback signal will have no effect on the left-channel audio. Check the crosstalk alignments if a problem persists after any recording or dubbing.

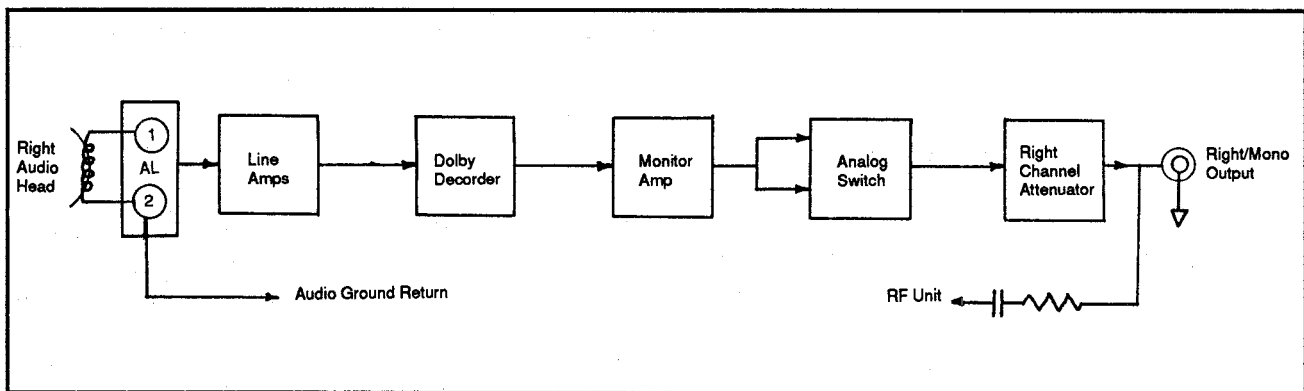


Figure 3: Typical audio circuit for playback



5/VCR - TR	Troubleshooting and Repair
5/VCR - TR - CSP	Control and Servo Problems

## 5/VCR - TR

### Troubleshooting and Repair

## 5/VCR - TR - CSP

### Control and Servo Problems

#### Control Problems

#### Central LSI Controller

All the processing required to do the aforementioned functions occurs in a single LSI chip. Many inputs and outputs inside the LSI chip are unable to be tested. Each of the control signals fed to the LSI must be checked to determine if the problem is in this circuit. A frequency counter and oscilloscope will make this troubleshooting easier. If, in fact, all signals are being sent to the servo IC, and proper adjustment signals are not being produced, the IC is bad and must be replaced. (Be forewarned that mechanical problems can cause erroneous primary information to be sent to the IC.)

The servo timing chart is shown in Figure 1 and a block diagram of the servo and pulse circuits is shown in Figure 2.

#### Servo Problems

#### Typical Problems

The servos are the systems that keep the capstan, drum head and video tape moving at the correct speed. Servo problems can be mechanical and/or electronic. Typical problems in the servo section are a defective motor, incorrect voltage to the motor, loose or worn drive belts, or incorrect speeds.

Begin by checking the belts. Worn or broken belts are the most common cause of servo problems. If this doesn't solve the problem, and there are no obvious solutions (an obviously bad motor, broken wire, etc.), go through alignment procedures discussed in the mechanical adjustment articles.

The drum servo system typically consists of a rotating upper drum to which the video heads are mounted.

Drum servo problems are almost always associated with video problems. With Hi-Fi machines audio problems may also be affected (because the audio is

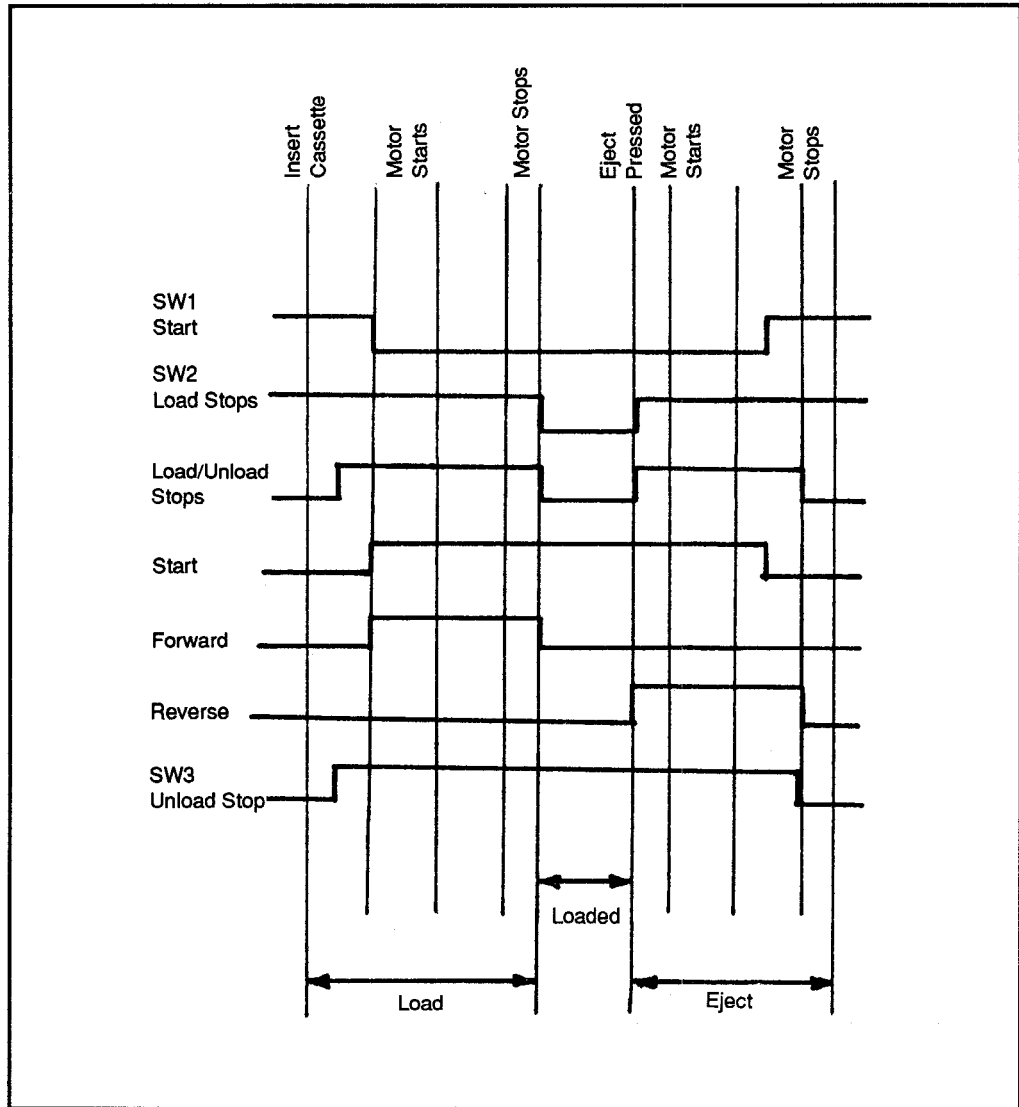


Figure 1: Typical servo timing chart

recorded along with the video signals). Figure 3 shows a typical drum cylinder phase-control circuit.

### Frequency Generator

The drum is controlled by a frequency generator (FG) device which produces a 360 Hz signal. The signal is divided by 12 to produce 30 Hz. It is then compared to a divided vertical sync frequency during record, and a divided 3.58 MHz signal (895 kHz = SP, 447 kHz = LP, 298 kHz = SLP) during playback. The resulting error is sent to the cylinder motor drive circuit to maintain the 30 RPS. This speed is constant regardless of the capstan speed.

**5/VCR**  
Video Recorder

5/VCR - TR  
5/VCR - TR - CSP

Troubleshooting and Repair  
Control and Servo Problems

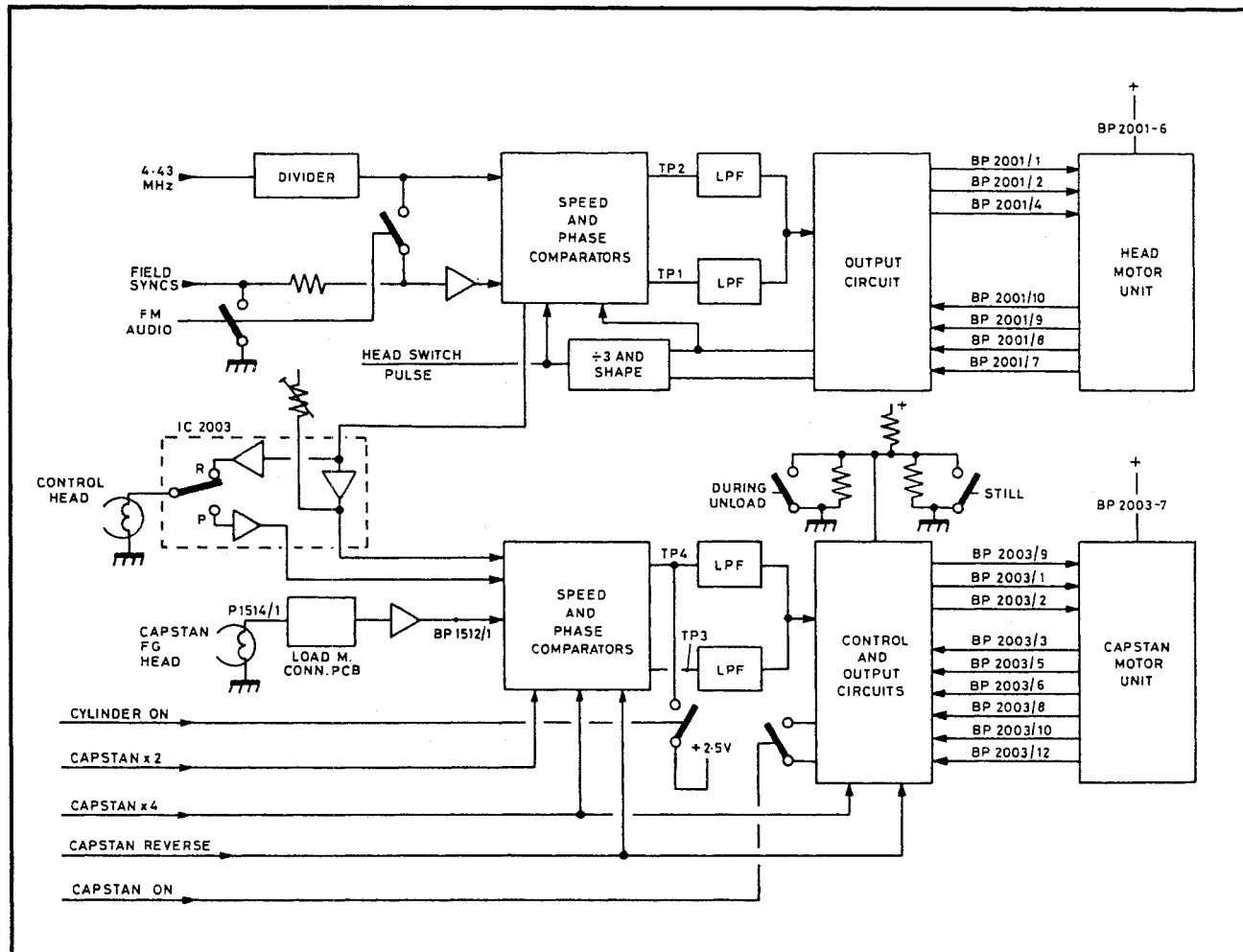


Figure 2: Typical block diagram of servo and pulse circuits

**Pulse Generator**

A pulse generator (PG) pulse signal is generated in the flywheel of the cylinder motor relaying the position of one of the two video head tabs. It is produced by a magnet and pickup coil with each revolution. The PG pulses create another waveform (Figure 4) called the RF switch pulse. To create the RF switch pulse (30 Hz), the positive pulses are used to flip-flop the video head during playback.

During playback, when the waveform is in the negative cycle, the track 1 head is switched on. The track 2 head is on during the positive cycle. By adjusting the pulse generator monostable multivibrator (PG MM) control, the position of the switch point where each head is turned on can be placed at the required 6.5 horizontal lines before vertical sync. During recording the motor phase control is set by comparing half of the vertical sync (30 Hz) with the 30 Hz PG signal.

It may be necessary to make adjustments to the cylinder phase while the VCR is in the forward and reverse search modes. You will be trying to lock the noise bar in one position so it does not enter the vertical interval. The reference 30 Hz signal is adjusted to 29.49 Hz in forward search and 30.51 in reverse search.

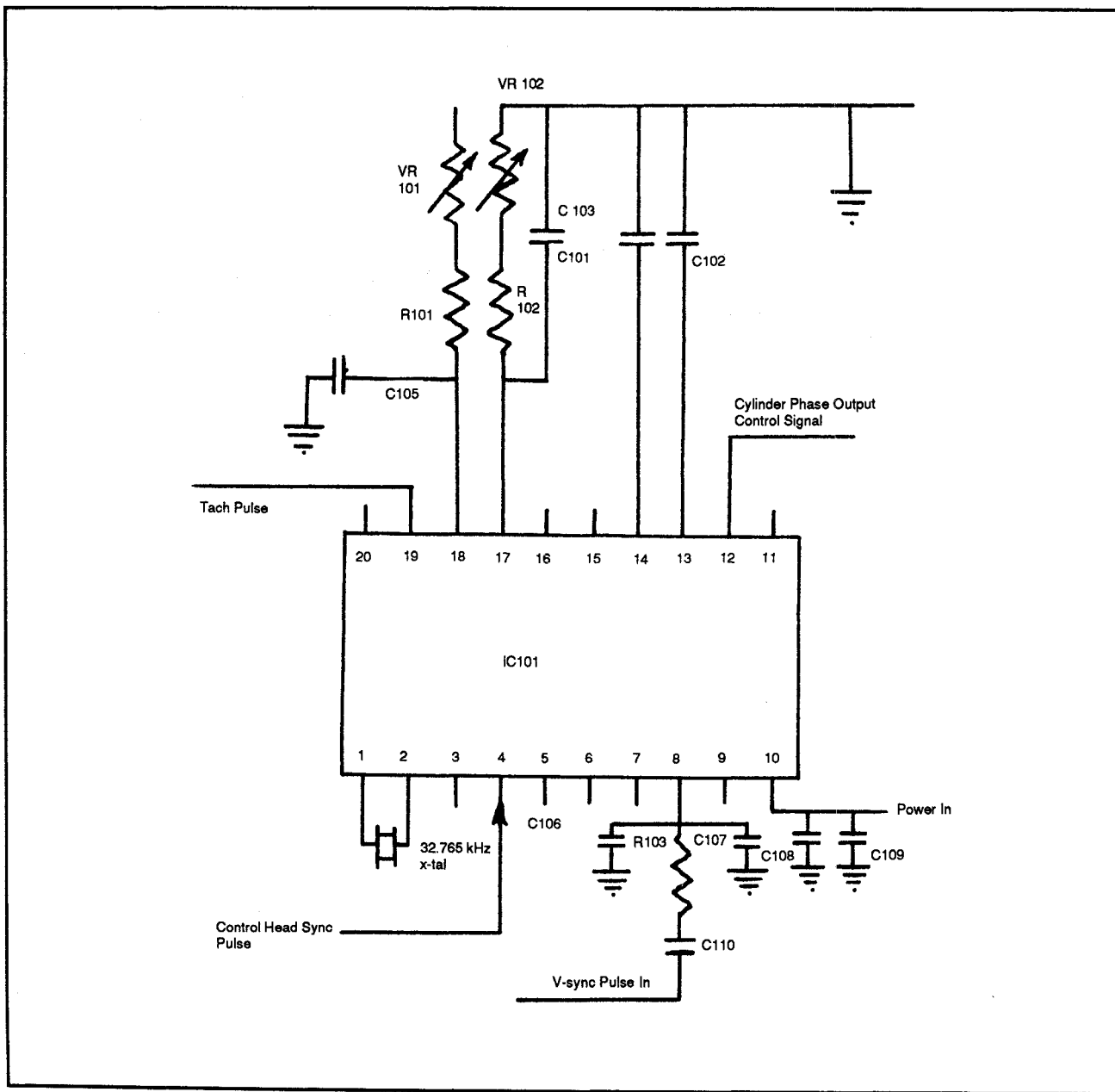


Figure 3: Drum cylinder phase-control circuit

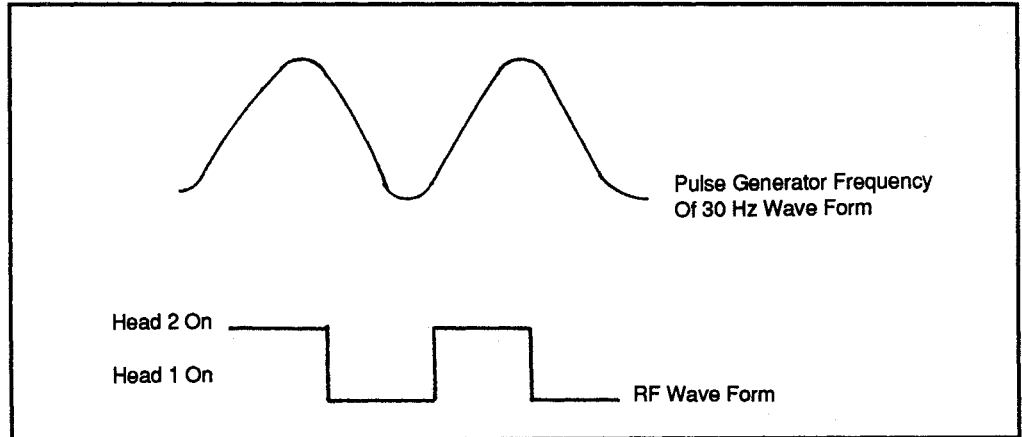
**5/VCR**  
Video Recorder

5/VCR - TR  
5/VCR - TR - CSP

Troubleshooting and Repair  
Control and Servo Problems

**Capstan Digital Speed**

The capstan digital speed is created in a fashion similar to that of the drum cylinder drive circuit. The speed select circuit controls the division of the 3.58 reference signal to achieve the needed frequencies.



**Figure 4:** PG pulse waveform

**5/VCR**  
Video Recorder

---

5/VCR - TR

Troubleshooting and Repair

---

5/VCR - TR - CSP

Control and Servo Problems

---

# 5/VCR

Video Recorder

5/VCR - TR	Troubleshooting and Repair
5/VCR - TR - MA	Mechanical Adjustments
5/VCR - TR - MA - HA	Height Adjustments

## 5/VCR - TR - MA

### Mechanical Adjustments

## 5/VCR - TR - MA - HA

### Height Adjustments

**Reel Table Height** To adjust the reel table height, you will need to use the reel table height jig and the reference height plate. The height of the reel table is adjusted by changing the washer stack located under each reel table. Begin by placing the height reference plate into the VCR. Place the height reference jig on the plate and check the reel table height. If the reel height needs to be changed, this can be accomplished by using the two sizes of washers available (0.25 mm and 0.5 mm reel table washers are available).

**Tape Guidepost Height Adjustment** The height reference plate will be needed. Place the plate in the VCR. Adjust the nut on top of the guidepost for a clearance of  $0 \pm 2$  mm.

**Impedance Roller Height Adjustment** The height reference plate and reel table height gauge will be used. Install the height reference plate into the VCR. Place the reel table height gauge on the height reference plate. The nut on top of the impedance roller should be adjusted for a clearance between 1.5 and 2.5 mm.

**Interchangeability Checks** The confirmation check is only performed after any service operation which could affect the tape. Such servicing may include tape guide replacement, head replacement, reel replacement, etc. If this test passes, (and there is no tape creasing or frilling), then no tape guide adjustment is necessary. The tracking preset adjustment should be made before this adjustment. Refer to the service manual for the proper test point.

Both channels of the scope are used. A monoscope test tape is inserted and played. The tracking control is adjusted counterclockwise for a maximum FM envelope (which is monitored by channel B of the scope).

The maximum envelope amplitude will be 3 graticule divisions. The minimum envelope amplitude will be 1.6 graticule divisions. The tracking control is turned clockwise until a maximum envelope amplitude of 3 graticule divisions is obtained.

The minimum envelope amplitude should be 1.6 graticule divisions.



5/VCR - TR	Troubleshooting and Repair
5/VCR - TR - MA	Mechanical Adjustments
5/VCR - TR - MA - HA	Height Adjustments



**5/VCR**  
Video Recorder

5/VCR - TR	Troubleshooting and Repair
5/VCR - TR - MA	Mechanical Adjustments
5/VCR - TR - MA - TA	Tension Adjustments

**5/VCR - TR - MA**  
**Mechanical Adjustments****5/VCR - TR - MA - TA**  
**Tension Adjustments****Tension Arm  
Adjustments**

The tension arm adjustment is done with the VCR in the play mode without a cassette. The tape-end sensor should be covered with black tape. The VCR loading mechanism will have to be loaded before the VCR will go into play.

For camcorders, simply close the cassette holder. For VCRs trip the load sensor switch so the cassette will load.

Place the unit in the play mode by pressing play. The tape transport will load. Loosen the screw holding the tension band holder. Adjust so the clearance

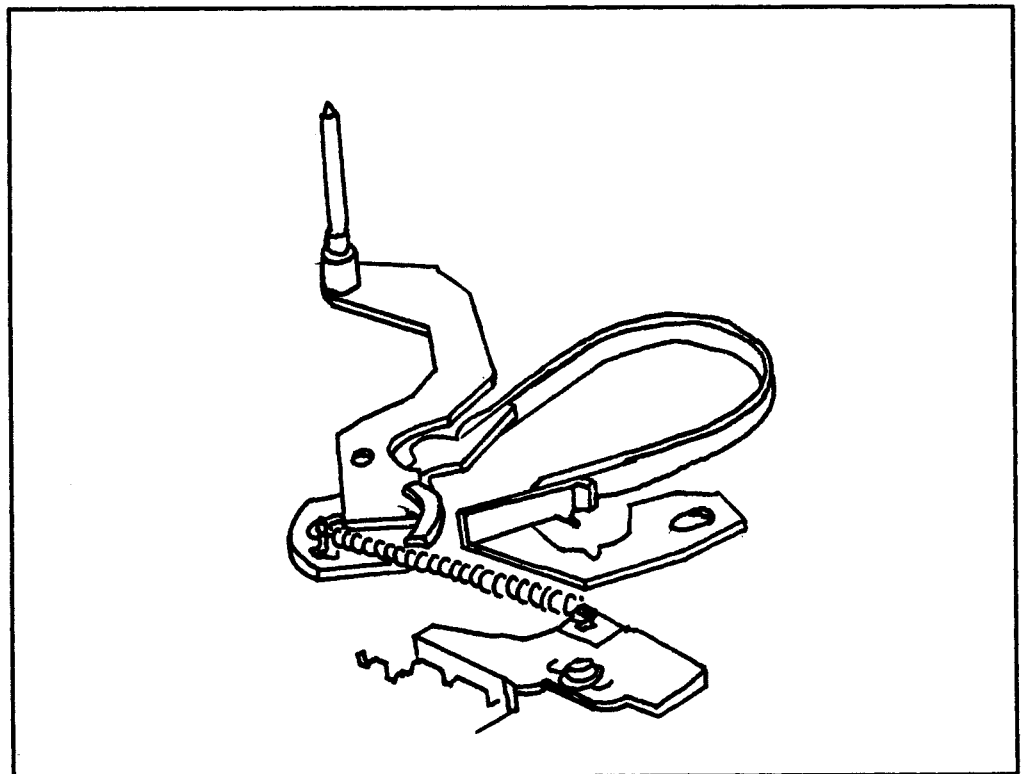


Figure 1: Back tension spring



5/VCR - TR	Troubleshooting and Repair
5/VCR - TR - MA	Mechanical Adjustments
5/VCR - TR - MA - TA	Tension Adjustments

between the tension arm and section A of the supply end sensor holder is 0.6 to 1.2 mm. Tighten the screw and remove the tape from the tape-end sensor.

### Back Tension

The back tension spring is shown in Figure 1. Proper alignment will ensure proper playback of the service tape. Playback will be with minimum skew error (the picture displacement in the line following head switching) when this alignment is correct.

Once one of the back-tension tapes is inserted into the VCR, press play. The reading on the gauge should be between 27 and 38 on gauge A, or between 23 and 32 on gauge B. If the reading is higher than 45 on gauge A, or higher than 33 for gauge B, adjust the tension arm spring. This should restore back-tension to within tolerance levels. If the tolerance is still outside specs, check the tension arm for proper alignment (as previously described).

# 5/VCR

Video Recorder

5/VCR - TR	Troubleshooting and Repair
5/VCR - TR - MA	Mechanical Adjustments
5/VCR - TR - MA - TC	Torque Checking

## 5/VCR - TR - MA

### Mechanical Adjustments

## 5/VCR - TR - MA - TC

### Torque Checking

#### Brake Torque

Checking the brake torque requires the VCR to be in the stopped mode. The brake surfaces on the reel table should be clean. Place the torque gauge on the supply reel and turn the gauge clockwise until the brake begins to slip against the reel table. The torque reading should be greater than 140 g/cm. Place the torque gauge on the take-up reel table and turn the gauge counterclockwise. The torque reading should be greater than 80 g/cm.

If the torque readings are less than the specifications for the VCR, the tape would stretch, spill or break. A good cleaning of the brake area can usually correct this. (Note: do not get the felt pads wet). If the problem persists, the brakes will need to be replaced.

#### Play, Fast Forward and Rewind Torque Checks

To begin this test, cover the tape end sensors with black tape. Place the torque gauge on the take-up reel, press play, and read the torque gauge. The reading should be between 80 and 110 g/cm. With the VCR in the fast-forward mode, the reading will be about 400 g/cm or greater.

The torque gauge should now be placed on the supply reel. Press rewind and measure the torque. The reading should be about 400 g/cm.

The tape slack torque can be checked at this point as well. Stop the VCR and leave the gauge on the supply reel. Rotate the torque gauge clockwise and check the reading. It should be between 90 and 200 g/cm.

Next, press the fast-forward button (FF) and rotate the torque gauge clockwise. The reading should be between 4 and 10 g/cm. Check the supply reel with the VCR in the rewind mode for the same reading. (These readings may be hard to get depending upon which type of gauge you may be using.)

**5/VCR**  
Video Recorder

5/VCR - TR	Troubleshooting and Repair
5/VCR - TR - MA	Mechanical Adjustments
5/VCR - TR - MA - TC	Torque Checking

# 5/VCR

Video Recorder

5/VCR - TR	Troubleshooting and Repair
5/VCR - TR - MA	Mechanical Adjustments
5/VCR - TR - MA - TT	Tape Transport

## 5/VCR - TR - MA

### Mechanical Adjustments

## 5/VCR - TR - MA - TT

### Tape Transport

The two most common problems involve either poor cleaning practices or cassette malfunction. When a tape is placed into a VCR, a switch senses the insertion and triggers motors and mechanisms to grab the cassette, pull it inside and lower it onto the platform. As this happens, the cassette door is released and opened. At the same time a pin unlocks the cassette reels.

When the Play button is pressed, the tape transport removes the tape from the cassette's supply reel and routes the tape through a series of posts and guides which are aligned precisely to put the tape in contact with the erase, video, audio and tracking heads. Movement of the tape is monitored by sensors in the tape transport path which relay the status of the video tape to a microprocessor.

The loading ring controls all of the active transport elements in a VHS recorder. It is responsible for the removal of the tape from the cassette as well as placing the tape in contact with the heads.

As the tape is pulled from the cassette, it comes in contact with a fixed guide post, the supply tension arm, and with an upper and lower positioning flange. The tape continues past the full-erase head and the pressure idler which supplies the tension needed to keep the tape in contact with the guide roller. The last stop before coming in contact with the rotary heads is the input slant-guide post which provides the proper angle of tape to the drum assembly.

On the drum assembly, located on the lower stationary (nonrotating) section, is a precision helical groove. This guides the tape around the drum.

As the tape exits the drum assembly, it passes over the exit slant-guide posts which position the tape for returning to the cassette. On the return travel, the tape passes the linear audio/control head, a fixed take-up guide post, and the capstan drive shaft. The tape is held against the capstan drive shaft by a pinch roller. The capstan pulls the tape through the VCR at a predetermined, constant speed.

**5/VCR**  
Video Recorder

5/VCR - TR	Troubleshooting and Repair
5/VCR - TR - MA	Mechanical Adjustments
5/VCR - TR - MA - TT	Tape Transport

When Stop is pressed, and the tape leaves the transport deck, it is pulled back into the cassette by the loading ring. The loading ring is driven by the loading motor, which controls a belt and pulley coupling. A mechanical brake located next to the loading ring applies tension to the loading ring when in the stopped mode. It also serves as a mechanical brake for the supply reel.

# 5/VCR

Video Recorder

5/VCR - TR

Troubleshooting and Repair

5/VCR - TR - VP

Video Processing

5/VCR - TR - VP - C

Color

## 5/VCR - TR - VP

### Video Processing

## 5/VCR - TR - VP - C

### Color

#### Color Circuit Operation During Record

Figure 1 shows how the video from the tuner is passed to remove and amplify the chroma signal only. It is then boosted by 6 dB. The automatic chroma control (ACC) circuit then receives the chroma burst signal through. The signal is sent to the chroma control detector circuit.

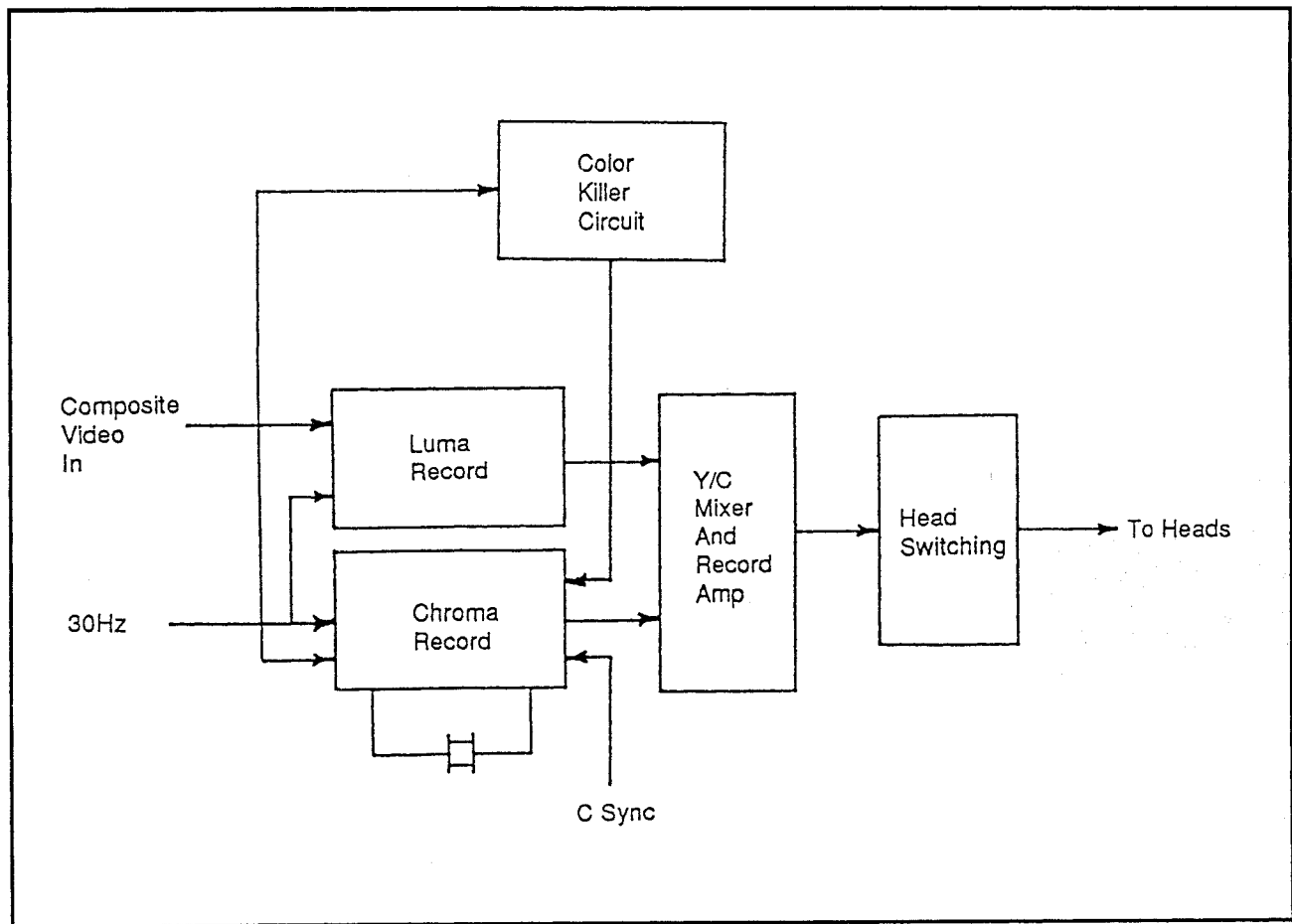


Figure 1: Chroma circuit during record

The peak of the chroma signal is detected and produces a control voltage which is sent to the ACC circuit to maintain the chroma signal at a certain voltage level. The chroma signal is sent to the main converter and mixed with a reference signal, which then produces a 629 kHz for recording on tape with the luminance signal.

The reference signal is created by mixing a 3.58 MHz signal from a variable crystal oscillator (VCO) and a 629 kHz signal. The 629 kHz signal is reversed  $\pm 90^\circ$  every single horizontal period (1H). When all the aforementioned signals are combined, they produce a 4.2 MHz signal that is passed through a bandpass filter to the main converter where it is combined with the 3.58 MHz chroma signal to produce 629 kHz. The combined signal is then fed to the record amplifier.

**Color Killer Circuit** Figure 2 shows the color killer circuit. It is designed to prevent the passing of a color signal when the signal is black and white only. It also provides an ID pulse, which is used in the AFC circuit to prevent a  $180^\circ$  out-of-phase lockup.

During black and white operation there is no 3.58 MHz color burst signal so the phase detector color killer only sees the luminance signal. When this happens, the passage of color signals is prevented.

During color operation the 3.58 MHz color burst is sent through the burst gating circuit, along with a reference 3.58 MHz signal, to the phase detector killer. The signals are compared, and if they match, the output allows the color signal to pass. The color burst is exactly  $180^\circ$  out of phase with the reference 3.58 MHz signal.

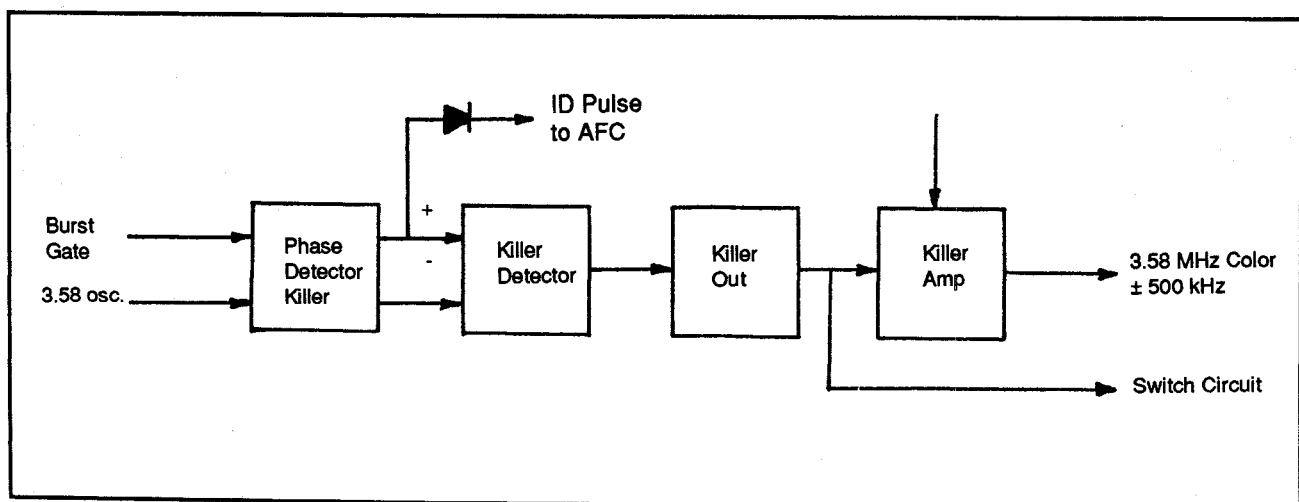


Figure 2: Typical color killer circuit



# 5/VCR

Video Recorder

5/VCR - TR

Troubleshooting and Repair

5/VCR - TR - VP

Video Processing

5/VCR - TR - VP - FPC

Frequency and Pulse Control (Automatic)

## 5/VCR - TR - VP

### Video Processing

## 5/VCR - TR - VP - FPC

### Frequency and Pulse Control (Automatic)

#### AFC

Figure 1 shows a block diagram of the typical AFC circuits in a VCR. AFC works similarly in record and playback. It uses H-sync pulses in the video signal from the tuner during record. During playback the H-sync signals on the tape are used.

There are five inputs to the one output of an AFC circuit. Inputs are the video H-sync pulses, a 30 Hz cylinder signal from the servo, a 3.58 MHz fixed or phase corrected signal from the variable crystal oscillator (VXO) in the automatic phase control (APC) circuits, a color burst ID pulse from the APC and a dropout pulse from the DOC circuit.

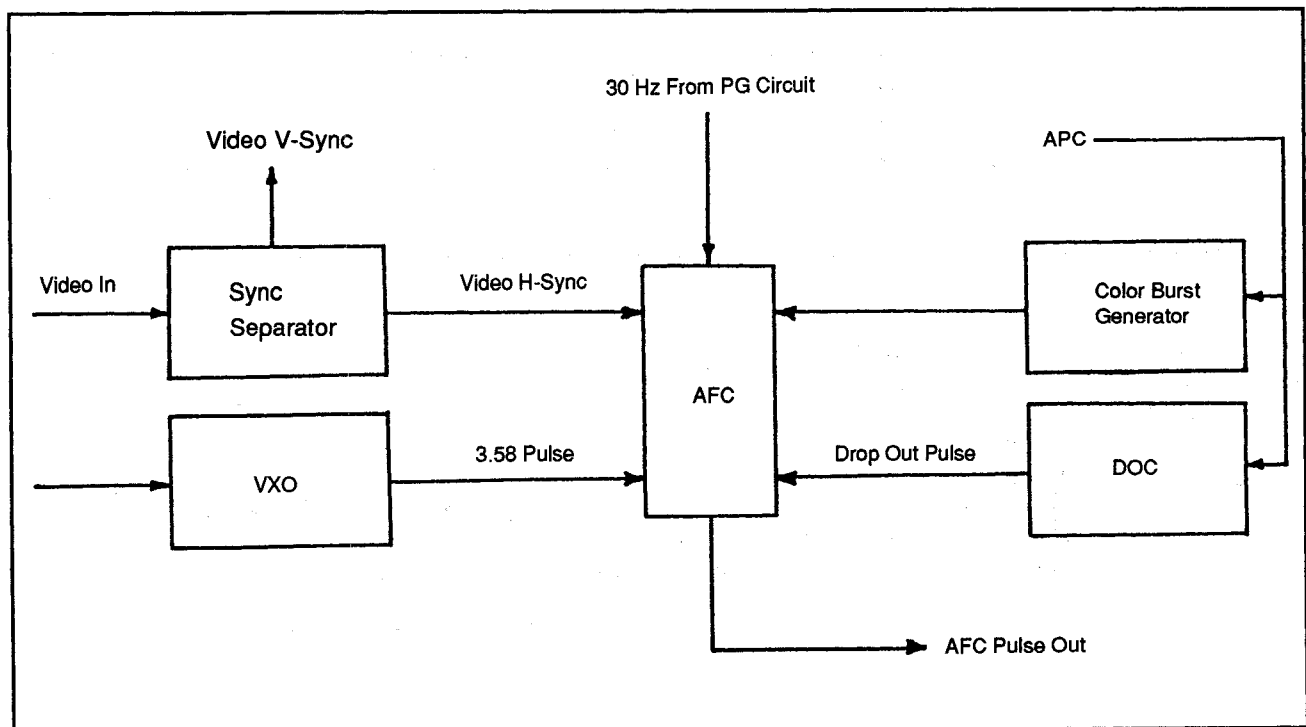


Figure 1: Automatic frequency control circuit

# 5/VCR

Video Recorder

5/VCR - TR

Troubleshooting and Repair

5/VCR - TR - VP

Video Processing

5/VCR - TR - VP - FPC

Frequency and Pulse Control (Automatic)

The video signal is split into separate vertical and horizontal sync. The H-sync (fH) signal is shaped into a  $2\mu\text{s}$  pulse by a horizontal drive circuit, and also sent to an AND gate. The second AND gate is kept normally high so the  $2\mu\text{s}$  fH pulse can pass. If a dropout occurs, the AND gate goes low and the fH signal cannot pass. The AFC also receives a horizontal prime (fH') signal created by a 2.5 MHz VCO.

The 2.5 MHz signal is 160 times the H-sync frequency. The signal is divided into 4 equal 629 kHz signals through a  $1/4\ 90^\circ$  shift and switch circuit operated

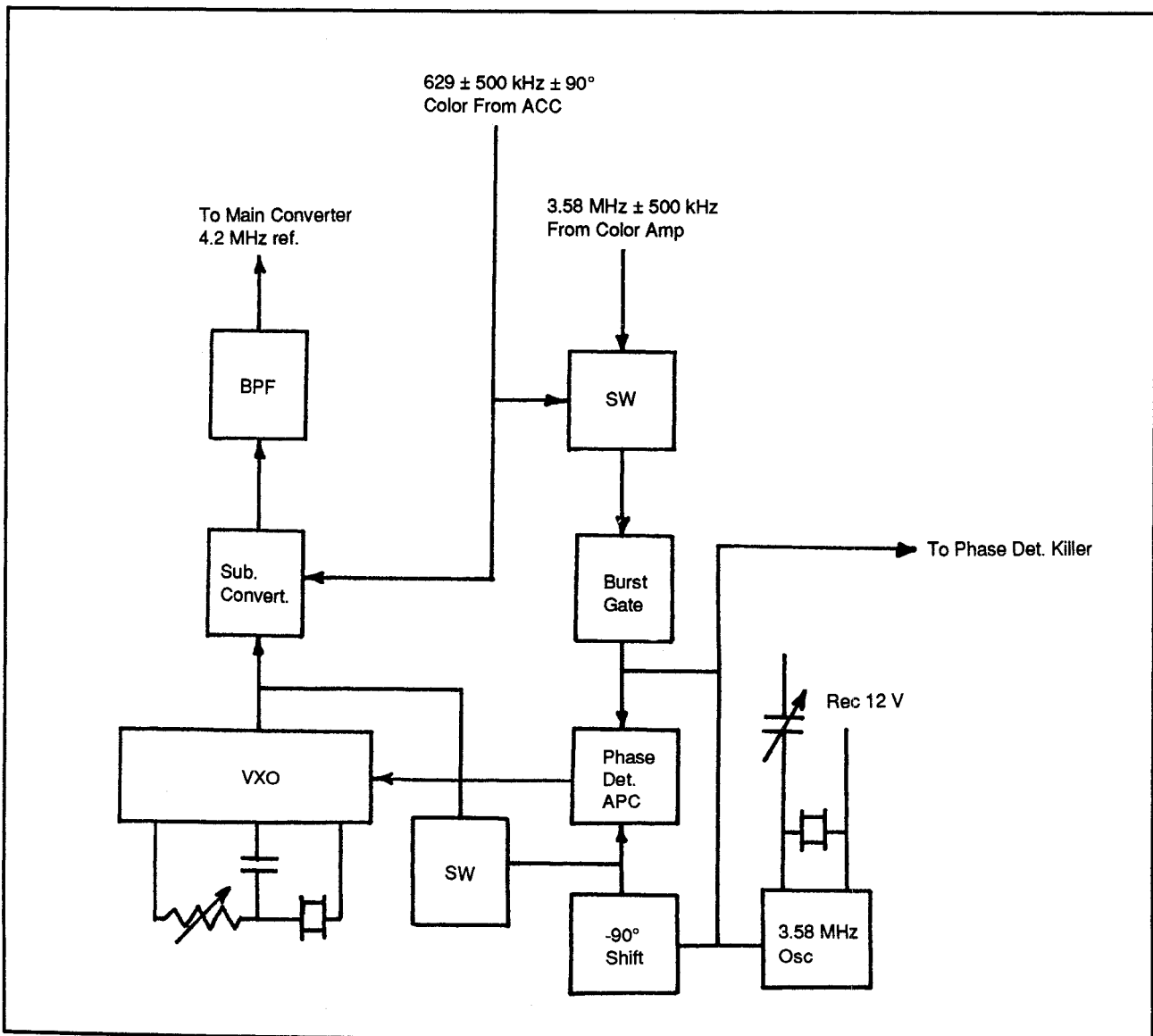


Figure 2: Automatic pulse control circuit

# 5/VCR

Video Recorder

5/VCR - TR	Troubleshooting and Repair
5/VCR - TR - VP	Video Processing
5/VCR - TR - VP - FPC	Frequency and Pulse Control (Automatic)

by a 4 bit counter. The output is then divided to 1/10 or 6.29 kHz and by 1/4 of this or 15.625 kHz. If there is any difference between the fH signal from the AND gate and the fH' signal originating at the VCO, the VCO is shifted in frequency by an error correction voltage created in the AFC circuit. This locks the VCO precisely on the horizontal sync frequency.

The 4-bit counter produces switch signals that select each of four signals in order from the 1/4 90° shift circuit. Each of the four signals is shifted 90° from the prior signal. Channel 1 is advanced in phase by 90° but channel 2 signals are delayed in phase by 90°.

## APC

Figure 2 shows a typical automatic pulse control (APC) circuit. This circuit will correct any phase differences between the reference 3.58 MHz signal from the VXO and the incoming signal 3.58 MHz.



---

5/VCR - TR	Troubleshooting and Repair
5/VCR - TR - VP	Video Processing
5/VCR - TR - VP - FPC	Frequency and Pulse Control (Automatic)

---

# 5/VCR

Video Recorder

5/VCR - TR	Troubleshooting and Repair
5/VCR - TR - VP	Video Processing
5/VCR - TR - VP - LC	Luminance Circuit

## 5/VCR - TR - VP

### Video Processing

## 5/VCR - TR - VP - LC

### Luminance Circuit

#### Basic Function

A typical luminance circuit is shown in Figure 1, in the article "Phase Inversion", (5/VCR - TR - VP - PI). The video signal from the video input is sent to the preamps. Each channel is amplified to remove any overlapping signal and sent to the video amplifier and color circuits. The signal is reduced to the luminance signal only by passing through a 3.58 MHz trap. The pure video signal is amplified and fed to the nonlinear emphasis circuit which emphasizes the luminance signal frequencies by different amounts depending on the record mode.

The output of the nonlinear emphasis circuit is then adjusted to a proper FM modulated level (4 and 6 hour record modes only). The signal is then amplified by the video amplifier and sent to a clamp where the DC voltage of the video sync tip remains constant. This maintains a sync tip of 3.4 MHz.

Next, the clamped signal passes to the pre-emphasis network where the high frequency spectrum is emphasized to improve the S/N ratio. (This reduces noise.) The signal is then processed by the white and dark clip circuits. The white and dark clip circuits reduce the possibility of overshooting a specific level. The signal leaves the white and dark clip circuits and is applied to the FM modulator (which operates at 4.4 MHz for white peaks and at 3.4 MHz for sync tips). There are also 30 Hz pulses being received from the FM carrier interleaving circuits.

The FM luminance signal is amplified and attenuated to reduce the lower end of the FM so it does not interfere with the 629 kHz chroma signal. The signal then passes through the squelch circuit (which prevents accidental record during a tape load function), and is amplified and combined with the chroma signal. The combined signal is sent to the video heads via the rotary transformers.

#### Luminance Circuit During Playback

A typical luminance circuit during playback is shown in Figure 1. The reproduced signal is sent to the preamps from the rotary transformers. Each channel is amplified to remove any overlapping signal and sent to the video amplifier and color circuits. It is then sent to a drop out compensator (DOC) circuit. The DOC prevents picture deterioration by supplying a preceding signal if the FM signal

**5/VCR**  
Video Recorder

5/VCR - TR  
5/VCR - TR - VP  
5/VCR - TR - VP - LC

Troubleshooting and Repair  
Video Processing  
Luminance Circuit

is partially missing. It also sends a pulse to the automatic frequency control (AFC) circuits.

The FM signal is fed to a high-pass filter, first limiter, low-pass filter, mixer, and second limiter, which removes the AM from the FM signal. It is then fed to the demodulation circuit. The demodulated signal is amplified and impedance is matched. The video signal is deemphasized by the deemphasis circuit. Then an edge noise canceller removes any noise, and the video signal is sent to a compensator circuit.

The signal is transmitted through the noise canceller circuit, which cuts down any noise in the video signal. The luminance (Y) and chroma (C) signals are processed in the Y/C mixer and then sent to the E-E/V-V switch through the clamp mute circuit. Output from the E-E/V-V signal is sent to the RF modulator which will produce the NTSC signal on the selected channel.

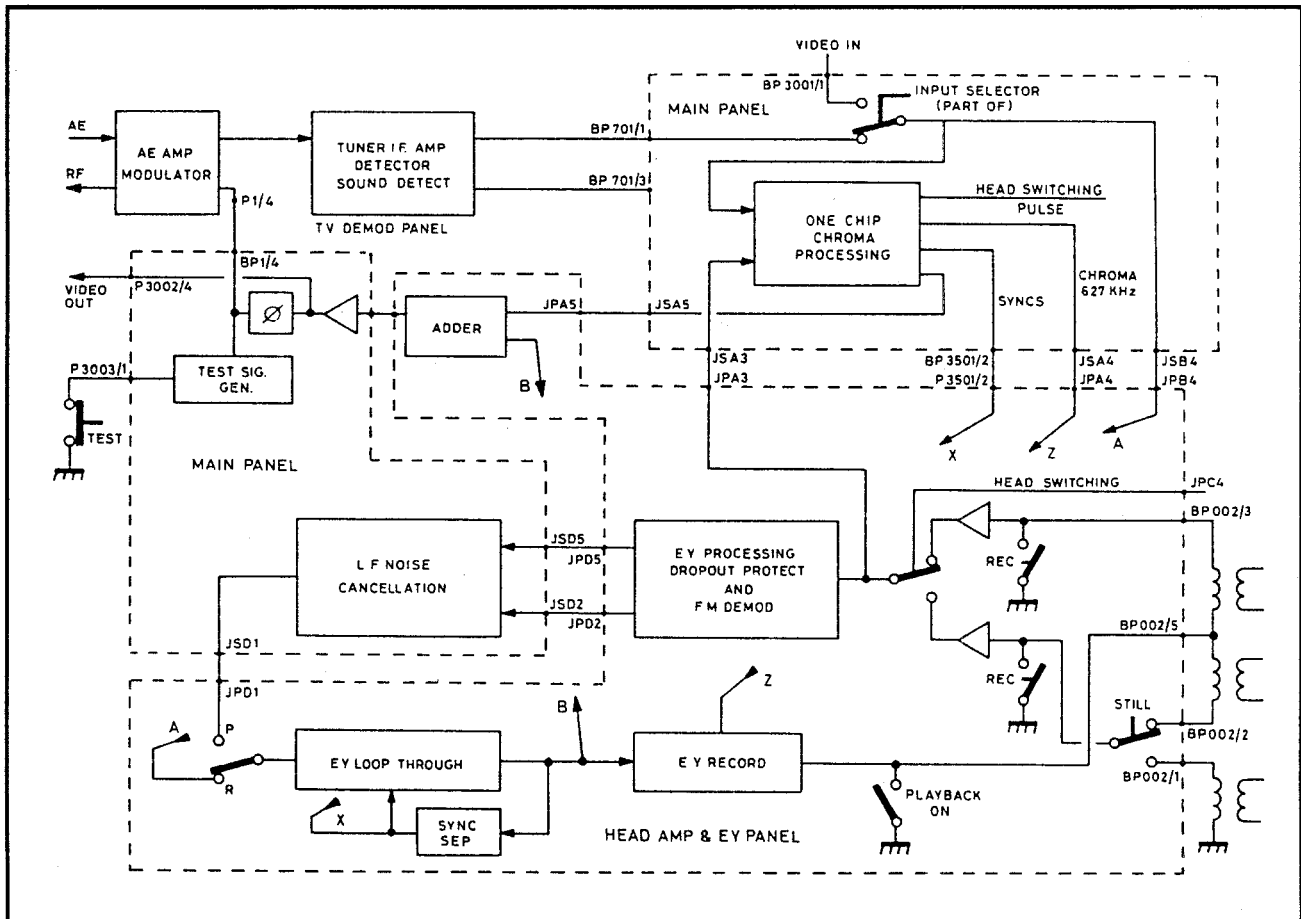


Figure 1: Luminance circuit during playback

**5/VCR**  
Video Recorder

5/VCR - TR

Troubleshooting and Repair

5/VCR - TR - VP

Video Processing

5/VCR - TR - VP - PI

Phase Inversion

**5/VCR - TR - VP**  
**Video Processing**

**5/VCR - TR - VP - PI**  
**Phase Inversion**

Phase inversion is used to minimize crosstalk. This happens mainly in the chroma channel which tends to crosstalk more than other channels.

The chroma signal recorded on the A track (tracks alternate A and B) is phase-inverted by 90° with each line period (1H). The B channel is recorded in reverse phase of the A channel (or opposite phase direction). During playback, the A and B channels are restored to the same phase. Figure 1 shows how the chroma signal is recorded using phase inversion.

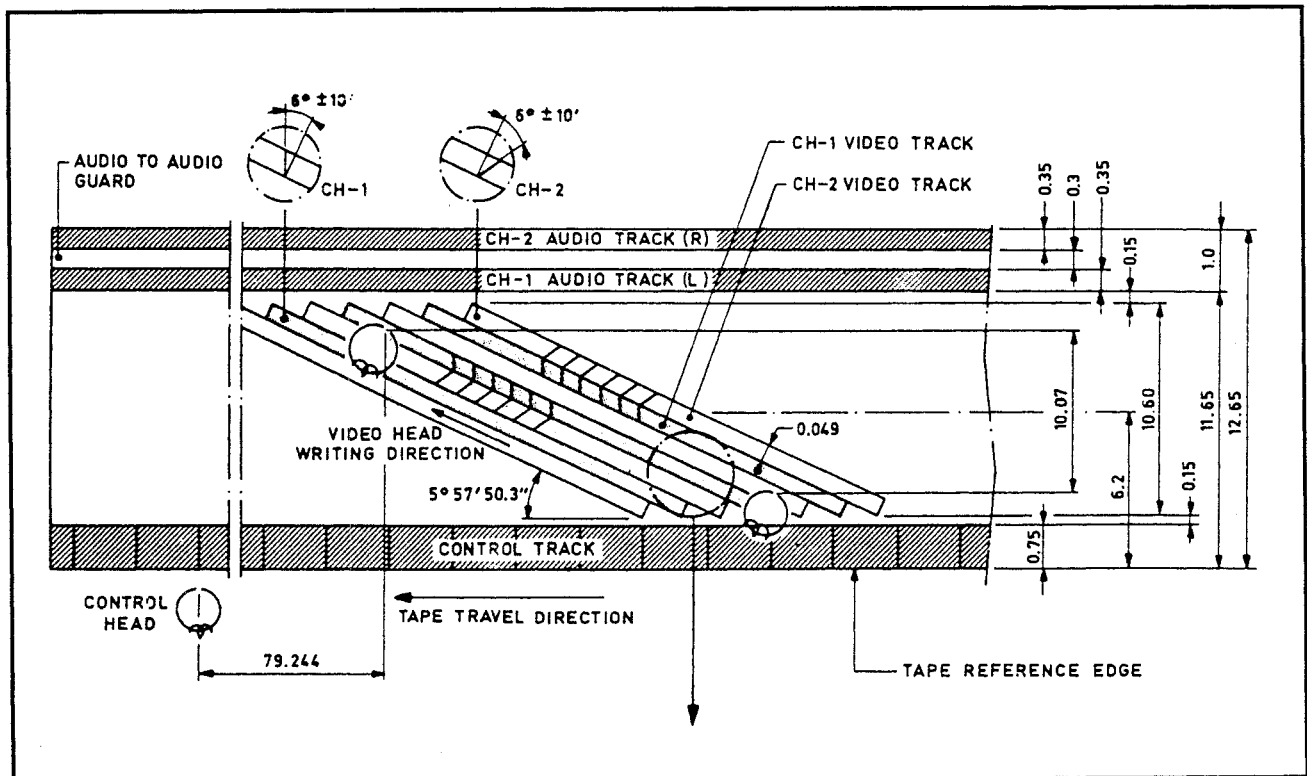


Figure 1: Phase inversion as recorded on a VHS machine

**5/VCR**  
Video Recorder

5/VCR - TR  
5/VCR - TR - VP  
5/VCR - TR - VP - PI

Troubleshooting and Repair  
Video Processing  
Phase Inversion

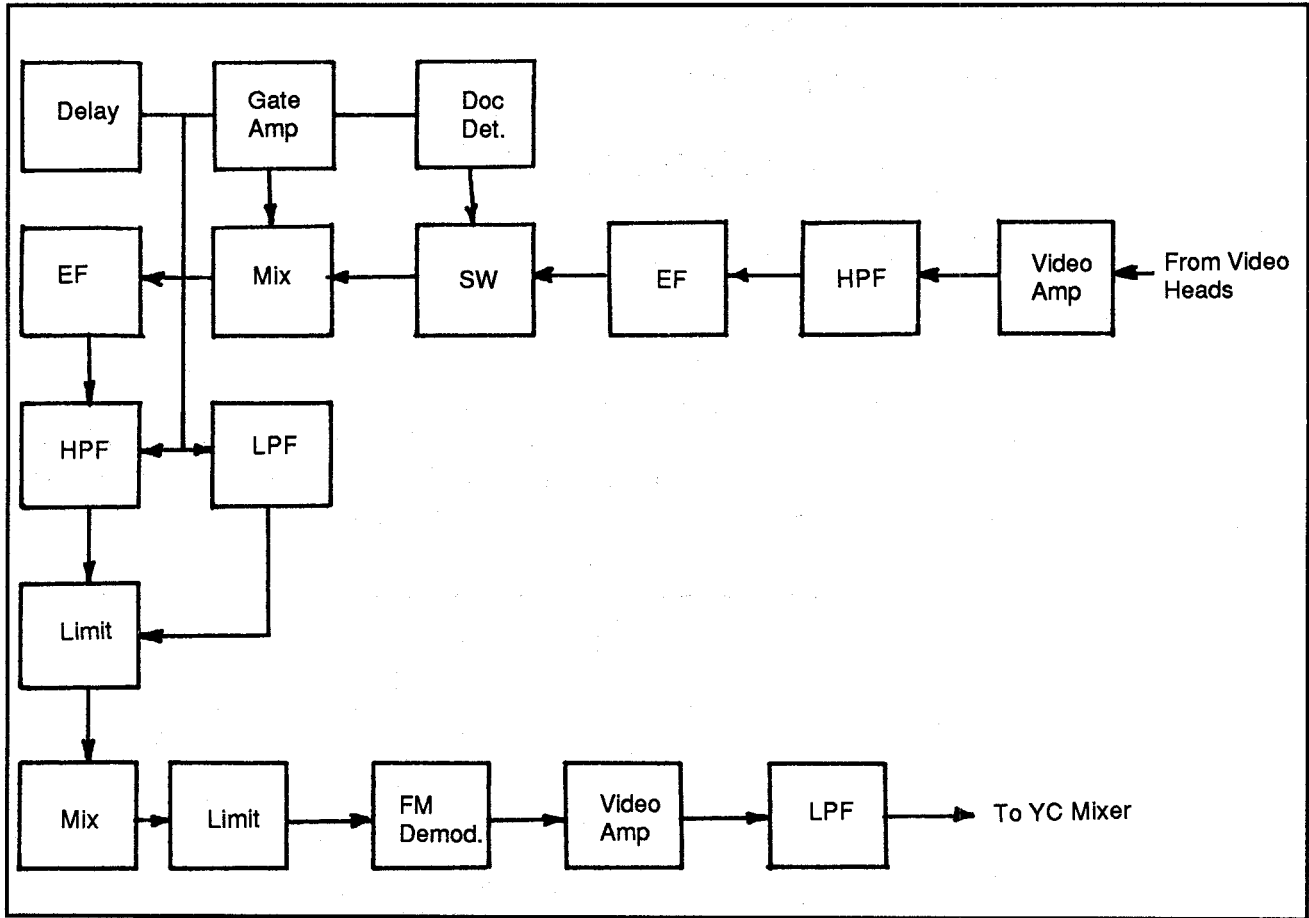


Figure 2: Typical luminance circuit operation of a VHS machine



# 5/VCR

Video Recorder

5/VCR - TR

Troubleshooting and Repair

5/VCR - TR - VP

Video Processing

5/VCR - TR - VP - R

Recording

## 5/VCR - TR - VP

### Video Processing

## 5/VCR - TR - VP - R

### Recording

Most problems in a VCR are mechanical. In most cases, if there is a video problem, replacing the whole circuit board is far easier and less costly than trying to search for the problem on a component level. To even attempt this you will need the service manual for the specific VCR. You will also need the test equipment detailed in Section "5/VCR - TE", including a known, good test tape.

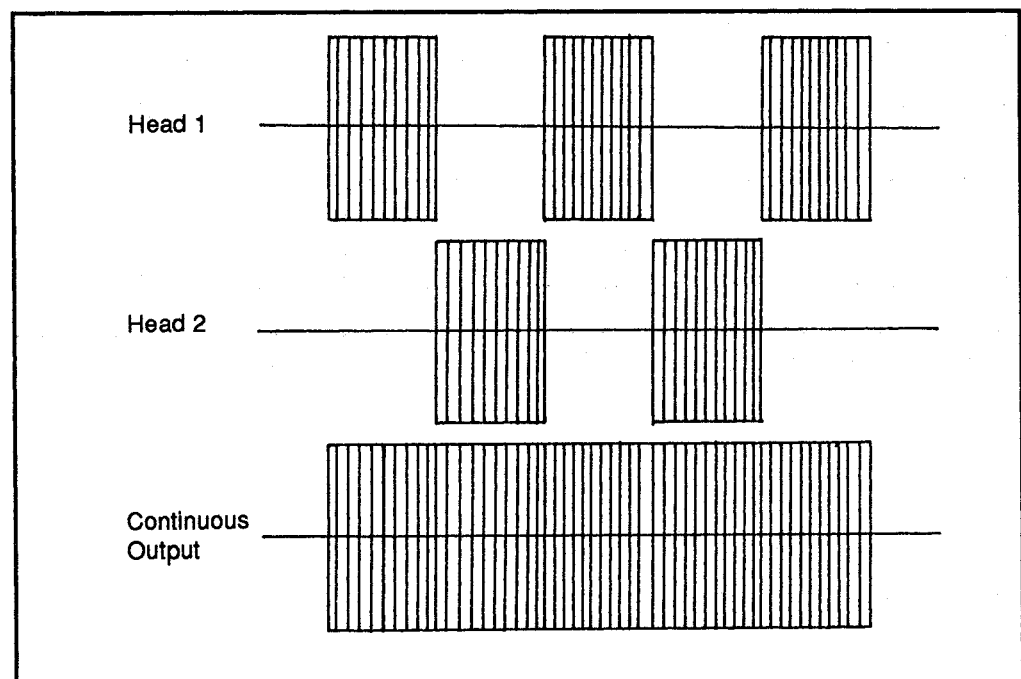


Figure 1: Recording pattern of shifted information

VCRs use high-density recording to get the most program information on a given amount of tape. VHS recorders use a  $\pm 6^\circ$  azimuth difference or a  $12^\circ$  difference between video heads. Azimuth recording and phase inversion are used to cut down on the amount of crosstalk. The chroma (color) of a typical VHS system



5/VCR - TR	Troubleshooting and Repair
5/VCR - TR - VP	Video Processing
5/VCR - TR - VP - R	Recording

is recorded at 629 kHz. This is produced by mixing the incoming 3.58 MHz chroma signal with a 4.2 MHz reference signal and then phase-inverting and locking the incoming horizontal signal. (The 629 kHz is 40 times the horizontal signal at 15,734.26 Hz.)

The signal is placed on videotape via the heads in video head assembly. As the heads spin, the signal is placed on the tape in increments of 90° at each successive horizontal line. After four lines the 629 kHz signal is back to the original phase.

The pattern used in recording the shifted information is shown in Figure 1. When the reference signal of 4.2 MHz is played back, it is phase-inverted and mixed with the 629 kHz signal to restore the original 3.58 MHz chroma signal.

The playback 629 kHz and reference 4.2 MHz signals are phase-shifted in the same direction, mixed, and output as a 3.58 MHz signal at normal phase.

## 5/VCR - VCS

### Various Case Studies

## 5/VCR - VCS - HiVT34A

### Hitachi Model VT-34A

This case study will be on a Hitachi Model VT-34A (Figure 1). This is a somewhat older model, which means that units are beginning to come in for more extensive service. Yet this “workhorse” exhibits circuits and mechanisms that have come to be adopted by many other VCRs.

### Basic Overview

The Hitachi VT-34A is a standard 105 channel cable ready VHS VCR with two video heads, mono audio, and an infrared remote. Full specifications for this model are listed in Table 1. (Note: The channel numbers covered—i.e. 105 channels—refer to the total number of channels the VCR can receive, that is VHF, UHF, and cable channels.)

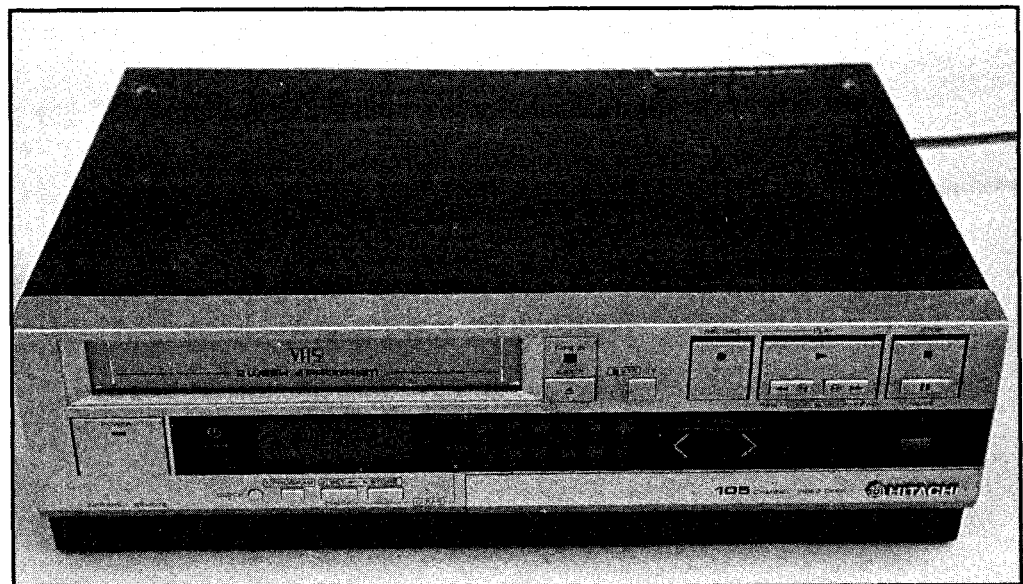


Figure 1: The Hitachi Model VT-34A



5/VCR - VCS	Various Case Studies
5/VCR - VCS - HiVT34A	Hitachi VT-34A

**Table 1  
Specifications**

Video Heads	Two head Helical Scan
Video	NTSC Color EIA Standard, VHS format
Heads	2 video heads for recording/playback in SP/LP/EP 1 stationary head with control track head, audio erase head and audio record/play head
Tape Speed	SP (33.35 mm/s), LP (16.67 mm/s), EP (11.12 mm/s)
Tape Width	12.7 mm
RF Output	TV Channel 3 or Channel 4 (selectable)
RF Input	VHF 75 $\Omega$ , UHF 300 $\Omega$
Channel range	VHF—CH 2 to CH 13, UHF—CH 14 to CH 83, Cable CH A to CH I, and Cable CH J to CH W.
Video Input	0.5-2 V p-p 75 $\Omega$ Unbalanced
Video Output	1 V p-p 75 $\Omega$ Unbalanced
Audio Input	316 mV rms (-7.8 dB) 100 k $\Omega$
Audio Output	316 mV rms (-7.8 dB) 600 $\Omega$
Video Recording S/N	Better than 46 dB (SP), Better than 43 dB (LP), Better than 40 dB (EP)
Power Input	AC 120 V 60 Hz
Power Consumption	39 W Nominal

## Removing or Disassembling of Parts

Before removing any mechanisms from the VCR, you should note the following items.

These parts have been set using precision jigs at the factory and should not be removed without the proper jigs and tools. These parts are:

1. Take-up/supply catchers and fixing screws
2. Inclined guide
3. Supply guide pole height adjusting nuts
4. Take-up/supply guide roller height adjusting screws

# 5/VCR

Video Recorder

5/VCR - VCS

Various Case Studies

5/VCR - VCS - HiVT34A

Hitachi VT-34A

5. AC head X value adjusting screw
6. AC head tilt adjusting screw
7. AC head azimuth adjusting screw
8. AC head height adjusting nut
9. Back tension adjusting spring holder fixing screw
10. Tension band fixing screw

## Tools Needed

The tools to properly adjust and replace these items include a back tension meter, alignment tape (in the correct recorded format, i.e. NTSC, PAL or SECAM), fan type tension gauge, 1.5 mm hexagonal wrench, reel disk height jig, dummy reel, torque gauge adapter, torque gauge and a height reference plate.

## Disassembly

The back of the VCR is shown in Figure 2. We shall begin by disassembly of the unit. Disassembly will allow for easier cleaning and repairing of the unit.

## Cover

The first step is to remove the two top cover screws at the rear top and remove the cover. Lift the rear first, then the entire cover. At this point you will be able to do periodic maintenance on the VCR, like head cleaning and inspection of the video tape tracks.

## Bottom Plate

Next, to remove the bottom plate, turn the VCR upside down and remove the five screws shown in Figure 3. Directly below this panel is the main PC board. Several screws will have to be loosened along the front of the board to allow the board to tilt up so you may access the drive belts and drives that lie below. You are able to inspect and change any drive belts that are worn or broken.

## Front Panel

To remove the front panel, first do the previous steps then remove the channel preset cover. Open the channel preset cover and remove by pulling straight forward.

Loosen the top front screws located on either side of the front panel. Tilt the front panel forward and remove.

To remove the jack panel, do the previous steps first. Release the 2 stoppers and pull the panel forward to remove it. These stoppers are shown in Figure 4.

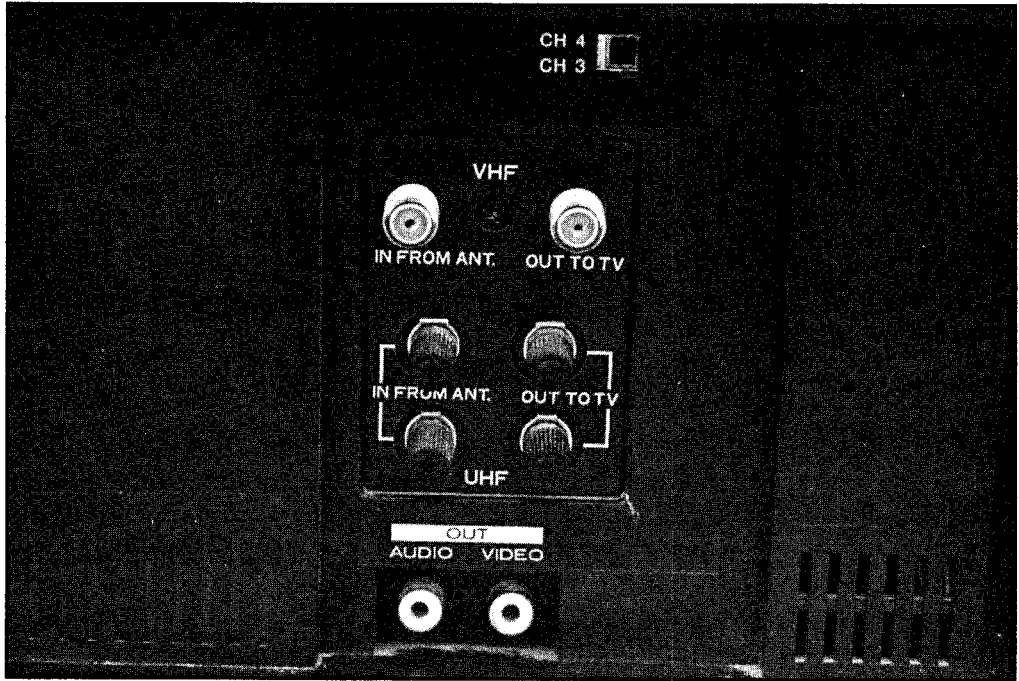


Figure 2: Back view of VT-34A

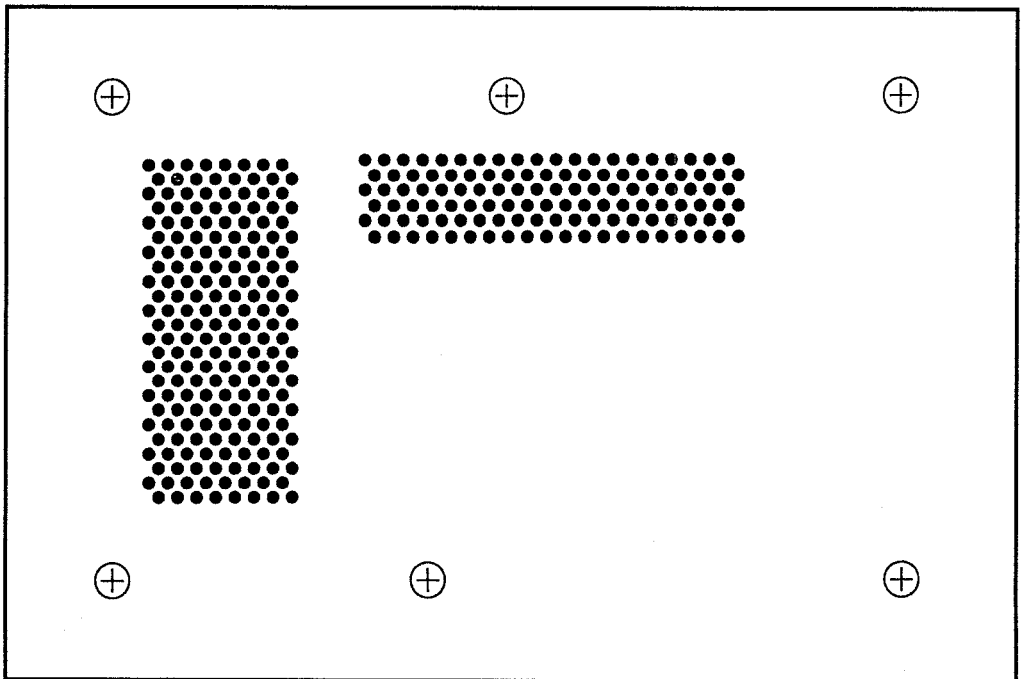


Figure 3: Placement of screws on bottom plate of VCR

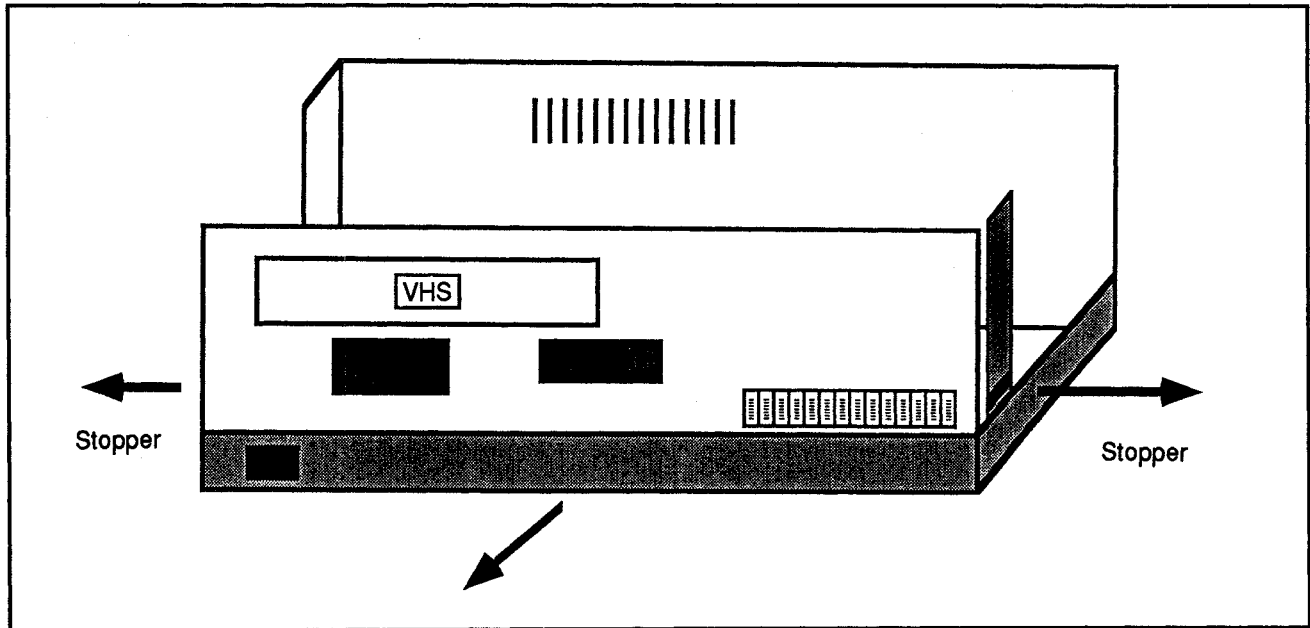


Figure 4: Jack panel removal

### PC Board Removals

To remove any of the PC boards, complete the steps outlined before. Figures 5a and 5b indicate the location of various PC boards.

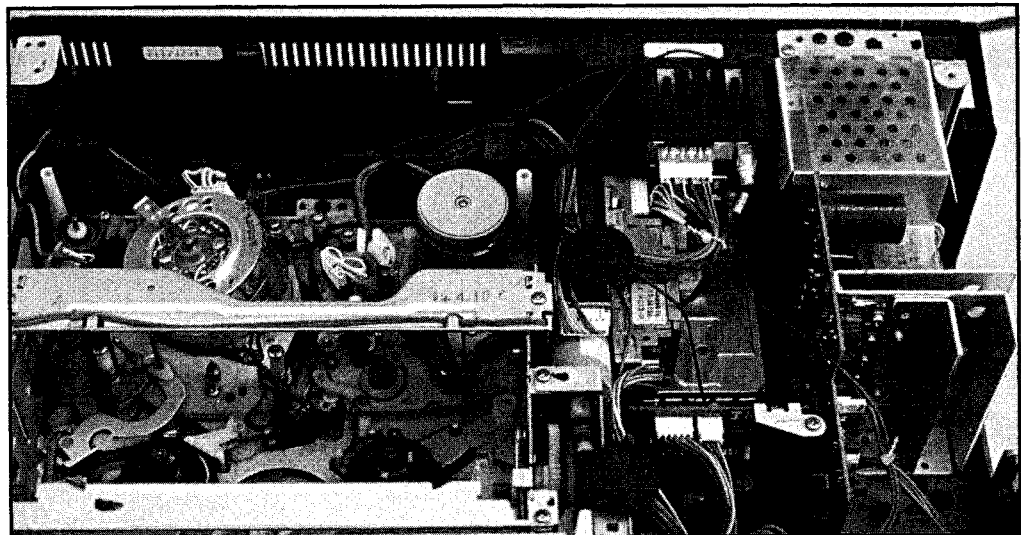
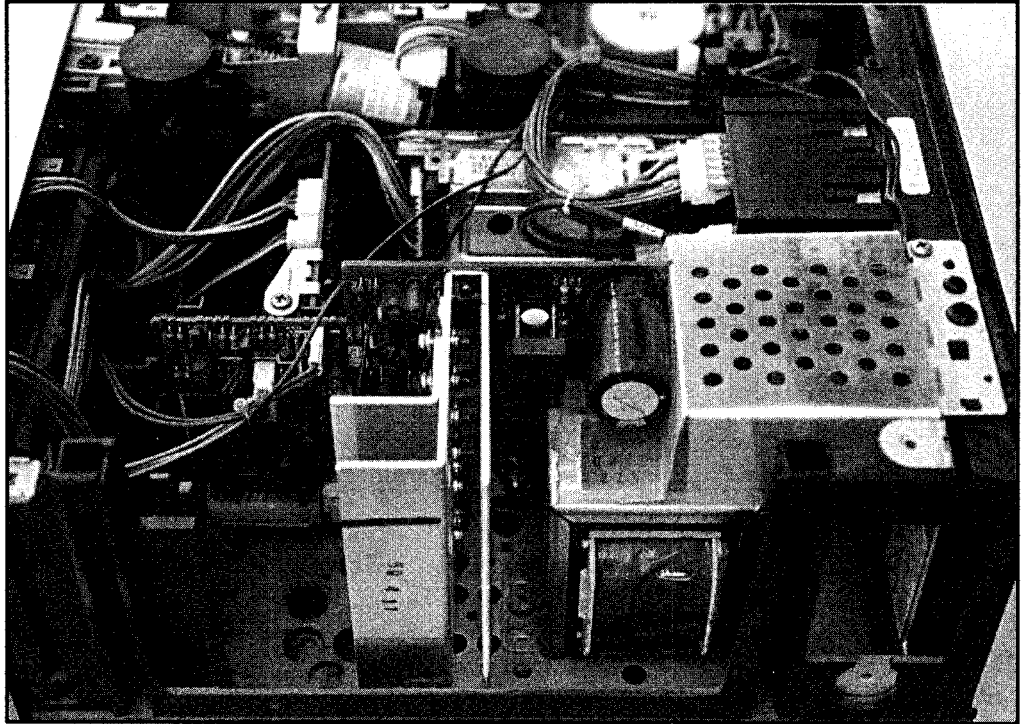


Figure 5a: Location of various PC boards within the VT-34A



**Figure 5b:** Location of various PC boards within the VT-34A

Each of the PC board sections will have screws that must be removed first. Then, stoppers will need to be released to allow removal of the PC board.

As you remove the PC board, disconnect the board connector or connectors. Each of these is color coded and keyed differently so as to avoid accidental misconnections (a feature that may not be true in all VCRs).

### Placement of Parts on the Main Chassis

Figure 6 shows the top view of the main chassis and the placement and names of the parts. Figure 7 shows the bottom view placement and names of parts. Refer to these two drawings and lists when making any adjustments and repairs to the VT-34A.

### Mechanical Adjustments

#### Mechanism State Switch

Located near the supply reel at the bottom of the chassis is the mechanism state switch. To adjust the mechanism state switch:



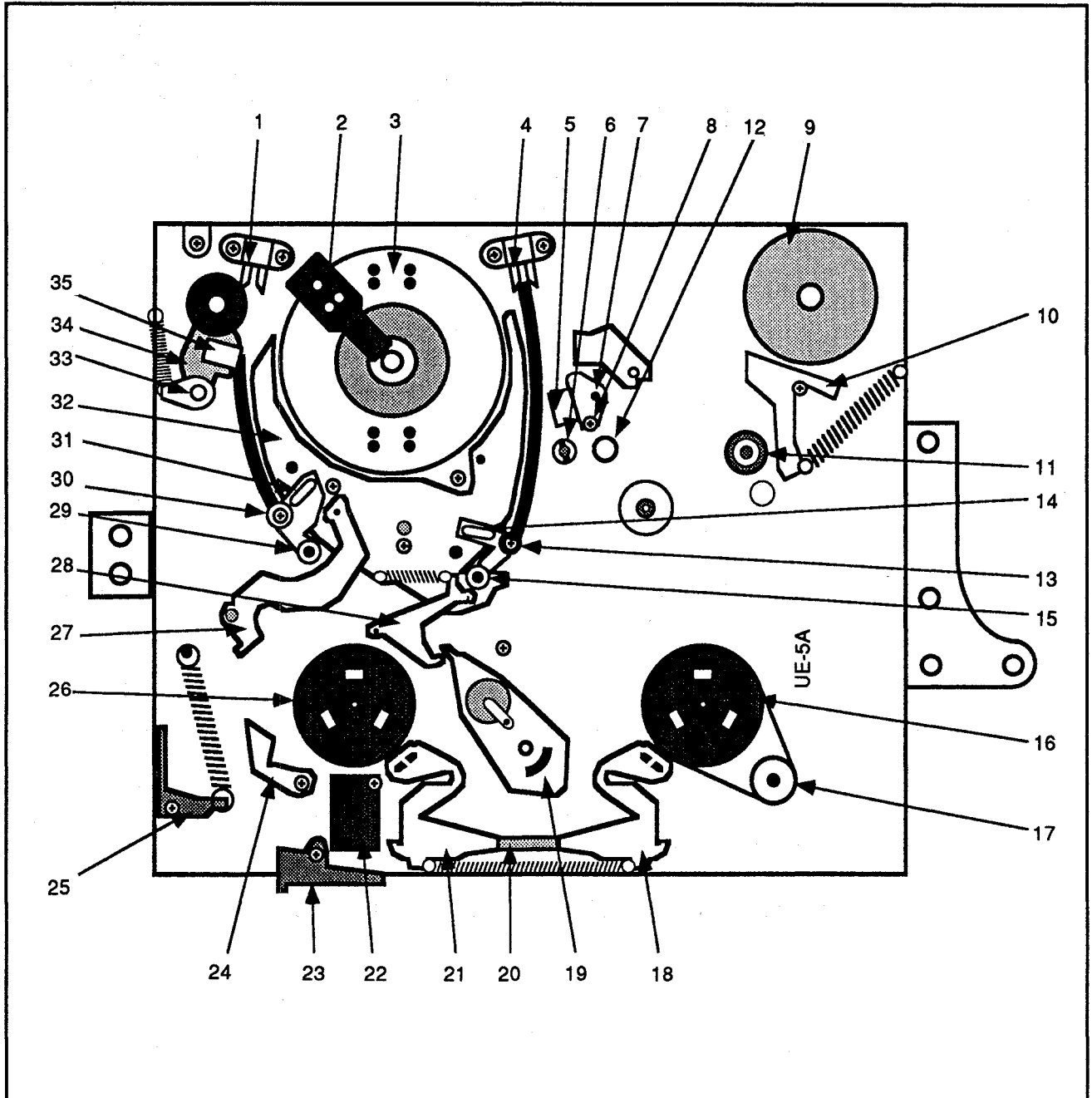
**5/VCR**  
Video Recorder

5/VCR - VCS

5/VCR - VCS - HiVT34A

Various Case Studies

Hitachi VT-34A



**Figure 6:** Top view of main chassis parts

Rotate the worm gear shaft by hand counterclockwise until the loading mechanism is in the unloaded position (until it stops).

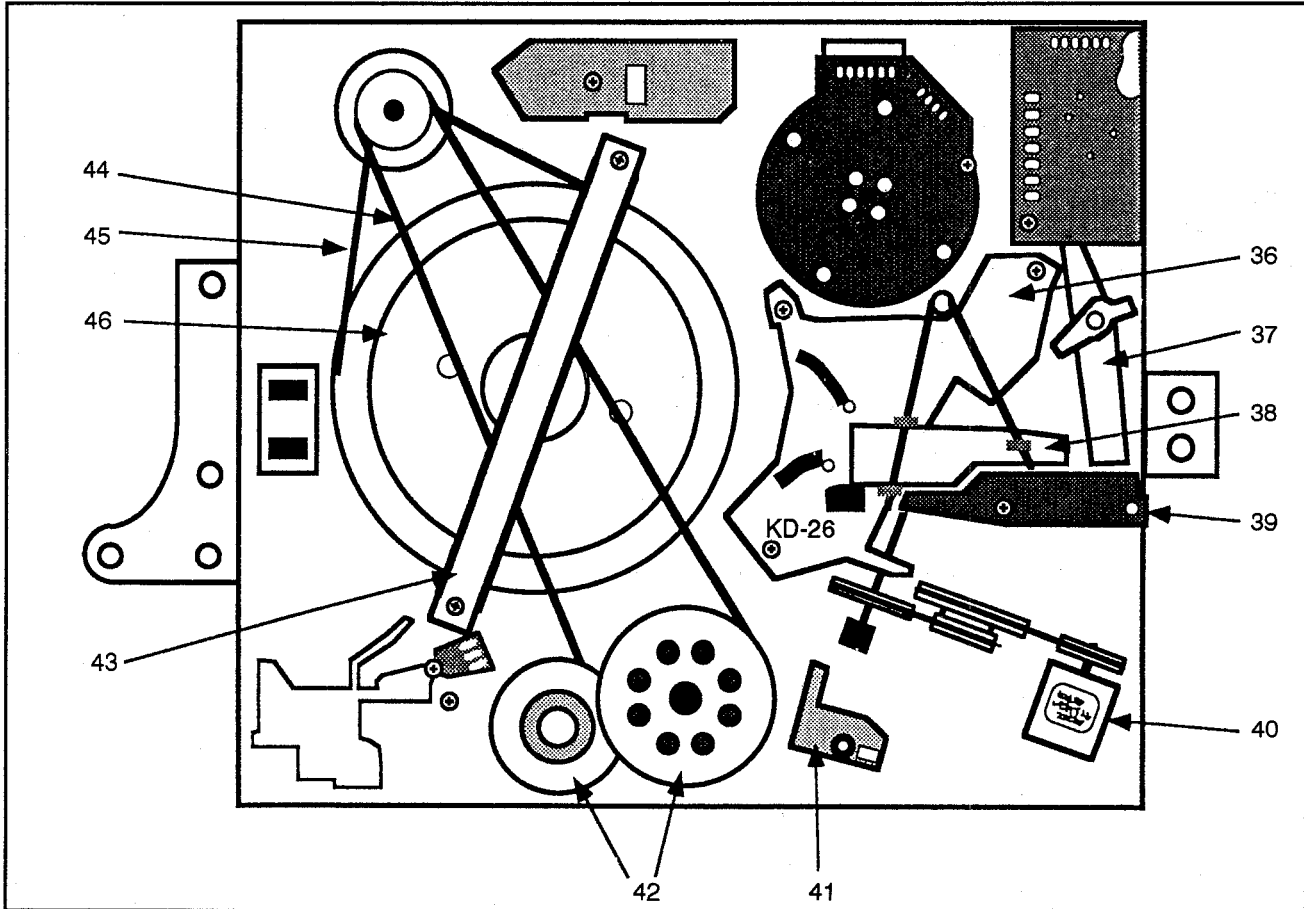


Figure 7: Bottom view of main chassis parts

Table 2 Parts listing

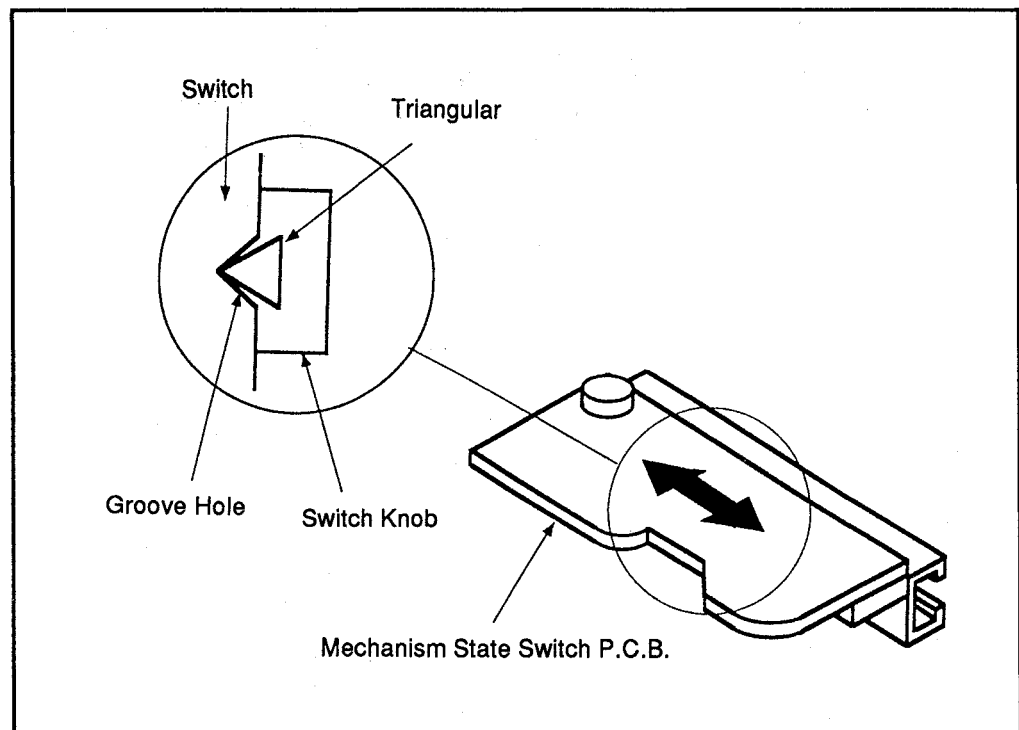
1. Supply catcher	17. Take-up pulley	33. Supply guide pole
2. Cylinder motor brush	18. Take-up main brake	34. Impedance roller arm assembly
3. Upper cylinder of the video head	19. FF/REW idler arm assembly	35. Full erase head
4. Take-up catcher	20. Brake conversion arm	36. Loading gear assembly
5. Audio Control head	21. Supply main brake	37. Tension release arm # 2
6. X value adjusting screw	22. Safety tab switch	38. Mode slider
7. Tilt adjusting screw	23. Record prevention arm	39. Mechanism state switch
8. Azimuth adjusting screw	24. Tension band assembly	40. Loading motor assembly
9. Capstan motor assembly	25. Spring holder	41. Brake slider assembly
10. Arm bracket assembly	26. Supply reel disk	42. Clutch plate assembly
11. Pressure roller assembly	27. Tension arm	43. Flywheel support plate
12. Tape guide pole	28. Sub-brake	44. Reel belt
13. Take-up guide roller	29. Supply guide roller base	45. Flywheel belt
14. Take-up Inclined guide	30. Supply guide roller	46. Flywheel assembly
15. Take-up guide roller base	31. Supply inclined guide	
16. Take-up reel disk	32. Guide base clamp plate	

Loosen the mechanism state switch fixing screw and match the top of the triangular hole in the knob of the mechanism state switch with the point of the triangle groove hole. This is illustrated in Figure 8. Tighten the mechanism state switch fixing screw. Load a tape and test different modes. If any of the modes is faulty, realign the mechanism state switch.

### Tape Transport System

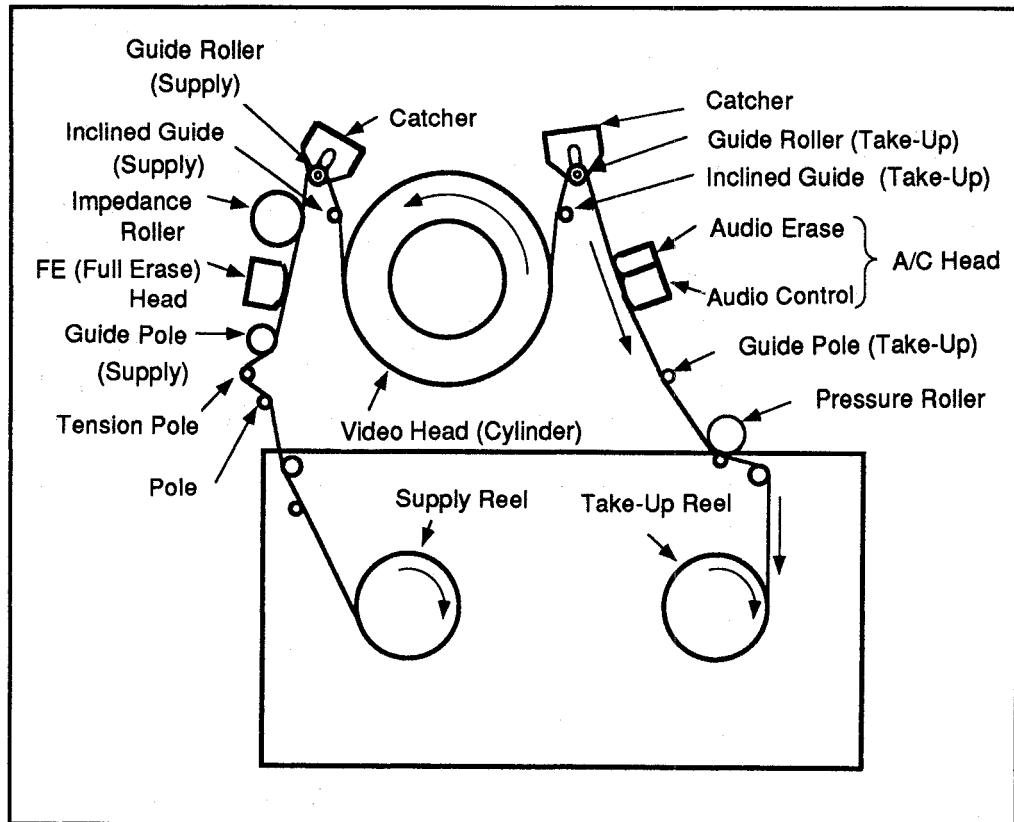
Figure 9 shows the complete tape transport system. Many of the transport items shown will require adjustments and these are:

- Reel disk height adjustment
- Tension pole adjustment
- Guide post height adjustment
- Audio/Control head adjustment
- Guide roller height adjustment



**Figure 8:** Alignment of the mechanism state switch

The tape transport system is basically the most important part of the tape control system. It pulls the tape from the supply reel in the cassette, routes the tape around the various tension guides, rollers and guide poles, past the audio and video heads



**Figure 9:** Complete tape transport system

and returns the tape to the cassette's take-up reel. The tape transport is precisely adjusted at the factory and only those parts that are replaced should be adjusted, and then with the proper tools. Occasionally, some of the parts may get out of alignment and require readjustment, but as the old adage goes, "If it isn't broken, don't fix it."

There are two parts that should not have the fixing screws loosened. These parts are the catcher on the supply or take-up side, and the inclined guide on the supply or take-up side.

### Reel Disk Height Adjustment

To adjust/align the reel disk height, a master plane and reel height adjusting jig (from the manufacturer) will be required. The top panel and cassette holder will need to be removed to do the alignment.

Position the master plane in place and place the reel height adjusting jig on the master plane as shown in Figure 10. The reel disk should enter between the A and

### Tension Pole Adjustment

the B side of the reel height adjusting jig. If not, the quantity of the spacers will need to be adjusted (using the 0.25 mm and 0.5 mm types).

This adjustment requires the use of the back tension meter. The cassette panel must be removed and the VCR positioned horizontally. (To replace the tension arm, remove the cassette panel, cassette holder and tension band.) Cover the supply end sensor (or disconnect it) and press PLAY on the VCR without a tape loaded.

Check the gap between the tension pole and the chassis. It should be set to 1.5 mm  $\pm$  0.5 mm. If the gap is incorrect, loosen the tension band fixing screw, insert a flat head screwdriver into the groove in the loading motor holder and the groove in the

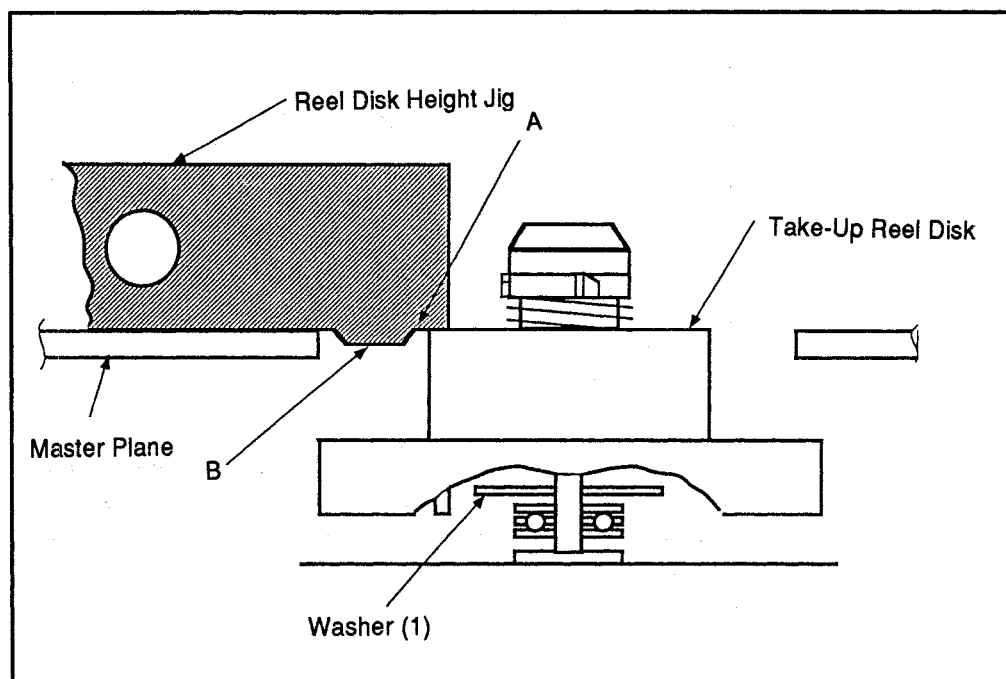
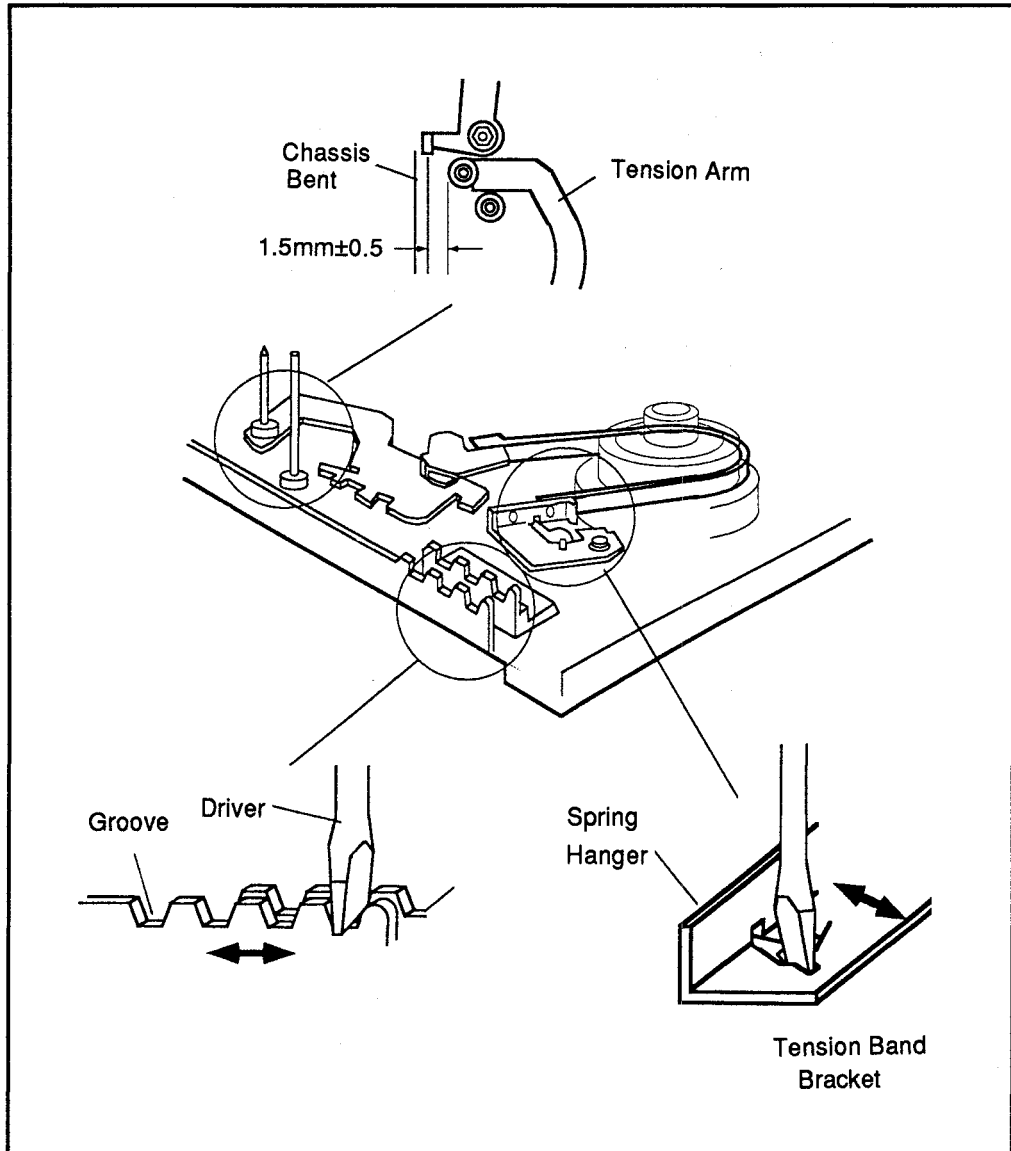


Figure 10: Reel disk height adjustment

tension band bracket. The tension band bracket can be moved by turning the screwdriver. Tighten the tension band fixing screw after the adjustment has been finished and apply some locking paint. The alignment section is shown in Figure 11.

Mount the back tension meter and set the VCR to the Play mode. Check the reading of the back tension meters to see that it is 35 g/cm  $\pm$  8 g/cm. If this is not the case, loosen the spring hanger fixing screw and insert the tip of a flat



**Figure 11:** Tension pole adjustment

head screwdriver into the groove in the chassis and the groove in the spring hanger. Move the tension hanger installation position while turning the screwdriver to adjust so the back tension is  $35 \pm 2\text{g/cm}$  (adjustment value varies from the previous check).

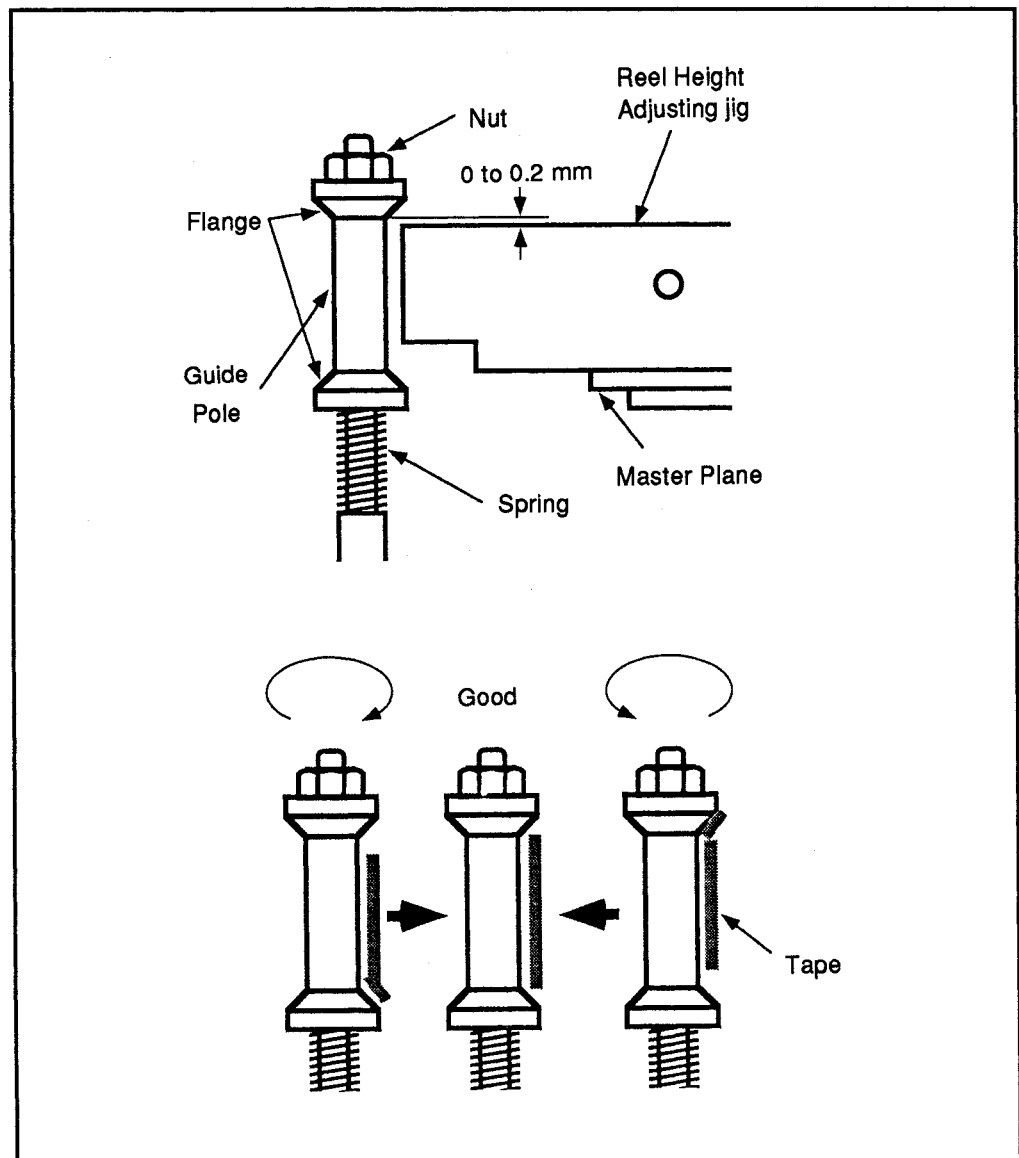
Tighten the tension hanger fixing screw and apply some locking paint after complete adjustment.

**Guide Post  
 Height Adjustment**

The guide post adjustment requires the master plane, reel height adjusting jig, and a blank tape. Figure 12 shows the adjustment.

Rough adjustments can be made using the master plane and reel height adjustment jig. A tape will be required to finish the precise adjustment, afterwards.

The top panel of the VCR and the cassette holder will need to be removed. Mount



**Figure 12:** Guide post height adjustment



5/VCR - VCS

Various Case Studies

5/VCR - VCS - HiVT34A

Hitachi VT-34A

the master plane and place the reel height adjustment jig on the master plane. Adjust the guide post by turning the nut until the gap between the flange of the guide pole and the reel height adjusting jig is within 0-0.2 mm when the side of the jig is placed next to the guide post.

Install the cassette holder, load a tape and play it. Inspect the tape as it transverses the guide post to ensure it is not riding over the post. If the tape rides over the guide post, adjust the nut until the tape no longer runs over the flange of the guide post. Apply some locking paint to the nut to secure it.

### Audio and Control Head Adjustment

The audio/control head (AC head) adjustment requires the use of the master plane, reel height adjusting jig, and a blank tape. The AC head adjustment consists of the audio play output/recording bias level (described later) and the height/azimuth/tilt adjustment following. All of these adjustments will be required when replacing the assembly. Figure 13 shows the area of adjustment.

Begin by tightening the screw (35) located at the bottom of the head base so that it projects about 1 mm above the top of the AC head base. Then roughly adjust the tilt adjusting screw (37) and the azimuth adjusting screw (36) so that the gap between the AC head base and the head base is about 2.3 mm, and the AC head base and head base are parallel.

Remove the cassette holder and position the master plane as shown in Figure 14. The AC head height adjusting nut can be roughly adjusted now, so that the gap between the reel height adjusting jig and the shield case of the AC head is about 0.5 mm when the side of the jig is positioned next to the AC head.

Next install the cassette holder, load a blank tape and press Play. Check to see that there is no conspicuous curling or protruding around the AC head. The proper positioning of the video tape occurs when the bottom of the tape is about 0.3 mm from the bottom of the core of the control head.

The tilt adjusting screw, azimuth adjusting screw and the AC head height adjusting nut can be roughly adjusted if there is any conspicuous curling or protruding occurring.

Precise adjustment requires the use of an oscilloscope hooked to the audio out connector. The alignment tape will need to be played at the 7 kHz section of the tape. Adjust the tilt adjusting screw, azimuth adjusting screw and AC head height nut alternately so the audio output is maximized, the envelope is flat and stable as shown in Figure 15.





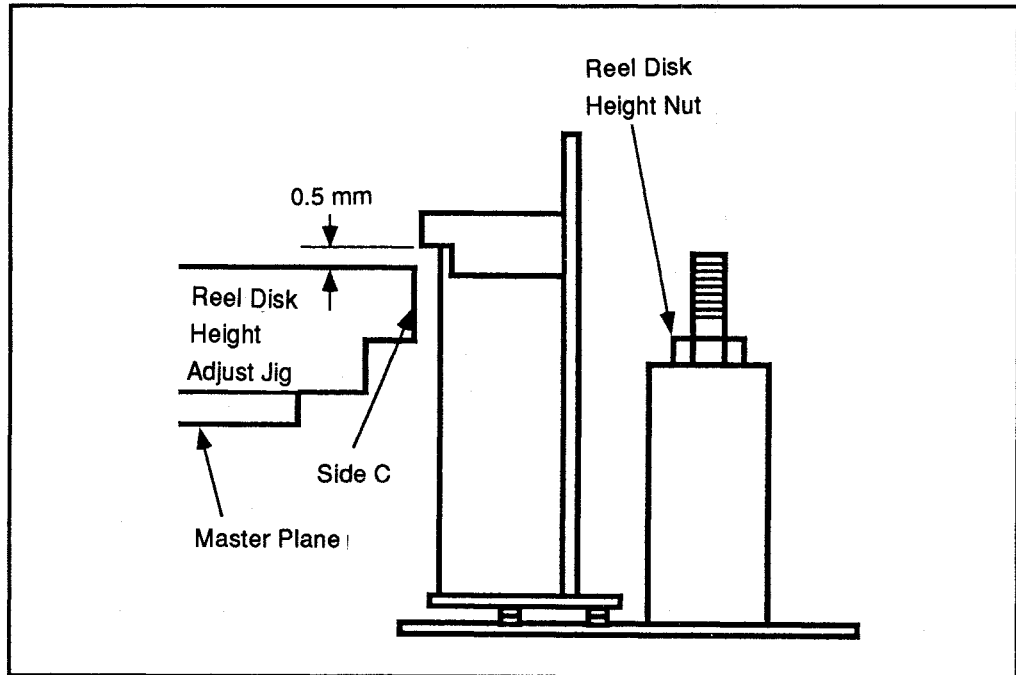


Figure 14: Master plane placement for AC head adjustment

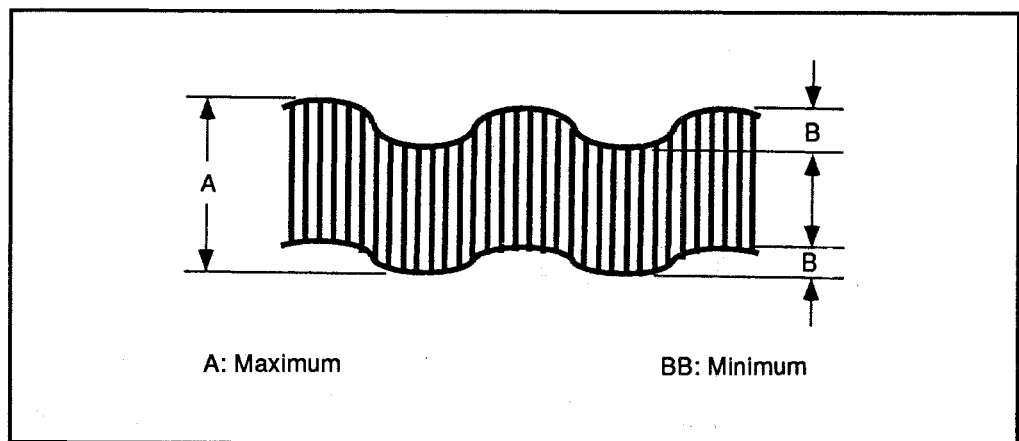
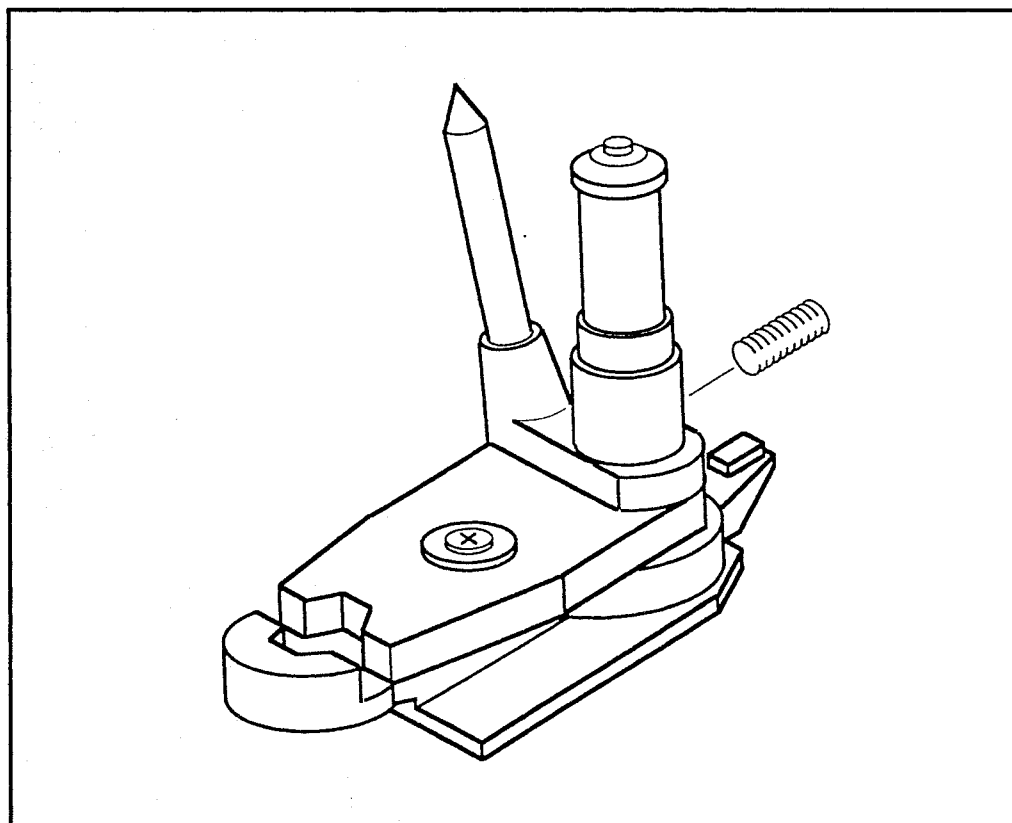


Figure 15: Waveform for proper adjustments of AC assembly

Check for any conspicuous curling, protruding or lifting around the tape guide of the lower cylinder. If any occurs, stop the tape and check the back tension. Then loosen the guide roller fixing screw shown in Figure 16. This screw allows for rough adjustment of the guide roller height during tape playback.

Connect an oscilloscope to the FM output terminal (TP202). Insert and play the

alignment tape and adjust the tracking variable resistor at the front of the VCR so that the FM signal output is maximized. Turn the tracking variable resistor in either direction so the FM signal output is at 75% of the maximum value after adjustment.

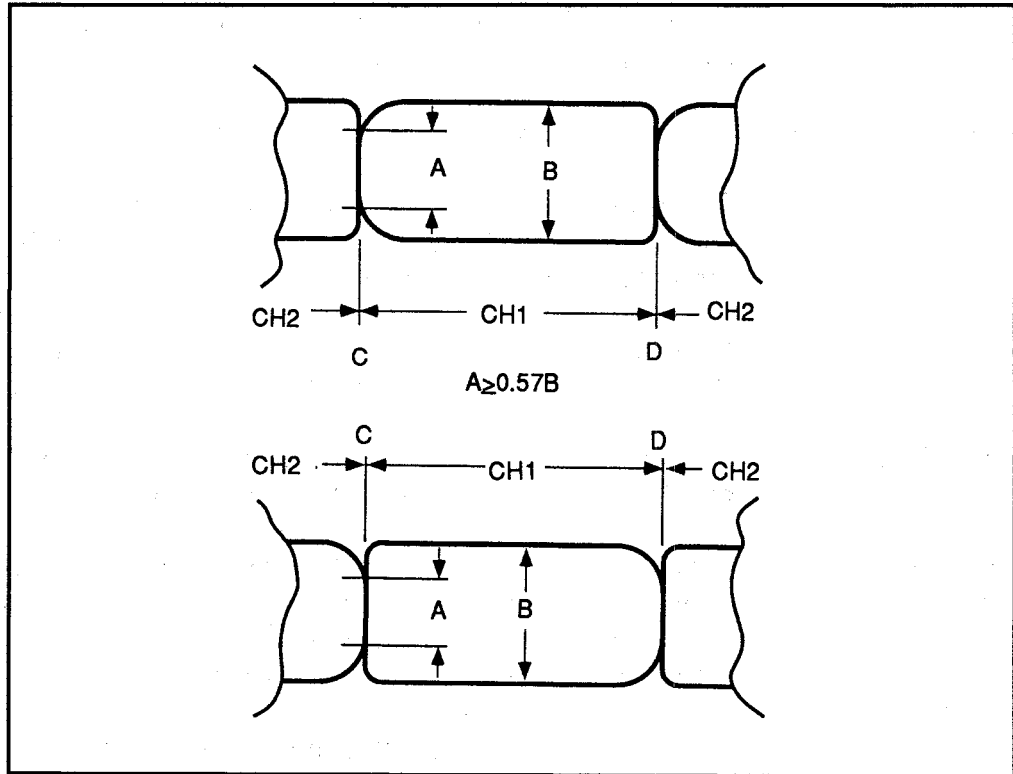


**Figure 16:** Guide roller

Check the FM signal envelope. There should not be conspicuous fluctuations and the ratio between the maximum section and the minimum section should not be more than 57%. Figure 17 shows two waveforms used for this comparison.

The use of a prerecorded tape (that can be damaged) should be used. Recorded color bar signals, or other signals, are all that are required. These should play for over 2 minutes in the SP mode.

Play the recorded tape and adjust the take-up guide roller or the supply guide roller as discussed. The guide roller should not be turned more than one turn at a time. Check to see that the FM signal envelope is within the specifications



**Figure 17:** Comparison wave forms: (a) adjust the supply guide roller when outside of specifications (b) adjust the take-up guide roller when outside of specifications

described above. Tighten the guide roller fixing screw after completing the adjustment.

## Electrical Circuit Adjustments

### Alignment

### Equipment Needed

- Color TV set
- Oscilloscope
- DMM
- VTVM
- Pattern generator
- Frequency counter
- Alignment tape
- Blank tape

The first section that must be checked for proper operation of any part of the VCR is the power supply and regulator circuit. The output of this section is fed

# 5/VCR

Video Recorder

5/VCR - VCS

Various Case Studies

5/VCR - VCS - HiVT34A

Hitachi VT-34A

to the main PC board sections which include the servo circuits, Y/C circuits, and the audio circuits.

**Power Adjustment** To access the power section, remove the top cover and set the VCR horizontally.

Connect a voltmeter (DMM) to the test point terminal PG601-7. The adjustment pot RT101 should be adjusted to provide a reading of  $9.5\text{ V} \pm 0.1\text{ V}$ . Figure 18 shows the location of this pot.

If the adjustment cannot be properly made, check the incoming power and the related power board circuits. Replace any faulty components before continuing.

**Servo Circuit** The servo control circuit allows for adjustment to the cylinder speed and capstan speed. The cylinder speed must be set to a constant speed of 1800 RPM.

**Cylinder Speed Adjustment** Connect the pattern generator (color bar signal) to the video input jack on the front panel, or tune in a TV program. Connect the oscilloscope between the test point terminals PG601-3 and ground. Make sure the recording speed switch is set to "SP" and place the VCR in the record mode.

Short circuit the test points PG601-2 and PG601-7. Adjust RT607 so the sampling pulse superimposed on the cylinder tach pulse does not move. This is shown in Figure 19.

Disconnect the short circuit between PG601-2 and PG601-7. Check to see that

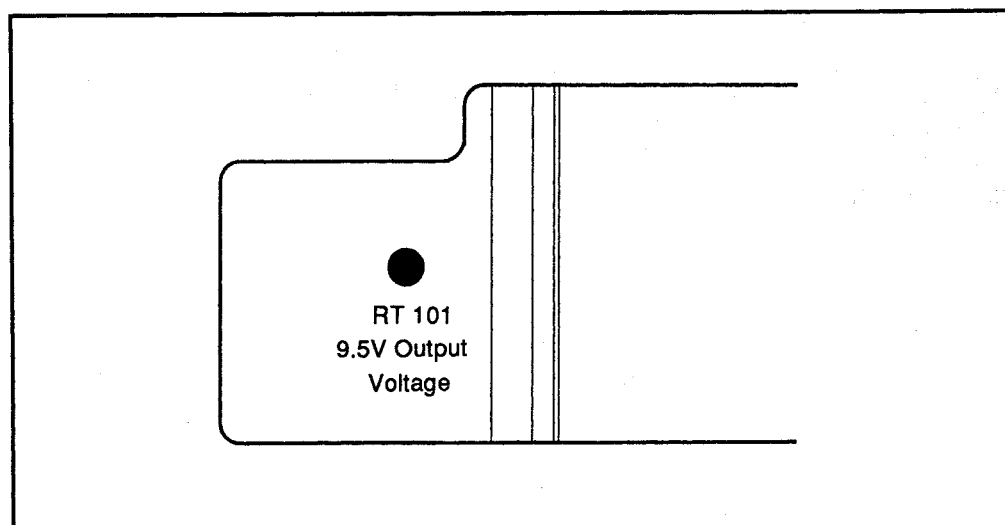


Figure 18: Power supply board as seen from the parts side

the sampling pulse stands still at the trailing edge of the cylinder tach pulse. This is shown in Figure 20. This completes the cylinder speed adjustment.

### Capstan Speed Adjustment

The next servo adjustment is the capstan speed adjustment. This adjustment sets the tape speed to a constant speed of 33.35 mm/s in SP, 16.67 mm/s in LP and 11.12 mm/s in EP.

Connect an input signal to the VCR either from the pattern generator or a TV signal. Connect the oscilloscope between the test point terminals PG601-6 and ground.

Set the tracking adjustment on the front panel to the center (click position) and

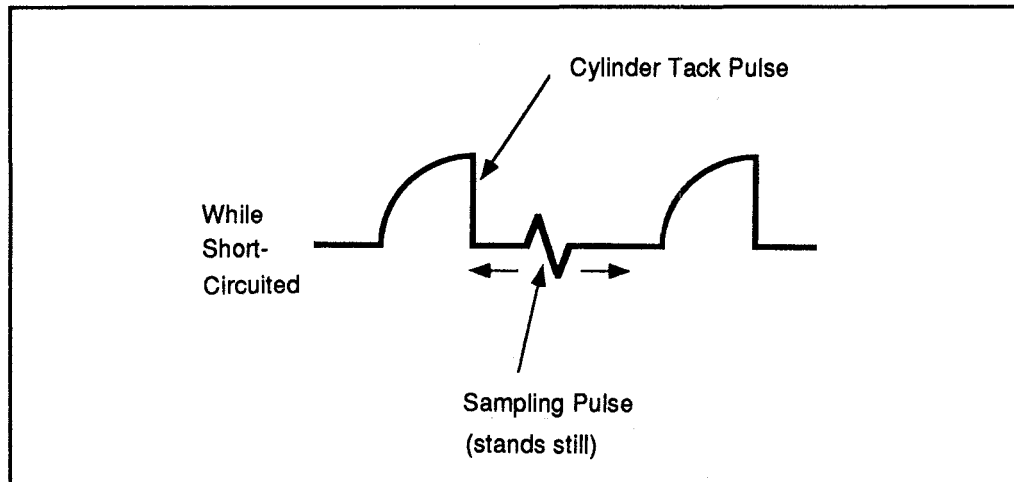


Figure 19: Cylinder tach pulse and sampling pulse

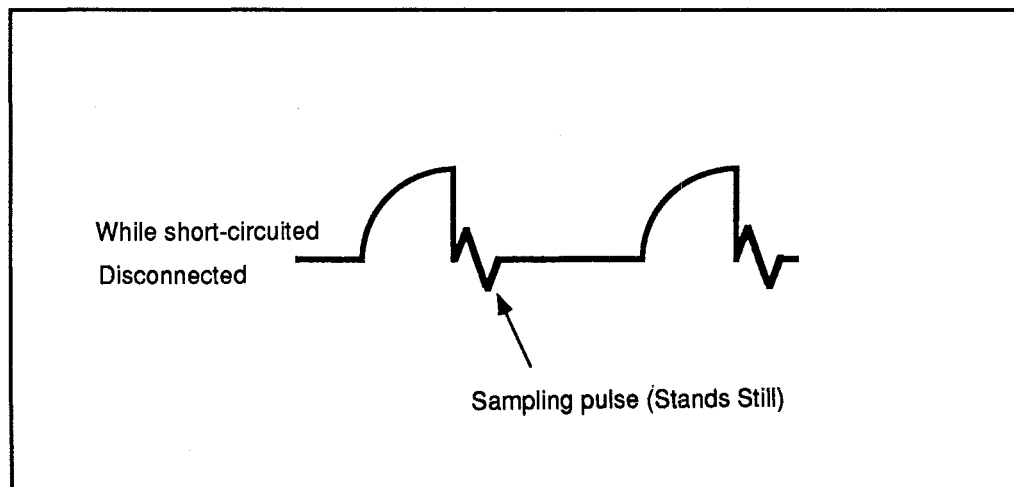


Figure 20: Cylinder tach pulse and sampling pulse after short circuit removed

the recording speed to EP. Insert a blank tape and press record.

Short circuit the test points PG601-2 and PG601-7. Adjust RT608 so that the sampling pulse is superimposed on the tracking MM charge curve. The signal should stand still as shown in Figure 21.

Disconnect the short circuit from PG601-2 and PG601-7 and check to see if the tracking pulse stands still in the leading edge of the tracking MM charge curve. This is shown in Figure 22.

The capstan speed adjustment is not required for all three modes (SP, LP, and EP). The performance of these modes can be checked by doing as instructed before and recording in the different modes. The sampling pulse shown in Figure 22 should not change.

### Reference Oscillation Speed Adjustment

The frequency counter will need to be connected to the audio output jack on

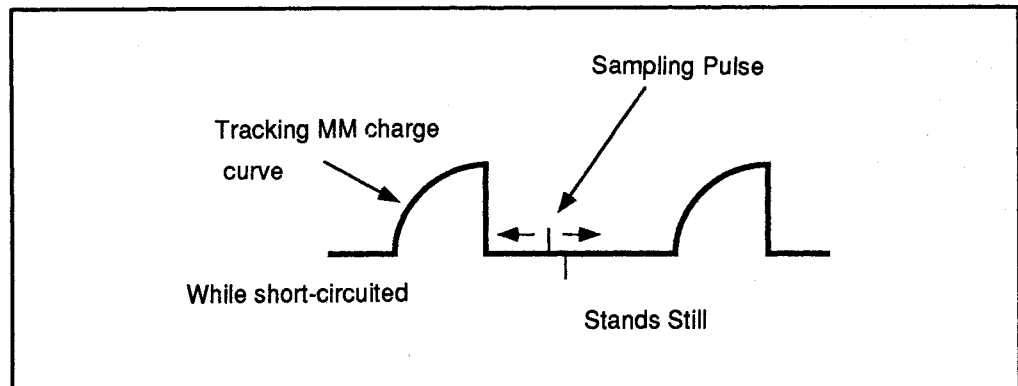


Figure 21: Capstan waveform adjustment

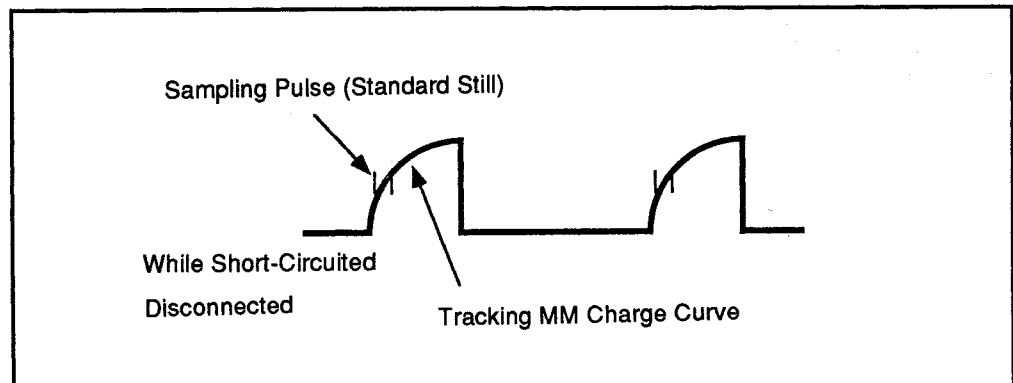


Figure 22: Capstan waveform adjustment without circuit shorted

the rear of the VCR. Short circuit the test points PG601-7 and PG601-8. Play the 3 kHz audio track section of the alignment tape. The frequency counter reading should be 3000 Hz  $\pm$ 15 Hz. If the reading is 3015 Hz or more, adjust R615. If the reading is 2985 Hz or less, adjust R616.

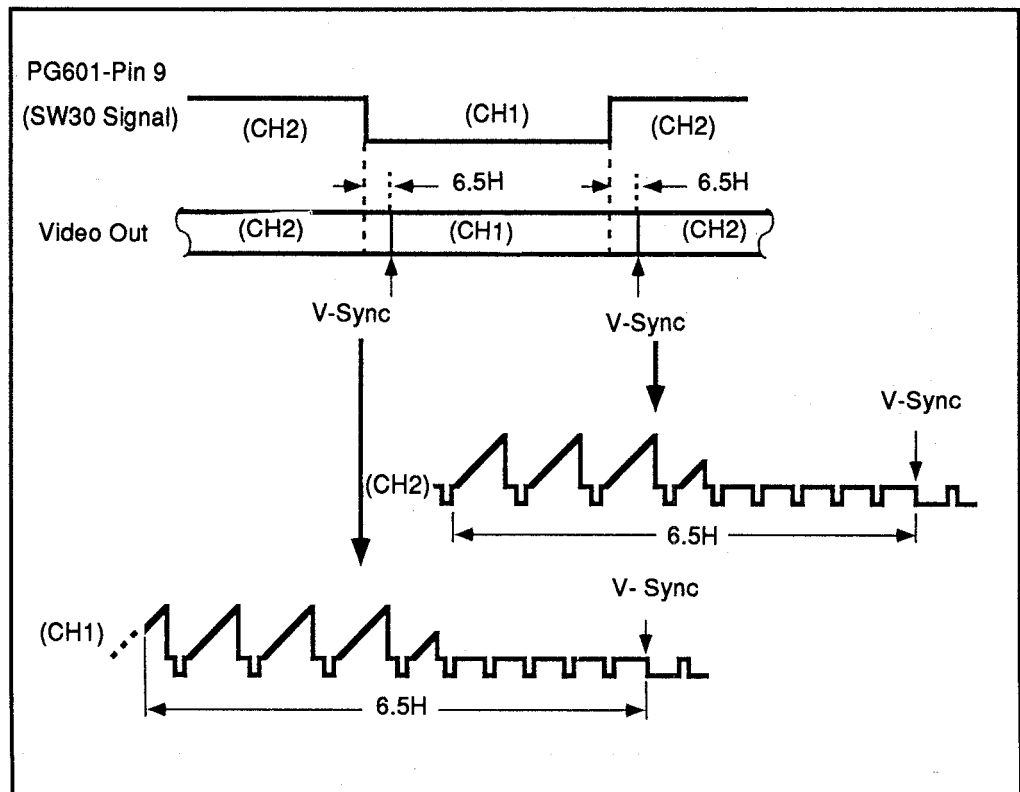
### CH1/CH2 Phase Adjustment

The external trigger of the oscilloscope should be connected to the SW30 signal output, test point PG601-9 and ground. The input of the scope should be connected to the video out of the VCR. Connect a TV to the VHF output to view a picture.

Play the alignment tape. The sync slope select switch of the scope should be set to negative when adjusting the phase of CH1 and to positive when adjusting the phase of CH2. Adjust RT604 and RT603 so that the switching points of the respective channels are 6.5 H  $\pm$ 0.5H before the vertical sync signal in the video signal. The related waveforms are shown in Figure 23.

### Tracking Preset Adjustment

Use either a pattern generator or TV signal for the tracking preset adjustment. Connect channel one of the oscilloscope to the video output jack and channel two to TP614.



**Figure 23:** Waveforms for the channel 1 and channel 2 phase adjustments



# 5/VCR

Video Recorder

5/VCR - VCS

Various Case Studies

5/VCR - VCS - HiVT34A

Hitachi VT-34A

Set the tracking control to the center (click point) and the recording speed select switch to SP. Record for several minutes and then play back this section for adjustment.

The sync slope select switch of the scope should be set to the positive position and then apply the trigger pulse to the CH2 terminal of the scope.

Adjust RT601 so the vertical sync signal in the video signal and the positive half peak of the control pulse match. This is shown in Figure 24.

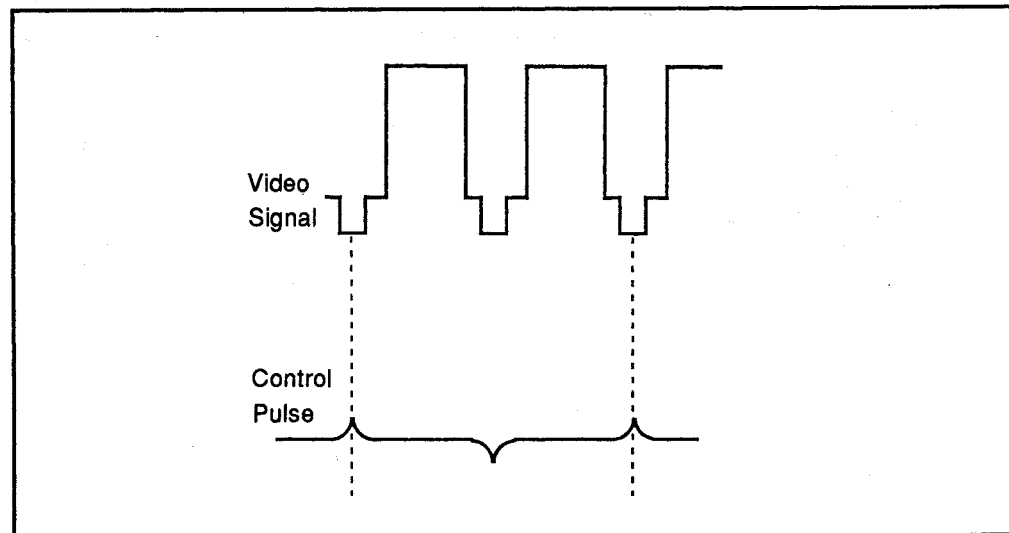
Observe the picture on the monitor and move the tracking control to the left and right to insure the best S/N ratio occurs at the center click position.

## Y/C Circuit

The record Y/C level is set to the adjusted value shown in Table 3. The table refers to the number marked on the upper drum cylinder of the VCR. If the cylinder or parts in the Y/C circuit are replaced, refer to the cylinder number before making adjustments. Compare to Table 3 for proper chroma level settings. The Y level will be 150 mV p-p.

**Table 3**  
Record Chroma  
Levels

Cylinder Marking	Level
No mark	35 mV p-p
1	40 mV p-p
2	40 mV p-p
3	40 mV p-p
4	45 mV p-p



**Figure 24:** Tracking preset adjustment waveform

# 5/VCR

Video Recorder

5/VCR - VCS

Various Case Studies

5/VCR - VCS - HiVT34A

Hitachi VT-34A

Ensure that there is a signal present from the tuner or from a pattern generator. Connect the oscilloscope to test point TP204. Set the VCR record select switch to EP and place the VCR in the record mode.

Turn RT201 fully counter-clockwise and then adjust RT202 so the reading of the scope is equivalent to the value from the table. Next adjust RT210 so the reading is 150 mV p-p on the scope.

### Audio Circuit Playback Level Adjustment

The audio output circuit adjustment will require the use of a VTVM. Connect the VTVM to the audio output. Play the 1 kHz section of the alignment tape. Adjust RT401 so the reading on the VTVM is -8 dBm.

### Audio Circuit Record Bias Level Adjustment

Connect the VTVM to the test point terminal TP401. Set the recording speed to the SP mode and record with no signal coming in. Adjust RT404 so the reading on the VTVM is 2.2 mV  $\pm$  1 mV.

### Tuner/IF Circuit

The tuner and IF section is a single PC board. It has been carefully adjusted and should not require any adjustments. If, however, the section does get out of adjustment, the following may help in readjusting it.

To adjust the carrier filter, connect the sweep marker generator to IC801 pin 6 of the Tuner/OF board by using the coupling circuit shown in Figure 25. The sweep marker output should be  $-30 \pm 10$  dBm, and a marker frequency of 45.75 MHz.

Place the VCR in the Stop mode. Provide +8.5 V DC to IC801 pin 12. Connect the oscilloscope to IC801 pin 6 and view the IF signal waveform. Adjust the core of L805 so that the 45.75 MHz, 50 kHz component of the waveform of the video output is maximized as shown in Figure 26.

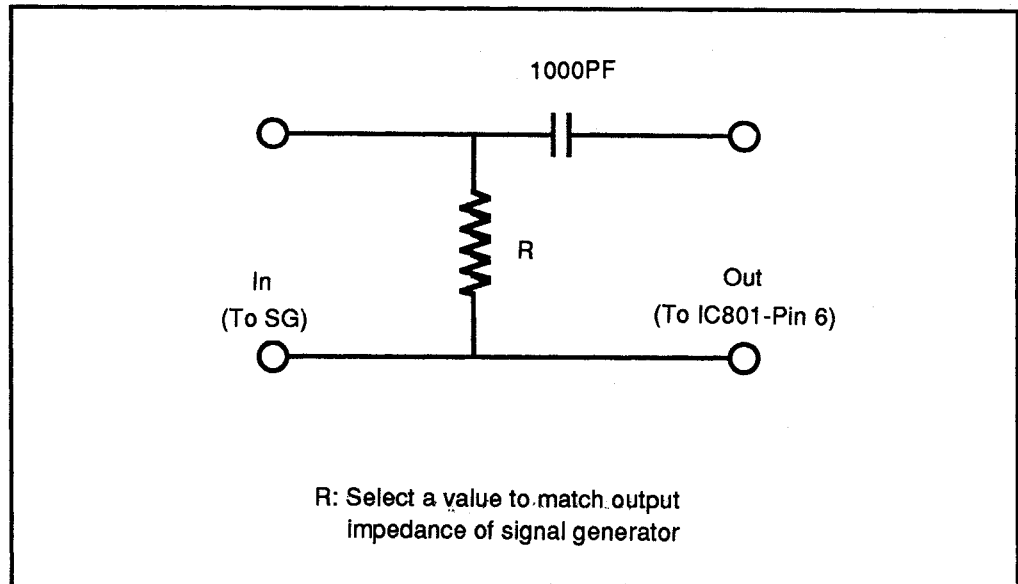
### 4.5 MHz Trap Adjustment

The sweep marker generator will need to be connected to IC801 pin 6 of the tuner/IF board using the coupling circuit shown in Figure 27. Connect the scope to pin 2 of PG751 and +8.5 VDC to IC801 pin 12. The VCR should be in the STOP mode.

Adjust the core of L804 so the level of the audio trap frequency is minimized. This waveform is shown in Figure 28.

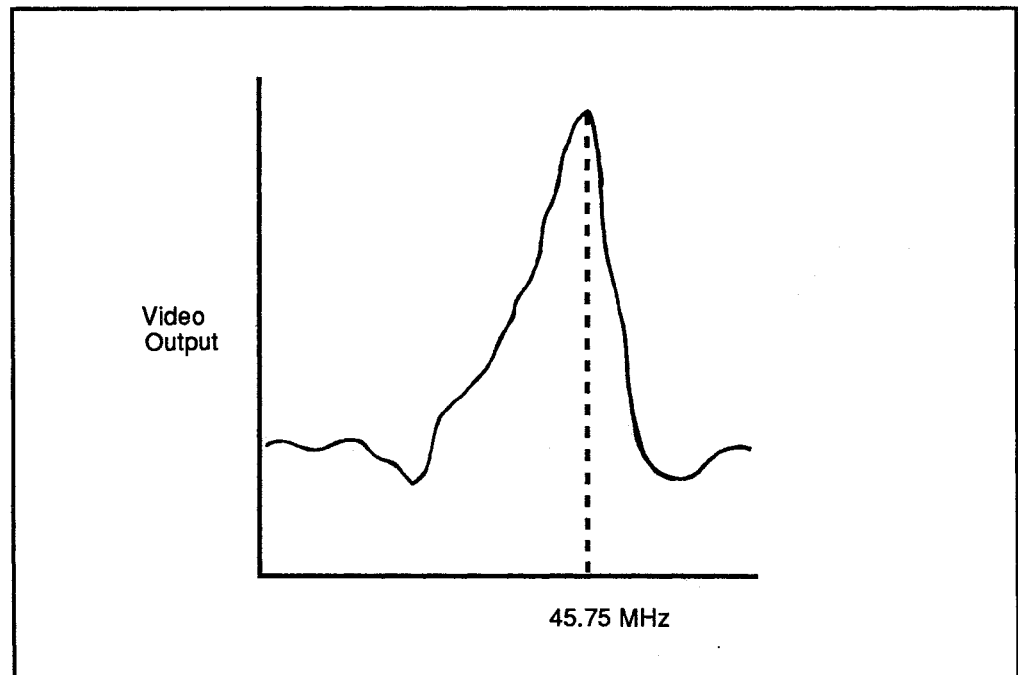
### AFS Adjustment

The sweep marker generator is connected to the tuner pack pin 9 by using the coupling circuit shown in Figure 25 and set to  $-4 \pm 5$  dBm, and a marker frequency of 45.75 MHz.



**Figure 25:** Coupling circuit for carrier filter adjustment

With the VCR in the Stop mode, connect the scope to pin 1 of PG752 by using the coupling circuit shown in Figure 27. Adjust L806 so the output voltage at 45.75 MHz is 6.5 V  $\pm$ 1.0 V as shown in Figure 29.



**Figure 26:** Carrier filter waveform

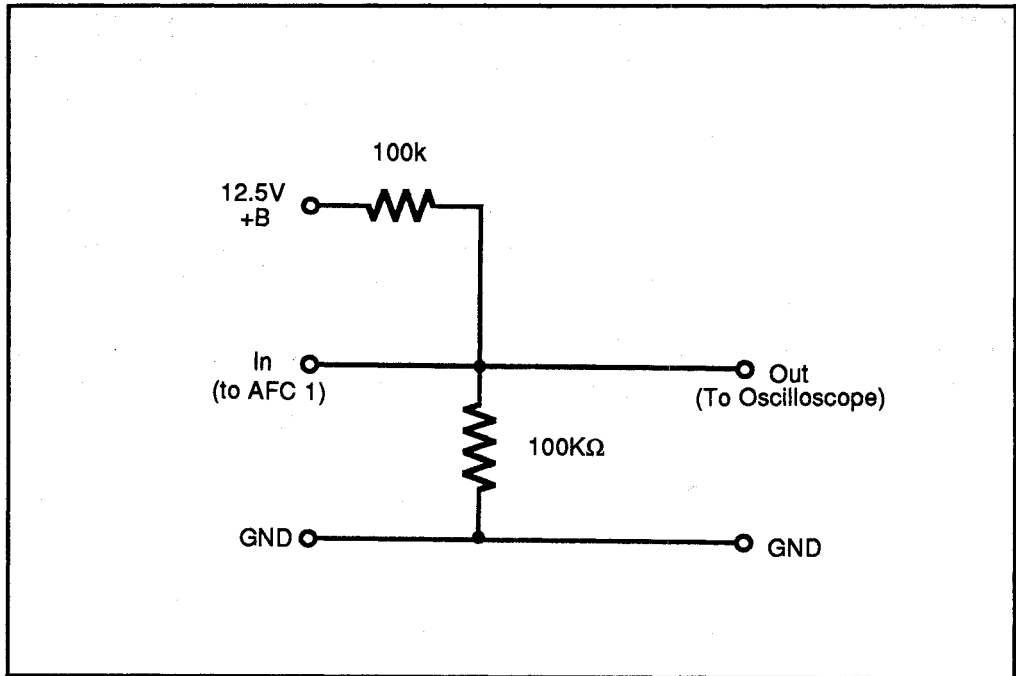


Figure 27: Coupling circuit for 4.5 MHz trap adjustment

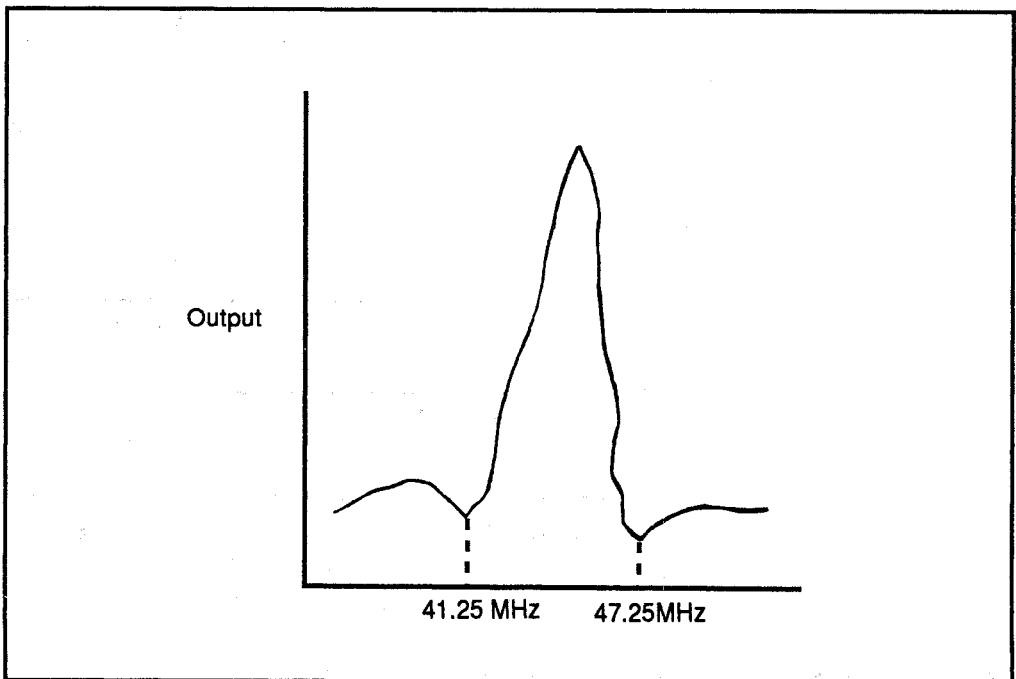


Figure 28: 4.5 MHz trap waveform

**SIF Adjustment**

Connect the AM signal generator to pin 2 of IC801 of the IF pack using the coupling circuit shown in Figure 25. The AM signal generator should be set to 41.25 MHz  $\pm$ 5 kHz, -60 dBm, and an audio signal of 400 Hz, with AM modulation of 30%.

Again, with the VCR in the Stop mode, connect the oscilloscope to pin 4 of PG751 and view the audio IF signal waveform. Apply +8.5 VDC to IC801 pin 12. Adjust L882 so the output is minimized.

**Video Output Level Adjustment**

With the VCR in the Stop mode, connect the color bar RF generator to the antenna input terminal of the VCR with an input for channel 13,  $-41 \pm 10$  dBm and a modulation degree of 87.5%.

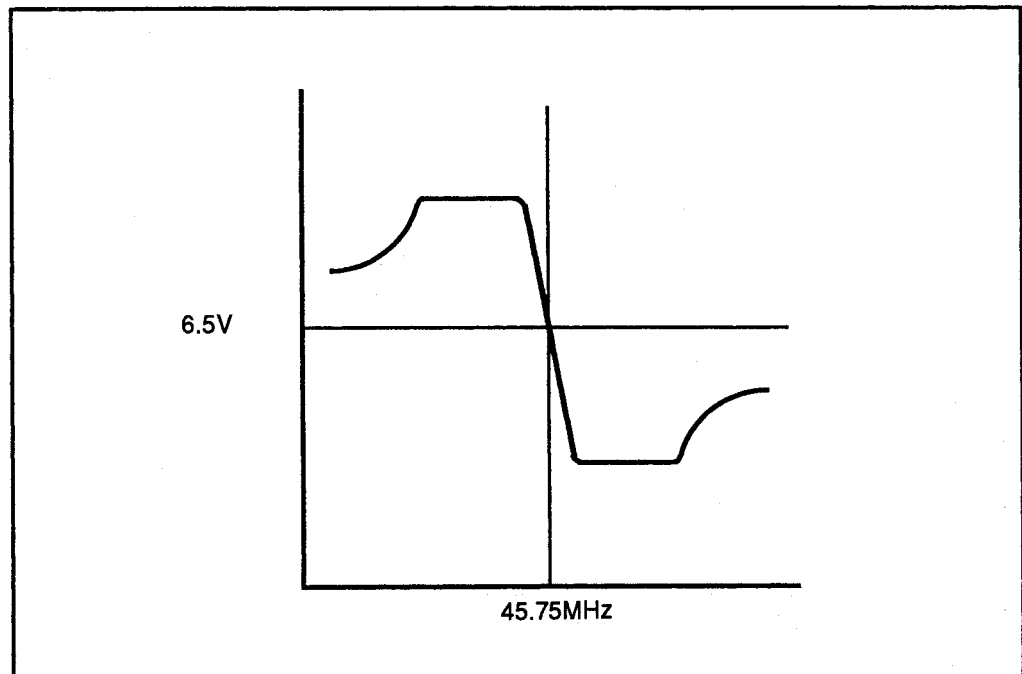


Figure 29: AFS waveform

Press the channel selector switch for the signal (channel 13) and tune for the best reception. Close the channel preset cover to activate the AFS circuit (AFS switch will be on). Connect the scope to pin 2 of PG751 and adjust R805 so the output level is 1 V P-P as shown in Figure 30.

**Audio Output Level Adjustment**

With the VCR in the Stop mode and the AFS switch on (and the channel preset cover closed), the TV signal generator should be connected to the antenna input

# 5/VCR

Video Recorder

5/VCR - VCS

Various Case Studies

5/VCR - VCS - HiVT34A

Hitachi VT-34A

of the VCR. The output of the generator should be for channel 13,  $-41 \pm 10$  dBm, at 30% modulation with a sine wave audio signal at 400 Hz).

Press the channel selector switch 13 and tune the best picture possible. Close the channel preset cover. Connect the oscilloscope to pin 4 of PG751. Adjust R890 so the output level is equal to  $-15 \pm 1.5$  dBm.

## RF AGC Adjustment

The color bar RF generator should be connected to the antenna input of the VCR. As before, tune channel 13 to the best picture possible. Close the preset cover.

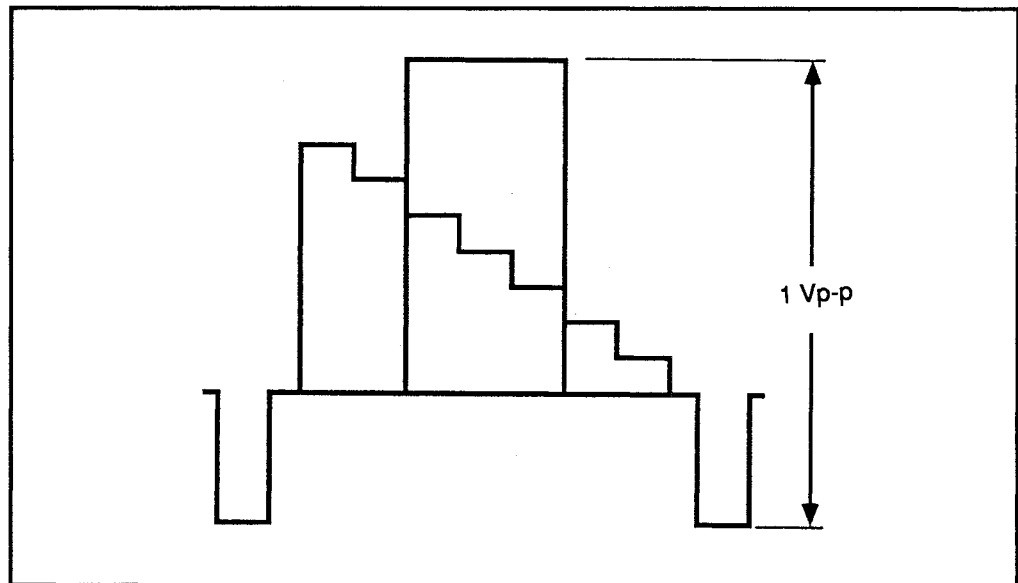


Figure 30: Video output level

## Main Chassis Part Removal

### Cassette Loading Mechanism

To remove the cassette loading mechanism, start by removing the top cover. This is done by removing the two screws at the top, back of the case. Lift the back of the case and remove the covers. Next, remove the front panel by removing the two screws at the top. Release the two stoppers to take out the shield cover. (This was shown in Figure 4.) Remove the reinforcement plate and disconnect the connector. Remove two screws on either side of the cassette loading mechanism assembly. Pull forward and lift the assembly out.

### Motor Block Assembly

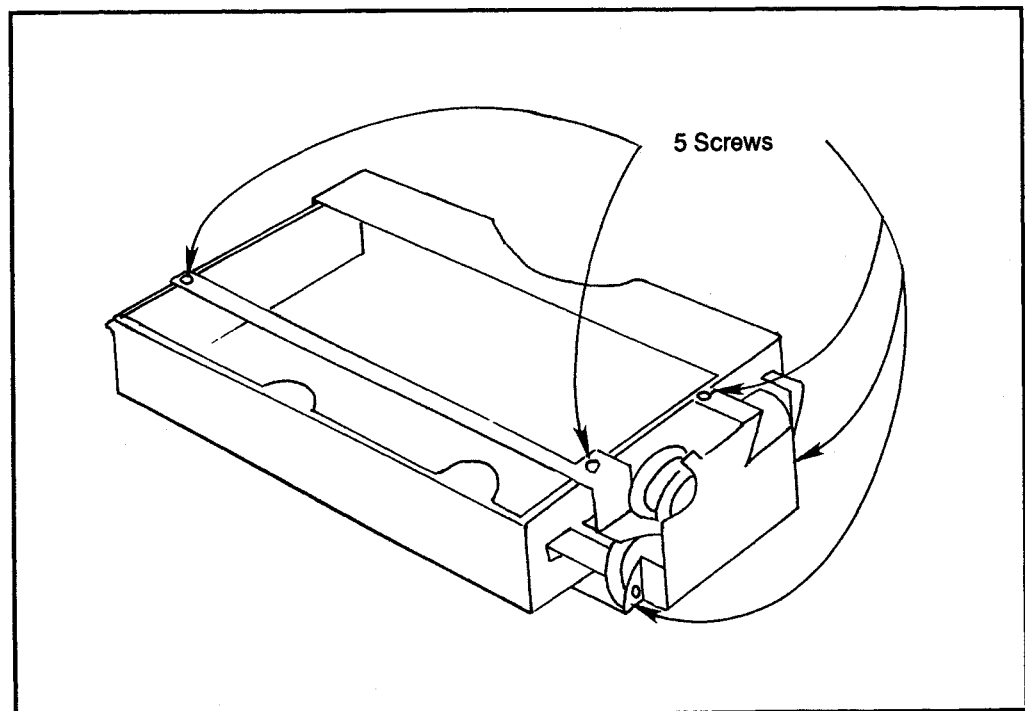
The cassette loading mechanism contains most everything needed to load the cassette into the VCR. The loading mechanism is shown in Figure 31. Located on the right side (as viewed from the front) can be found the motor block

assembly. This is the assembly that moves the cassette carriage in and down onto the cassette reels.

To remove the motor block assembly, start by removing the two screws that hold the reinforcing plate to the top front of the loading mechanism. Remove the three screws to remove the motor block assembly.

When replacing the motor assembly, check the following:

- Make sure that the markings found on the pinion gear and drive gear match. Figure 32 shows where this alignment takes place.
- Make sure that the markings on the motor block chassis and clutch gear match.
- The two pins of the switch lever should be inserted into the groove outside the drive gear. Figure 33 shows where this alignment takes place.
- The markings found on the motor assembly should be aligned in a horizontal line after having installed the motor block assembly. Figure 34 shows where this alignment takes place.



**Figure 31:** Loading mechanism assembly

### Cylinder Motor

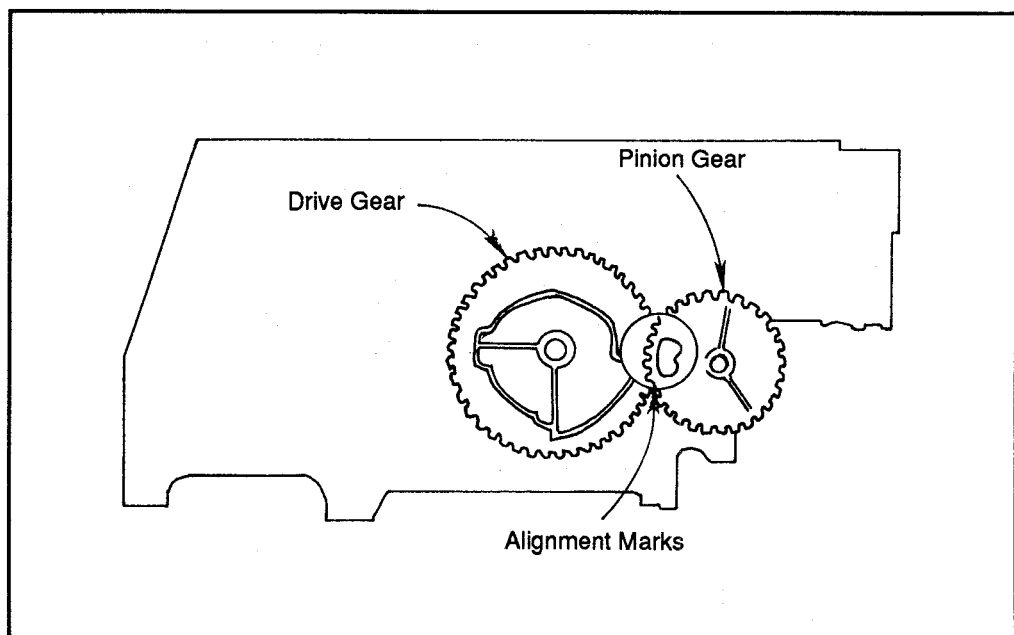
The cylinder motor contains the video head (upper cylinder), fixed lower cylinder, transformer terminals, FG circuit board, rotor magnet, and stator circuit board. The complete explosion of the parts is shown in Figure 35.

### Upper Cylinder

The video head (upper cylinder) can be accessed and removed or replaced. Remove the chassis cover then the shield cover over the cylinder. Next, remove the brush fixing screw.

Remove the 2 video head fixing screws to allow the removal of the video head. To replace the video head, do the reverse. After replacing a video head, check the following:

- The head fixing screws should be tightened. Do not touch the heads with a tool or finger, as this may damage them.
- Check that the leads of the rotary transformer (Figure 36) and the lead colors imprinted on the relay PC board are identical when soldering the leads after replacement.
- Clean the tape transport area (especially the installed cylinder). Perform a “transport system adjustment” as described in the alignment section.



**Figure 32:** Pinion gear and drive gear alignment



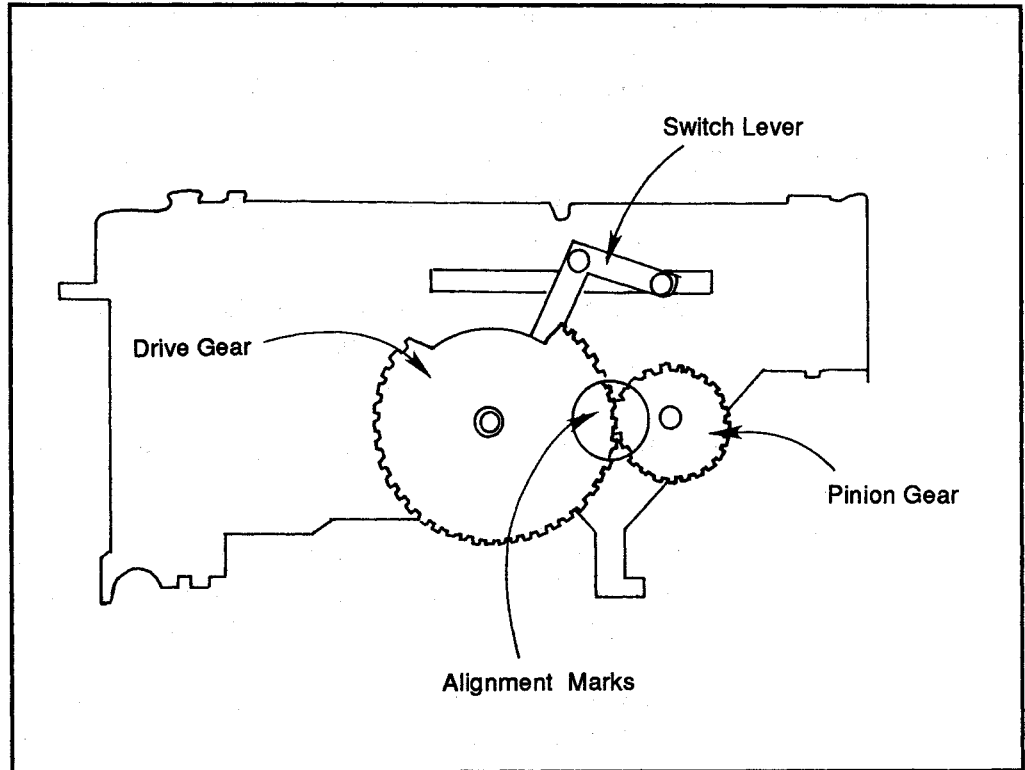


Figure 33: Switch lever pin alignment

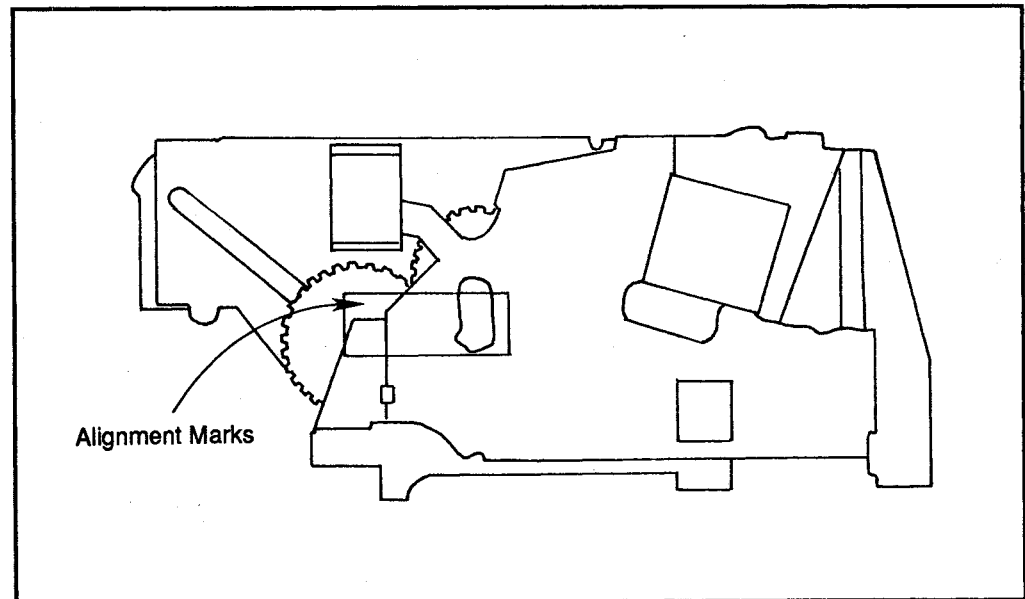
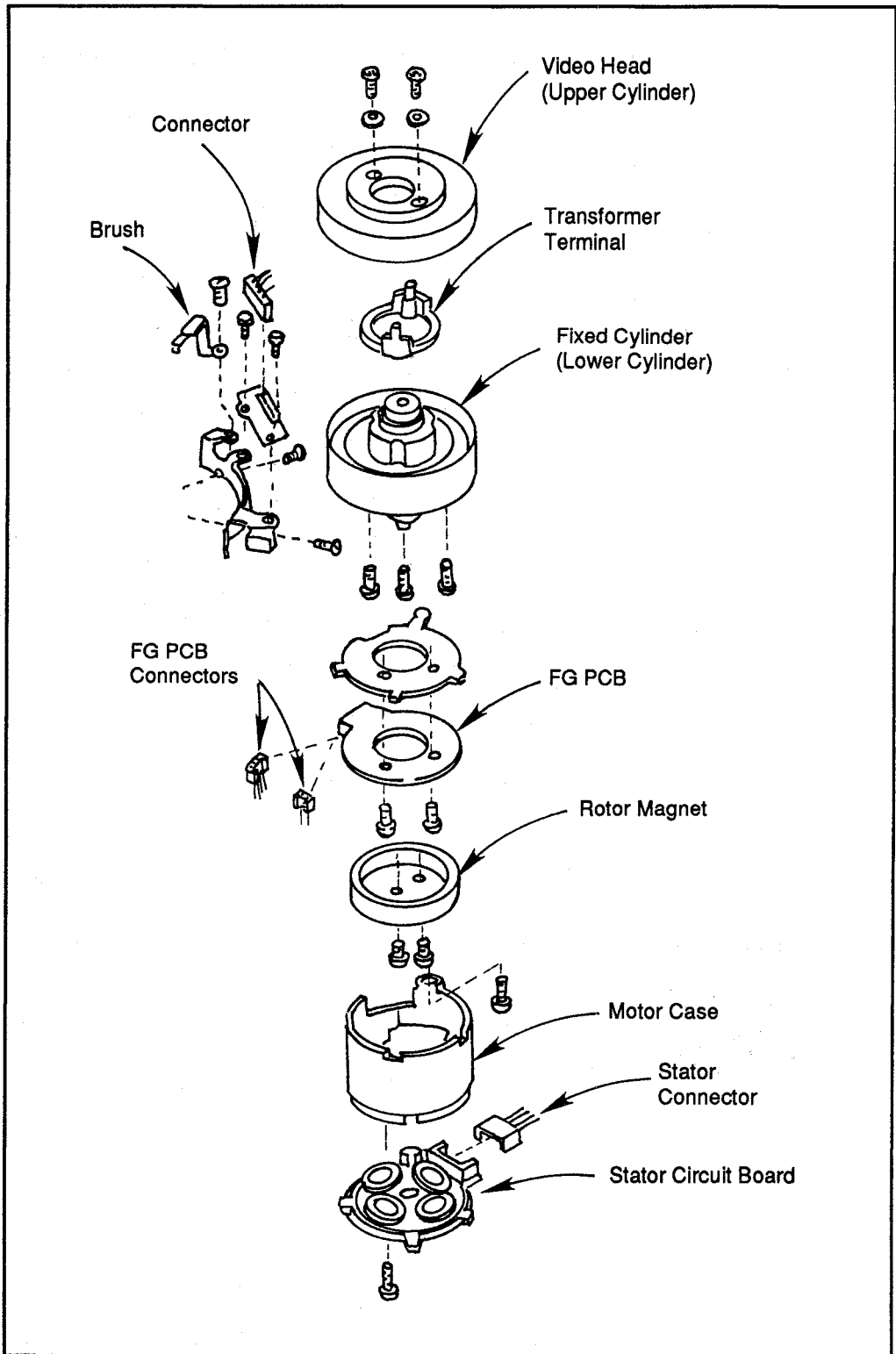


Figure 34: Motor marking alignments



**Figure 35:** Cylinder head parts explosion

This will allow the checking of the FM signal output.

- Perform a “record current adjustment” as described in the alignment section. This checks the level of the Y/C signals.
- Perform a “switching point” adjustment as described in the alignment section.
- The FM signal should be maximized with the tracking VR set to the center (click) position. Refer to the “tracking preset adjustment.”

### Lower Cylinder

To remove the lower cylinder, begin by removing the cylinder motor circuit board. Disconnect the 2 connectors from FG circuit board (FG PCB) as well as the connector to the stator circuit board.

Remove the three lower cylinder set screws and then remove the lower cylinder from the top of the chassis. Remove the upper cylinder from the lower cylinder. Replace, or reinstall the lower cylinder in the reverse order. Also, perform all the related testing as prescribed for the video head assembly.

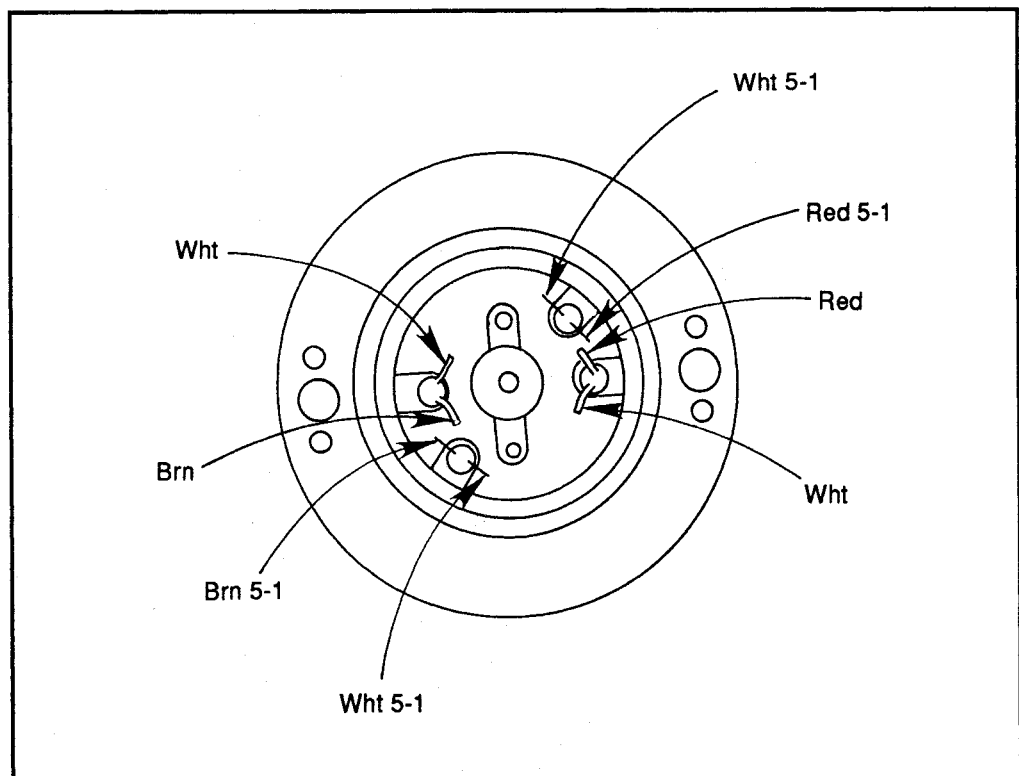


Figure 36: Video head assembly top view



5/VCR - VCS

Various Case Studies

5/VCR - VCS - HiVT34A

Hitachi VT-34A

### Transformer Terminals

The transformer terminals bridge the gap between the rotary transformers and the rotary circuits. If these leads become cut or shortened, they cannot be simply resoldered to the relay circuit board but must be replaced.

To remove/replace the transformer terminals, remove the video head as described above. Unsolder the leads beneath the transformer terminal and remove the terminal.

Install the new terminals in the reverse order. Make sure the lead colors and color names imprinted on the relay circuit board of the rotary transformer match.

### Rotary Magnet Assembly

The rotary magnets are high precision magnets and should not be attracted by other magnetic or iron materials. If so, the precise rotation of the motor will be changed making the unit unusable.

Also, the use of a "head demagnetizer" should only be used when the correct type of demagnetizer is available. DO NOT use an audio head demagnetizer as a video head demagnetizer, nor allow an audio head demagnetizer to come in close proximity to the rotory heads.

Handle the FG signal generating magnet installed to the back of the rotary magnets because the number of poles is set at 60 and the FG has a weak magnetizing force. This can be easily changed if a stronger magnetic field is present that is not the same as the FG.

To remove the rotary magnet assembly, begin by removing the motor case fixing screw. Turn the stator circuit board clockwise to remove the stator assembly.

Remove the two rotor magnet fixing screws then remove the rotor magnet. Be careful not to apply too much force to the cylinder shaft or it may become bent or damaged.

Reinstall in the reverse order. Check the following items after installation:

- There is a regulating convex section provided near the hole in the rotor magnet into which the shaft is inserted. This is there to allow the adjustment position during installation. Install the rotor magnet so this convex section enters the concave section provided in the shaft.
- Check the switching point of the video head after installing the rotor magnet.

# 5/VCR

Video Recorder

5/VCR - VCS

Various Case Studies

5/VCR - VCS - HiVT34A

Hitachi VT-34A

- Perform all video head related alignments and/or tests.

## FG PC Board Assembly

To remove the FG PC board, remove the stator PC board. Remove the rotor magnet as described before. Remove the motor case fixing screw. Turn the motor case clockwise and remove it. Remove the three FG PC board set screws.

Install the FG PC board in the reverse order. Follow the previous example to install the rotor magnet as well. Check all electrical adjustments and checks after installation as related to the cylinder head assembly.

## Loading Motor Assembly

Figure 37 shows the loading motor assembly. Removal of the motor is described here:

- Remove the loading belt
- Disconnect the connector as shown in Figure 37
- Remove the bracket fixing screw and remove the loading motor
- Install the loading motor in the reverse order
- Check the operation of the unit

## Flywheel

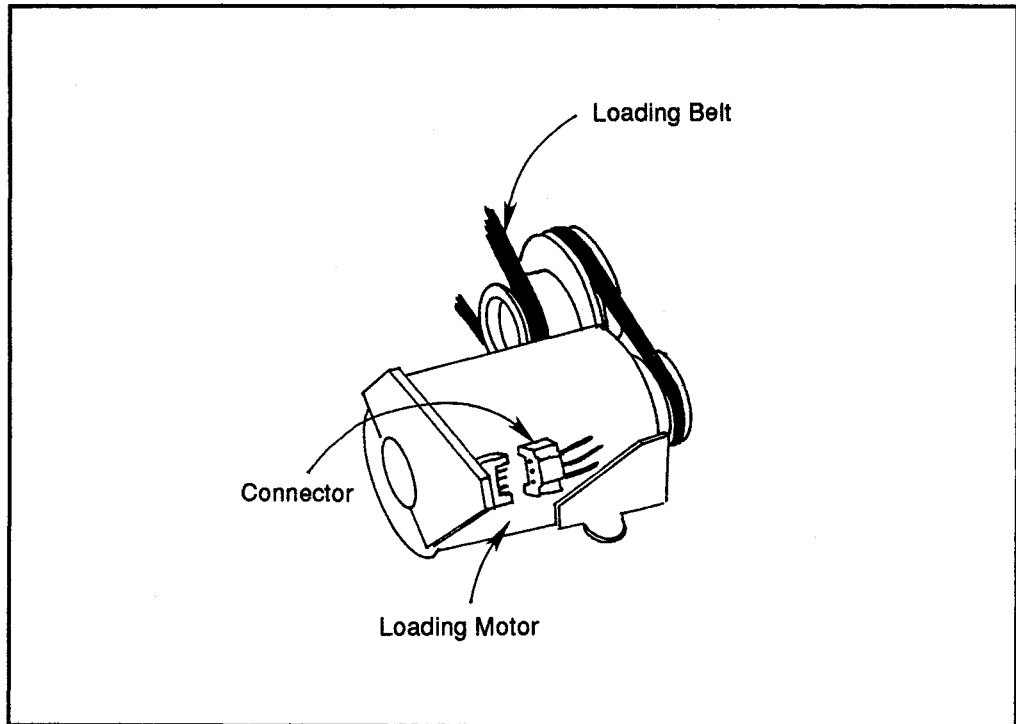
Figure 38 shows the flywheel assembly. The flywheel is found by working with the bottom of the VCR up. To replace, remove the two flywheel support plate fixing screws. Remove the flywheel.

Replace the flywheel in the reverse order. Insert the washer into the capstan shaft from the top of the chassis.

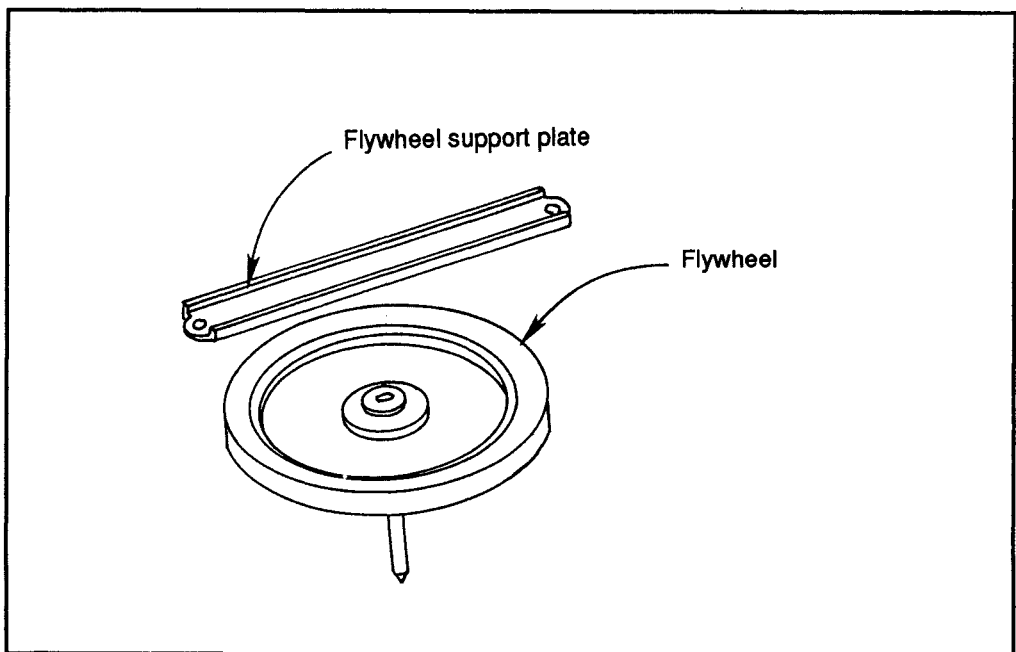
## Capstan Motor

The capstan motor drives the flywheel and the reel belt. If there is a problem with the capstan motor, the flywheel will not turn, the reel will not turn, and the tape will not be pulled through the VCR. Access the capstan motor from the bottom of the VCR. Figure 39 shows the capstan motor assembly. Remove the reel belt and the flywheel belt.

- Remove the two capstan motor fixing screws
- Remove the capstan motor assembly by lifting up. This includes the motor, holder, and circuit board
- Replace the capstan motor by the reverse of the described removal



**Figure 37:** Loading motor assembly



**Figure 38:** Flywheel assembly

- Check for any twisting, damage to belts, etc. after reinstalling.

**FF/REW Idler Arm Assembly**

A faulty idler arm assembly can cause problems such as tape mangling and erratic Fast Forward or Rewind. If installing a new tire doesn't cure the problem, replace the entire assembly. The FF/REW idler arm assembly is shown in Figure 40. The FF/REW idler arm is found between the supply and take-up reels.

To remove, move the spring holder in the direction of the arrow. Pull the FF/REW idler assembly up, and out of the machine. Replace in the reverse order.

**Clutch Plate Assembly**

Figure 41 shows the clutch plate assembly. Remove the FF/REW idler arm assembly as described before. Remove the two clutch plate fixing screws.

Press the main brake arms and the brake conversion arm in the direction of the arrow to release their engagement and lift the clutch plate assembly up and out of the VCR. Install the clutch plate assembly in the reverse order.

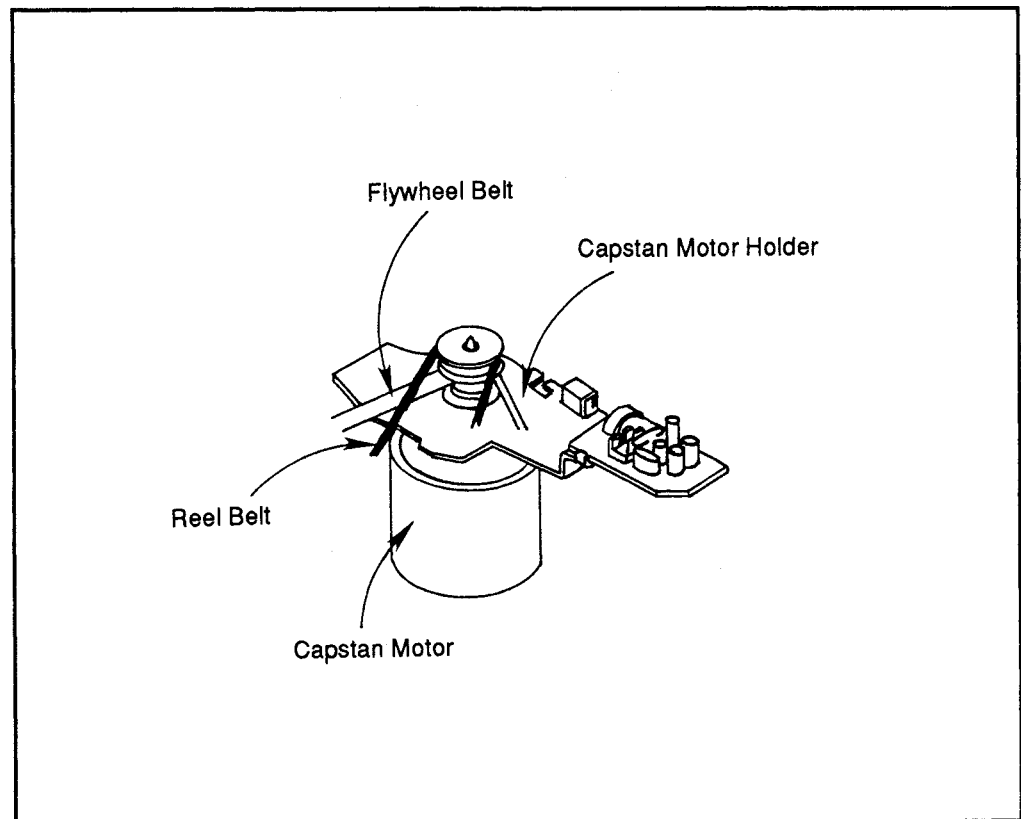


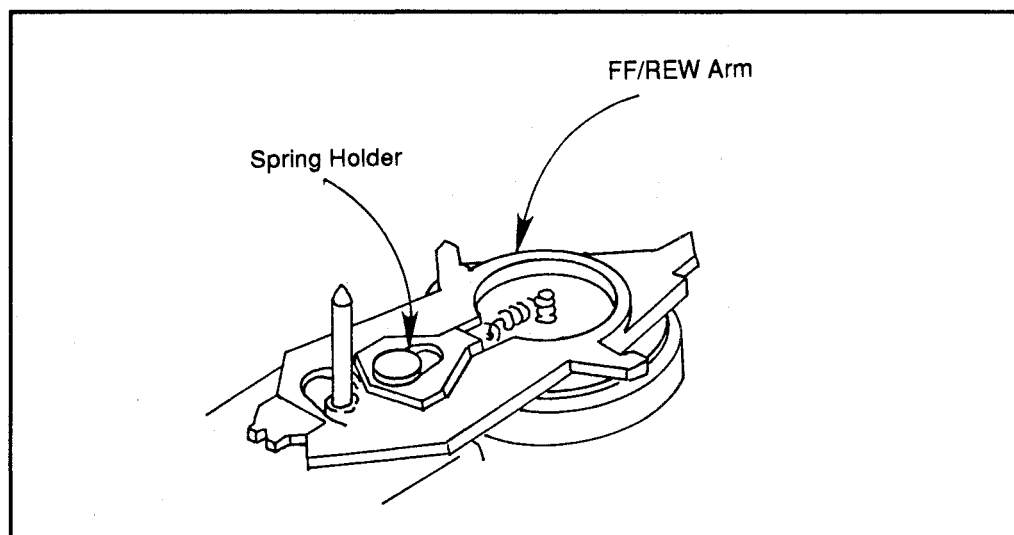
Figure 39: Capstan motor assembly

**Brake Slider  
 Assembly**

The brake slider assembly is also shown in Figure 41. Remove the FF/REW idler arm assembly as described before. Remove the clutch plate assembly. Remove the brake slider assembly fixing screw to remove the brake assembly. Install in the reverse order.

**Loading Gear  
 Assembly**

Figure 42 and Figure 43 show the loading gear assembly. Begin by turning the loading pulley until the unit is in the unloading mode, if it is not already. Remove



**Figure 40:** FF/REW idler arm assembly

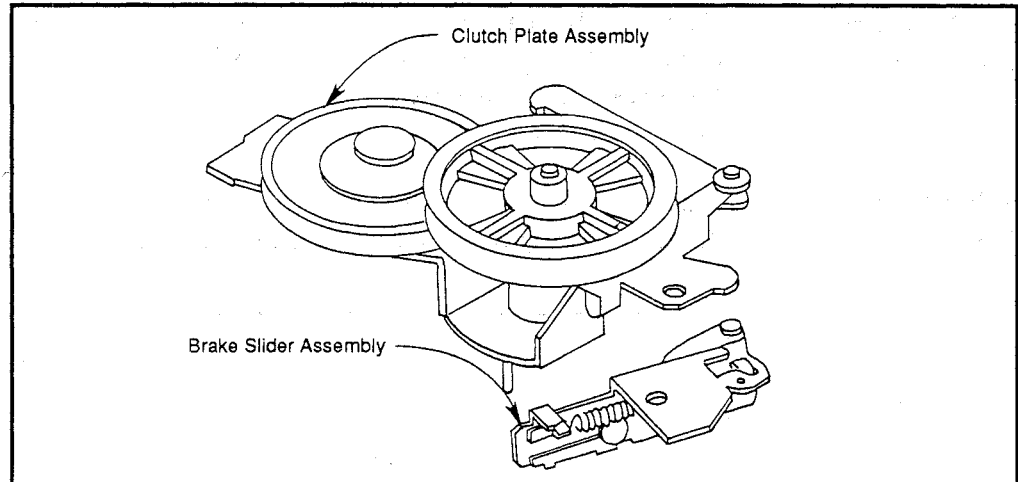
the mechanism state switch. Remove the clutch plate assembly and the brake slider assembly.

Remove the three loading gear assembly fixing screws of Figure 43. Remove the two guide base clamp plate fixing screws.

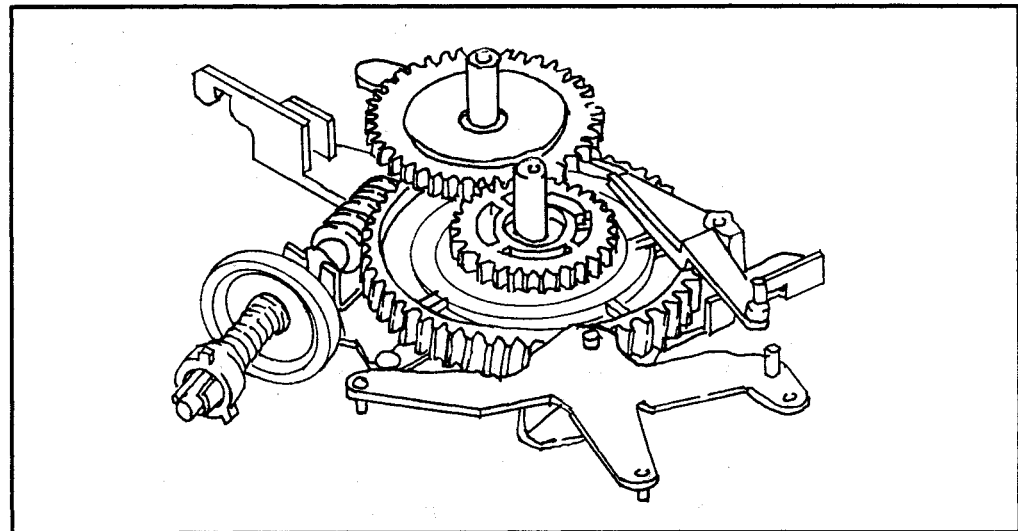
Remove the T release arm while pressing on the stopper shown in Figure 43 as shown by arrow B. Remove the loading gear assembly. Install in the reverse order, and check the following:

- The loading gear shaft should be inserted into the hole in the loading link.
- The operation arm shaft should be inserted into the hole in the T brake operation arm.
- The shaft of the T release arm 1 should be inserted into the hole in the T release arm 2.





**Figure 41:** Clutch plate assembly



**Figure 42:** Top view of the loading gear assembly

- The shaft of the drive arm should be inserted into the hole found in the coupling piece.
- Check and align the position of the mechanism state switch after installation.

### Tension Band and Tension Arm Assembly

Figure 44 shows the tension band and tension arm assembly. Remove the cassette loading mechanism. Remove the tension band fixing screw. Press stopper A of the tension band felt so the tension band and tension felt are disengaged and then remove the tension band.

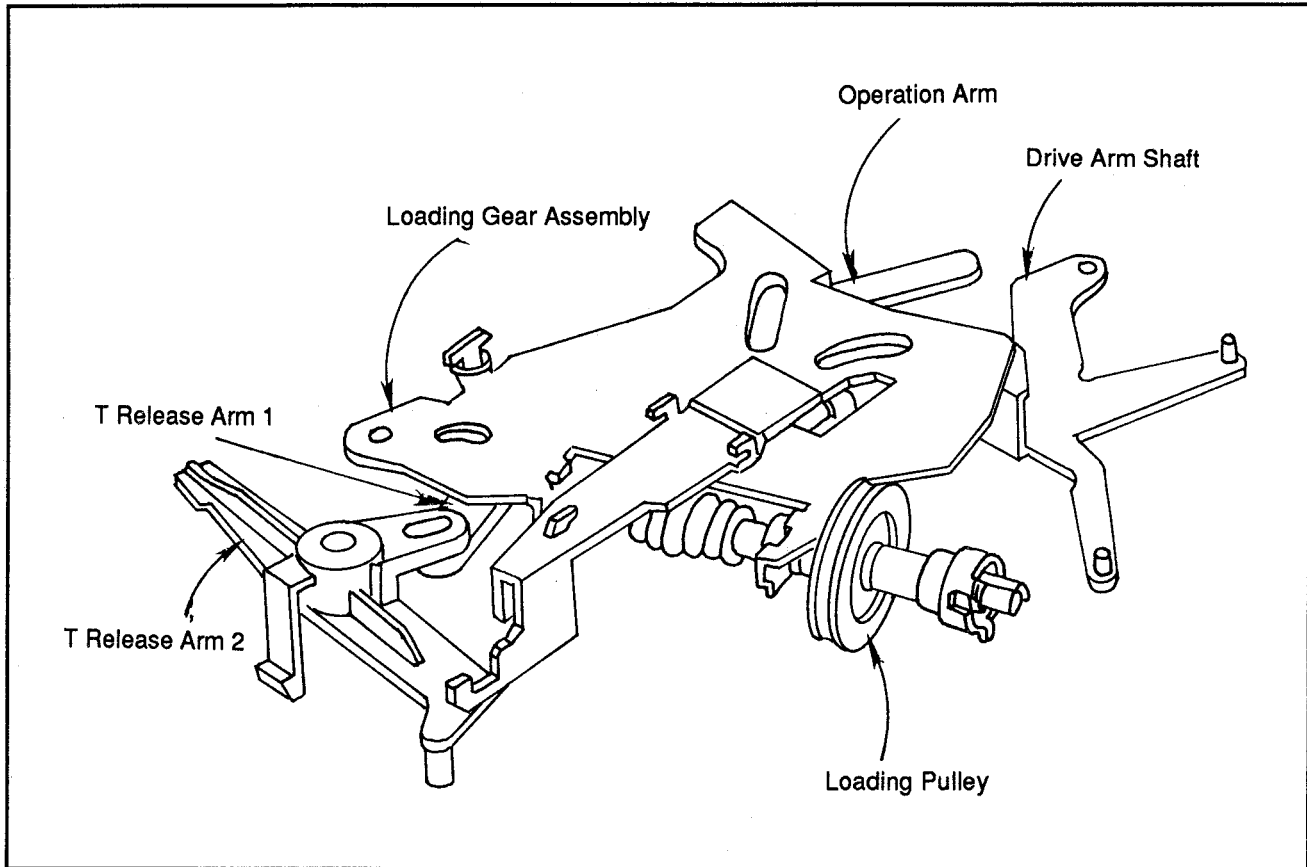


Figure 43: Bottom view of the loading gear assembly

Remove the tension band. Remove the spring. Remove the tension arm by pulling up and out while depressing the stopper, B. Install in the reverse order. Adjust the position of the pole and tension.

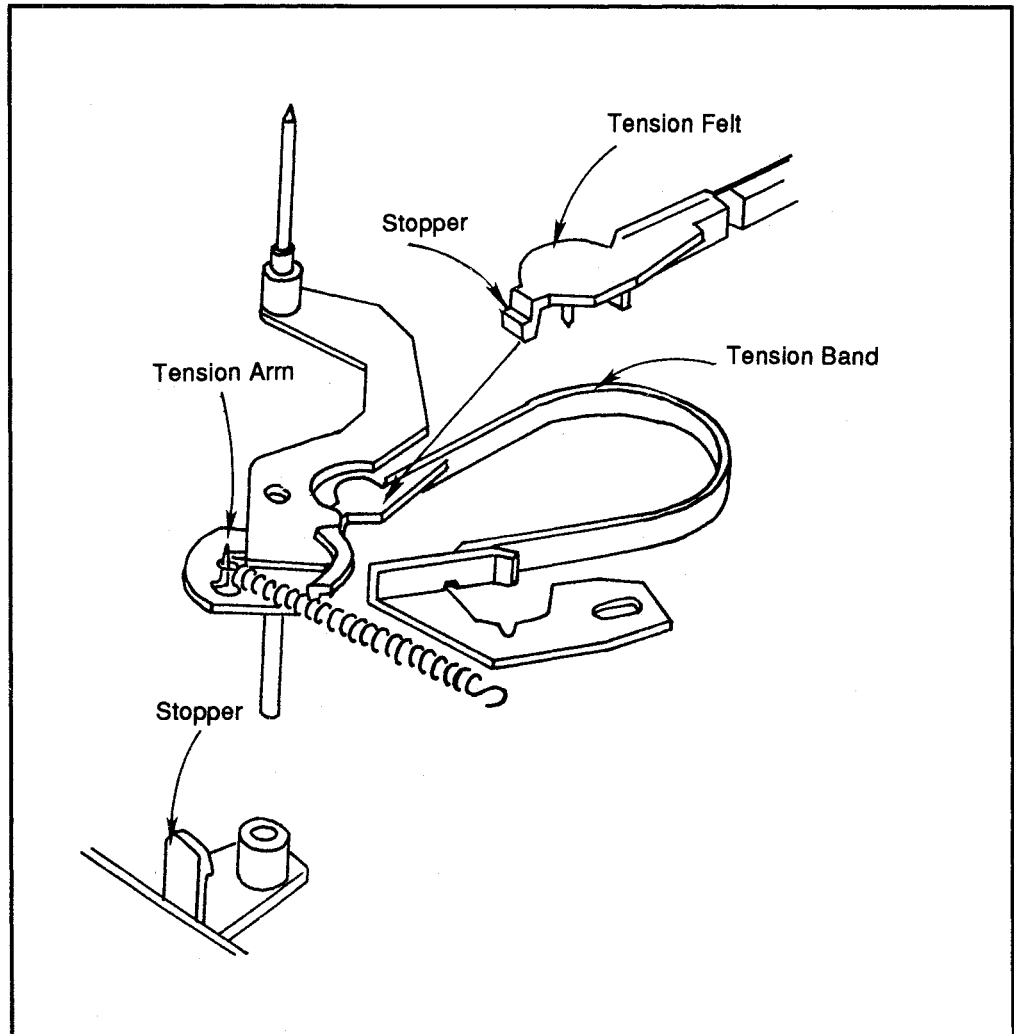
### Take-up and Supply Reels

Figure 45 shows the take-up and supply reel assembly area. Begin by removing the cassette loading mechanism described earlier in this section. Remove the washer from either/both of the take-up and supply reels and remove either/both.

Remove the pressure roller fixing screw. Remove the pressure roller. Remove the pressure roller fixing washer. Remove the pressure roller fixing arm.

The arm bracket assembly can be removed by removing the take-up reel disk, and the pressure roller arm. Remove the two arm bracket fixing screws.

Reinstall type items in the reverse order.



**Figure 44:** Tension band and tension arm assembly

### Guide Pole and Full Erase Head

The guide pole and full erase (FE) head are located on the same assembly and shown in Figure 46. To remove the guide pole, remove the guide pole nut. Adjust the height of the guide pole after installing the guide pole as described in the guide pole alignment section.

To remove the FE head, remove the guide pole. Remove the spring. Remove the spring from the impedance roller. Remove the impedance roller assembly. Remove the FE head fixing screw. Install the parts in the reverse order. Make the adjustments required for the area as described in the alignment section.

# 5/VCR

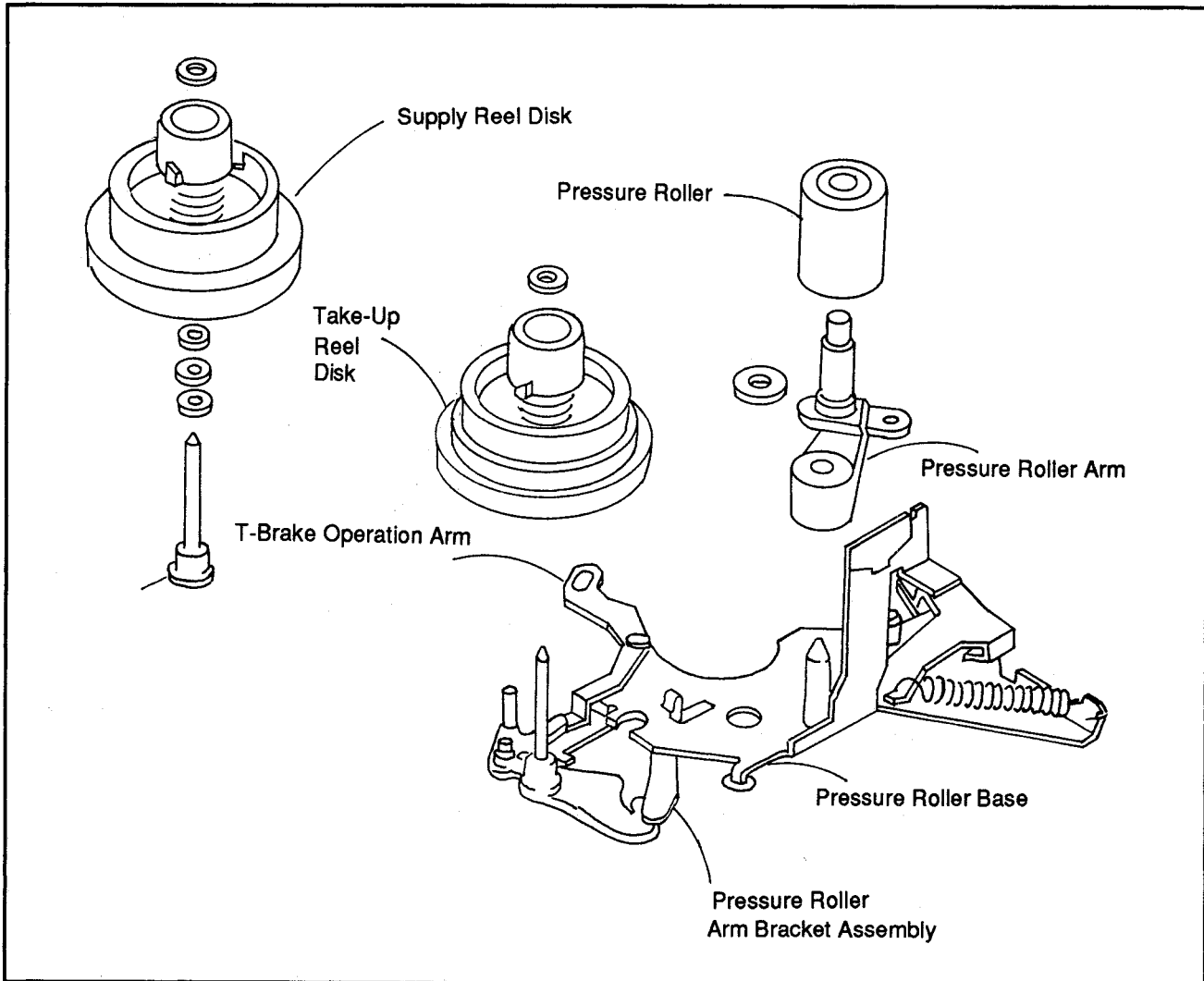
Video Recorder

5/VCR - VCS

Various Case Studies

5/VCR - VCS - HiVT34A

Hitachi VT-34A



**Figure 45:** Take-up and supply reel assembly area

## Audio/Control Head

The Audio/Control (AC) head assembly is shown in Figure 47. Begin by removing the wiring guide. Remove the head base fixing nut and washer. Remove the AC head assembly.

Tighten head fixing screw to the extent that it comes out approximately 1 mm above the top of the AC head base after replace the unit. Tighten the fixing screws until the head base and the AC head base are set parallel as dependent to the height of the convex section of the head base. Insert the spring between the AC head assembly and the chassis to install the AC head to the chassis. Do all the related adjustments for the AC head system.

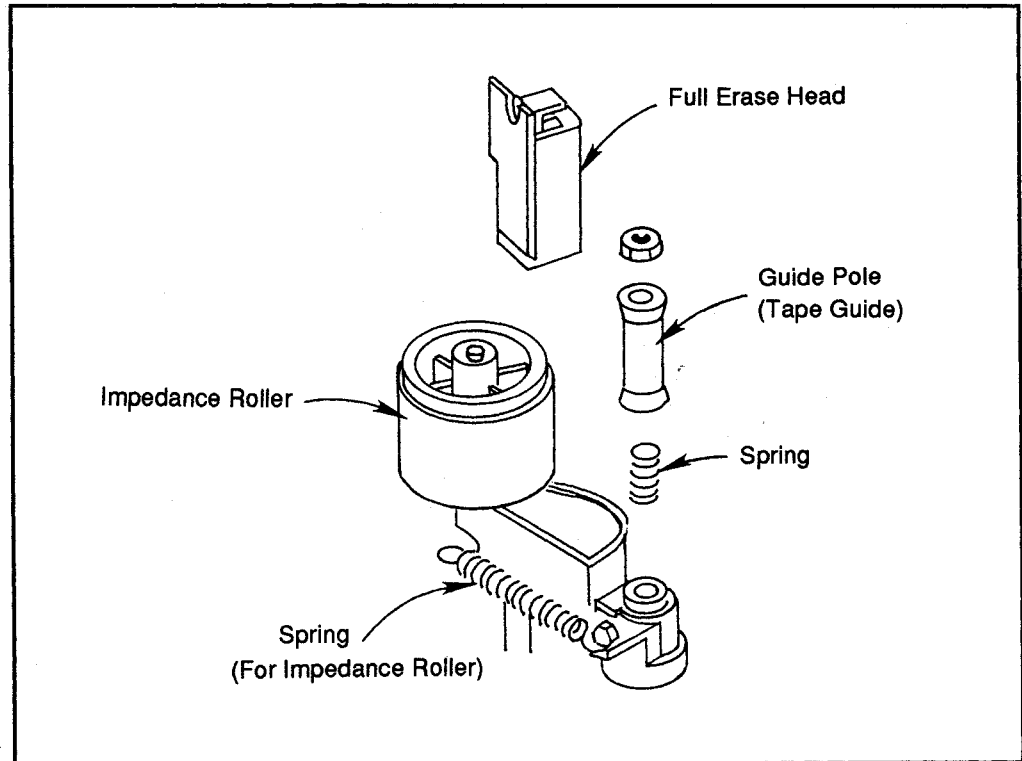


Figure 46: Guide pole and full erase head

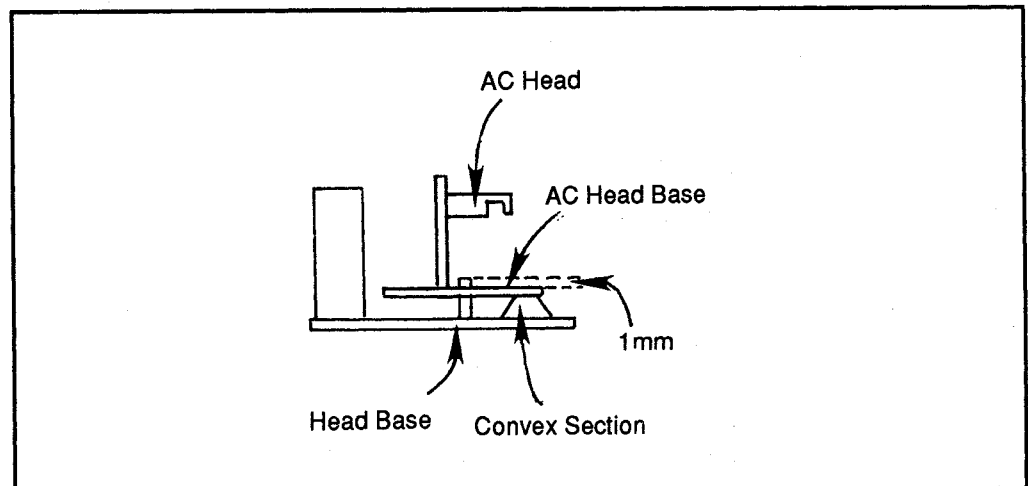


Figure 47: Audio/Control head



---

5/VCR - VCS

Various Case Studies

---

5/VCR - VCS - HiVT34A

Hitachi VT-34A

---

# Section 6 Television

---

## Table of Contents

<b>6/TTV</b>	<i>Tube Television</i>
<b>6/TTV - A</b>	<i>An Introduction</i>
<b>6/TTV - TE</b>	<i>Test Equipment</i>
<b>6/TTV - TE - TV/V</b>	<i>Specialized TV &amp; Video Servicing Equipment</i>
<b>6/TTV - TR</b>	<i>Troubleshooting and Repair</i>
<b>6/TTV - TR - A</b>	<i>An Introduction</i>
<b>6/TTV - TR - AS</b>	<i>Audio Section</i>
<b>6/TTV - TR - BA</b>	<i>Bandwidth Amplifier</i>
<b>6/TTV - TR - CPT</b>	<i>Color Picture Tube</i>
<b>6/TTV - TR - DC</b>	<i>Deflection Circuit</i>
<b>6/TTV - TR - FPC</b>	<i>Frequency and Phase Control (Automatic)</i>
<b>6/TTV - TR - IFA</b>	<i>IF Amplifier</i>
<b>6/TTV - TR - PS</b>	<i>Power Supplies</i>
<b>6/TTV - TR - T</b>	<i>Tuner</i>
<b>6/TTV - TR - VS</b>	<i>Video Signals</i>
<b>6/TTV - VCS</b>	<i>Various Case Studies</i>
<b>6/TTV - VCS - MagT985/T986</b>	<i>Magnavox Chassis T985-05/-06/-07/-08, T986-06</i>

Table of  
Contents

---

---

---

---



**6/TTV**  
**Tube TV**

---

**6/TTV - A**  
**An Introduction**

---

For a color television to function properly, several qualities must be included. These are contrast, brightness, gamma, color saturation, color hue and detail.

**Contrast**

Contrast refers to the difference between adjacent shades of black and white, or the steps of gray. Having only black and white would have a contrast level of 2. A light gray against a white would be low in contrast, as would a soft green against a light blue.

Lighting conditions in the viewing room often affect the perception of contrast. A user adjustment is found on televisions to help. A room with a high degree of light requires more contrast than a room with less available light. The contrast level controller adjusts the amplitude of the video signal applied to the picture-tube control grid.

**Brightness**

The brightness of a picture refers to the overall intensity of the image on the screen. As with contrast levels, the brightness depends upon the room in which the receiver is being viewed, as well as personal preference.

The brightness control varies the amount of negative bias on the picture tube control grid. The higher the negative bias voltage, the less bright the picture. In some television sets there is an automatic brightness optical sensor which varies the negative bias voltage depending on ambient light.

**Gamma**

The gamma measurement indicates the relative contrast between an original scene and a reproduced television image of that scene. If the original image and the reproduced image are equal, then the gamma equals 1. A washed-out signal suggests a gamma of less than 1. A gamma greater than 1 produces a picture with excessive contrast.

**Color Saturation**

Color saturation is the level of color in an image. In other words, it is the amount of a particular color that is used to produce that color. Too little color saturation will produce a black-and-white signal. At the other end, a picture with too much

color saturation will produce a signal with too intense or unnatural colors.

Color saturation is dependent on the adjustment of the 3.58 MHz color signal. Increasing the adjustment will increase the amplitude of color saturation and decreasing the adjustment will decrease the amount of color saturation.

**Hue**

The tint, or hue, refers to the actual colors, like red, green, blue, etc. Color information is transmitted as phase differences between portions of the color burst, or color signal. By changing the phase difference in the signal, you can create different colors. Many TVs of today use automatic color control (ACC) and automatic tint control (ATC) circuits to adjust the color to a proper level. This is controlled by the portion of a video color signal referred to as the vertical interval reference (VIR).

**Detail**

Detail is the sharpness of a picture. Detail is also referred to as resolution and definition. The number of elements, or pixels in a picture describe the resolution of the image and are directly related to the detail. A broadcast signal has 483 lines of picture information with each line containing 540 pixels. This remains constant for every size and shape of receiver, so having a bigger screen doesn't make for a better picture. Larger sets have larger images, but also have larger pixels. This is why projection screen televisions appear less detailed than smaller tube sets.

# 6/TTV

Tube TV

6/TTV - TE

Test Equipment

6/TTV - TE - TV/V

Specialized TV &amp; Video Servicing Equipment

## 6/TTV - TE

### Test Equipment

## 6/TTV - TE - TV/V

### Specialized TV & Video Servicing Equipment

All of the test equipment discussed in Section "4 Tools and Test Equipment" will be used when repairing video equipment like television receivers, video cameras, camcorders, VCRs and video disc systems. However, there are a few additional, specialized pieces of equipment required to perform proper repairs and adjustments.

#### Waveform Monitors

A type of special equipment used when checking video signals in television and video equipment is the waveform monitor. A waveform monitor is a specially calibrated instrument designed to process a video signal and display it on a screen

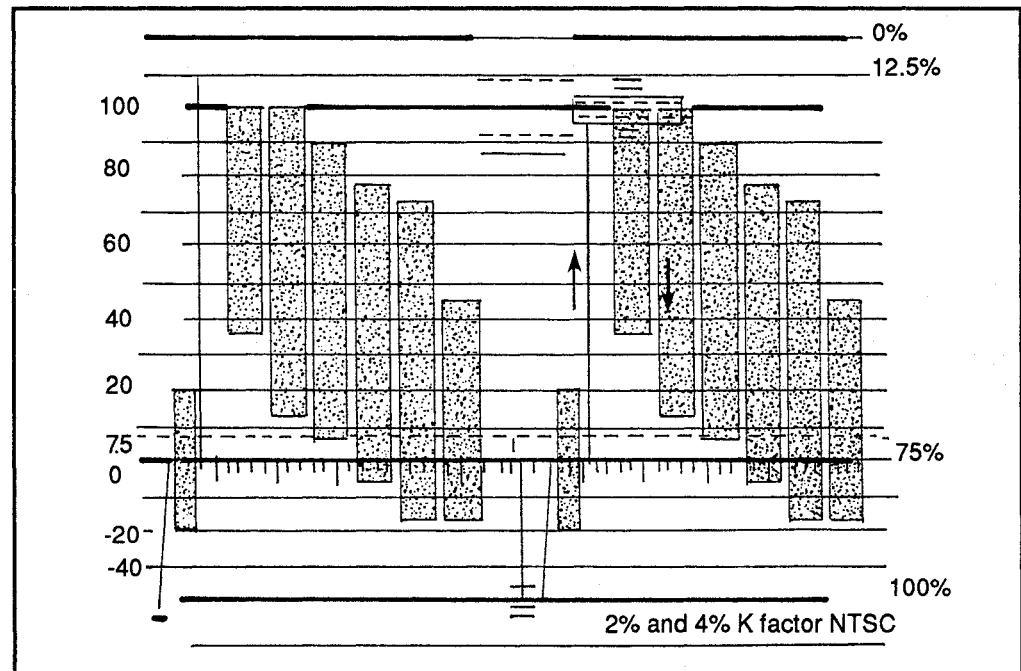


Figure 1: Waveform showing 1 V peak-to-peak

(while adhering to the NTSC video standard). Actually, a waveform monitor deals with the luminance, or the black-and-white portion of a video signal. Video signals are specified as 1 V peak-to-peak which is measured from the lowest tip of sync to the brightest peak white. This is shown in Figure 1.

Normally a video signal is measured in the 2-line sweep mode, or the 2H position when viewing a waveform of a video signal. The bottom of the sync is set so it is on the -40 IRE line and the top bar should not exceed the 100 IRE marking.

IRE stands for Institute of Radio Engineers, who were the original broadcast engineering group. This group established many of the television standards used today.

A video signal of 1 V relates to 140 IRE which is why the signal starts at -40 and peaks at 100. This way of measuring a video sync level of 40 IRE is easier than saying 3/10 V.

Sync is the synchronizing pulse in the vertical and horizontal retrace interval of a video signal. These pulses keep video signals matched, or in sync. Without a sync signal, it would be impossible to record a video signal or display a video signal on a television.

The picture or video area occupies the 7.5 IRE to 100 IRE. Any level above 100 IRE is considered bad and could cause problems in the final output, usually as a buzzing sound in the audio playback. If the video level does not approach the 100 IRE level, the video picture will appear dark. If the black level drops below the standard 7.5 IRE, low-level video is crushed. Video level is not considered bad if these levels are not met while viewing live video. There may not be blacks or whites that approach these limits, but if there are and they do not exceed these limits, the video signal can be assumed to be properly adjusted. Television studio equipment can handle levels up to 120 IRE and most will clip levels at a preset 105 IRE to prevent problems. Home equipment will have a degraded picture from video signals that are too high. (This is especially true if the signal was recorded and played back on a VCR.)

White is set at 100 IRE. You might think that black should then, logically, be at 0 IRE. This is not the case. Official TV black level happens at 7.5 IRE and is often referred to as the setup, or pedestal level. If the luminance portion drops below the 0 IRE level, it will interfere with video processing circuits. This level provides a safety margin of 7.5 IRE, then, to protect such circuits. There is what is known as "super-black" at a level of 3.5 IRE, which is used for key source

# 6/TTV

Tube TV

6/TTV - TE

Test Equipment

6/TTV - TE - TV/V

Specialized TV &amp; Video Servicing Equipment

information. For your purposes of video repair in NTSC video, however, you should always stay close to the 7.5 IRE level. Otherwise, details in darker areas will be lost.

Looking at the waveform display in Figure 1, we see a flat bar and six colored bars modulated with a subcarrier frequency from a color bar generator. The first step (a flat step at 100 IRE or 77 IRE, depending on the generator) is the white bar. The next six are the actual color bars. They are yellow, cyan, green, magenta, red and blue. There is also a bar at 7.5 IRE that is unmodulated. You will remember from above that this is the black bar in the pattern. The greater each color's bulk, the greater its modulation is displayed on the waveform monitor screen.

Flipping a switch on the front panel to the flat position will remove the color burst and chrominance from the waveform, leaving the luminance signal. This is the normal selection for adjusting video levels.

## Vectorscopes

Another type of special video test equipment available is the vectorscope. The vectorscope measures the chroma, or color, levels and can measure system timing, SC/H (subcarrier/horizontal) phase and non-linear distortions. Figure 2 shows a vectorscope display with properly set-up chroma levels.

A vectorscope is normally used to check the proper set-up of a video signal that is recorded or sent out over the air. Therefore, a vectorscope can be very useful in checking the proper playback of VCR, the output of a camera, or a monitor/

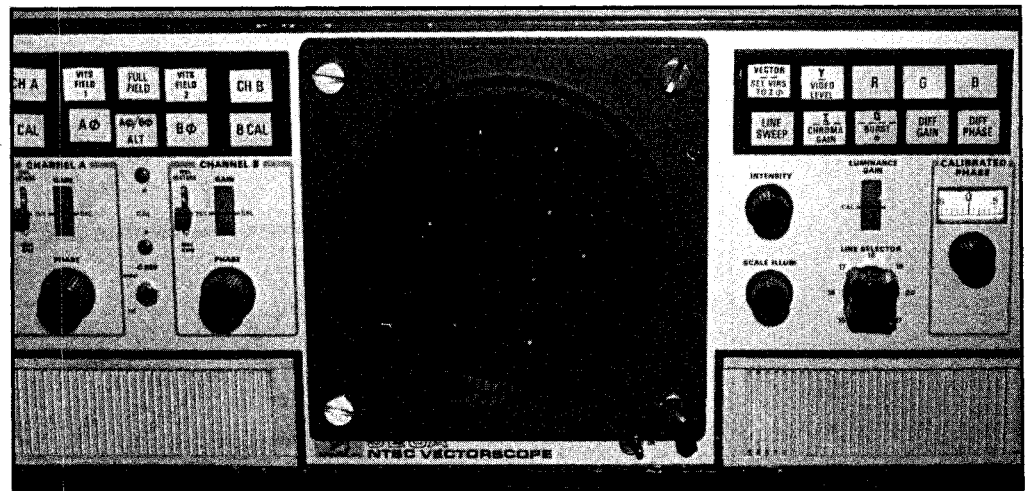
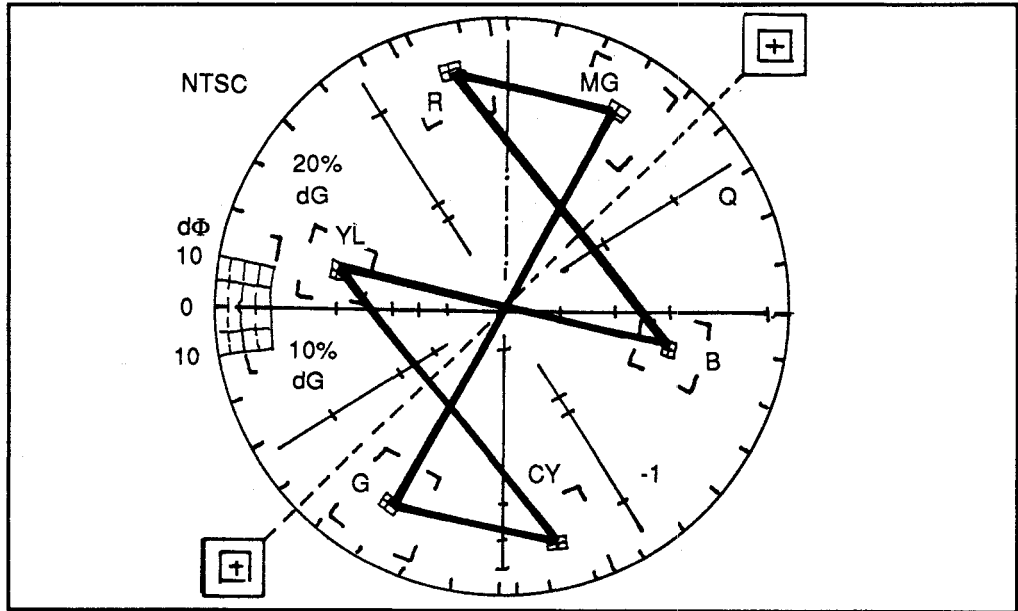
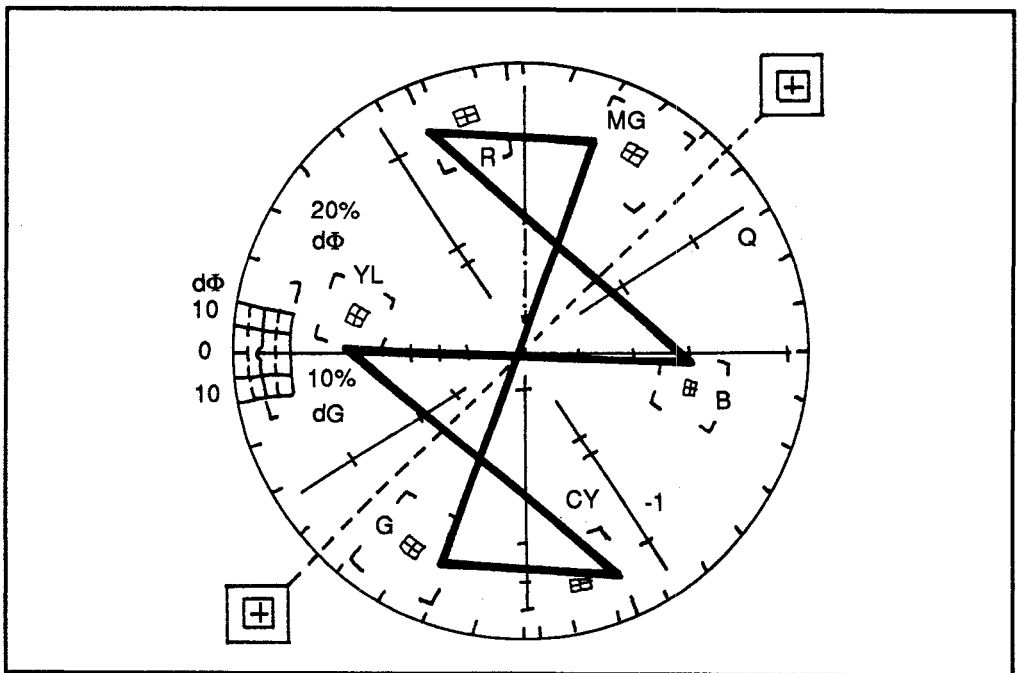


Figure 2: Vectorscope



**Figure 3:** Vectorscope display showing correct chroma levels

television with video out. The test signal to be input to these devices for testing would be a color bar display. By sending the color bar output of a device we can view the waveforms on a vectorscope and determine if there is a problem in the



**Figure 4:** Improperly adjusted hue

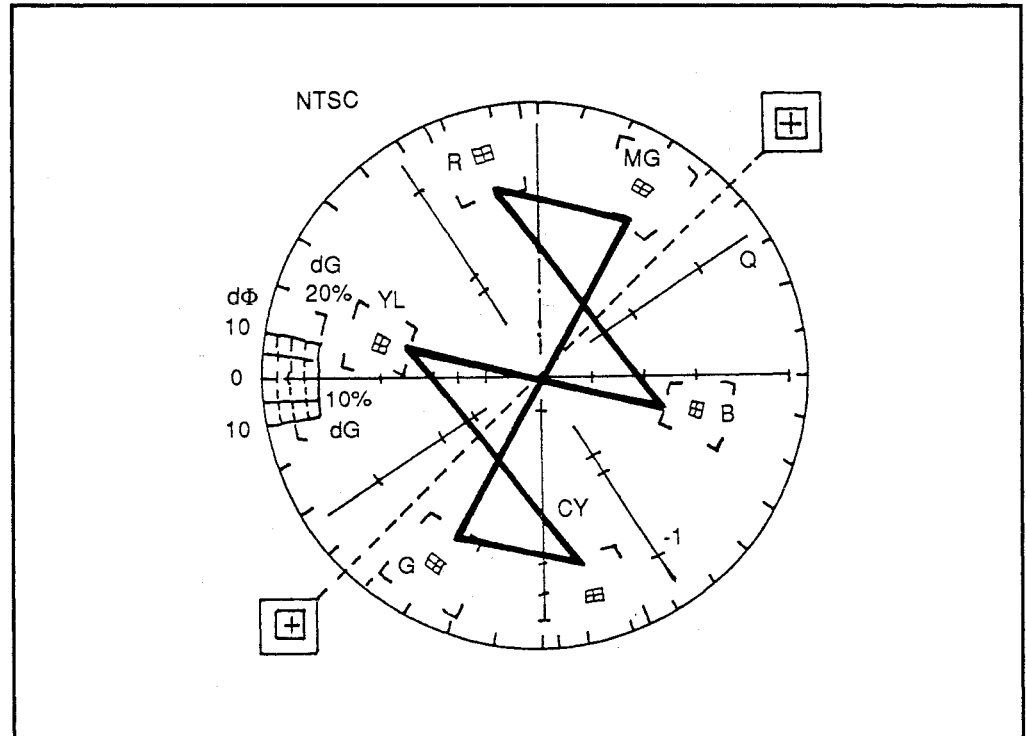


Figure 5: Low chroma level

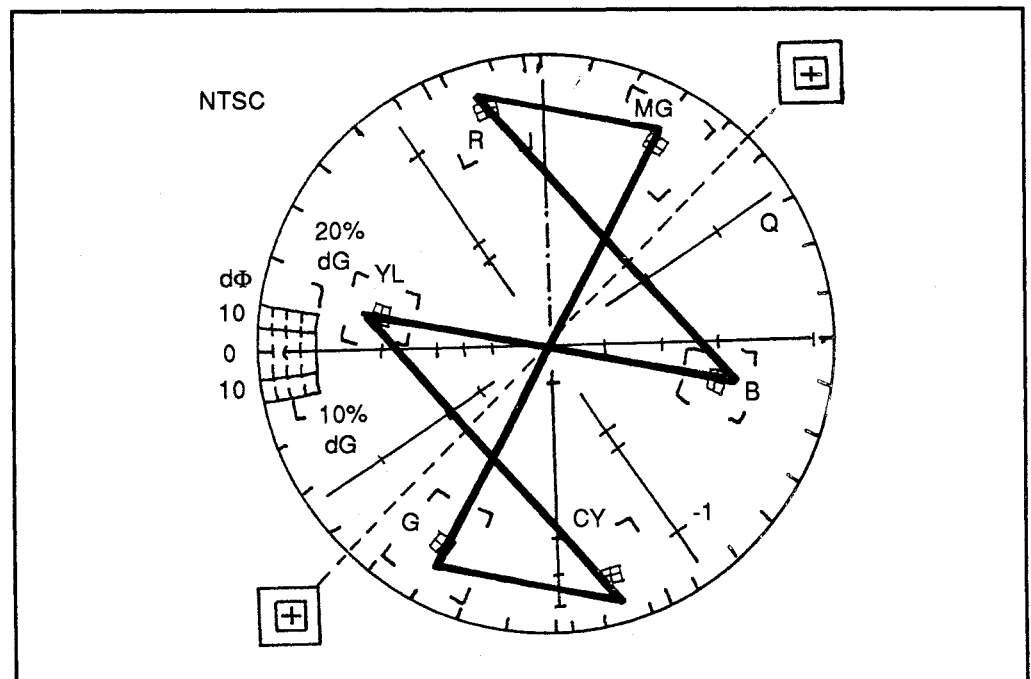


Figure 6: High chroma level

device. The phase control of the scope should be set at the 9 o'clock position. When a proper color-bar signal is sent to the vectorscope, the color-bar dots will center on the cross hairs inside the small boxes. Minor shifts from the cross hairs are within acceptable limits and normal. The box represents a 2 % error margin, and the larger box represents a 20 % error margin.

If the whole array of dots seems to be rotated to the right or the left of the boxes, you have a hue or chroma level problem. Figure 4 shows this. Adjusting the hue control should correct this problem.

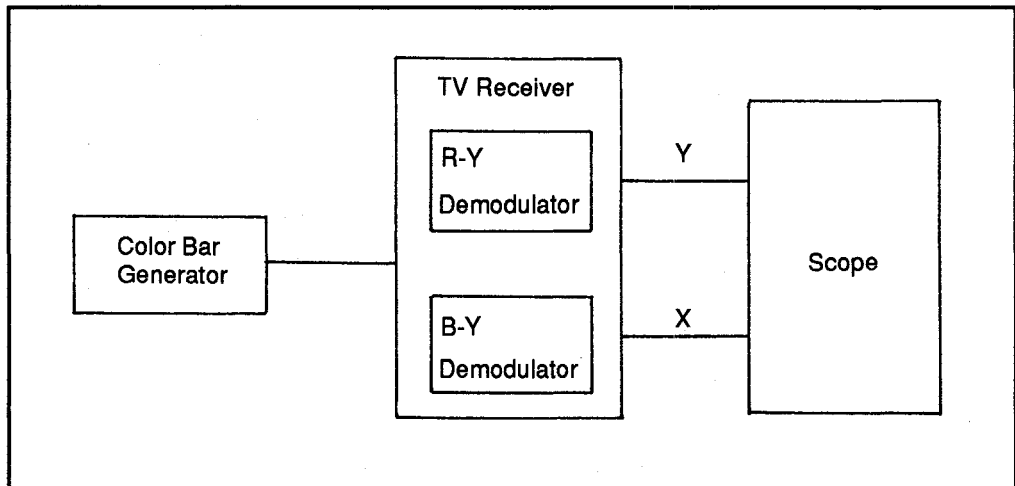


Figure 7: Connecting an oscilloscope to view vectorgrams

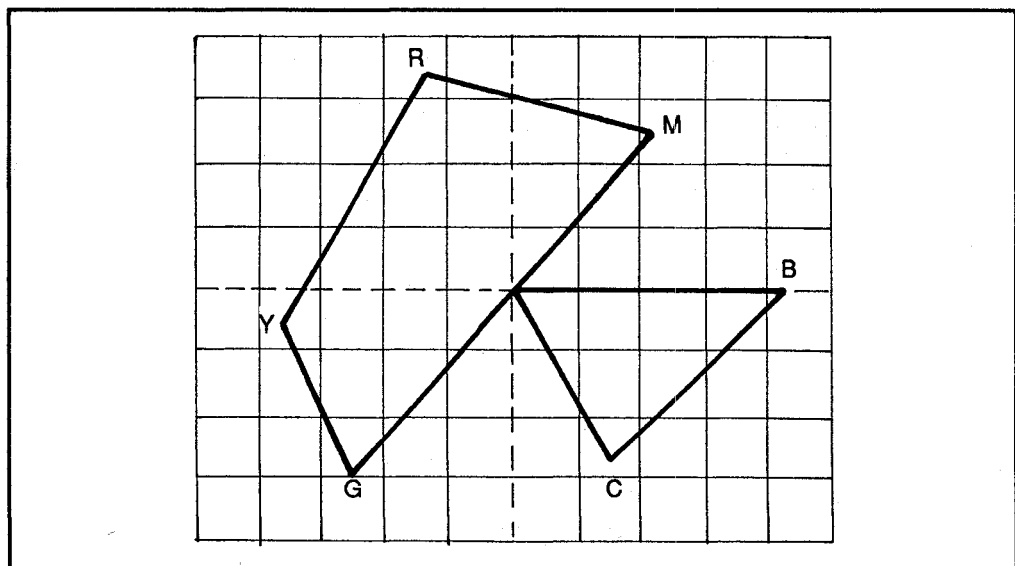
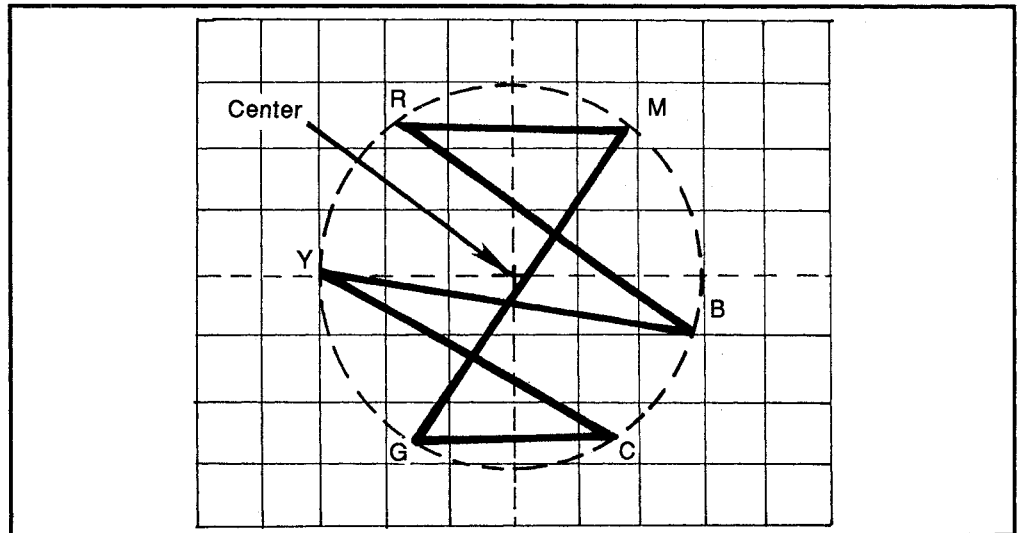


Figure 8: Typical vectorgram display



If the dots do not reach the boxes at all as in Figure 5 then the chroma level is too low. If the opposite happens, as in Figure 6, then the chroma level is too high. In either case, the chroma level output needs to be increased or decreased to correct this problem.



**Figure 9:** Baseline curvature

A vectorscope is basically an oscilloscope that is capable of displaying Lissajous patterns of chroma waveforms. These types of Lissajous patterns are called vectorgrams. Most vectorgrams are created by a color-bar generator.

Viewing vectorgrams can be done by connecting an oscilloscope to the outputs of the R-Y and B-Y demodulators as shown in Figure 7. The resulting pattern is shown in Figure 8. The vectorgrams will not be as pretty as the examples. Actual vectorgrams tend to be rounded with no two petals of the wave exactly alike. This happens from the residual phase errors indicated by the lack of angular uniformity.

If the R-Y and B-Y signal channels have subnormal bandwidth, there will be a distortion of the waveforms, which may cause curvature in the wave. Figure 9 shows an example of baseline curvature. The spokes of the pattern do not reach the center point in the vectorgram. This space has a circular boundary when the R-Y and B-Y waveforms have equal baseline curvatures.

When viewing pictures on television screens, always remember that a television is a very forgiving piece of equipment. By adjusting hue, color, brightness and

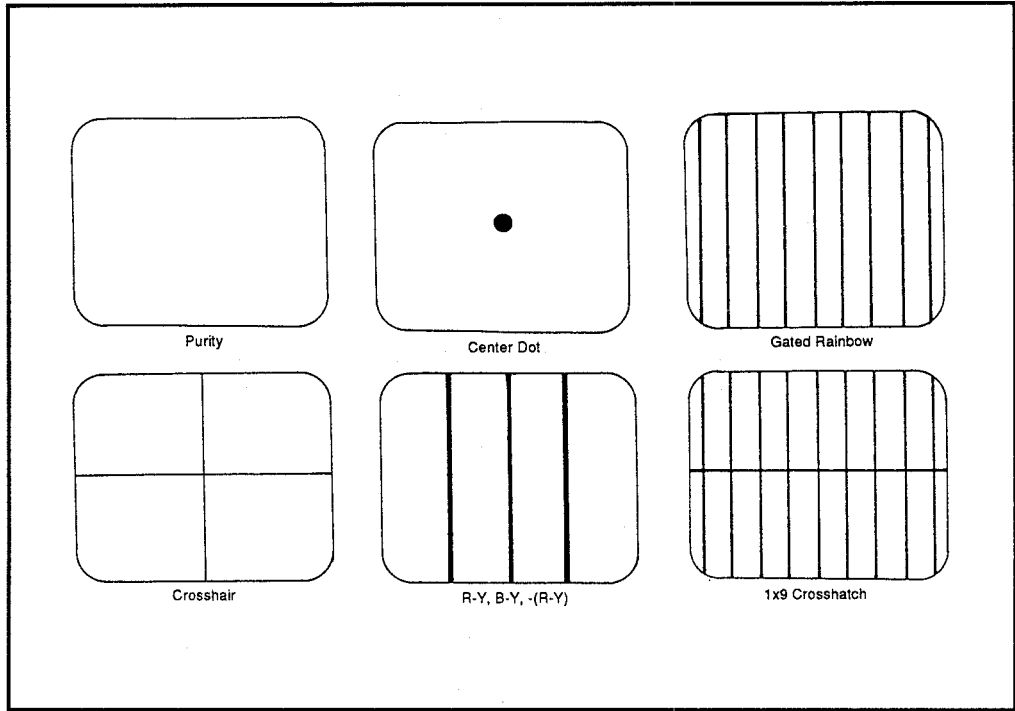


Figure 10a: Typical patterns

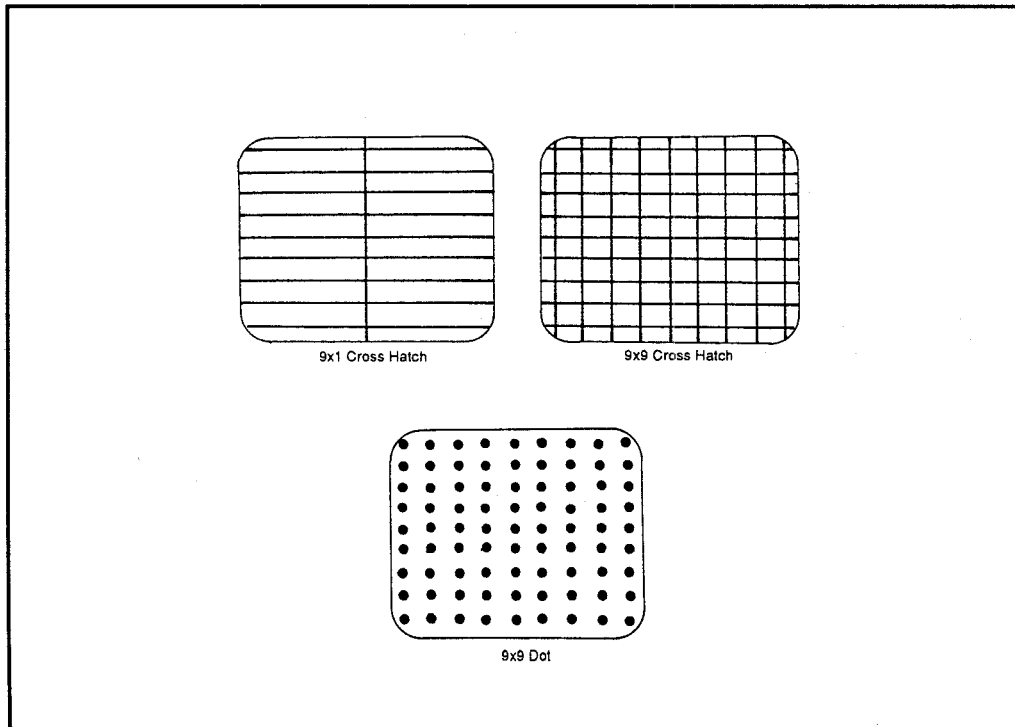


Figure 10b: Typical patterns

**6/TTV**  
Tube TV

6/TTV - TE

Test Equipment

6/TTV - TE - TV/V

Specialized TV &amp; Video Servicing Equipment

contrast one can get a satisfactory image even if the unit is not operating properly. By using a vectorscope and/or a waveform monitor, you can be sure the signal is correct.

Vectorscopes and waveform monitors are available as stand-alone instruments or as combination units. When applicable for demonstration in this manual, we shall try to convey the proper way to use these units.

### Pattern Generators

The pattern generator can create color-bars, white dot patterns, and crosshatch patterns. All of these are necessary when aligning and/or repairing television and video equipment. This particular instrument provides a chroma frequency of 3.579545 MHz. This frequency conforms to the NTSC standard and provides true primary and complementary colors at full saturation and brightness. Figure 10 shows the typical patterns generated by such a device.

These patterns can be used to check color purity, static convergence, dynamic convergence, linearity, color processing circuitry adjustments, and automatic frequency and phase control circuitry (AFPC).

A blank raster checks color purity. Dot patterns are used for convergence. Crosshatch patterns and other types of line patterns are used for linearity adjustments. When crosshatch vertical and horizontal lines are of equal brightness, the receiver's fine tuning is known to be adjusted properly. Color bars would be used to check for faults in the color processing stages.



Figure 11: Picture tube tester

**6/TTV**  
Tube TV

6/TTV - TE

Test Equipment

6/TTV - TE - TV/V

Specialized TV &amp; Video Servicing Equipment

### Color Picture Tube Tester

A picture tube tester is used to check the operation of a picture tube. Figure 11 shows a picture tube checker. The picture tube tester is used to apply test voltages to the picture tube heaters and control grids. In many cases if the tube is found to be bad, replacing the television is the best method.

If there is a problem with a picture tube, it is sometimes possible to rejuvenate a tube temporarily by applying higher than normal voltages with a picture tube tester. Problems that may be fixed by excessive voltages applied to the picture tube are: open heaters, poor electron emission characteristics, unbalanced gray scale tracking, shorted connections between picture tube electrodes, and open connections between picture tube electrodes. If the problem is with the open heater connections there is no repair possible and the unit should be replaced.

### Color Test Jig

A color test jig is used in conjunction with a picture tube tester. It consists of a substitute picture tube and yoke and includes an anode kilovolt meter. Drive signals from the unit being tested are sent to the picture tube heater, cathodes, and grids. There are several special adaptors which connect the color test jig to the unit being tested.

The use of a color test jig eliminates any uncertainty one may have about a picture

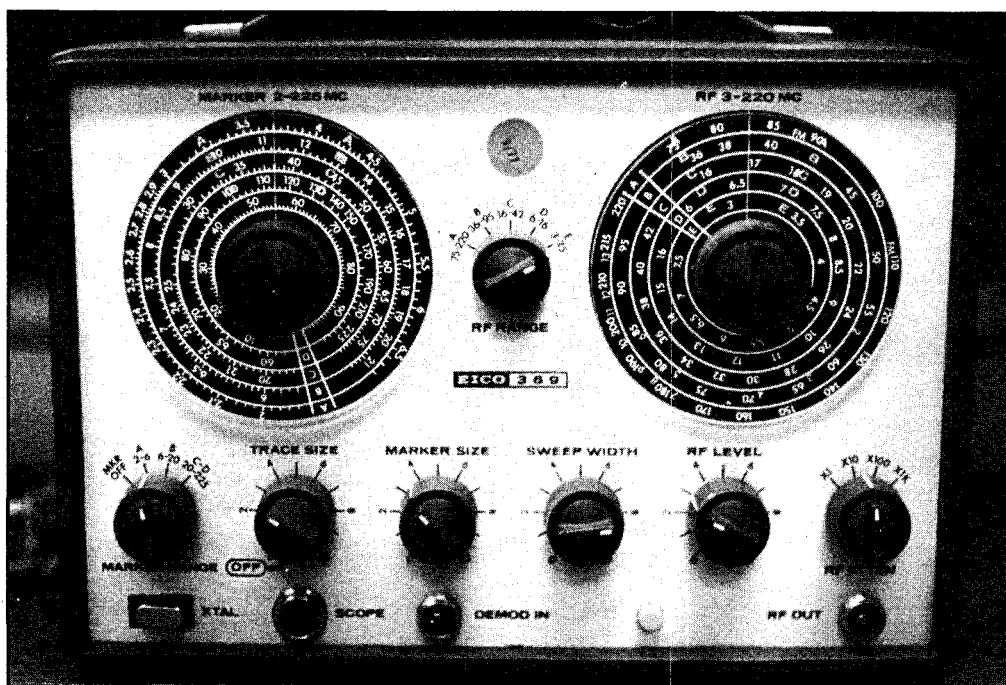


Figure 12: Sweep generator

tube's operation. It will also eliminate the many hours and dollars that may be spent trying to locate problems within a television receiver.

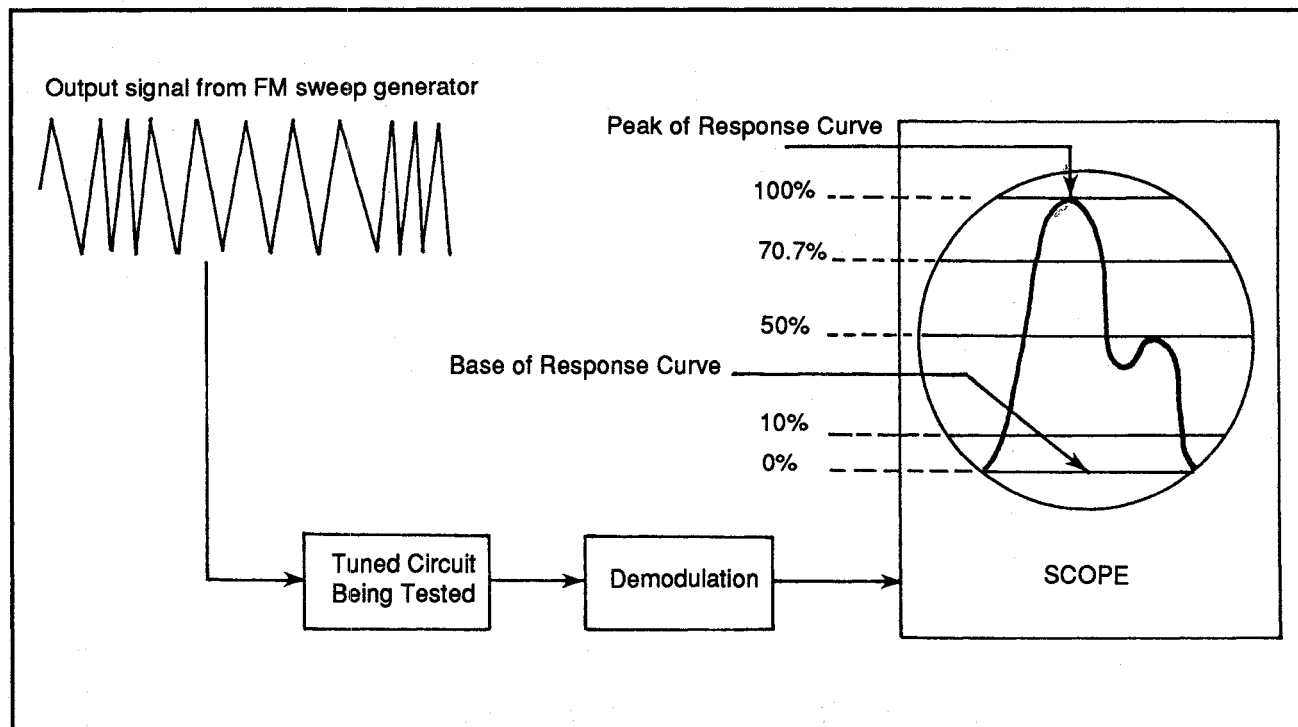
**Sweep Generator**

A sweep generator is used along with an oscilloscope to test and align the tuned circuits in the signal channels of a television receiver. It is capable of creating VHF, video-frequency and IF outputs. By using the harmonics of the VHF output, the UHF tuner can be swept as well.

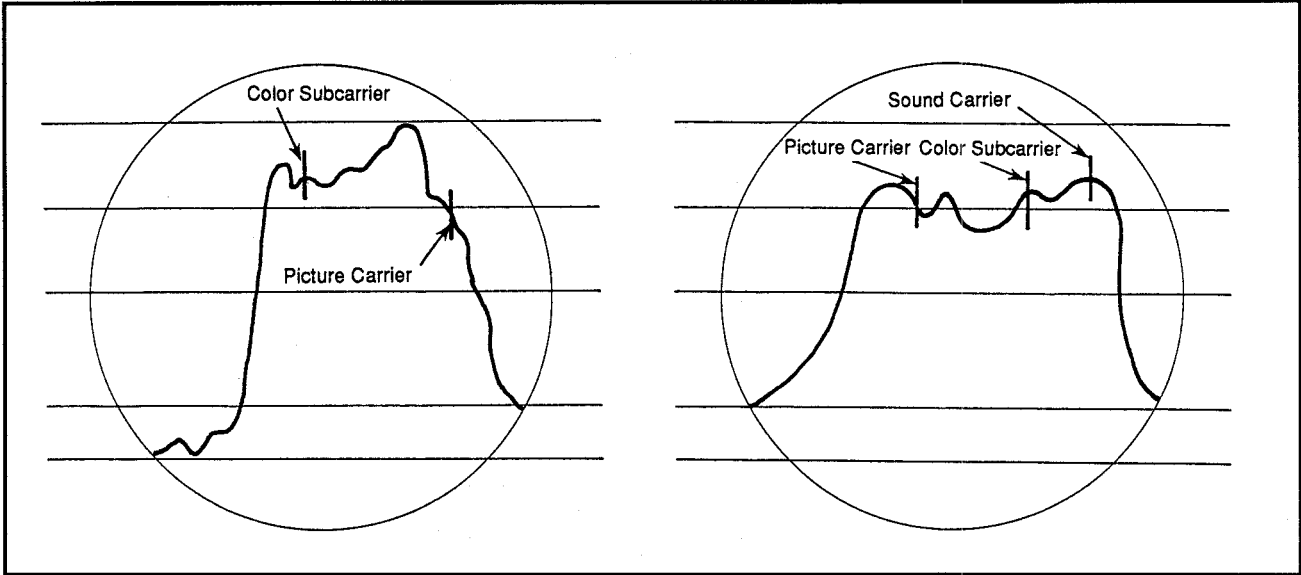
Figure 13 shows the basic principle of sweep alignment. Applied to the tuned circuit under test is an FM signal with appropriate center frequency and deviation. Tuned circuits have certain frequency characteristics for which the demodulated output appears on a scope screen as a plot or graph of the output voltage as opposed to frequency.

Within the curve may be beat markers from the sweep generator's marker circuitry. A beat marker signal is mixed with the sweep signal after the signal has passed through the receiver circuits.

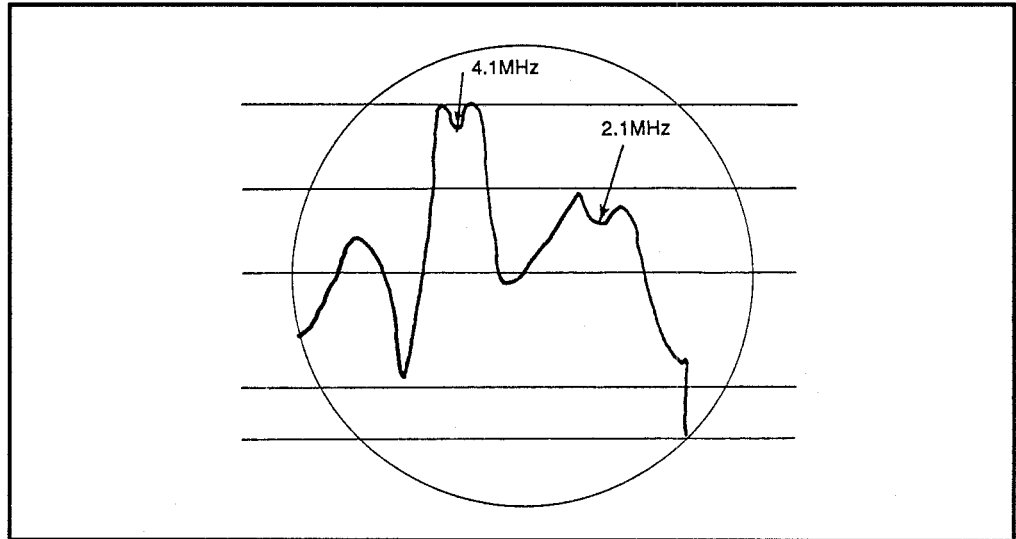
The marker amplitude displayed on the scope screen is independent of the



**Figure 13:** Basic principle of sweep alignment



**Figure 14:** Waveform with beat markers



**Figure 15:** Absorption markers and their characteristic "dips"

signal attenuation or amplification that occurs in the tuned circuits being tested. Some sweep generators provide single markers, while others provide multiple markers. Figure 14 shows a waveform with beat markers. If absorption markers are used, they will appear as "dips" along the response curve, as shown in Figure 15.

# 6/TTV

## Tube TV

6/TTV - TE	Test Equipment
6/TTV - TE - TV/V	Specialized TV & Video Servicing Equipment

### Test Charts

Aside from the use of electronic test equipment which can be costly, a cheaper, more desirable method of testing television and video equipment is the use of a test chart. Pattern generators tend to generate these patterns electronically. A variety of test charts are available.

The EIA Color Registration Chart is used to aid the alignment and testing of the pick-up device of a video camera. It could also be used in checking a monitor/receiver performance via input from a good working camera. This chart has very fine horizontal and vertical black lines on a white background which allow for very accurate alignment of the optical and electrical camera systems.

The EIA Resolution Chart is used to measure the resolving power of a system under test. The chart is sent to a monitor/receiver via a camera. Adjusting relative to the scanned area, the horizontal and vertical resolution wedges cover the range from 200 to 800 television lines. The chart may or may not have gray scales. The gray scales are designed to provide logarithmic reflectance relationships. The chart can be used to check resolution, scanning size, linearity, aspect ratio, focus, focus uniformity, shading, transient response and low-frequency phase shift.

The EIA Logarithmic Reflectance Chart has two crossed, nine step gray scales on a 12% gray background, with the scale steps showing a logarithmic reflectance progression from 3 to 60%. Between the two gray scales is a black swatch which is used to calibrate the absolute black of an item. This chart is used to check a camera's transfer characteristic.

The EIA Linear Reflectance Chart is virtually identical to the Logarithmic Reflectance Chart except the two gray scales have a linear relationship to each other.

The EIA Linearity Chart, or Ball Test Chart, is used to test geometric distortion of the camera chain. The inner and outer diameters of the circles are equivalent to 1 and 2% of the picture height. The chart pattern frequencies to be matched are 315 kHz for horizontal and 900 Hz for the vertical directions.

The White Pulse Chart or Window Chart pattern consists of a white box against a black background. It is designed to produce a full dynamic range square pulse on a waveform monitor. The chart is used to adjust image enhancement mechanisms and check system rise times and transient response.

The Color Calibration Chart has three horizontal bars on a black background. The center bar is at a constant 60% white level with the other two bars consisting of



---

6/TTV - TE	Test Equipment
6/TTV - TE - TV/V	Specialized TV & Video Servicing Equipment

---

the six saturated colors representing the hues of the NTSC primaries and their complements. When displayed on a vectorscope, these colors will fall within the tolerance boxes when properly calibrated.

**Conclusion**

Appropriate test equipment and test charts can align equipment properly. Ideally, one should have most of the equipment listed in this section, in addition to standard test equipment. Practically, it is expensive to have everything, so choosing the equipment for your specific needs is difficult.

The latest and cheapest alternative to having a wide variety of specialized television test equipment is to purchase a PC card to be inserted in your personal computer, whether it be an IBM, MAC or Amiga system. Such a card enables the use of waveform, vectorscope and pattern generator for under a thousand dollars.



---

## 6/TTV - TR

### Troubleshooting and Repair

---

## 6/TTV - TR - A

### An Introduction

---

A basic troubleshooting flow chart is shown in Figure 1. To begin troubleshooting, one must decide where the problem is occurring. There are three primary areas in which the problem may be found.

- Picture reproduction is unacceptable
- Sound is unsatisfactory
- Both picture reproduction and sound are unacceptable

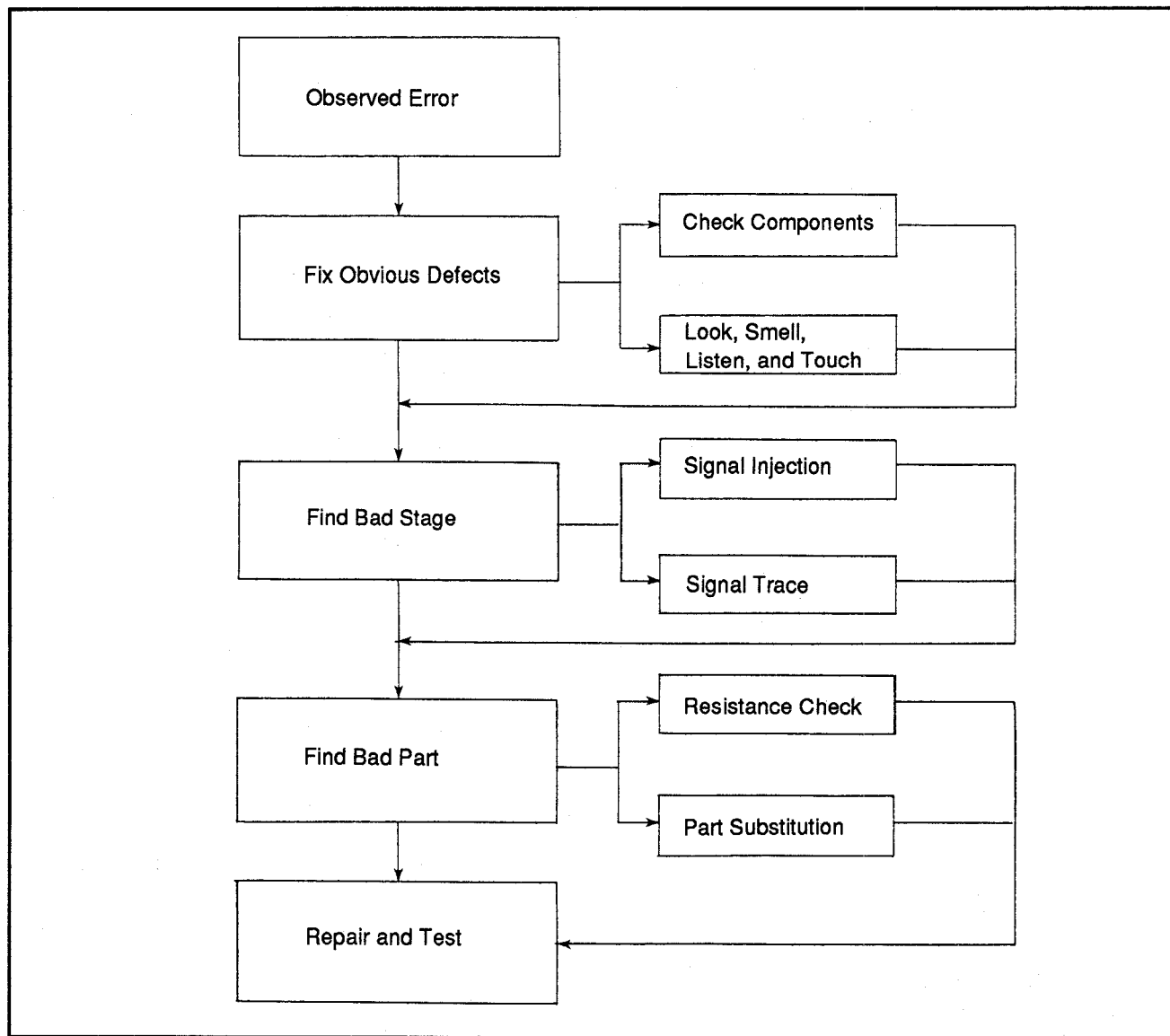
#### Picture Problems

For example, if the picture is the best it has ever been, but the audio output is not what it should be, the problem is not in the video circuitry. Likewise, if the picture rolls but the sound is good, you can be sure the problem is in a part of the video circuitry and not the audio sections. If both video and audio signals are weak, most likely the problem occurs in the signal channel before the sound removal point.

Picture problems suggest that the fault lies in one of three possible areas. These are determined easily by feeding a color-bar pattern into the receiver and viewing the picture.

When normal, you will see a normal set of color bars. If the color reproduction is normal and the black-and-white images are absent or distorted, the problem is due to the lack of the Y component of the signal. The hues will appear dull or muddy, with the absence of black-and-white images. However, if the color portion is absent or abnormal and the black-and-white picture is normal, check the chroma section and not the black-and-white section. The hues of the color bars will be shifted or lack chroma. When both are causing problems, the fault will lie in the signal channel prior to the chroma-takeoff point. The hues will be shifted in phase and the Y component missing.

These problems may be illustrated in a color-bar comparison chart that accompanies your pattern generator.



**Figure 1:** Television troubleshooting flow chart

Picture troubles include:

- Low or excessive contrast
- Low or excessive brightness
- Poor focus, excessive snow
- Smearing
- Ghosting (continued next page)

- Off-center raster
- Negative picture
- Ringing
- Poor sync action
- Incorrect hues
- Color impurity
- Misconvergence
- Interference
- Miscellaneous intermittent conditions

If there is a fluctuation or instability of either the picture or the sound reproduction, the problem is between the intermittent and normal operation.

### Testing Procedures

Suitable testing is required to identify and locate a particular problem in a receiver. This testing can be done by either signal tracing procedures, or by signal substitution procedures. Signal tracing is done with the oscilloscope and the signal injection instrument. TV service manuals supply the necessary waveforms and their peak-to-peak voltage values that are found at key test points.

Signal tracing involves locating signals at these test points. A distortion in the waveform and/or improperly displayed peak-to-peak voltage indicates the problem lies within the circuit being tested. An oscilloscope and an appropriate signal injector are used for signal tracing.

A specific receiver service manual has the desired waveform patterns shown for comparison to those you are finding. Also provided are the peak-to-peak voltage values found at key test points in the receiver system. Signal tracing involves waveform checking at these points with an oscilloscope and appropriate pick-up probe. If an incorrect waveform or peak-to-peak voltage is found, it could indicate that the section under test is the section with the problem.

Signal injection allows the receiver's picture tube to be used as the indicator. A certain pattern or signal is injected into the system and viewed on the picture tube. Where there is a problem displayed from the first connection of the main input, you would continue inserting an appropriate test signal, circuit by circuit. An appropriate signal would be something like a color-bar pattern, or a black-and-white test pattern.

### TV Standards

Most of the information provided in the television repair section applies whether the unit is black-and-white or color. What you see on a screen came from a composite signal that carries both the sound and video components required to reproduce an acceptable image. Present-day television standards are based on the

National Television Systems Committee (NTSC) standards established in 1953. These standards are used throughout the United States and have been adopted by other countries including Canada, Japan, and Mexico.

Other countries use different systems. France and the Commonwealth of Independent States use the *Sequentiel Couleur avec Mémoire. Phase Alternation Line (PAL)* is used by many European countries including the United Kingdom and Germany.

The NTSC standard maintains a compatibility with existing black-and-white receivers. Monochrome television channels are allocated a 6 MHz bandwidth and the color has to fit within this range. In the near future this may change from 6 MHz to as high as 30 MHz when high-definition television becomes more readily available. Figure 2 shows the television frequency spectrum graph. Note the luminance signal sidebands occupy a signal on either side of the picture carrier.

When the need to keep a compatible system arose, broadcast signals were looked over carefully. Energy in a broadcast signal is not evenly distributed throughout the bandwidth.

There are groupings that occur, called clusters, which tend to appear at certain

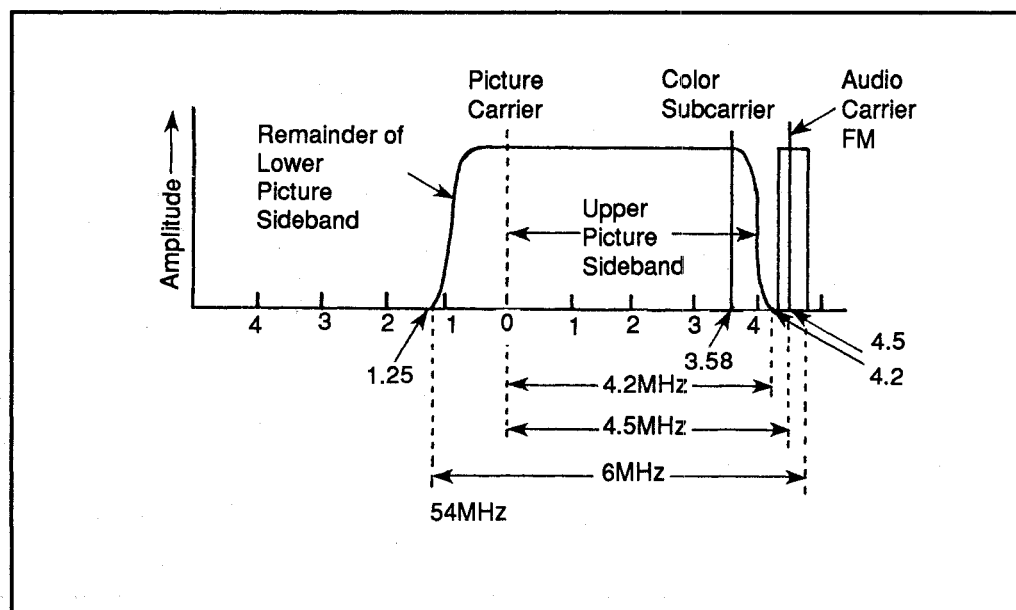


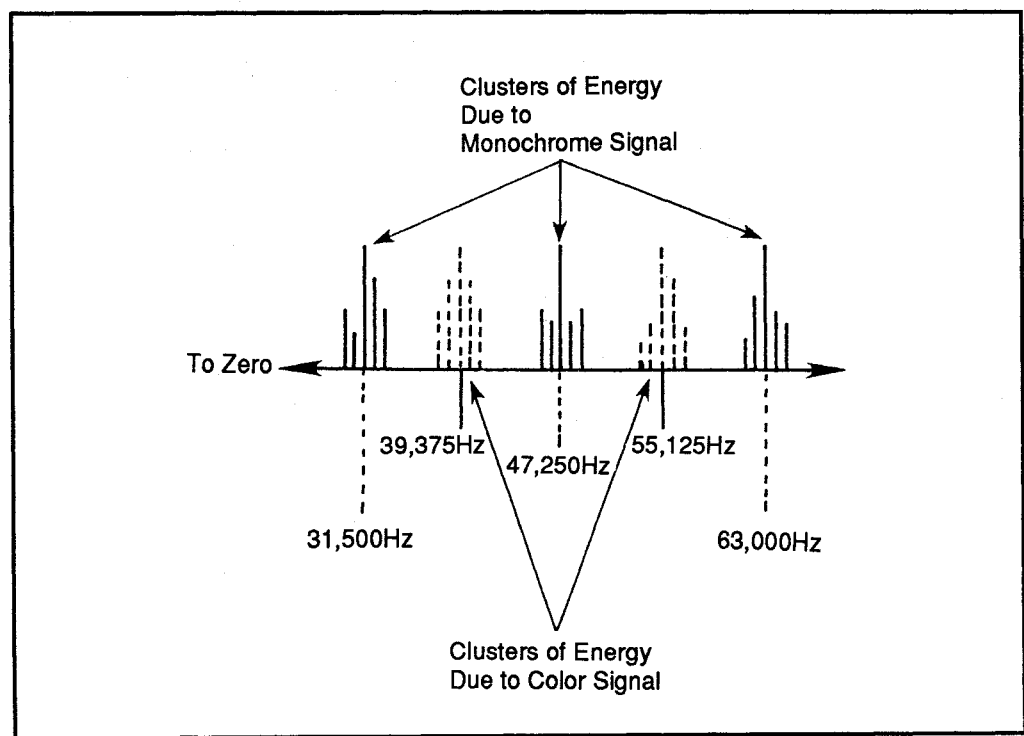
Figure 2: Television frequency spectrum

harmonic intervals of a basic carrier frequency. These clusters in a 4 MHz monochrome video signal appear at harmonic multiples of the basic scanning frequency. In a monochrome signal there are 525 lines of resolution occurring 30 times a second or a scanning frequency of 15,750 Hz.

Each energy cluster occurs at intervals separated by 15.75 kHz within the 4 MHz bandwidth. This is illustrated in Figure 3.

This space between can be used for color signal information and thus the NTSC color information signal is multiplexed, or placed evenly between the monochrome signals. Both a color and monochrome signal will then be multiplexed within a 6 MHz bandwidth.

Figure 4 shows the block diagram of the basic color receiver. There are ten processing stages to produce a picture: RF tuner, video IF amplifier, sound IF, video detector and amplifier, chrominance section, color synchronization section, synchronization separators and AGC circuit, high voltage circuits and the color picture tube and convergence circuits.



**Figure 3:** Insertion of color signal between monochrome clusters

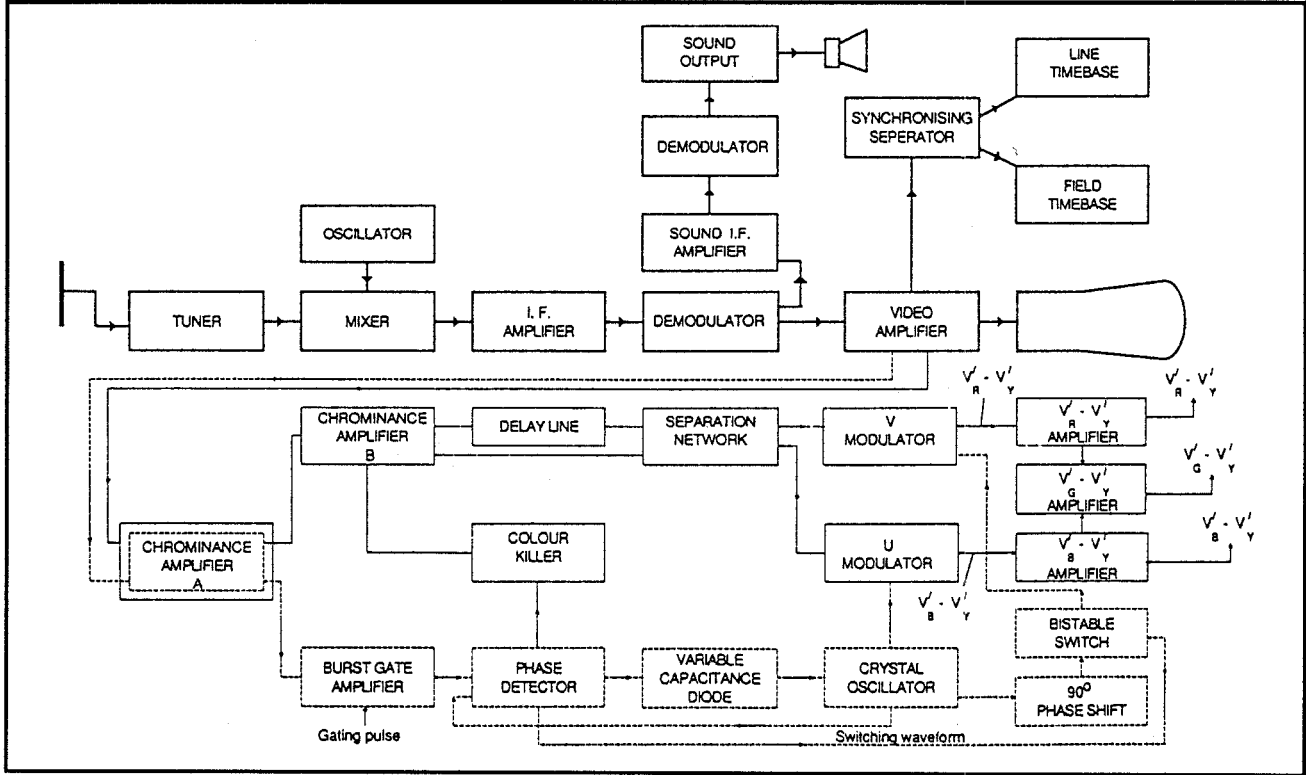


Figure 4: Block diagram of a television receiver

---

## 6/TTV - TR

### Troubleshooting and Repair

---

## 6/TTV - TR - AS

### Audio Section

---

Television audio in a composite video signal is transmitted through the use of frequency modulation (FM). The FM sound is transmitted at 25 kHz below the upper end of the video channel bandwidth. The upper limit for sound is then allowed at the upper limit of a television bandwidth. FM sound for television has an audio bandwidth from 50 Hz to 15 kHz and is transmitted at 4.5 MHz above the RF picture carrier.

The sound carrier travels through a detector to create the intermodulation beat of 4.5 MHz. The intercarrier sound signal is then amplified, limited, and FM demodulated to recover the audio.

Sound IF amplifiers within television receivers have a bandwidth of 50 kHz, centered at 4.5 MHz. Sound IF amplifiers operate with a smaller bandwidth than video IF amplifiers. For the most part, the two sections operate in similar fashion.

Audio travels with sound to the IF stages and is then removed at one of the IF stages. Figure 1 shows a block diagram of a receiver IF processing section. To keep the sound carrier from heterodyning against the video IF, which would cause a 0.92 MHz beat frequency and interference, sound traps are employed. Sound traps reduce the sound carrier to about 5 percent of the video IF amplitude. More than one trap may be employed. The most widely used trap in color receivers is the bridge-T trap. Bridge-T traps employ a resistor to attenuate the signal amplitude. Attenuation factors of 50:1 or 60:1 can be achieved with a bridged-T trap. Any unwanted frequency passing through the trap is reduced to 1/50th or 1/60th of the input amplitude values.

A more efficient trap is a delta, or Y transformation trap. The impedance values  $Z$  are chosen carefully to create  $Z_1$  of a negative value. The total impedance between points 1 and 2 will be zero if  $R$  is equal to  $Z_1$ . Any undesired frequency is completely eliminated.

Removal of the sound IF is done by the intercarrier sound system. Figure 1 shows a block diagram of this type of circuit. The sound IF is removed by the sound traps. If not removed, a herringbone interference pattern will occur in the video image. The 41.25 MHz sound IF is sent to a sound IF detector.

Output from the sound detector is the 4.5 MHz intercarrier sound IF. This signal is then applied to the sound IF amplifier. The sound IF amplifier increases the signal strength to between 2 and 5 volts so it is able to drive the sound IF limiting circuit.

The sound IF limiting circuit removes an AM interference that tends to increase the amplitude of transmitted signals. Also the center FM frequencies tend to increase in amplitude. An AM signal found in the FM signal will cause a distortion of the modulated sound information. Limiters remove the AM interference from the FM signal. After being limited, the 4.5 MHz sound IF is sent to an FM sound detector for demodulation. The demodulator restores the original modulating information.

### Demodulators

The FM sound detector demodulates the 4.5 MHz sound IF and restores the 50 Hz to 15 kHz audio information. Modulating causes the FM carrier frequency

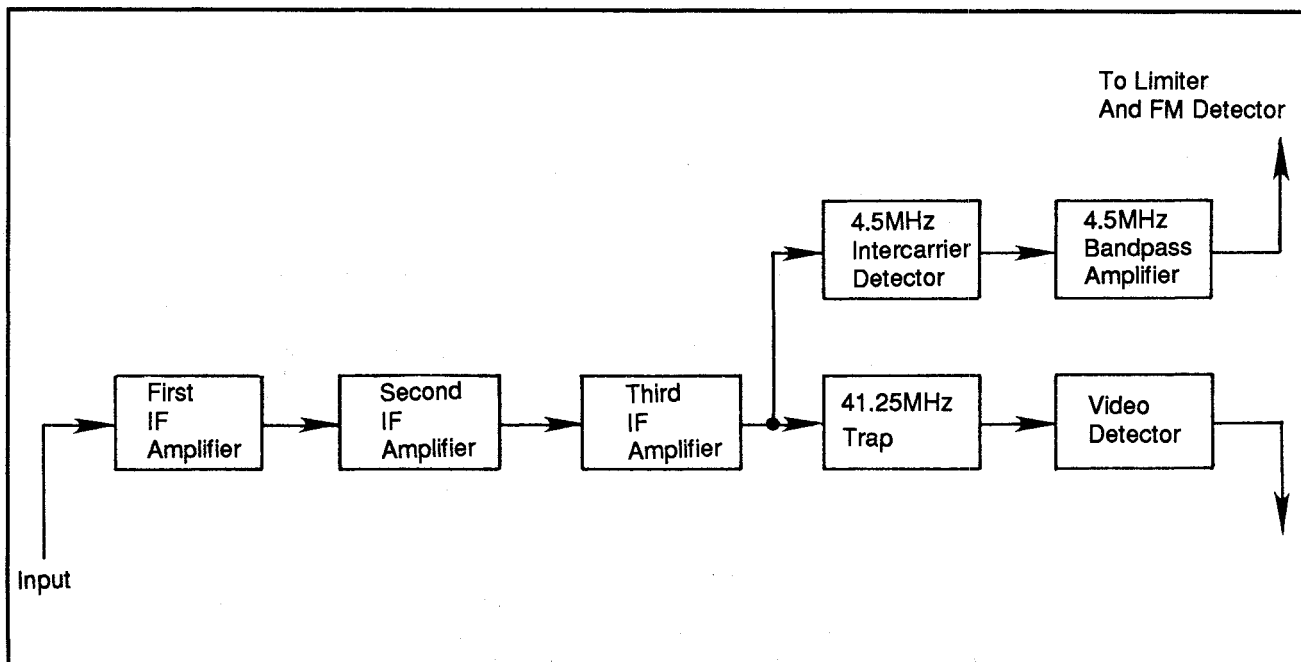
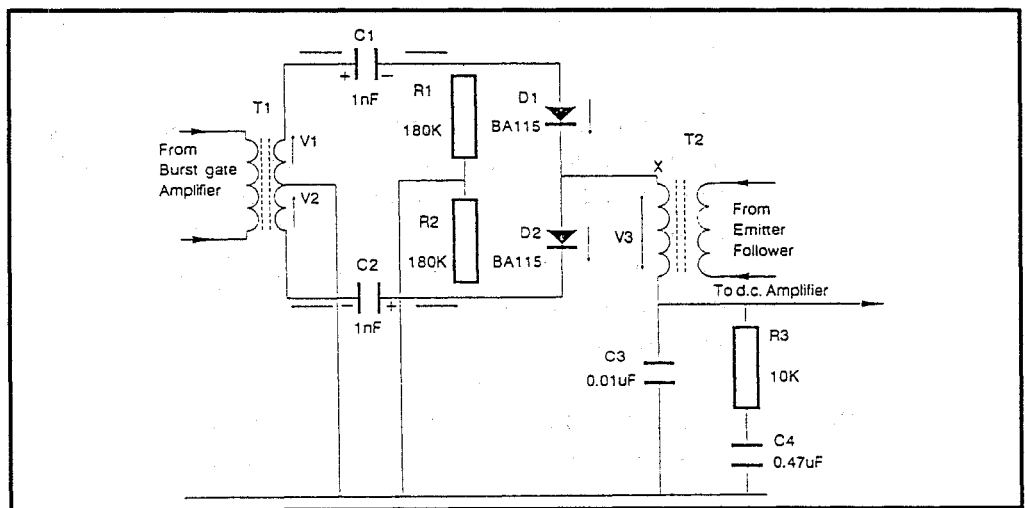


Figure 1: Block diagram of an intercarrier sound system

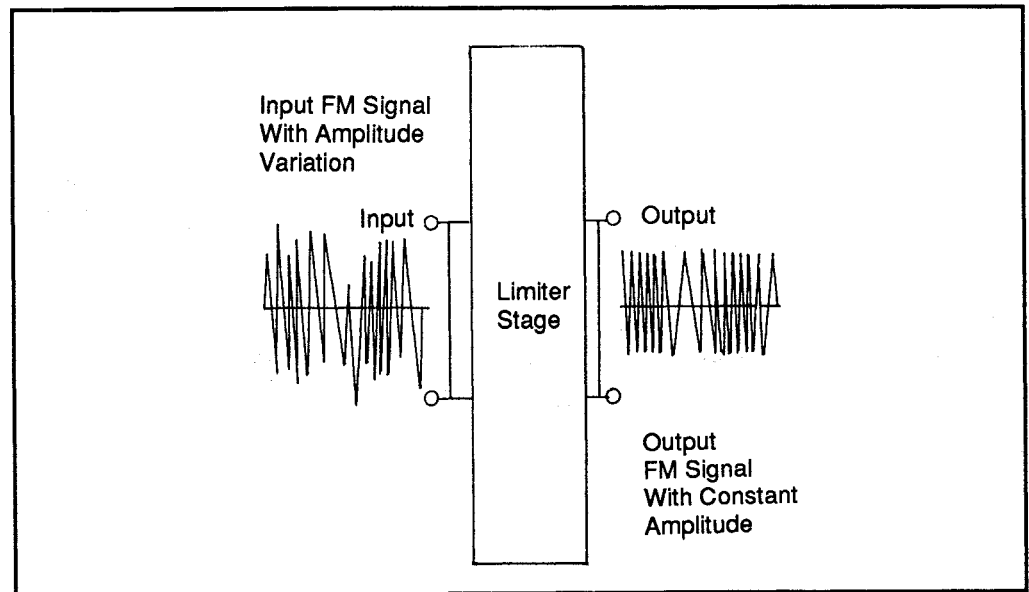


to modulate from the center frequency at rates equal to the modulation frequencies. The sound detector then recovers modulating frequency information from the rate of deviation. The amplitude of modulating information is obtained from the amount of deviation from the center frequency.

A discriminator circuit is one type of FM sound detector circuit used to generate



**Figure 2:** Phase-shift discriminator circuit



**Figure 3:** Essential action of a limiter stage

frequency voltages. Figure 2 shows a phase-shift discriminator circuit. Parallel or series resonant circuits may be used in FM discriminators. Both circuits can have capacitive and inductive elements equalized at specified frequencies. A discriminator will take an input FM signal with amplitude variation and output it with constant amplitude as shown in Figure 3.

### Discriminators

Discriminators require a deemphasis circuit in the audio output section. FM transmissions are preemphasized at the TV transmitter end in order to allow for an optimum signal-to-noise ratio at the receiver. These signals must then be deemphasized to produce proper tonal balance. Figure 4 shows a circuit that would be used to apply deemphasis to a signal from the FM detector. In an IC-based circuit, this function may be a part of the FM detector, demodulation chip.

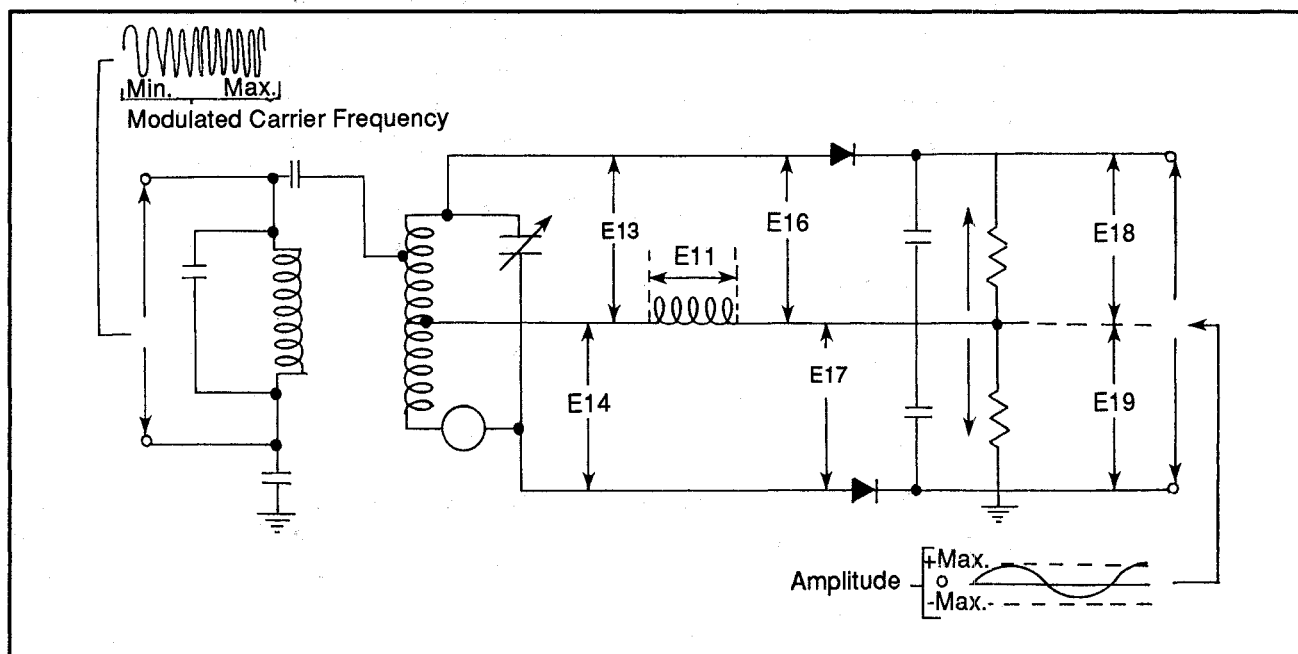


Figure 4: Discriminator circuit

### Ratio Detectors

A ratio detector is a form of FM detector that creates audio output in response to the ratio of two developed voltages. In such a circuit, each diode has a completely separate resonant circuit. The resonant frequency of each diode circuit agrees with the ends of the FM IF band. Two output voltages E1 and E2 are found to be equal when the 4.5 MHz is applied through the coupling transformer. If a lower frequency IF voltage is applied to the circuit, E2 will be greater than E1. If a higher frequency IF voltage occurs, E1 will be greater than E2.

Any positive or negative signal at an IF frequency other than the center 4.5 MHz will cause an output audio voltage across the resistor R1. When E1 is not equal to E2, the output voltage is sent to the base of the audio amplifier stage via R1. Any amplitude variations present in the signal cannot pass.

**Phase-Lock Loop  
Detector**

A PLL circuit uses a variable oscillator to copy the frequency and phase angle of a reference frequency. The phase detector compares the reference frequency with the oscillator frequency. Phase differences produce error signals which indicate the variation from the reference signal. The error signal represents the modulating audio information.

**Audio Section  
Repair**

Audio troubles will seldom cause problems in the video picture. Usually if there is a problem in the video related to the audio, the problem will occur before the sound is removed and processed by audio circuits. When normal pictures are being created with poor audio, the problem occurs between the sound take-off point and the output or speaker. Audio problems could involve a complete failure of sound, an inadequate level, distortion, or possible buzzing.

For all but buzzing, the problem will be found in the audio processing circuits. Buzzing is usually caused by a defective tuner, IF amplifiers, video amplifier, or the audio processing section.

Finding audio problems is easiest with the use of a wide-band oscilloscope and a low-capacitance probe. The receiver must be set to a suitable station, or a suitable generator must be providing a signal to trace.

In a normal receiver operation, a 4.5 MHz sine wave pattern is displayed on the scope screen at the input terminal of the intercarrier sound IF amplifier. This signal may vary to a slight degree if not using a signal generator as the source input.

A normal signal amplitude will be about 0.2 V. Each stage up to the FM detector can be checked for the presence of the 4.5 MHz sine wave. If the signal is gone, or substantially attenuated at a particular stage, it will indicate that a defect is within the current testing area.

A buzzing signal will be displayed on a scope by a deep downward modulation or notch. There will be an amplitude modulation by the vertical sync pulse. In excessive sync-buzzing, it is possible that one of the video-amplifier stages is operating in a nonlinear fashion. An overloaded video IF stage or an overloaded

RF stage may cause buzzing to occur. Nonlinear operation will usually be caused by a leaking capacitor or a defective transistor.

Receivers built after 1975 contain very few discrete components. ICs replace major functions of various circuits. Fixing these usually requires replacing defective chips and often complete PC boards.

The first step should be a visual inspection of the problem area. ICs, if socketed, can become loose over time and need to be resealed to work properly. For this, don't just rely on your eyes. With the power off, gently push down on every socketed IC. Look for cracked PC boards, and for areas or components that are burned, leaking, or have an odor.

In case of a nonexistent sound signal, use the oscilloscope to trace the 4.5 MHz signal to the point where it stops. A defective capacitor can cause this to happen. A leaky capacitor can cause a transistor bias to be out of its operating range, and an open neutralizing capacitor can bias a transistor out of its operating range.

After the defective stage is located, DC voltage measurements are generally the most effective way to locate the bad part. In the case of an IC, replacing the entire PC board may be the only way to fix the problem.

Noisy sound output is caused by insufficient limiting. Again, the problem could be a leaking capacitor at the output of the ratio-detector circuit or discriminator circuit. Older capacitors will tend to lose a substantial portion of their rated capacitance and will need replacing. Checking capacitors with a capacitance checker, or replacing a suspected capacitor is best. Also, defective transistors may cause excessive noise, so if the capacitors are correct, try checking the transistors.

## 6/TTV - TR

### Troubleshooting and Repair

## 6/TTV - TR - BA

### Bandwidth Amplifier

#### Color Problems

The bandwidth amplifier can cause lack of color, washed-out color, excessive color levels, or color smearing. A total lack of color will result in a monochrome picture. Check to see if there are any damaged ICs or transistors, broken wires, or improper adjustment of the color killer or AGC.

Figure 1 shows samples of waveforms that may be found before and after a bandwidth amplifier. By checking both sides of the bandwidth amplifier with an oscilloscope and color-bar generator, one can determine if the problem lies within the bandwidth amplifier. The manufacturer's service manual will give the proper specifications for waveforms and amplitudes.

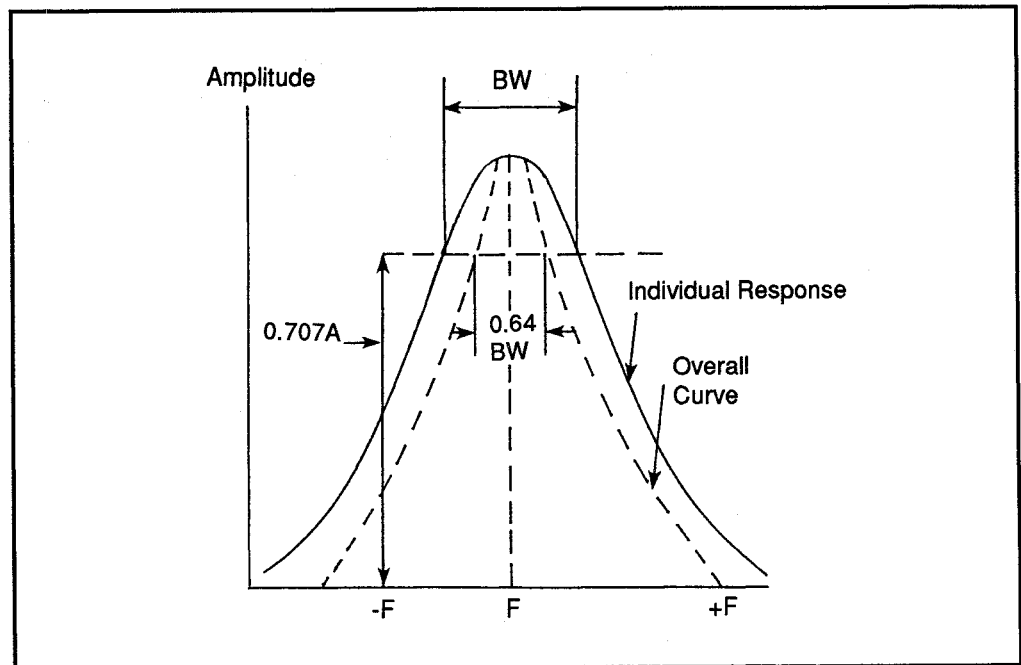


Figure 1: Bandwidth amplifier waveforms



---

6/TTV - TR

Troubleshooting and Repair

---

6/TTV - TR - BA

Bandwidth Amplifier

---

## 6/TTV - TR

### Troubleshooting and Repair

## 6/TTV - TR - CPT

### Color Picture Tube

#### Operating Conditions

For a color picture tube to operate, voltages up to 30,000 with a maximum current of 1.5 mA are required. The focus voltage requires ranges from 5,000 V to 8,000 V. The high-voltage load must be maintained at a constant value, as great changes in beam current can affect scanning response and other picture-related operations.

#### Components

The picture tube consists of a surface coated with phosphors. Three electron beams energize separate red, blue and green phosphors on the inside screen surface. Each dot is surrounded by a barrier called a surround, which prevents the bleeding of colors with one another. The three electron beams will energize only those phosphors to which they have been assigned.

A convergence circuit and convergence magnets ensure the accurate positioning of the separate electron beams. The convergence magnets are placed around the

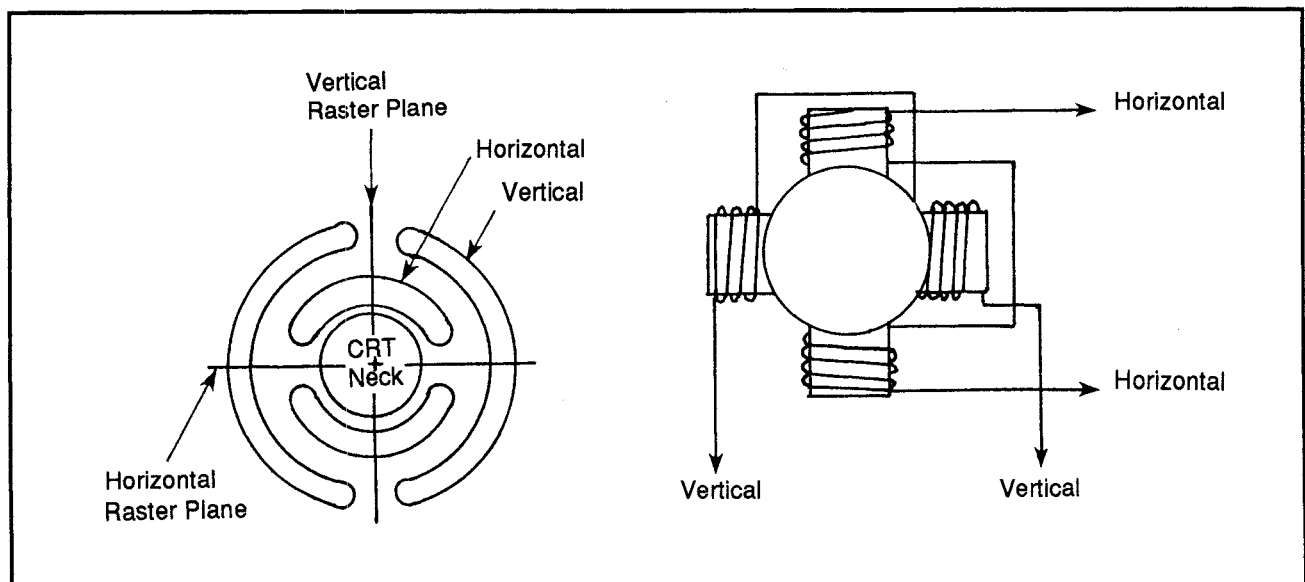


Figure 1: Toroidal yoke windings

picture tube neck and aid in minor corrections for misalignment and magnetic misalignment.

Each set of phosphors, red, green, and blue are arranged in groups of three or triads. There are more than 300,000 triads on a single picture tube. Each triad measures approximately 0.016 inches in diameter. Energizing a triad with each dot at a certain percentage will produce a color.

### Yoke

About the neck of the picture tube will be a deflection yoke which consists of two sets of coils. One set is for vertical deflection and the other for horizontal deflection. The yoke is mounted around the neck of the picture tube's smaller end, where the electron gun connections are located. When power is applied, the coils produce a strong magnetic field that deflects the electron beams. Figure 1 shows a toroidal yoke found in most color receivers.

The windings for a toroidal yoke are wrapped around a toroid, or doughnut-shaped structure as shown in Figure 1. This is a very efficient deflection yoke configuration producing a strong magnetic force with minimal loss.



## 6/TTV - TR

### Troubleshooting and Repair

## 6/TTV - TR - DC

### Deflection Circuits

#### Vertical Deflection Circuits

A vertical deflection circuit is shown in Figure 1. Problems in the vertical deflection can cause a loss of vertical deflection, improper height, improper vertical linearity, loss of vertical sync, or keystoneing. These symptoms are illustrated in Figure 2.

A loss of vertical deflection will cause a raster to be displayed in a single horizontal line. The line will be extremely bright because all information for the entire picture will be found within it. This could cause permanent damage to the phosphors of the picture tube.

To trace the problem, a signal injection with a 60 Hz input is needed. Tracing begins at the vertical oscillator output. Trace the signal through the vertical

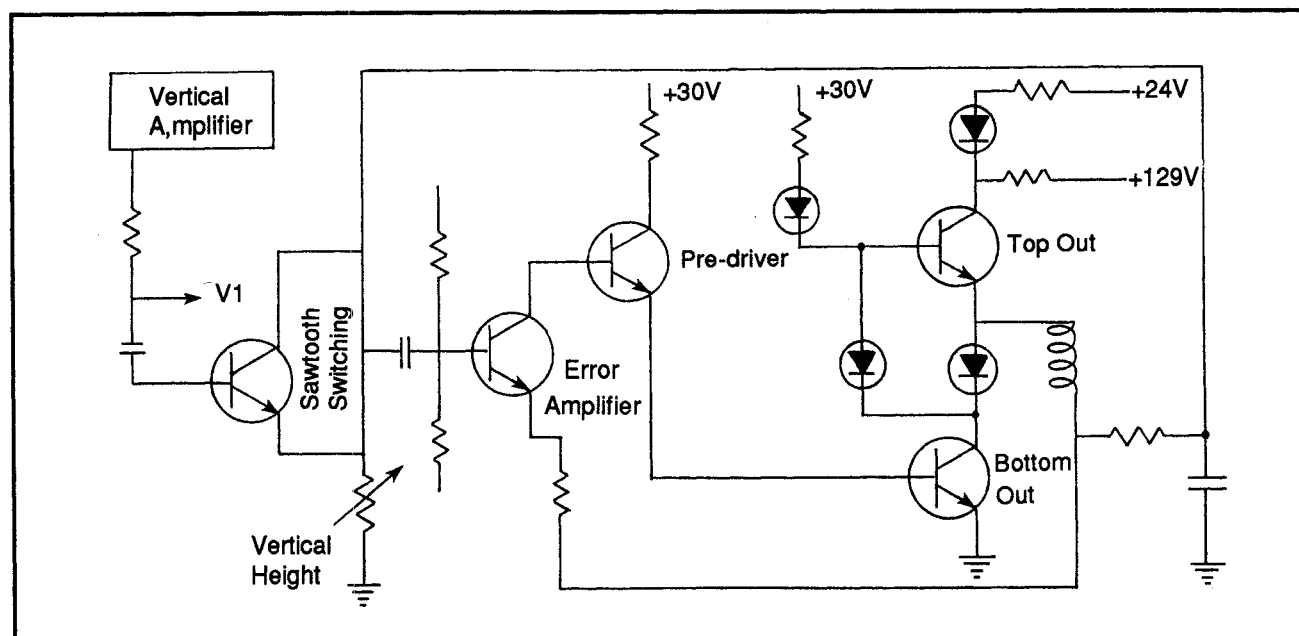
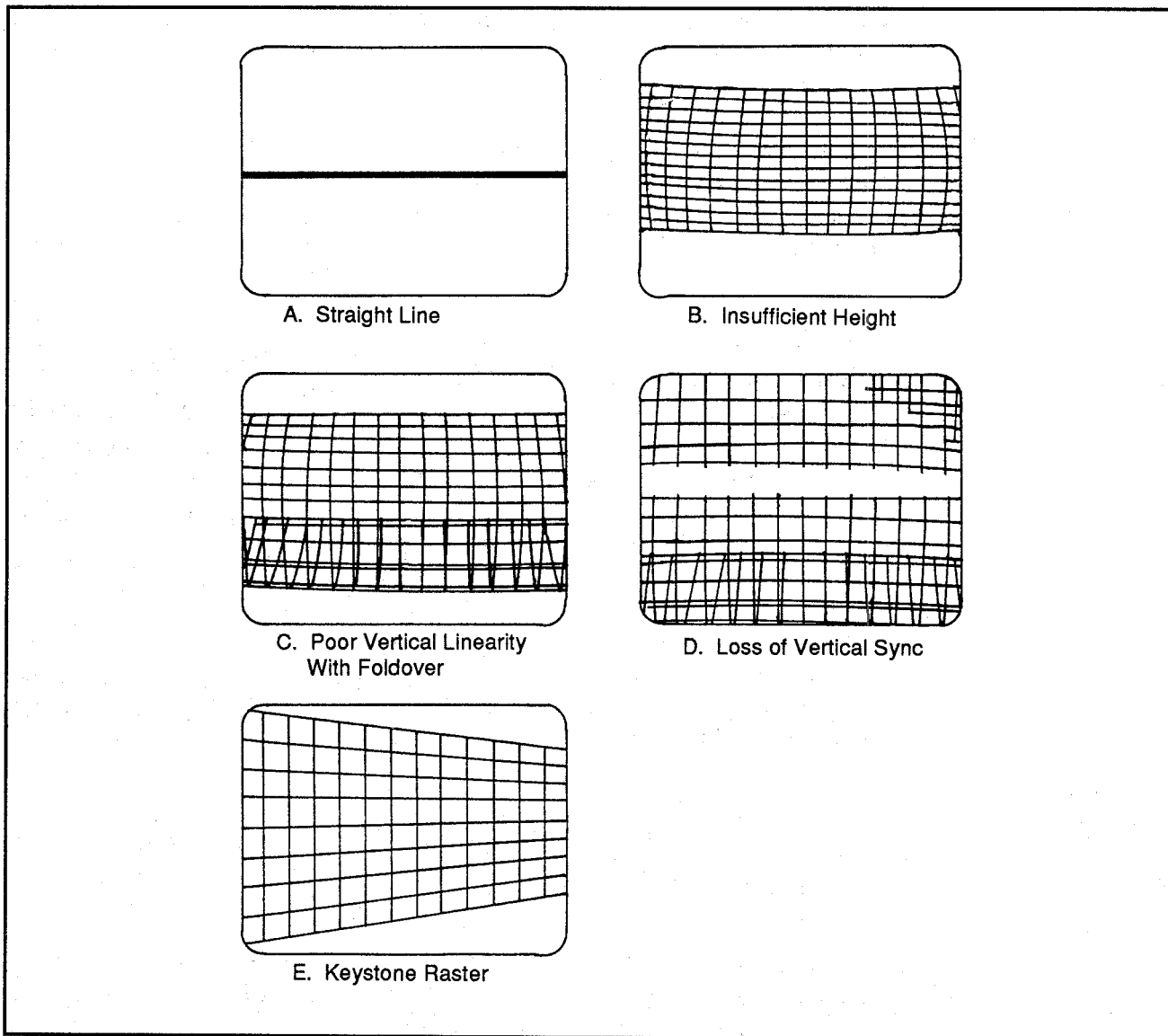


Figure 1: Vertical deflection circuit



**Figure 2:** Video problems caused by vertical deflection malfunction: (a) loss of vertical deflection (b) improper height (c) improper vertical linearity (d) loss of vertical sync (d) keystoneing

deflection amplifier. The point where the waveform is lost indicates the defective part.

Signal injection with transistor or IC stages will require a signal source with a low internal resistance and adequate output current. The source needs a DC blocking capacitor to prevent unwanted DC changes from affecting transistor operation. Signal injection begins at the output stage. A proper raster display occurs when the signal is injected. Proceed backwards through the stages to the

oscillator. When the signal does not produce a proper raster, the problem stage will have been found. Voltage and resistance checking and part substitution can then be used to fix the defective part.

A receiver with multivibrator vertical deflection circuitry that is having vertical deflection problems indicates the circuit is not oscillating. No waveform monitoring or voltage checking is possible and the section will have to be corrected by substitution.

A picture squeeze will occur if the peak-to-peak amplitude of the sawtooth waveform decreases. The overall linearity will be satisfactory, but the vertical height is less than desirable. A misadjusted height and/or linearity control could be the cause of this problem. A defective IC, shaping circuitry, or decreased amplification are areas that may cause a squeezing effect. Signal tracing can be effective with receivers that have separate vertical oscillator and amplifier stages.

Improper vertical linearity is produced by a nonlinear vertical deflection sawtooth wave. The picture may appear compressed at the bottom or top, or appear folded over, or overlapping. Improperly adjusted linearity and height control can cause vertical linearity problems, as well as a defective IC circuit, changes in transistor bias due to a leaky capacitor, changes in the RC time constant, or a defective output transformer.

### Horizontal Deflection

If the horizontal deflection circuits fail there will be no raster. The picture tube will be blank because the second anode voltage is created from the horizontal output stage. To troubleshoot horizontal deflection problems, use an oscilloscope and observe the input and output horizontal oscillator.

Horizontal oscillator frequency changes are created by several problems. Frequency changes in horizontal oscillator circuits with ringing coils may be created by open capacitors, leaky capacitors, defective coils, or misadjusted coils.

Checking a horizontal oscillator circuit with a ringing coil is done by using a jumper wire to short-out the tuned circuit. If the picture returns to normal, the tuned circuit is bad. If the problem is not fixed, each component must be checked.

Improper linearity of a horizontal oscillator includes poor picture linearity at the left and right sides of the picture. The drive lines may appear in the center and to the right of center. A defective IC circuit or transistor bias caused by leaky capacitors may be the cause. The input and output waveforms and voltages should be checked to isolate the problem.



6/TTV - TR	Troubleshooting and Repair
6/TTV - TR - DC	Deflection Circuits

The transistor and IC peak-to-peak voltages for the horizontal oscillator output range from 2 V to 20 V. A drop in voltage will cause the horizontal output to be reduced. The condition for this is a narrow, darkened image. A low supply voltage, open sawtooth capacitor or defective coupling capacitor may be at fault.



---

6/TTV - TR	Troubleshooting and Repair
6/TTV - TR - FPC	Frequency and Phase Control (Automatic)

---

Noticeable signs of phase drift may be indicated by several different responses. The 3.58 MHz oscillator may be too far off frequency to respond to control adjustments. If so, the color demodulator stages cannot produce proper output signals. An oscilloscope is needed to see if the color oscillator is producing a correct 3.58 MHz output signal. The phase detector may also cause the color killer section to malfunction.

If either the burst gate or the phase detector is defective, the DC voltage which turns off the color killer is not sent. An oscilloscope can be used to check AFPC functioning as indicated in the manufacturer's service manual.

Also, there could be a defective burst gate that does not provide a color burst to the phase detector.

## 6/TTV - TR

### Troubleshooting and Repair

## 6/TTV - TR - IFA

### IF Amplifier

The IF stages of a television signal processing section are fixed-tuned to a single IF frequency. Both the video and sound IF signals travel together through the IF amplifiers. The IF amplifiers need to have a bandwidth of at least 4.5 MHz. The bandwidth may be achieved by stagger tuning multiple amplification units. Staggering is when different amplifier circuits are tuned to slightly different frequencies allowing for a wider bandwidth.

#### Amplifier Stages

There are three or four separate amplifier stages in a color video IF processing section. Figure 1 shows a typical block diagram of a typical video IF system. By amplifying the signal in stages, the amount of distortion of IF signal waveforms is reduced. This also allows for staggered tuning to create the wider bandwidth.

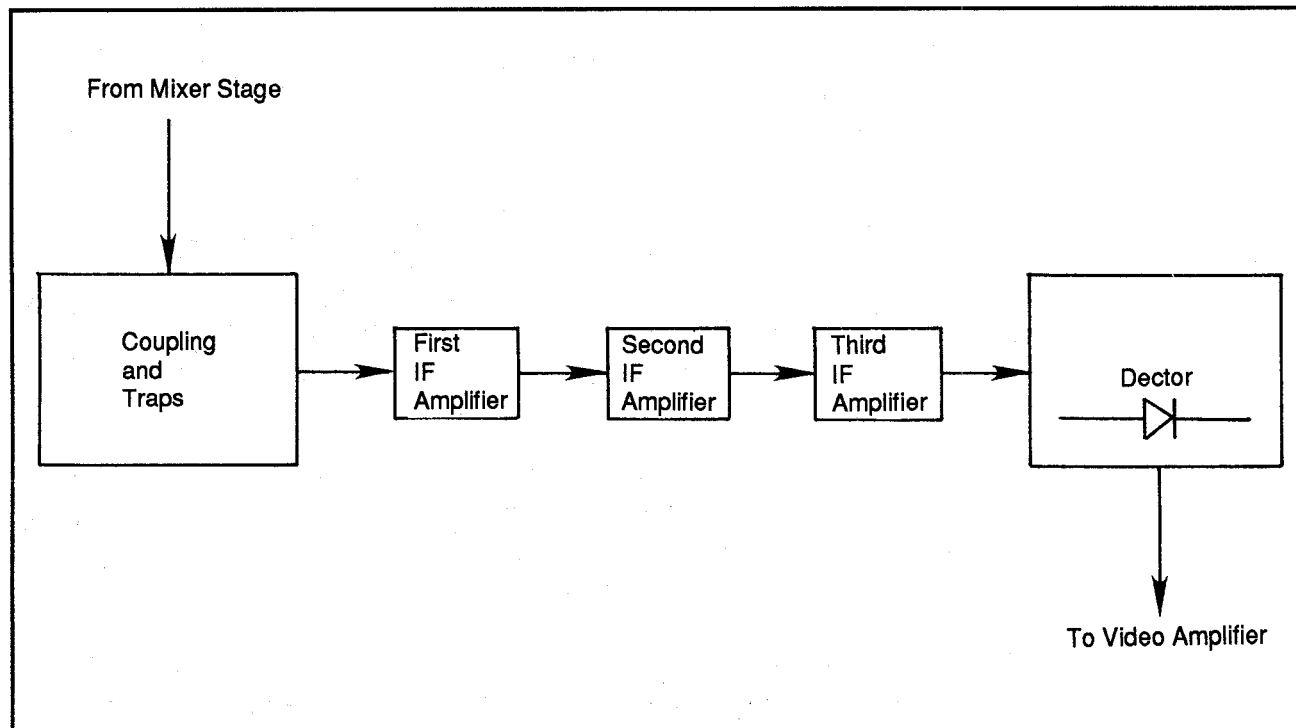
IF amplification stages range from 41 MHz to 46 MHz. Traps through the circuits are used to attenuate transmission of the video carrier of the next higher channel, sound carrier of the current channel, and sound carrier of the next lower channel. The attenuation of adjacent channel information is usually in the range of 55 to 60 dB.

To ensure that the color subcarrier and all the related sidebands are included, the IF frequency response curve is about 4.3 MHz wide at the 50% amplitude points.

#### Selectivity

The most important feature of the IF amplifier is selectivity. Selectivity is the process of allowing only the desired frequencies to pass while rejecting all others. Connected to the last video IF amplifier is the video detector processing stage. In this stage, the video carrier signal is heterodyned against its sidebands. The resulting beat frequencies are made of the original modulating information.

After video detection, the brightness portion of the signal is amplified. The color burst is sent to the color-synchronization circuits to reconstruct the color subcarrier. The synchronization separator and automatic gain control sections are integrated with the signal-processing circuits. The color sidebands are separated from the signal and sent to a separate chrominance processing stage.



**Figure 1:** Block diagram of a typical IF stage

Problems in the video IF signal amplifier may cause, in all cases, a normal raster coupled with an overloaded or negative picture and buzzing in the sound output, a washed-out color or weak monochrome picture and weak sound, no picture but normal sound, or no picture or sound.

### Missing Sound

Sound may be missing depending on where the error occurs in the IF circuit. If the sound is removed before the error occurs, the sound will most likely be passed correctly. In a color receiver, the sound is pulled from the second or third IF amplifier. This may help in localizing which circuit or circuits are at fault. If there is no sound or picture, the problem will be an open signal path. The problem may be in the tuner as well as in the IF amplifier. The tuner should be checked first to see if a signal is being passed to the IF circuits. If there is a signal but no picture and sound, the problem lies in the IF circuits.

An IF circuit can be damaged if the AGC system is defective. Without proper AGC the IF stages can be driven to complete saturation.

Weak sound and picture, overload, or negative picture and buzzing indicate



different IF problems. These problems usually stem from an improper AGC applied to the final video of the IF amplifier stage. To check the AGC, a substitute bias clamping DC voltage for the AGC control voltage is used. The manufacturer's service manual will indicate the correct application points and correct voltages to use.

If the alignment of video IF stages changes, picture and sound can be affected. Improper alignment of these stages may cause intercarrier buzzing in sound output, an abnormal horizontal or vertical sync of the picture display, bars in the picture produced by sound, lack of color, some forms of ghosting. To check the alignment of the IF, adjust the fine-tuning. If correctly adjusted, the fine tuning should only cause minor changes in the overall picture.

Major changes in fine-tuning indicate that there is an alignment problem. If the picture weakens, overloads, smears or increases ghosting, the video IF amplifier response curve has been altered. A misaligned IF trap or IF strip can create washed out colors and poor color fit.

Changing the shape of the IF response curve may cause other problems to occur. Picture smearing, color loss, horizontal and vertical sync, and ringing may occur with a loss of low-frequency response.

## Ringling

Ringling occurs when excessive gain is created by the IF amplifier. This ringling, or ghosting, will show up on an oscilloscope as several peaks at the regenerative frequencies. The fine-tuning control will change the number, position and intensity of the ghosting patterns.

To check for ringling, simply attach a pattern generator to produce a crosshatch display on the screen. The vertical lines are produced by the high-video frequencies and the horizontal lines are produced by the low-video frequencies.

Adjust the fine-tuning so the horizontal and vertical lines are equal in intensity. Any ghosting or ringling will be seen to the right of the vertical lines. Adjusting the fine-tuning will cause the ghosting to change position and number. For this test to work, the picture carrier must be positioned at the proper 50 percent gain point on the IF response curve.

Ringling or ghosting can be caused by video IF misalignment, defective tuned circuit, defective amplifier transistors, open IC damping resistors, improper placement of components, removed or disconnected shielding, open capacitors, or open or shorted AGC filter capacitors.

**6/TTV**

Tube TV

---

6/TTV - TR

Troubleshooting and Repair

---

6/TTV - TR - IFA

IF Amplifier

---

---

## 6/TTV - TR

### Troubleshooting and Repair

---

## 6/TTV - TR - PS

### Power Supplies

---

### Picture and Sound Problems

The root of many problems stems from a power supply that is defective or improperly adjusted. A drop or loss of supply voltage can cause multiple symptoms that affect the picture and sound in a receiver. Possible indications may be a screen with no raster, weak sound or no sound, repeatedly blown fuses, incorrect raster size, brightness, linearity problems and even humming in the sound output. Components that have changed in value can cause these problems. Circuits that do not cause blown fuses or opened circuit breakers are usually caused by open components. Shorted or leaking components cause overheating or excessive current flow that should blow fuses and circuit breakers. Standard power supply checking is the best method for locating problems.

#### Weak Sound

Weak sound or a complete loss of sound may indicate a defect in the filter network. There may be defective capacitors or resistors or changes in the specifications for these components.

#### Humming

Power sections with defective rectifier diodes, open or leaky input filter capacitors, defective regulators, or defective zener diodes may cause the picture raster to shrink, to be darker, or have poor linearity. There will usually be a humming associated with these problems. These occur with a reduction in supply voltage.

#### Crosstalk

DC ripple can cause several receiver problems, like crosstalk, if the power supply is not filtered properly. Crosstalk happens from stray electromagnetic or electrostatic coupling of energy from one circuit to another.



6/TTV - TR	Troubleshooting and Repair
6/TTV - TR - PS	Power Supply

# 6/TTV

## Tube TV

6/TTV - TR	Troubleshooting and Repair
6/TTV - TR - T	Tuner

## 6/TTV - TR

### Troubleshooting and Repair

## 6/TTV - TR - T

### Tuner

**Channel Allocation** The tuner selects and processes a channel frequency. Television tuners can process channels 2 through 13 on VHF, and channels 14 through 69 on UHF. This corresponds to frequencies between 54 MHz to 88 MHz with a gap between 72 and 76 MHz for low-band VHF channels 2 to 6, 174 MHz to 216 MHz for the high-band VHF channels 7 to 13, and 470 MHz to 806 MHz for the UHF frequencies. Originally the spectrum included channels to 83. Channels 70 to 83 have been reallocated to cellular phone and high-band FM CB radio. Some stations still operate within this spectrum, but will slowly be phased out of operation or relocated before the year 2000.

Table 1 shows channel allocation frequencies needed for tuner repair.

### RF Section

The tuner is also considered to be the RF section, or front end, of a video receiver. The tuner contains an RF amplifier, an oscillator and a mixer stage.

The RF amplifier boosts the signals received by the antenna. The level amplified is dependent on how weakly the signal is received. A weak signal needs more amplification than a strong one and is determined by relative signal strength. The formula for this is:

$$rss = \frac{1}{(\text{relative distance})^2}$$

### AGC Circuit

This amplification is controlled by an automatic gain control (AGC) circuit which outputs a constant level and decreases that level when a stronger signal is received. The AGC processes both video and sound signals.

A failing or misaligned AGC section can cause the RF tuner, IF stages, video detector and video amplifier to appear defective. The AGC is composed of a pulse generator and coupling system, an input system from which AGC DC voltages are created, and an output network that applies control and delay voltages to RF and IF amplifiers.

6/TTV - TR	Troubleshooting and Repair
6/TTV - TR - T	Tuner

**Table 1**  
**Channel**  
**Allocation**  
**Frequencies**

Channel	Frequency	Channel	Frequency	Channel	Frequency
2	54-60	25	536-542	48	674-680
3	60-66	26	542-548	49	680-686
4	66-72	27	548-554	50	686-692
5	76-82	28	554-560	51	692-698
6	82-88	29	560-566	52	698-704
7	174-180	30	566-572	53	704-710
8	180-186	31	572-578	54	710-716
9	186-192	32	578-584	55	716-722
10	192-198	33	584-590	56	722-728
11	198-204	34	590-596	57	728-734
12	204-210	35	596-602	58	734-740
13	210-216	36	602-608	59	740-746
14	470-476	37	608-614	60	746-752
15	476-482	38	614-620	61	752-758
16	482-488	39	620-626	62	758-764
17	488-494	40	626-632	63	764-770
18	494-500	41	632-638	64	770-776
19	500-506	42	638-644	65	776-782
20	506-512	43	644-650	66	782-788
21	512-518	44	650-656	67	788-794
22	518-524	45	656-662	68	794-800
23	524-530	46	662-668	69	800-806
24	530-536	47	668-674		

If the problem lies in the AGC circuit, use bias clamping voltage to decide if the AGC outputs are causing problems in the video IF amplifiers. If the receiver is otherwise operating properly, the AGC circuit could be bad.

AGC defects will cause no picture and/or sound, a weak picture and/or sound, and overloading or a negative picture with possible buzzing.

To determine if the problem is in the AGC circuit, you must apply bias clamping voltage to the AGC common or bus connection, use an oscilloscope and demodulator probe to check the output of the last video IF stages, and scope the output of the last video IF stage. The manufacturer's specifications will aid in this approach.

AGC circuits use synchronizing pulse amplitude rather than overall video signal amplitude to create a DC control voltage. An overall video signal amplitude would cause the picture brightness to vary in relation to the signal being

amplified. The output DC control voltage is sent to the RF and IF amplifiers. For the amplifier and other signal processing circuits to work properly, they need to operate on specific frequencies known as intermediate frequencies (IF). Sound IF is 41.25 MHz and video IF frequency is 45.75 MHz.

IF frequencies are created by an oscillator that heterodynes the incoming RF signals. Heterodyning is a process of combining two frequencies which alternately reinforce and cancel the other's waveform.

**IF Frequency**

A video receiver uses the difference between the tuner oscillator and the TV channel frequency as its IF frequency. Any other frequencies created by

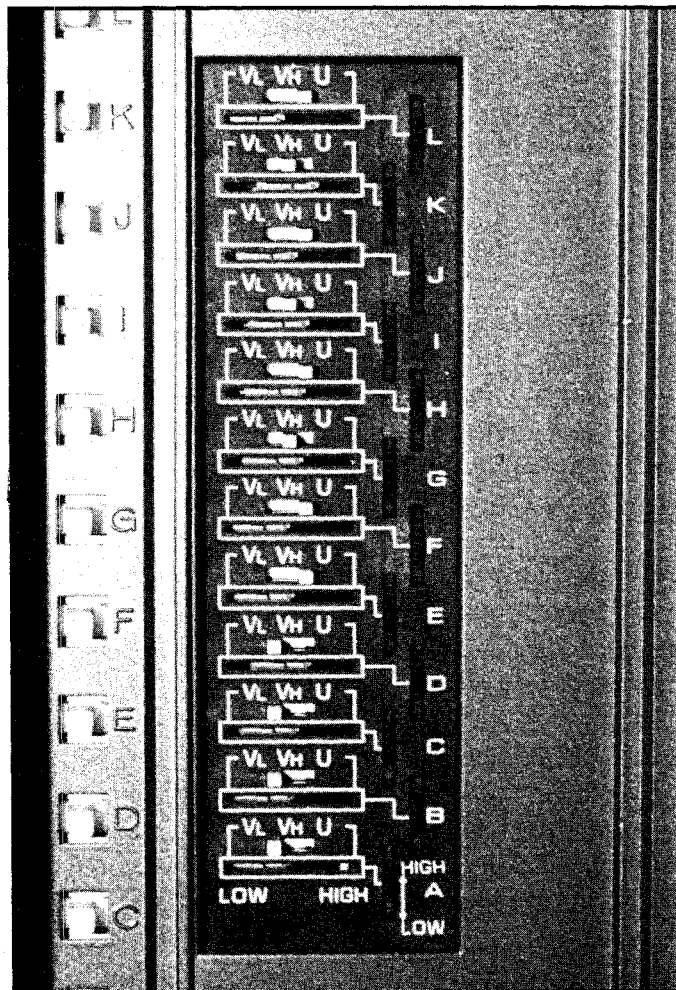


Figure 1: Wafer tuner

6/TTV - TR	Troubleshooting and Repair
6/TTV - TR - T	Tuner

heterodyning are rejected by the tuned circuits at the mixer output and IF amplifier.

The oscillator frequency to generate the required 45.75 MHz video IF and the 41.25 MHz audio IF must be changed in accordance with the channel selection. The frequencies must be 45.75 MHz above the video carrier. For example, if the tuner is set to channel 12, the picture carrier is at 205.25 MHz, so the oscillator must be at 251.0 MHz. The audio IF must be 41.25 MHz above the audio carrier which, for channel 12, is 209.75 MHz, so the sound IF oscillator must be at 251 MHz.

Modern receivers use automatic fine-tuning (AFT) circuitry to maintain an accurate signal and adjust the oscillator accordingly.

Tuners in televisions can be either mechanical, electrical mechanical, or electronic. Mechanical tuners are found in cheaper or older television receivers. Mechanical tuners are either wafer-type or turret-type.

### Wafer Tuner

A mechanical wafer tuner uses thin, flat, wafer-shaped nonconductive bases on which coils and switches are mounted.

A sliding switch contacts the inner metal plate connected to the coils. As the tuner shaft is rotated, it increases or decreases, the number of coils that are shorted. As the inductance L value in an LC circuit increases, the circuit's resonant frequency allows the tuning of VHF low-band channels 2 through 6. VHF high-band channels 7 through 13 are tuned by portions of a stamped metal inductance ring which are shorted in a similar fashion.

### Turret Tuners

A mechanical turret tuner, as shown in Figure 2, has removable grouped sets of precisely tuned coils arranged in a rotating circular fashion. When changing channels, turret tuners have a better ability to tune the same frequency accurately and repeatedly than wafer-type tuners.

### Mechanical Electronic Tuners

In a mechanically switched electronic tuner, a group of about 16 to 20 variable resistors are connected between a constant voltage source and ground. The voltage drops generated by the resistors are applied to the tuner varactor diodes. Each resistor is adjusted to produce a specific voltage and is selected by either a push-button system, or rotary-switch system.

Varactor diodes produce varying amounts of capacitance in tuner circuits. As there is an increase in reverse bias, a varactor produces less capacitance. This increases the resonant frequency of an LC type.

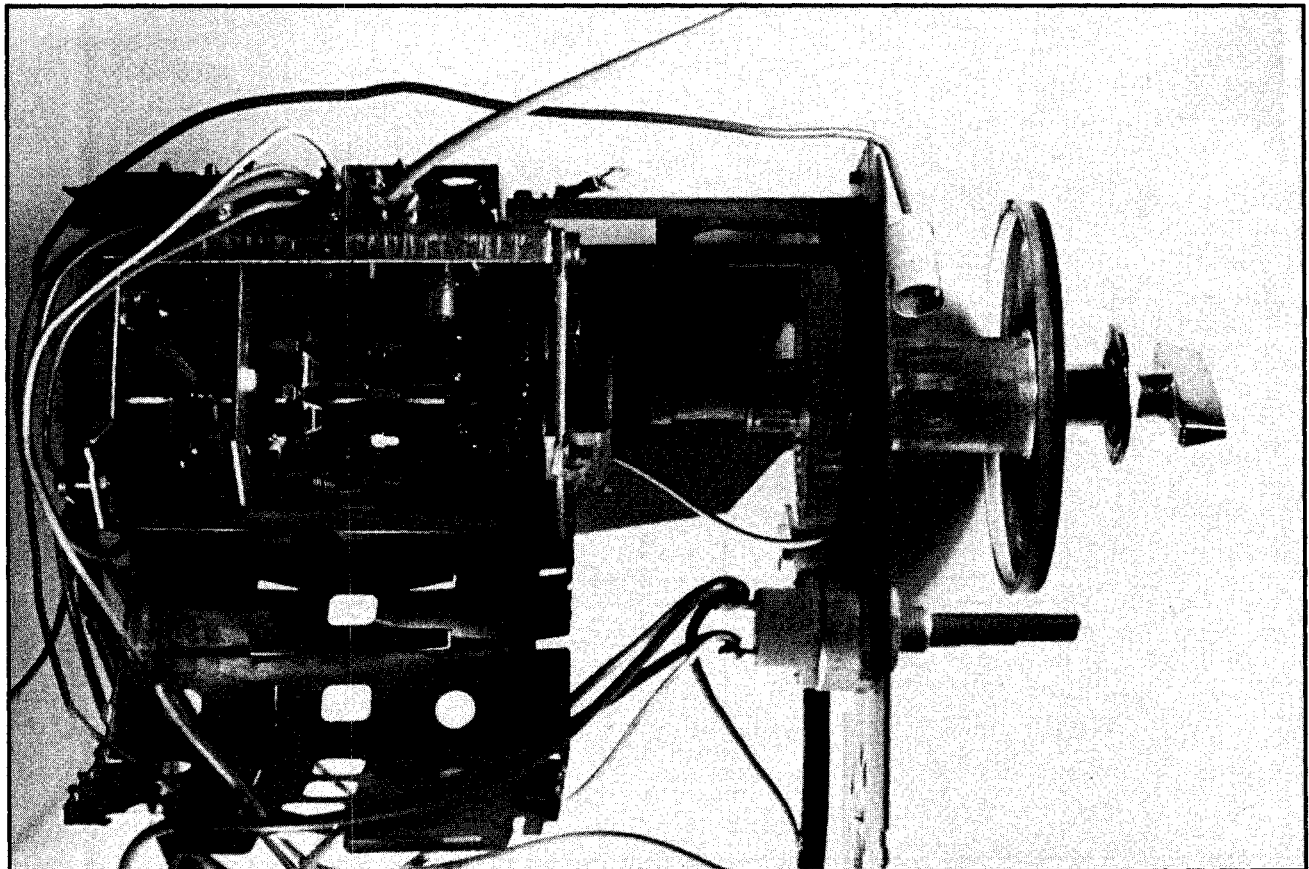


A switch selects the amount of reverse bias voltage which then determines the channel selected for viewing. Each switch position is connected to a different variable resistor for discrete channel selecting. A varactor diode and capacitor create the resonant circuit. Another capacitor is used to isolate the varactor diode from DC potential and provide an AC ground.

**Electronic Tuners** Many TVs today employ IC tuner sections. A single IC can perform all or part of the tuner functions. The use of an IC for tuning is more reliable and cheaper. Figure 3 shows a block diagram of an IC-based tuner circuit.

Different types of electronic tuners can be created that will electronically create varactor reverse bias voltages. Some types employ digital switching, memory storage, and phase-locked loop tuning.

A digital switching tuner offers a numeric keypad for input of the desired



**Figure 2:** Mechanical turret tuner

channel. The signal from the keypad is applied to a digital logic processing unit. A digital logic processing unit uses binary signals and mathematical logic to create the outputs applied to tuning circuits.

A memory storage device has digital equivalents of varactor bias voltages stored within. When a channel number is entered, the stored information for that channel is read and sent to the tuning circuits.

Phase-locked loop (PLL) tuning uses an electronic feedback system to sustain an extremely accurate varactor bias voltage. To do this, a PLL circuit compares phases of the output varactor tuning frequency and a digitally divided reference

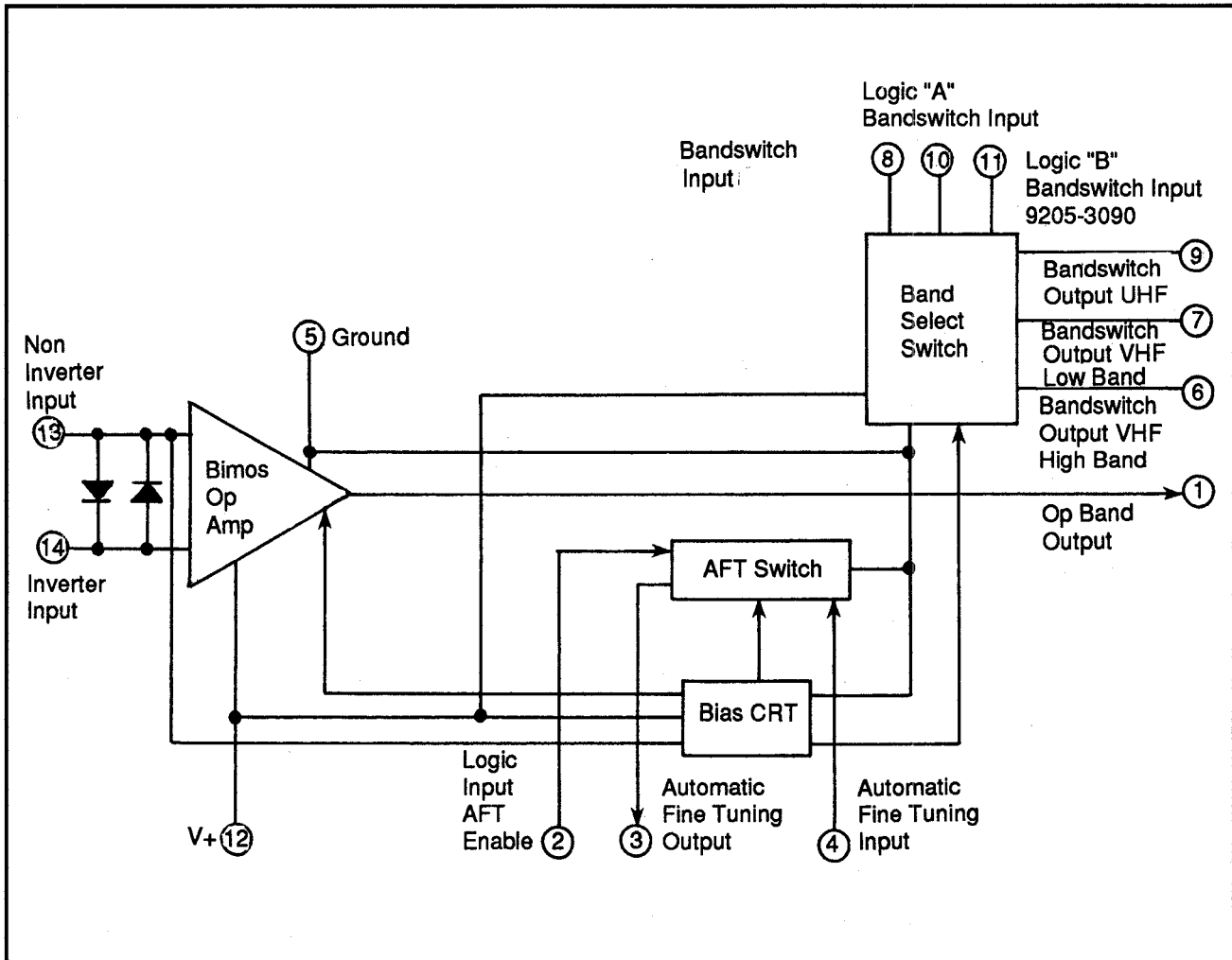
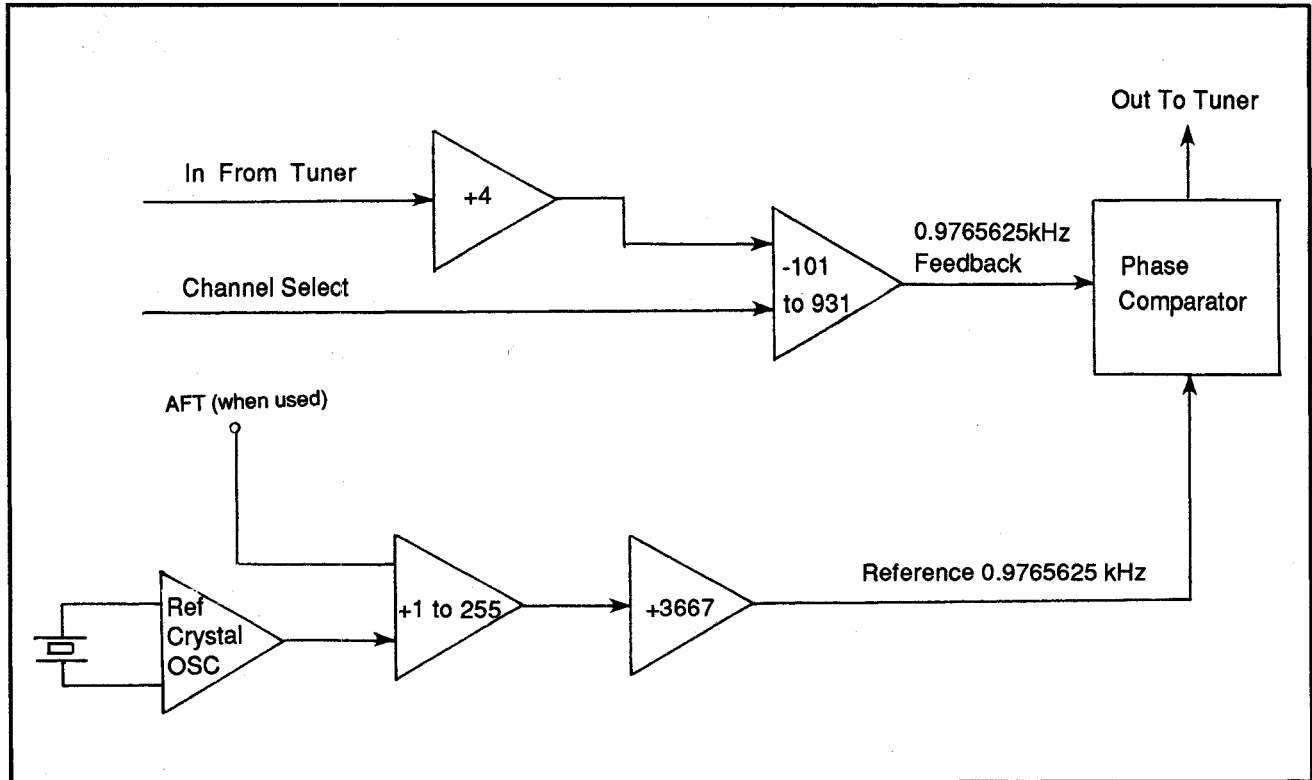


Figure 3: IC tuner block diagram



**Figure 4:** PLL tuning circuit

signal frequency. If there is a difference, the PLL system sends error signals back to adjust the output signal to the desired level. A PLL tuning section is shown in Figure 4.

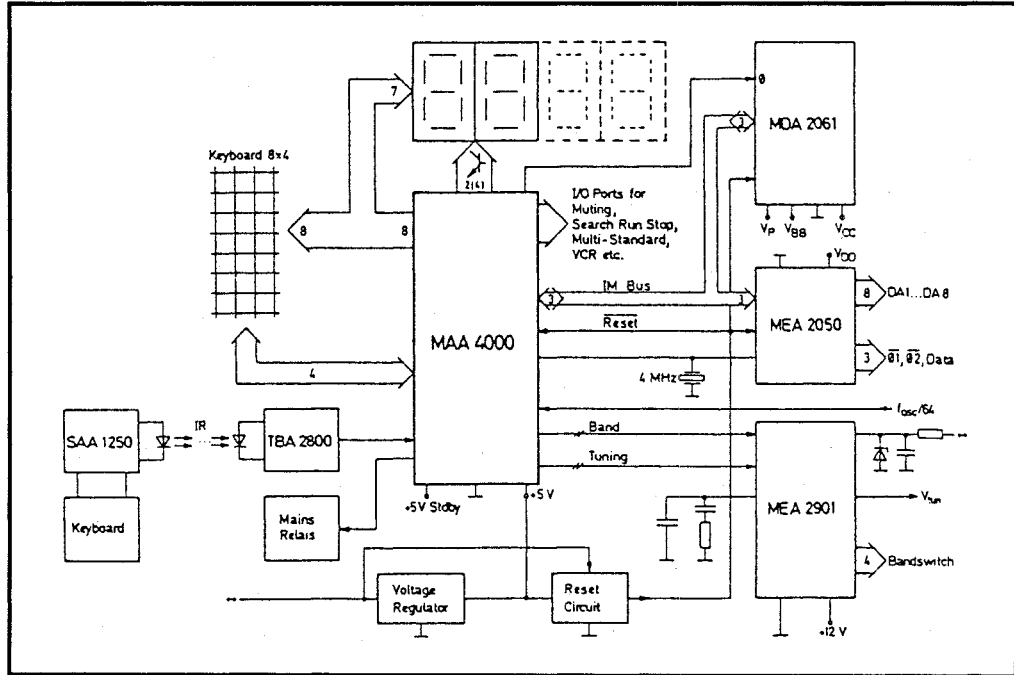
## Tuner Diagnosis and Repair

Any signal to be processed by a video receiver must pass through the tuner. The tuner can be the cause of many problems in picture display and audio performance. Tuner malfunctions include:

- Loss of all channels, or low or high channels
- Intermittent reception of one or more channels
- Weak or poorly defined picture
- Loss of color or poor color
- RF amplifier or mixer stage oscillation

### All Channels with Problems

If there is a visible raster and the power supply is functioning properly, but there is a lack of picture, color, and sound, it indicates that information is not being



**Figure 5:** IC tuner circuit

processed between the antenna input and the video detector output. The video amplifier stages can be eliminated from testing because sound and color outputs will be generated even when the video amplifiers malfunction.

The quickest method to determine if the problem lies in the tuner is to use a tuner snubber. This is a portable, battery-powered tuner that is used to temporarily replace the tuner in the set. If using an electronic tuner, swapping the tuner circuit is the easiest method for determining tuner trouble. If the trouble goes away by either method of substitution, the problem is in the tuner.

Mechanical tuners are subject to wear. Damaged or broken mechanical contacts can cause a complete loss of picture and sound. A mechanical tuner should be carefully inspected for damage to the contacts. In this case it is best to replace the entire tuner. Also, lead lengths in the VHF circuitry are nearly as critical as exact component replacement. If a VHF mechanical tuner is replaced, all connecting leads must be of the same length.

Electrical problems in tuner processing stages can cause a complete loss of picture and sound due to the RF amplifier, mixer, local oscillator or the AFT processing stage.

# 6/TTV

## Tube TV

6/TTV - TR	Troubleshooting and Repair
6/TTV - TR - T	Tuner

If the RF amplifier is bad, no signal will be passed to the mixer. A defective mixer will prevent the RF signal from being heterodyned, even when the RF amplifier and oscillator are working properly. An oscillator may fail either by a defective oscillator or because the AFT processing stage has failed.

### Low or High Channels with Problems

If a tuner is experiencing problems on either low or high channels only, the problem could be: a defective local oscillator transistor or IC, the local oscillator frequency is incorrect, defective mechanical tuner contacts, neutralizing capacitor misadjustment, defective coils or capacitors, or open or shorted capacitors in the antenna system. When a neutralizing capacitor is misadjusted, it could prevent some or many different channels from operating.

### Weak or Poorly Defined Picture

A weak picture with possible noise interference and possible sound problems could be caused by a weak input signal at the receiver input, or inadequate amplification. The causes may be weak or defective transistors or ICs, dirty mechanical tuner contacts, wrong local oscillator voltage injection, value changes of components causing misalignment, or excessive AGC voltage levels. Dirty contacts are usually taken care of by simply cleaning them with a tuner contact cleaner.

In some tuners a test point known as a looker point may be available to aid in troubleshooting. Attaching an oscilloscope to view the tuner frequency response curve is possible at such a test point. Using a high-gain scope with a demodulator probe allows one to trace signals after the mixer stage. Also the test point may be used to decide whether certain frequency levels are able to pass through the RF amplifier.

### Intermittent Reception

If one or a few channels are having trouble, the problem may be caused by mechanical tuner contacts. Dirty or damaged contacts will be the main problem. If any are damaged, the best fix is to replace the tuner.

If all channels are exhibiting the same symptoms, the problem lies in the DC operating conditions related to the tuner stages. The first step would be to check the local oscillator. If good, the next step is to check the RF amplifier and mixer stages. Proper waveforms and voltages are referenced within the manufacturer's schematics.

### RF Amplifier of Mixer Stage

Problems that occur when an RF amplifier or mixer stage begins to oscillate include motorboating, herringbone pattern interference in the picture display, erratic reception when the fine-tune control is adjusted, and complete loss of picture and sound. These circuits can be made to oscillate by a tuner misalignment, an open bypass capacitor, an open AGC isolating resistor, any faulty

**6/TTV**  
 Tube TV

6/TTV - TR	Troubleshooting and Repair
6/TTV - TR - T	Tuner

connections, or misadjusted or a defective RF amplifier neutralizing capacitor.

**Poor Color or  
Lack of Color**

Improperly adjusted fine-tuning will cause color to be lost or look poor. If this is so, the color control should be set to provide maximum color level. Then the fine-tuning should be adjusted to produce normal color reproduction. If the unit has an AFT circuit, turn it off to see if the color problem is repaired. You may also need to manually tune the channel. If the problem goes away, the AFT circuit is bad.

If problems like ghosting, or smearing occur due to the fine-tuning, use a sweep generator to check and align the tuner and the IF stages.

## 6/TTV - TR

### Troubleshooting and Repair

---

## 6/TTV - TR - VS

### Video Signals

---

#### The Composite Video Signal

Within a composite video signal for a color television are two parts: the luminance signal and the chrominance signal. The luminance signal creates the black-and-white image and the chrominance signal produces the color for that image.

#### Luminance Signal

The luminance, or Y signal, generates a complete black-and-white image on a receiver. In a color system the Y is used for creating the brightness and detail information. The luminance extends 1.25 MHz below the picture carrier frequency to about 4.3 MHz above it. The finer picture details are found in the upper sideband.

#### Chrominance Signal

The chrominance signal produces the color in the image. It is not visible without the luminance signal. This chrominance signal modulates the 3.58 MHz color subcarrier. Actually, the color subcarrier is assigned a frequency of 3.579545 MHz, but is often referred to as 3.58 MHz. Color information sidebands occupy a bandwidth that extends from about 2.08 MHz to 4.18 MHz.

#### Chromaticity

To understand what the human eye can and cannot see as far as color goes, one needs to look at a standard chromaticity diagram. Figure 1 shows this chart. The chart was created in 1931 by the *Commission Internationale de l'Éclairage* (CIE) in France. It depicts colors in terms of hue and saturation.

Saturation is measured from just below the white-dot area which is just below the CIE illuminant. Saturation radiates outward in all directions along the X and Y axes. The numbers in the chart are specified in nanometers of the various visible colors. The three primary colors of light, red, blue, and green are on the chart, with red at the right, blue the bottom left and green at top. Other intermediate hues are listed throughout the spectrum.

Color used for television does not generate the entire spectrum as shown here, but rather a subsection, illustrated by the triangular section overlaid in Figure 2.

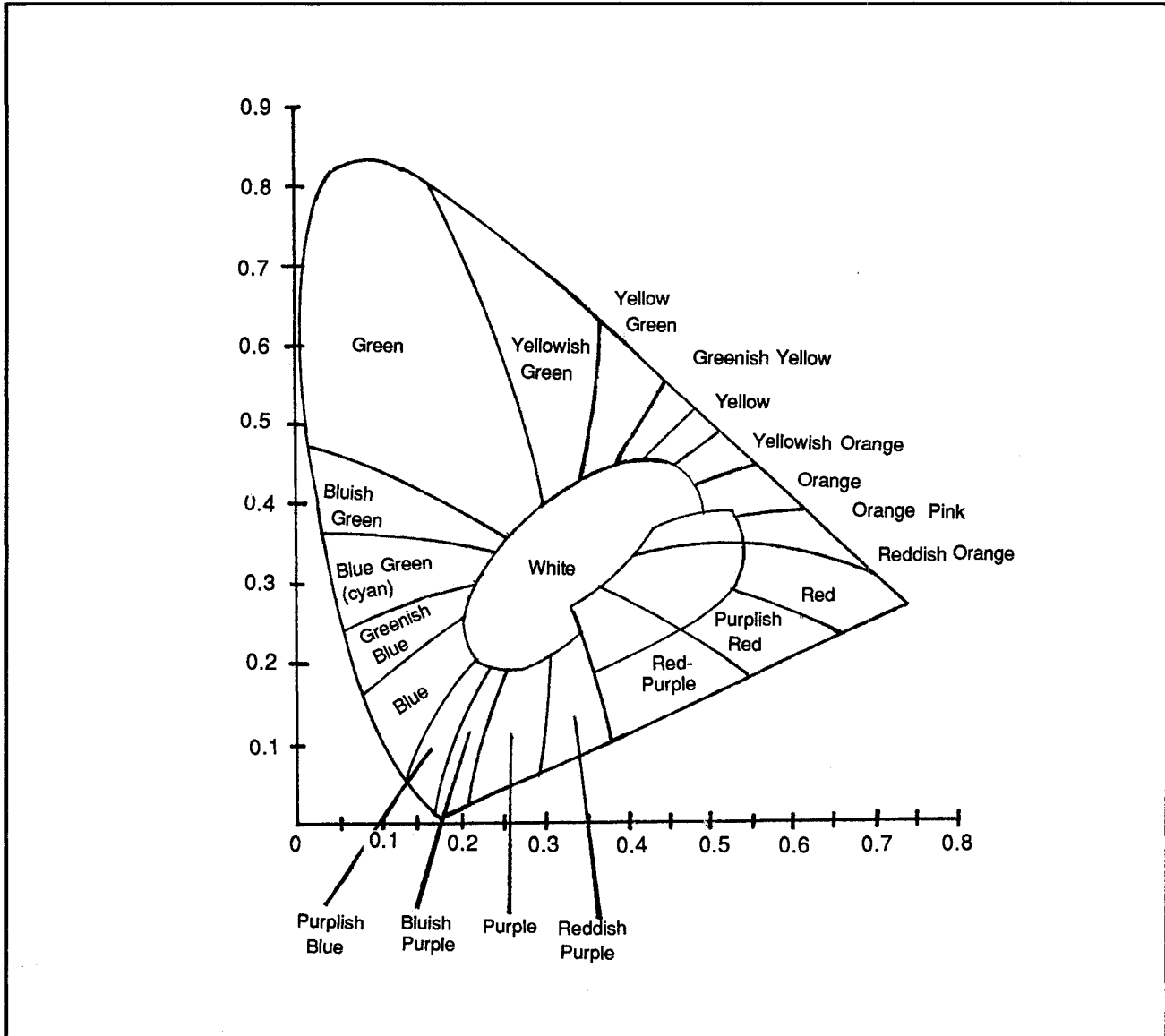
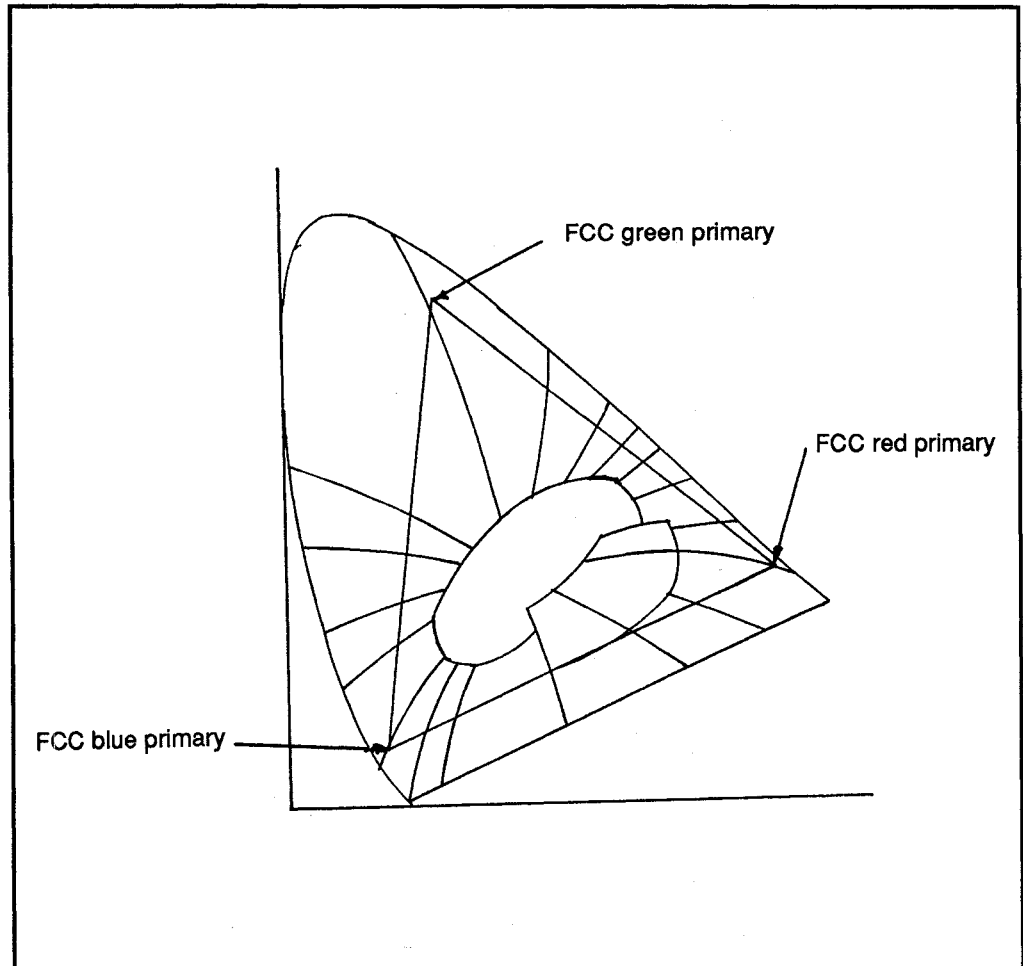


Figure 1: Chromaticity diagram

The Federal Communications Commission has specified the values of red at 0.67X and 0.33Y, blue at 0.14X and 0.08Y and green at 0.21X and 0.71Y.

A color TV can reproduce any color that occurs in nature, but certain hues like purple and green cannot be generated at full saturation. In nature, hues rarely occur at maximum saturation, so this limitation is not a major problem.





**Figure 2:** CIE chart with NTSC overlay

### Modulation

Within an analog transmitted signal is information that is modulated. The percentage of modulation can vary, and in general it is desirable to have a high percentage of modulation in a transmitted signal. Modulated signals are never modulated at 100 percent because it is possible that overmodulation will occur and distort the signal. Overmodulation causes momentary carrier cutoffs.

### Picture Phase

Video signals are transmitted in a negative picture phase to achieve the maximum transmitter efficiency. The brightest portion of a picture will have the least amplitude and the darker portions will have a higher amplitude. The blackest section which occurs at a region higher than 75 % means the electron beam of the tube is cut completely off by the bias voltage on the control grid. The brightest part of the picture occurs at 12.5 % relative amplitude.

By inverting the picture phase, the amount of distortion and interference is reduced. Some of this interference occurs from atmospheric disturbances and harmonics from other broadcast signals. These two interferences cause the amplitude of a broadcast signal to increase. So a picture in positive phase has signals that create pictures brighter than desired. By inverting the signal, any increase in amplitude creates a darker picture. Darker picture areas are less noticeable than lighter areas.

When the signal is received by a receiver, the signal is reinverted to a positive phase. In a positive phase system, the brighter information is more positive than the darker images, so the negative bias of the control grid is reduced to allow electron flow and the electron beam excites the picture tube phosphors.

### Black and White

To create a black-and-white, or monochromatic picture with proper contrast, the red, green and blue (RGB) signals must be combined in certain percentages. To create an acceptable monochrome signal, the signal consists of 30% red, 59% green, and 11% blue. The varying degrees of the Y signal produce varying degrees of light and dark areas which make the complete monochrome picture.

### Color Picture Signal

Color is transmitted as phase differences within a color signal. The more color required, the larger the difference between phases. Increasing the phase differences increases the bandwidth of the color signal, which in turn, increases the size of the composite signal.

The human eye is capable of distinguishing brightness differences but not color differences in very small areas. Therefore, in larger areas there are more combinations of RGB producing color than in smaller areas. Smaller areas may only need two of the three primary colors and edges between color areas will only require brightness differences.

By transmitting only the color information needed for the large and medium areas, the bandwidth for the signal can be cut down. This reduction in information assures that the color signal will fit in the space allocated for color.

The color subcarrier, a subpart of the color signal, must be modulated so that the complete color information is transmitted. Transmitting information for each of the three primaries would extend beyond the bandwidth of 6 MHz, so two methods of modulation are employed.

Two 3.58 MHz color subcarriers are generated, 90° out of phase with each other. The two AM color subcarriers and their resultant sidebands are then able to be

combined. The resultant, or phasors, of the signals are proportional to the strength of each of the signals. Different phasors (resultants) will be created by the combinations of signals at different strengths.

The hues of color are determined by the phase angle of the resultant. Color saturation is determined by the length or amplitude of the resultant. Any phase shift will create incorrect colors.

The color signal is located at 3.58 MHz with the color information sidebands below and above. The amount of color information to produce a satisfactory color image can be found in sideband frequencies of 0 to 1.5 MHz. Resultants of different angles are needed to create single colors.

### Chrominance Section

A block diagram of a chrominance section is shown in Figure 3. The chrominance section separates the I and Q signals and demodulates them to produce the original RGB information. These signals are then sent to a matrixing network.

In the matrixing network, the RGB signal is proportioned to create a proper color picture. Output from the matrixing circuit is fed to the red, green and blue electron guns in the color picture tube. The chrominance section is switched off when black-and-white video signals are received due to the lack of the color burst signal.

The operation of the chrominance section is controlled by the color killer stage. The color killer stage detects the color-burst signal and turns the color killer stage off, allowing color information to pass freely.

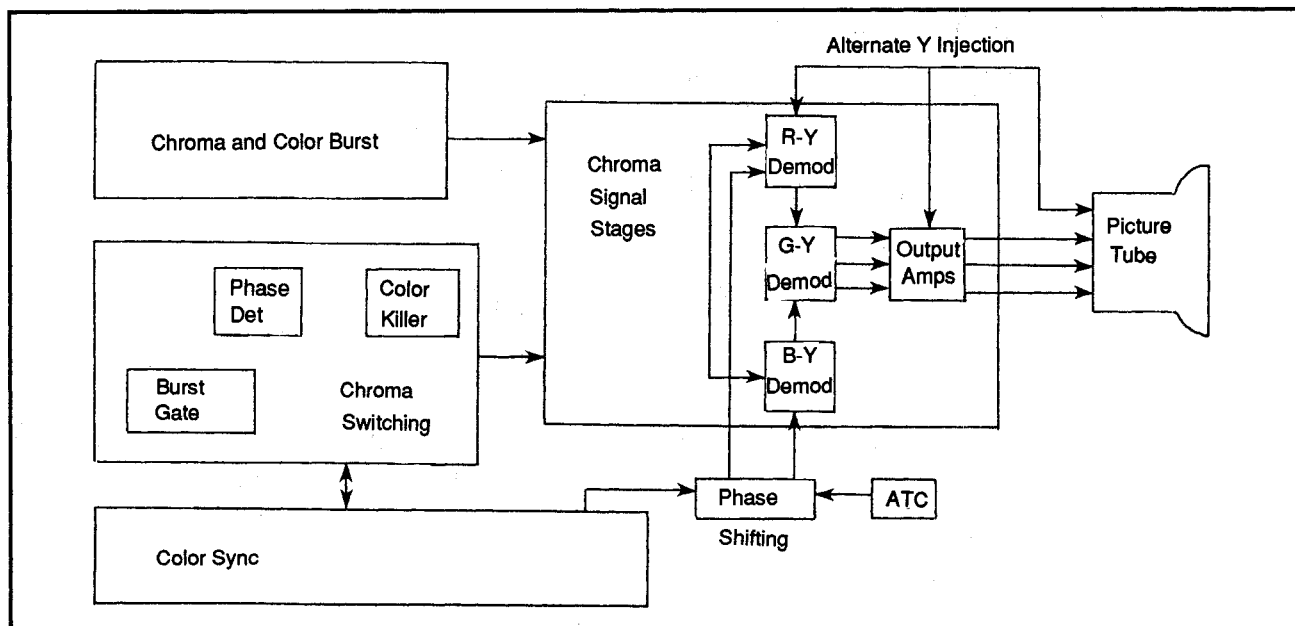
To control the color killer stage and the color subcarrier stage, a phase detector is used. A phase-detector circuit creates a DC control voltage in response to signals of a given phase difference.

The burst gate is an amplifier that increases the level of the color burst. To eliminate problems with black-and-white pictures, the burst gate is limited to 0.5 MHz and is only on during the color burst signal at the time of the horizontal retrace.

### Color Synchronization Sections

The color sync section creates a stable 3.58 MHz signal that is used as a reference to lock the phase. This signal is mixed with the color signal sidebands in the chrominance section to recreate a complete color signal.

The synchronization pulse separator removes the sync pulses from the detected



**Figure 3:** Block diagram of a chrominance section

signal and amplifies them. These pulses are then sent to the vertical and horizontal deflection circuits through integrating and differentiating networks. The integration network uses low-pass filters to create signal voltages of longer duration. Differentiation is the use of high-pass filters to create signal voltage of shorter duration.

### I and Q Signals

Along with the color subcarrier are two signals designed to reduce the phase shifts and the bandwidths required for transmission of color signals. These are the I (in phase) and Q (quadrature) signals.

The I and Q signals are positioned at a 90° phase difference. Resultants of the I and Q signals aid in reproduction of a full range of colors needed for large areas, with as much as 0.5 MHz resultants being used. In medium areas the I signal is only needed to produce colors that appeal to the viewer. A +I signal can be found between the yellow and red hues and the -I signal between the blue and cyan hues. The I and Q signals modulate the 3.58 MHz subcarrier to transmit color information.

**6/TTV**  
Tube TV

---

6/TTV - VCS

Various Case Studies

---

6/TTV - VCS - Mag T985/T986

Magnavox

---

## **6/TTV - VCS**

### **Various Case Studies**

---

## **6/TTV - VCS - Mag T985/T986**

### **Magnavox Chassis**

### **T985-05/-06/-07/-08, T986-06**

---

The following is a case study for the above listed Magnavox chassis televisions. The set consists of various integrated circuits and discrete electronic components. The tuners are mechanical tuners. From a repair standpoint, this is a low-end set, but with a solid understanding of such sets, the more complicated, fully integrated sets can be better appreciated.

### **Disassembly Instructions**

The disassembly described here will be needed for servicing the TV. In some cases, only the chassis cabinet will need to be removed. In extreme cases (picture tube replacement) the entire disassembly will need to be done. Basic disassembly starts with the cabinet removal.

Disconnect antenna leads and remove the seven screws holding the cabinet back to the set. This is best accomplished with the set picture tube down.

To access the picture tube and various elements around the tube you will need to disconnect the CRT socket, HV anode lead, deflection yoke plug, degaussing coil plug, speaker leads, and the various ground wires.

#### **Warning!**

*Be sure the picture tube has been discharged before disconnecting.*

Remove the four screws holding the chassis. Remove the chassis from the swing pin and lift the chassis from the cabinet. The CRT can be removed at this point.

To remove the CRT, remove the four screws holding the degaussing shield and lift the shield from the cabinet. Remove the two screws holding the CRT retaining wires and remove the wires. Lift the CRT from the cabinet.

# 6/TTV

Tube TV

6/TTV - VCS

Various Case Studies

6/TTV - VCS - Mag T985/T986

Magnavox

## Tip

Do NOT remove the CRT by lifting it by the neck. The tube is likely to rupture. The resulting implosion can cause severe injury. When the CRT has been removed, store it face down on a soft, protective surface.

Remove all the knobs from the front of the cabinet. Remove the four screws holding the tuner and control assembly and lift the assembly from the cabinet.

## Troubleshooting

The T985/986 chassis is always at a level above ground potential, regardless of the line polarity. An isolation transformer should always be used when operating the set with the back cover removed.

Parts used for replacement should be matched exactly or as closely as possible. Many of the parts recommended in the service literature are designed with special safety-related characteristics that may not be evident from visual inspection. Using components rated at a higher voltage, wattage, etc. will not always serve well as replacement parts. Use of parts not recommended by the service literature may cause shock, fire or other hazards.

## Troubleshooting Checklist

When troubleshooting the Magnavox line of TVs (in this particular model) the following checklist may be of use.

PICTURE OR SOUND	AREA TO CHECK
No picture, sound and raster	Circuit breaker or fuse Load sensor or line sensor 24 V regulator Bias regulator - D1, D2, or Z1 Power supply module - BR1, SR1, Z1 120 V regulator module
No picture and sound, but has raster	Tuner 1st, 2nd, or 3rd IF AGC gate Noise gate AGC-sync modules
No Picture and raster, but has sound	Delay line driver Video driver Vertical blanker Beam limiter CRT Video delay module
No picture and sound, but has snow	Tuner AGC gate Noise gate IF/AGC-sync modules

Section 6 • Television



6/TTV - VCS

Various Case Studies

6/TTV - VCS - Mag T985/T986

Magnavox

**Troubleshooting Checklist (cont'd)**

PICTURE OR SOUND	AREA TO CHECK
No sound, but has picture	Video output - D2 IF module Delay line driver Video driver Video delay module
Overload Picture	AGC gate Noise gate - D1, D2, D3, D4, D6, D7 AGC-sync module - D2 IF module
Low or excess brightness	Delay line drive Video delay module Beam limiter Video driver Vertical blanker

SWEEP PROBLEMS	AREA TO CHECK
No raster, but has sound	HV tripler CRT
No raster and sound	Horizontal oscillator, driver or output - D101 Horizontal oscillator/driver module
No vertical deflection	Vertical oscillator, switch, diff. amps, driver Vertical output - D1, D2, D3, D4 Vertical oscillator/driver module
Poor vertical line or foldover	Differential amps, driver Diff. Outputs - D1, D2, D3, D4 Vertical oscillator/driver module
Poor horizontal line or foldover	Horizontal driver, output Horizontal oscillator/driver module
Narrow picture	Horizontal driver, output - D101 Horizontal oscillator/driver module
Vertical off frequency	Vertical oscillator/switch Vertical oscillator/driver module
Horizontal off frequency	Horizontal oscillator Horizontal oscillator/driver module

SYNC PROBLEMS	AREA TO CHECK
No vertical sync	Vertical oscillator Vertical oscillator/driver module

**Troubleshooting  
 Checklist (cont'd)**

<b>SYNC PROBLEMS</b>	<b>AREA TO CHECK</b>
No horizontal sync	Horizontal oscillator Horizontal oscillator/driver module
Neither horizontal or vertical sync	Sync separator Noise gate - D5 AGC sync module

<b>RASTER PROBLEMS</b>	<b>AREA TO CHECK</b>
Yellow (No blue)	Chroma demodulator Blue video output CRT Chroma demodulator/RGB modules
Cyan (No red)	Chroma demodulator Red video output CRT Chroma demodulator/RGB modules
Magenta (No green)	Chroma demodulator Red video output CRT Chroma demodulator/RGB modules
No color	Chroma amp/oscillator Gate amp Chroma demodulator 3.58 MHz amp Chroma processor Chroma demodulator modules
Weak color	Chroma amp/oscillator Gate amp Chroma demodulator Chroma processor Chroma demodulator modules
No color sync	Chroma amp/oscillator Gate amp Chroma demodulator 3.58 MHz amp Chroma processor Chroma demodulator modules

<b>RASTER PROBLEMS</b>	<b>AREA TO CHECK</b>
No green	Chroma amp/oscillator Green video output Chroma demodulator/RGB modules



# 6/TTV

## Tube TV

6/TTV - VCS

Various Case Studies

6/TTV - VCS - Mag T985/T986

Magnavox

### Troubleshooting Checklist (cont'd)

RASTER PROBLEMS	AREA TO CHECK
No Blue	Chroma amp/oscillator Green video output Chroma demodulator/RGB modules
No red	Chroma amp/oscillator Green video output Chroma demodulator/RGB modules
Incorrect hue (tint)	Chroma amp/oscillator Chroma demodulator 3.58 MHz amp Chroma processor/chroma demodulator/ RGB modules

### TV Alignment

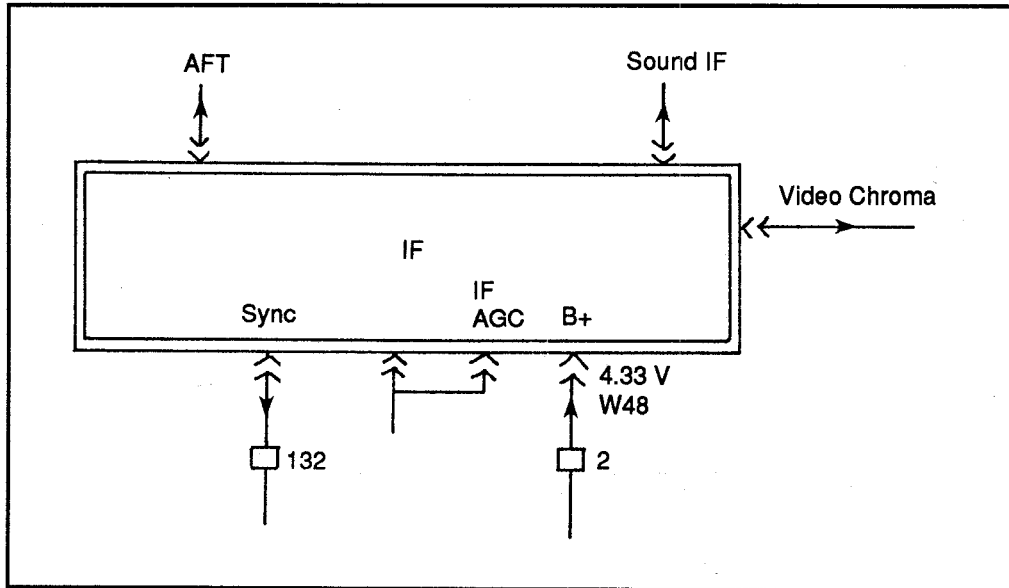
Turn the set on and let it warm up for at least 20 minutes. The test equipment should be allowed to do the same. Set the channel selector to the highest unused channel. Use an isolation transformer, or at the very least be sure to observe polarity. The line voltage should be maintained at 120 VAC (nominal). Ground test the equipment against the TV chassis ground unless otherwise instructed.

Set the scope sweep to external and connect the scope vertical input to the scope vertical output on the sweep/marker generator. Connect the scope external horizontal input to the scope horizontal output on the sweep/marker generator. When using the sweep/marker generator, use only enough generator output to provide a usable indication.

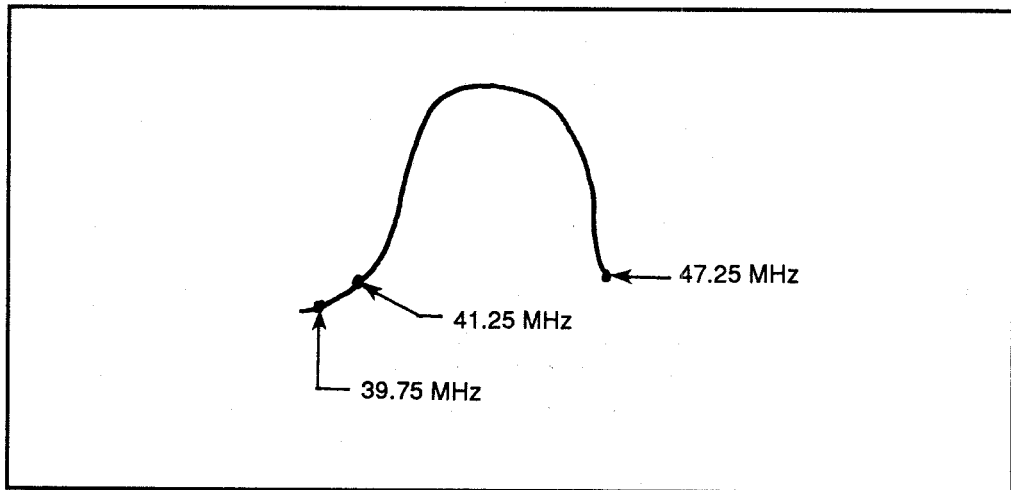
Set the service switch to the service position and the AFT switch to the off position. Connect a +0.5 V bias to connection W48. W48 is located on the IF module and is pin number 9. Figure 1 shows a cross section of this circuit. The normal range of the IF AGC connection (W48) is between -.98 V and 4.33 V. It should not vary outside this range. This connection will allow you to do a video IF alignment, 4.5 MHz Trap Alignment, Sound IF alignment, and the AFT alignment.

**Video IF Alignment** For the video IF alignment, connect the direct probe from the sweep/marker generator to TP 2. The test point on the VHF tuner should be connected to the sweep generator output and set to 44 MHz, or a 10 MHz sweep. TP 2 can be found as lead 59 coming from pin 2 of the chroma processor.

Refer to Figure 2 to see how the waveform will appear.



**Figure 1:** Location of W48 in cross section view of IF module circuit

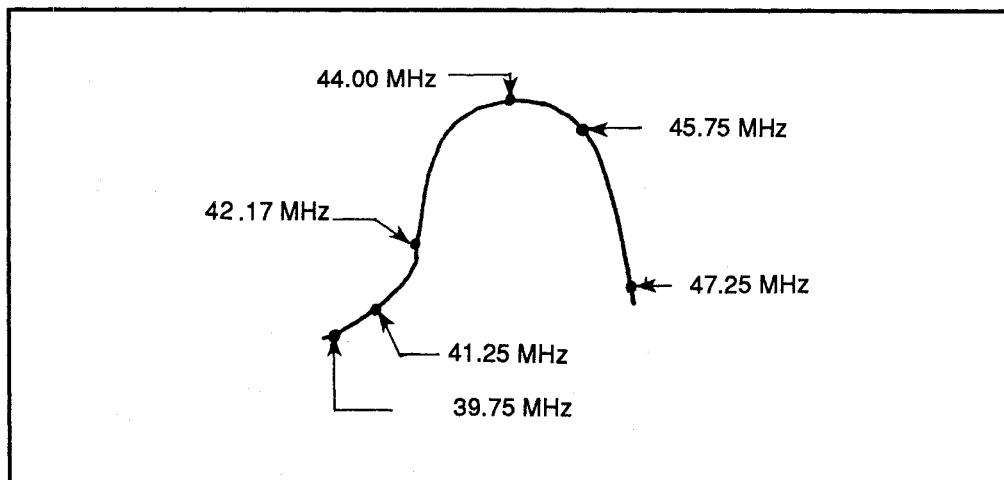


**Figure 2:** Waveform adjustments for 39.75, 41.25 and 47.25 MHz

Adjust L15 (IF module board) for a minimum response. The marker generator frequency will be 39.75 MHz.

Adjust L4 and L8 for minimum settings. The marker generator frequency will be 41.25 MHz.

Adjust L2 for a minimum setting. The marker frequency will be 47.25 MHz.



**Figure 3:** Waveform for adjustments from 39.75 MHz to 47.25 MHz

The next group of adjustments will fine-tune the various adjustments above. Refer to Figure 3 for the waveform.

Adjust L3, L5, L6, L7, L9 and the VHF IF output coil for the maximum gain possible. Also adjust for the best symmetry of response possible.

Adjusting L6 and L7 will affect the 44.00 MHz marker generator frequency. L5 will affect the 45.75 MHz response.

L3 and the VHF IF output coil affect the overall response.

#### 4.5 MHz Trap Alignment

The TV will need to be tuned to a strong TV signal or connected to a pattern generator with RF output. The contrast should be set at the maximum. Adjust the fine tuning until a beat pattern is visible on the screen. Adjust T1 of the IF module for a minimum beat interference.

#### Sound IF Alignment

The TV must be tuned to a strong TV signal. Adjust L1 for the maximum sound possible. Reduce the signal strength at the antenna terminals until distortion appears.

L2 should be adjusted after distortion appears. This is to align for an undistorted output. Continue to reduce the signal while doing this adjustment. Figure 4 shows the circuit for the sound module.

#### Automatic Fine Tuning Adjustment

Connect the direct probe from the sweep/marker generator to W2. W2 can be found on the AFT module as wire 53 (gray) connected to pin 2 of the AFT

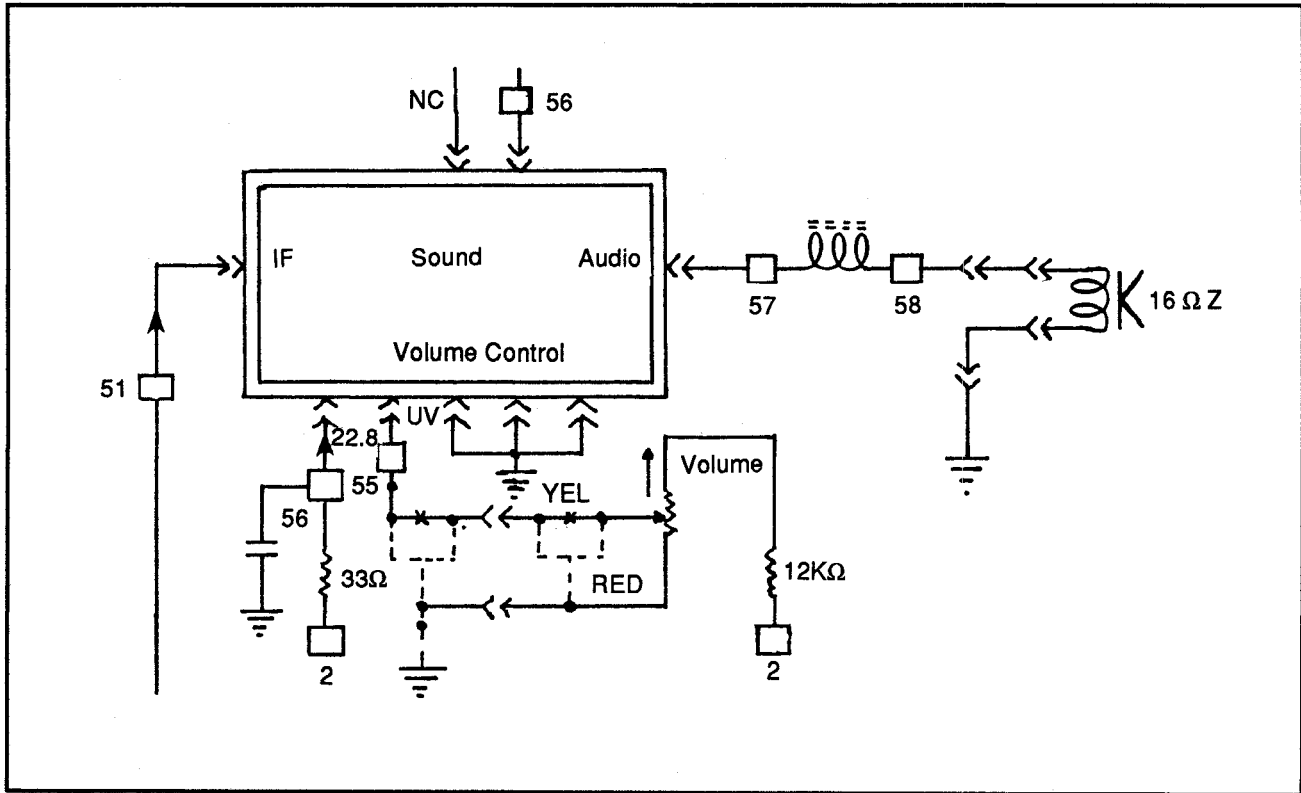


Figure 4: Sound module

module. Figure 5 shows the circuit for the AFT module. Connect the sweep generator to the TP on the VHF tuner. The sweep generator frequency will be 44 MHz (10 MHz sweep) and the marker generator frequency will be 45.75 MHz.

Adjust L3 on the AFT module for a maximum gain and symmetry of response. Adjust L2 on the AFT module for a crossover at 45.75 MHz. Refer to the waveform in Figure 6.

### 3.58 MHz Peaking Adjustment

To adjust the 3.58 MHz signal, tune in a good color signal either from a broadcast station or from the pattern/color bar generator. Connect the scope to TP5 on the chroma demodulator module and observe the 3.58 MHz signal. Figure 7 shows both the chroma demodulation module and the chroma processor module.

Adjust L1 on the chroma demodulator module to get the maximum amplitude of the 3.58 MHz signal. It should be about 1 V p-p (peak-to-peak).

Turn the videomatic switch to off and rotate the tint control (R303) to ensure that

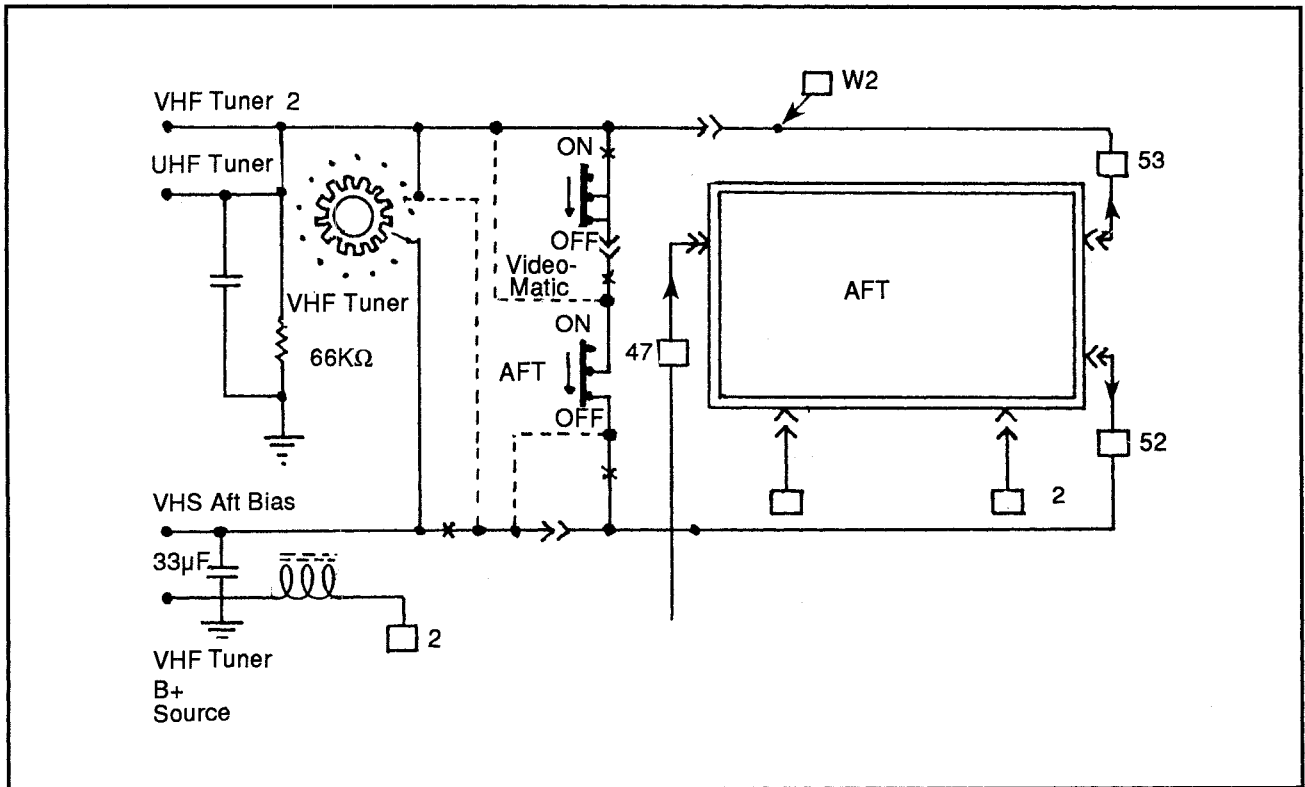


Figure 5: AFT circuit diagram

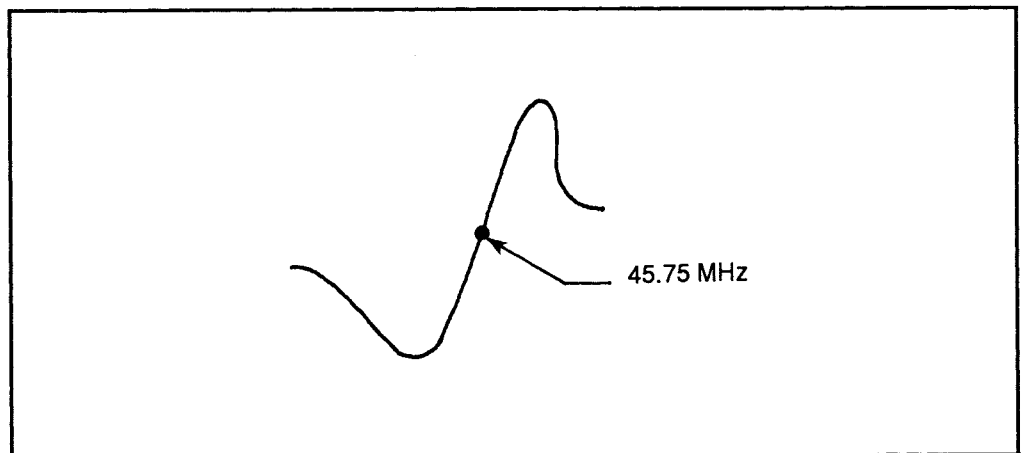


Figure 6: AFT waveform used for adjustments

the flesh tones can be shifted into green and into purple. L1 may need to be adjusted until a proper tint range is obtained.

# 6/TTV

Tube TV

6/TTV - VCS

Various Case Studies

6/TTV - VCS - Mag T985/T986

Magnavox

## 3.58 MHz Chroma Oscillator Adjustment

As before, set the TV to receive a good color signal. Turn the videomatic switch off and turn the color control fully clockwise. Connect a jumper between TP3 on the chroma processor module and ground.

The color killer control may need to be adjusted until color is obtained. This is R7 of the chroma processor module. Refer to Figure 7 for the chroma processor and demodulator as previously shown.

Adjust C5 until the color stops on the screen or has zero beat. Remove the jumper and readjust the color killer control if necessary.

## Color Killer Adjustment

Tune the TV to an unused channel. Turn the videomatic switch to the Off position. Turn the color control fully clockwise. The color killer control (R7) of the chroma processing module should be turned fully counterclockwise. Adjust the color killer control clockwise until color snow appears and then abruptly disappears. When this happens, the adjustment will be correct.

## Purity

The VHF tuner should be set between channels. Turn the videomatic switch to off and the contrast control fully counterclockwise. Turn the red background fully clockwise and the green and blue background controls fully counterclockwise. Adjust the brightness control to get the best possible red raster. Loosen the purity magnets by turning the locking ring about 1/4 of a turn clockwise. These are located on the neck of the CRT and will be the two tabs closest to the end of the neck. The locking ring will be closest to the coil around the tube neck. Spread the purity magnets until a uniform red is seen over the entire screen.

## Static Convergence

The pattern generator with a crosshatch generator pattern selected will need to be connected to the antenna terminals. Adjust the two convergence magnets, one and two (the next four tab rings behind the purity rings) to converge the blue and green vertical and horizontal lines. Adjust the next two convergence magnets (three and four) to converge the red vertical and horizontal lines. The magnets are numbered from the tube out toward the neck end.

## Gray Scale Adjustment

Tune the TV to an unused channel. Turn the videomatic switch to the Off position. Turn the brightness, contrast and color controls fully counterclockwise. Make sure the normal/service switch is set to the service position. The master screen control should be adjusted clockwise until one of the three colors is just visible. Turn the background controls of the other two colors clockwise until they are also just visible.

Reset the normal/service switch to the normal position and tune in a picture from

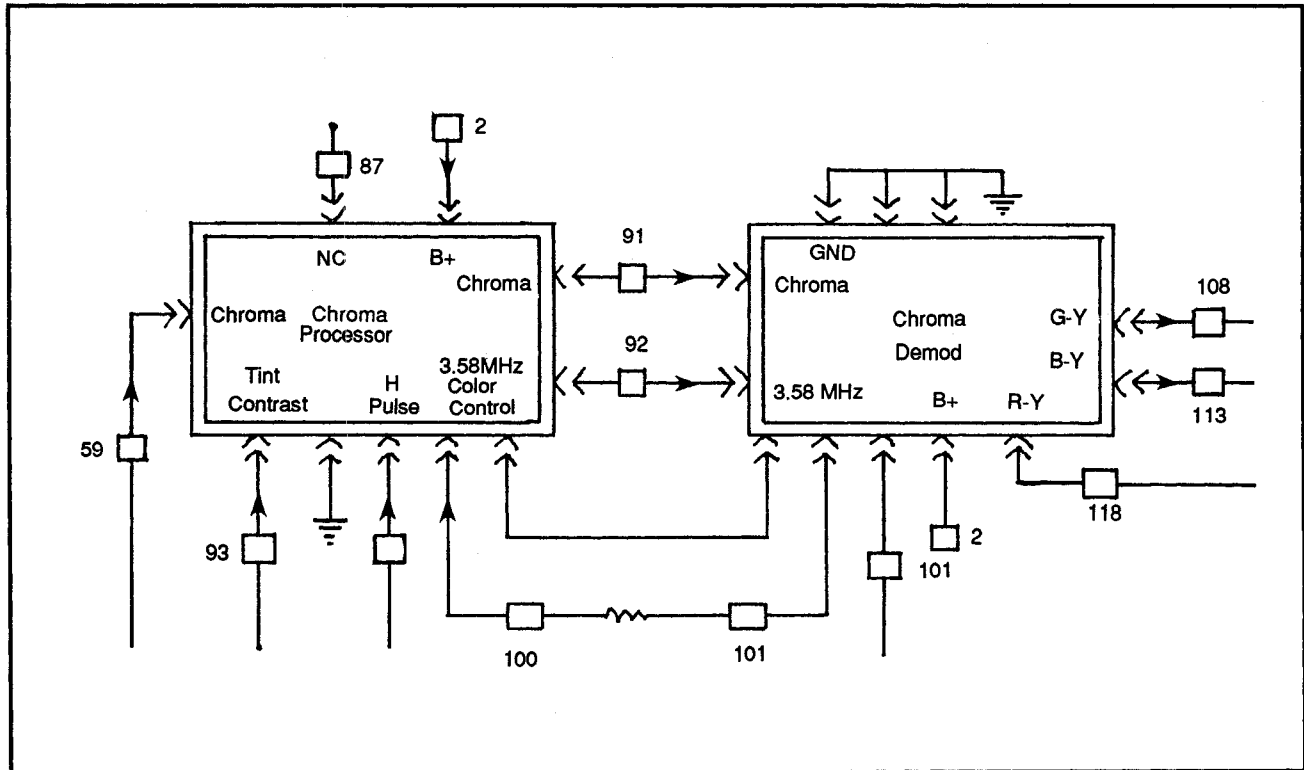


Figure 7: Chroma demodulation and chroma processor modules

a station or from the pattern color bar generator. Adjust the brightness and contrast to receive a dim black-and-white picture. If there is color shading visible in the low light sections of the picture, adjust the appropriate background control for a proper low light tracking setting.

Turn the brightness control up to a bright black-and-white picture level. If the highlights have color shading, adjust the appropriate drive controls to obtain a good highlight tracking control.

### Videomatic Range Adjustment

When the videomatic switch is on, the videomatic module determines how much effect ambient room light will have on the picture. To adjust this control, make sure the videomatic range switch is set to the On position. Have a good picture tuned on the screen.

Adjust the videomatic range control R4 for the best possible picture. The videomatic section is shown in Figure 8. A good color signal should be present on the TV screen. Press the videomatic switch S302. Adjust the preset brightness, color and tint controls for the best possible picture.

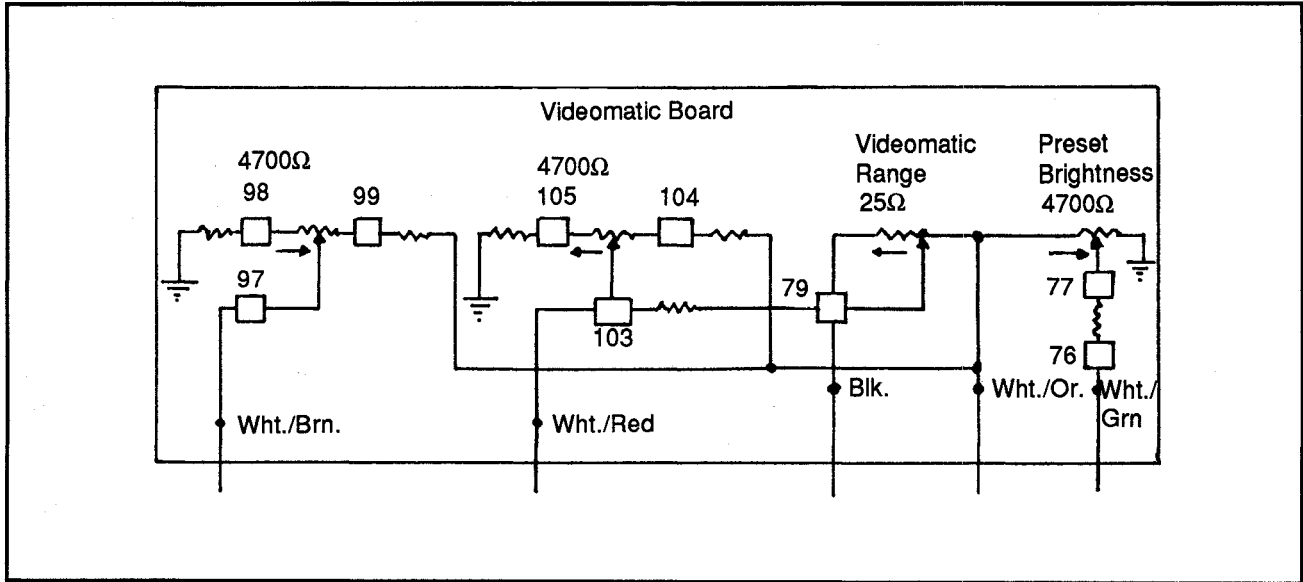


Figure 8: Videomatic module

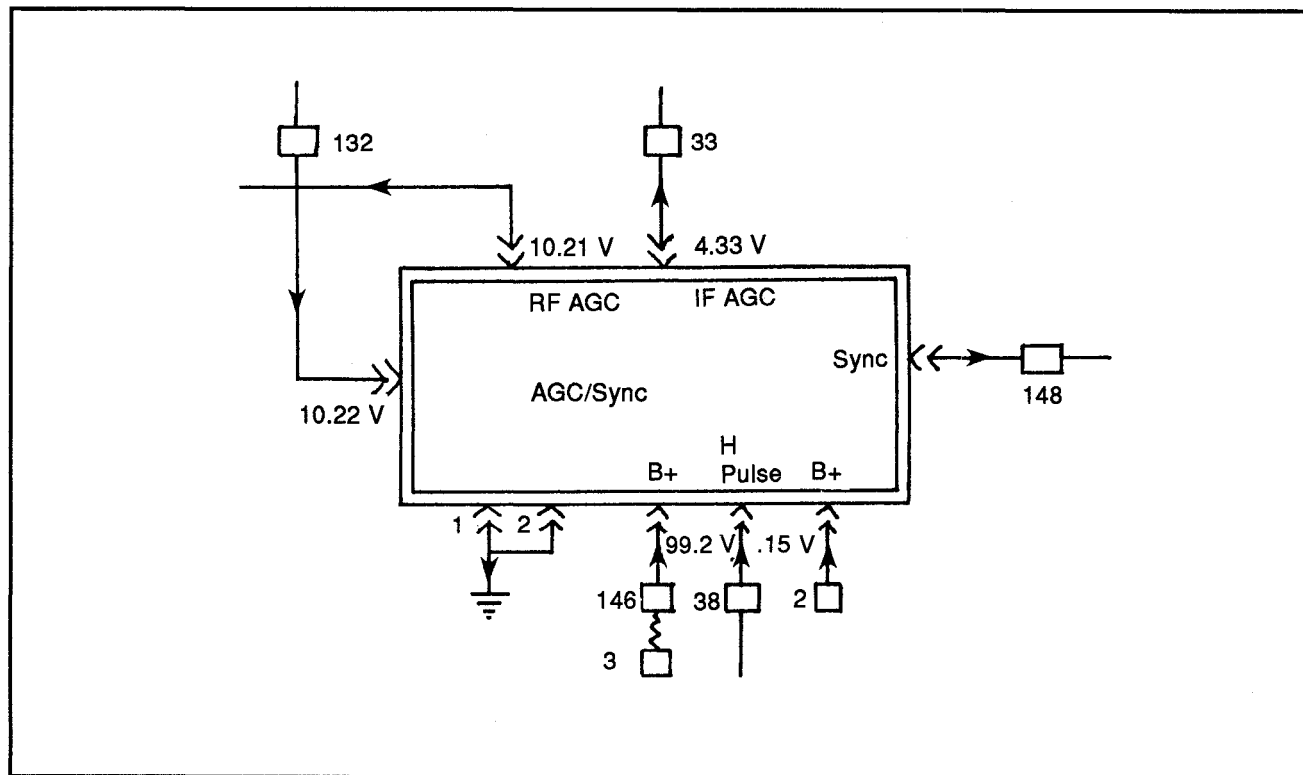


Figure 9: AGC/Sync module circuits



# 6/TTV

Tube TV

6/TTV - VCS

Various Case Studies

6/TTV - VCS - Mag T985/T986

Magnavox

**AGC Adjustment**

Again, a good picture is required from a local TV station. Adjust the RF AGC delay control R7 on the AGC/Sync module fully clockwise. Then turn the RF AGC delay control counterclockwise until the minimum amount of snow is received. Figure 9 shows the AGC/Sync module.

**B+ Adjustment**

This test requires the use of a DMM connected to W7. W7 is located at the power supply line, pin 4. Adjust R4 to read +24 V. Figure 10 shows a section of the circuit for the power supply.

**High Voltage Adjustment**

A high voltage probe should be connected to the CRT anode. Set the videomatic switch to the Off position. Adjust R10 of the power supply module for 24 kV at a minimum brightness. Be careful with this adjustment, for you are dealing with some very high voltage.

**Vertical and Horizontal Centering**

Tune in a station or inject a pattern from the pattern generator. Adjust the vertical centering control R19 to center the raster vertically. R19 is located on the vertical module which is shown in Figure 11.

A horizontal centering plug can be found on the main PC board. Place the plug in the position that gives the best horizontal centering.

**Horizontal Oscillator Adjustment**

Tune in a station and set the normal/service switch to the middle position. Adjust the horizontal hold R9 to get a minimum horizontal drift. This adjustment is located on the horizontal module and is shown in Figure 12.

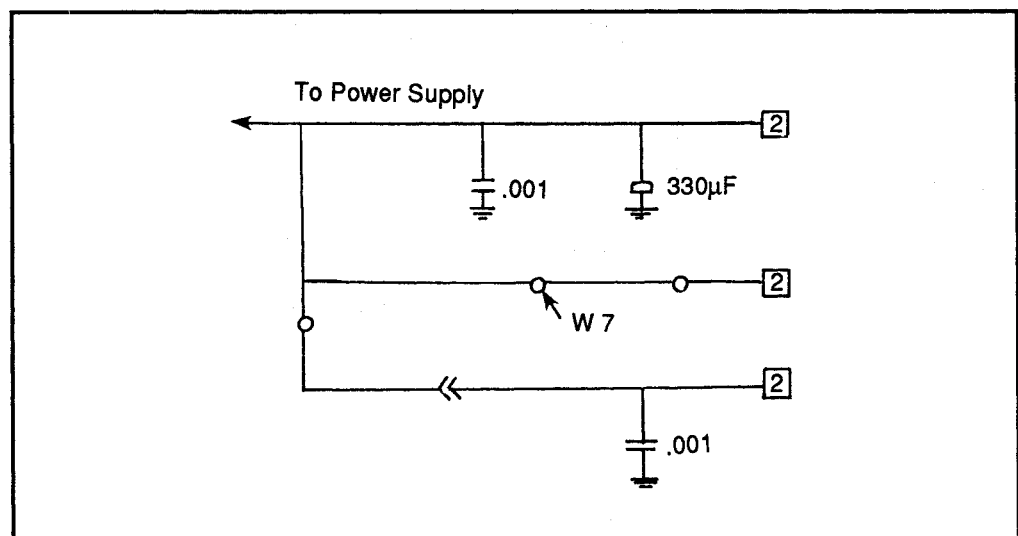


Figure 10: W7 24 V adjustment

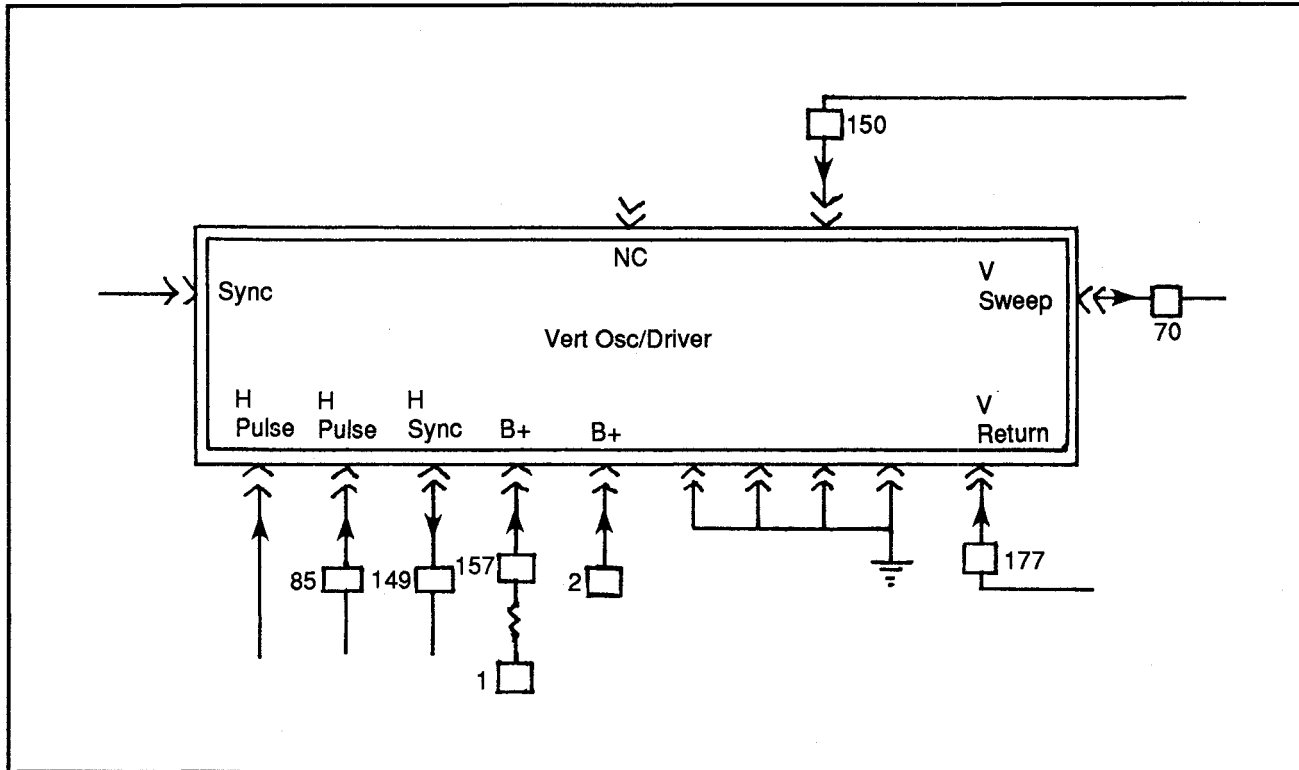


Figure 11: Vertical module circuit

## Tuners

The VHF tuner controls all the tuner outputs for both the VHF and UHF tuners. Both tuners are connected to an automatic fine tuning (AFT) module which makes fine adjustments for the two tuners. If the VHF tuner is not working, it may inhibit the functioning of the UHF tuner. If the UHF tuner is not working, it could be because of a bad VHF tuner, or bad UHF section on the VHF tuner. If both tuners work fine with the AFT turned off, but the image degrades with this control on, there is probably an AFT circuit malfunction.

Tuner adjustments are factory-set. If there is a major problem with the tuners that a general cleaning cannot cure, or if the replacement of a broken wire or part doesn't solve the problem, the tuner should be replaced as a whole.

### AFT Control Module

The automatic fine tuning (AFT) module is an IC-based controller with a few discrete components and three tuned coils. The module (when suspected as bad) should be swapped with another module for troubleshooting. If, however,

**6/TTV**  
Tube TV

6/TTV - VCS

Various Case Studies

6/TTV - VCS - Mag T985/T986

Magnavox

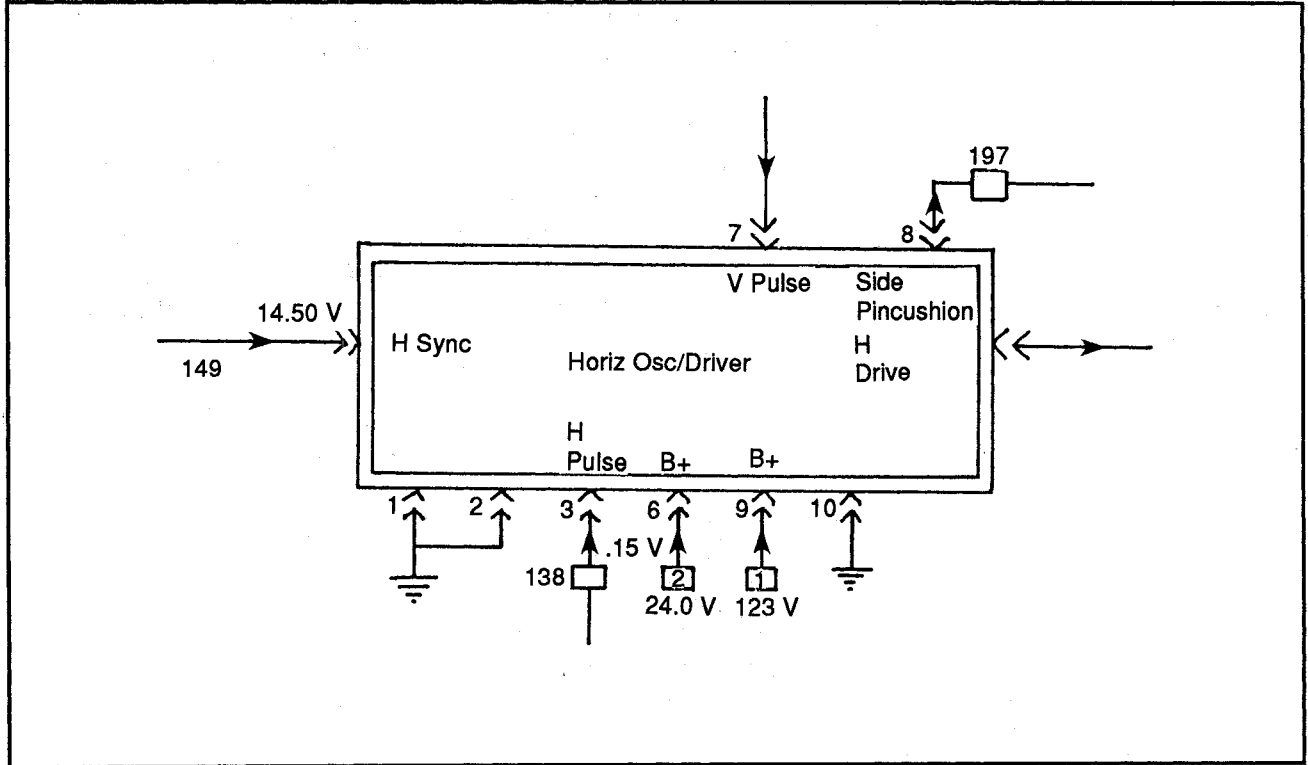


Figure 12: Horizontal module circuit

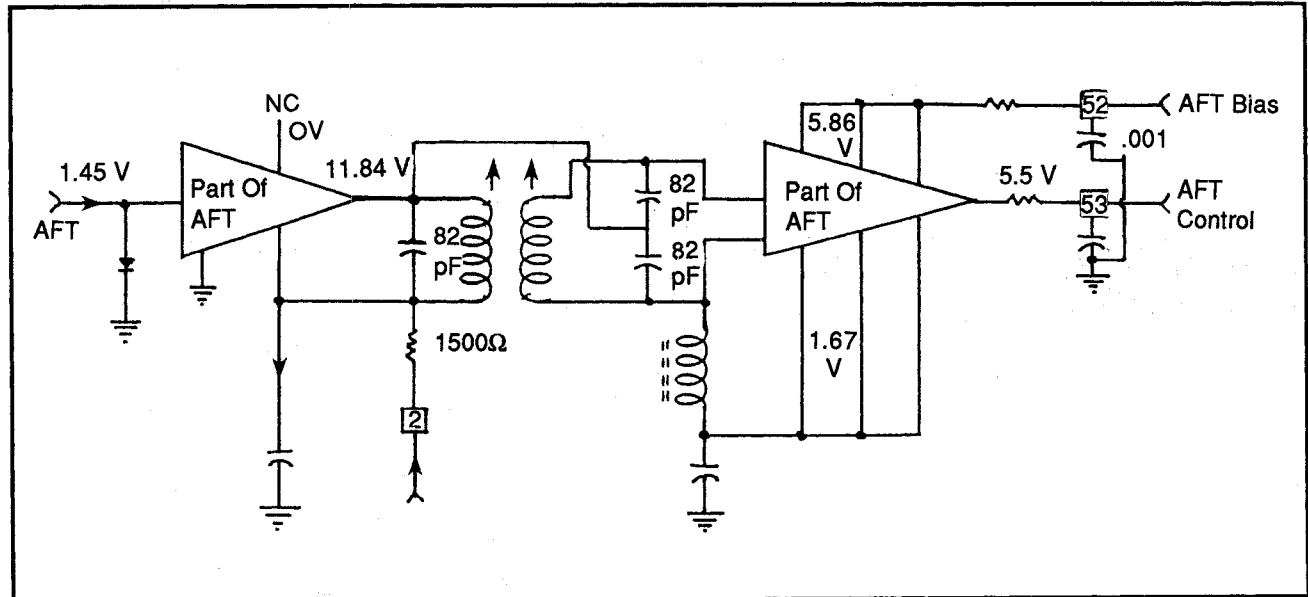


Figure 13: AFT circuit diagram

**6/TTV**  
Tube TV

---

6/TTV - VCS

Various Case Studies

---

6/TTV - VCS - Mag T985/T986

Magnavox

---

another module is not available, the following checks can be done. The IC may or may not be socketed for easy removal. If removed and not socketed, replace with a socket first before installing a new chip. (The IC is GE part GEIC-225 or Motorola equivalent HEPC6100P.)

If all the voltage levels check out for those to be found in Figure 13, the AFT circuit diagram, the module should be working. If not, replace the module.

---

# Section 7

## Audio

---

### Table of Contents

#### 7/A Amplifier

7/A - A	<i>An Introduction</i>
7/A - TR	<i>Troubleshooting and Repair</i>
7/A - TR - P	<i>Preamplifiers</i>
7/A - TR - SSA	<i>Solid State Amplifiers</i>
7/A - TR - TA	<i>Tube Amplifiers</i>

#### 7/CD CD Player

7/CD - F	<i>Features</i>
7/CD - F - CDD	<i>Compact Disc Design</i>
7/CD - F - CDPD	<i>CD Player Design</i>
7/CD - M	<i>Maintenance</i>
7/CD - TE	<i>Test Equipment</i>
7/CD - TR	<i>Troubleshooting and Repair</i>
7/CD - TR - A	<i>An Introduction</i>
7/CD - TR - CC	<i>Connections/Cables</i>
7/CD - TR - DD	<i>Disc Drawer</i>
7/CD - TR - DM	<i>Disc Motor</i>
7/CD - TR - L	<i>Laser Adjustment</i>
7/CD - TR - PM	<i>Pick-up Movement</i>
7/CD - TR - SP/AC	<i>Signal Processing/Audio Circuits</i>

#### 7/R Radio

7/R - F	<i>Features</i>
7/R - F - A	<i>Antenna</i>
7/R - F - M	<i>Modulation</i>
7/R - F - T	<i>Tuners</i>
7/R - F - T - AMT	<i>AM Tuners</i>
7/R - F - T - FMT	<i>FM Tuners</i>

---

---

---

---

**7/R - TR**            *Troubleshooting and Repair*  
**7/R - TR - A**            *An Introduction*  
**7/R - TR - Ch**            *Checklist*  
**7/R - TR - CT**            *Circuit Tests*  
**7/R - TR - DTR**            *Digitally Tuned Radios*  
**7/R - TR - R**            *Receivers*  
**7/R - TR - T**            *Transceivers*

**7/R**            *Receiver*

**7/R - VCS**            *Various Case Studies*  
**7/R - VCS - Tech ST-S8**    *Technics ST-S8*

**7/T**            *Tuner*

**7/T - VCS**            *Various Case Studies*  
**7/T - VCS - ZXP**            *Zenith XP Tuner*

**7/A**

Amplifier

7/A - A

An Introduction

---

---

## 7/A - A

### An Introduction

---

#### Tube Amplifiers

If you were called upon to repair a guitar-type amplifier—especially one of the newest ones—you might open the cabinet expecting to see high-power transistors mounted to large heat sinks to dissipate the energy. What you'll find could surprise you. Even today, many amplifiers use tubes and contain large power and output transformers, and filter capacitors.

One reason is that tubes handle high power easier than transistors. More important (as far as marketing), many musicians seem to prefer the sound.

What might be even more surprising is that the tubes being used aren't of some new or special design. You'll find standards, like 6L6, 5U4, 12AX7, etc. Unfortunately, these tubes are not made in the USA. They bear markings from Russia, China, Yugoslavia, and other former Eastern Block countries.

Here is "new" technology that has been caught in some type of time warp. It is stuck in the 50's. It's something that an older technician can repair without stretching the brain too much. Think of the tube as an FET with a light inside. It has high input impedance and medium output impedance and it is a voltage gain device.

One of the biggest changes in the construction of newer amplifiers, both tube and solid state, is the adoption of printed circuit boards. Not only do circuit boards allow cheaper construction, they standardize component layout and dress of the wiring. The disadvantage is that the boards are more subject to damage should the amplifier fall. Sudden jolts can easily crack the board and pop any number of circuit traces.

#### MIDI

When you find the specifications of a recent amplifier or pre-amplifier equipment listing MIDI (pronounced Mid-E) capability, or find a MIDI jack on the back of the equipment, you are now pushing the state of the art. MIDI (Musical Instrument Digital Interface) is the standard among manufacturers of amplifiers and manufacturers of other equipment such as music synthesizers. The MIDI is a means of tying together instruments, amplifiers, lights, and other special effects by the use of digital signals. For example, the interface could allow one keyboard artist to control several boards remotely. Included are memory devices that operate

equipment at certain times in a song. A computer, usually a Macintosh, can be tied to the system and can be used to drive the MIDI bus to activate equipment.

With an amplifier, for example, MIDI could replace footswitches with a computer generated on/off signal. Control could be set up to have a keyboardist control various parts of the amplifier rather than have the guitarist do that. The possibilities are unlimited when an amplifier has MIDI capability. In any event, with the MIDI design, expect to find more uses of the MIDI standard and expect to see microprocessor based digital equipment needing repairs.

**MIDI Standard**

The MIDI standard was established in 1982 in hopes that such a standard would make it easier for musicians to tie together the various building blocks of the music system. As a standard, MIDI calls for digital transmission of 8 bit serial codes at a data rate of 31,250 bits per second. Standard 5 pin DIN plugs are used to connect the cables. The codes tell each instrument whether to respond to the instructions or not (address bits). Every piece of equipment gets the same data stream. On the back of the equipment is usually a MIDI in jack, a MIDI out jack if the device is a controlling unit, and a MIDI thru jack for those pieces of equipment that don't regenerate the data stream. They simply shape the data up a bit and pass it on.

**Tools and Test Equipment**

The following tools and test equipment are needed when working with amplifiers:

VOM/DMM  
Tube Tester  
Transistor Tester  
Screwdrivers  
Nut Driver Set  
Soldering/Desoldering Tool



**7/A**

Amplifier

7/A - TR

Troubleshooting and Repair

7/A - TR - P

Preamplifiers

## 7/A - TR Troubleshooting and Repair

### 7/A - TR - P Preamplifiers

The primary function of the preamplifier is to amplify the low level signal from the pickup so that maximum power out of the amplifier can be obtained. It is also where the dirty work of mixing in tremolo and reverberation is done. The preamplifiers are generally straightforward tube or transistor voltage amplifiers. Separate units are available in addition to those included as part of a combined amplifier/speaker unit.

Amplification levels are such that the gain of the preamplifier can be adjusted to achieve distortion while the power amplifier volume control is reduced to control the sound level out of the loudspeakers.

#### Tube Preamplifiers

Figure 1 gives a typical schematic for a tube-type preamplifier. Dual jacks are provided for each channel. Having two channels allows the preset of the tone controls for each. Each type needs its own setting in the tone controls. Other than this, both channels are essentially identical.

Although identical in other respects, only channel 2 has reverberation and tremolo capabilities. Immediately after the input jack, the signal is fed to the grid of tube V1, a voltage amplifier. It also goes to the grid of tube V2, another voltage amplifier. From V2 the signal is capacitance coupled to the tone network consisting of 3 capacitors, 3 resistors and a midrange tone control. This control sets the slope or frequency response of the amplifier. From this network the signal is passed to a volume control, the center tap of which goes to the grid of amplifier tube V3.

#### Bass Control

The signal is passed to another tone network that primarily affects the lower range of frequencies. This is the bass control. It also feeds the treble network and control and affects the upper range of frequencies. The value of capacitors identifies

**7/A**  
Amplifier

7/A - TR

Troubleshooting and Repair

7/A - TR - P

Preamplifiers

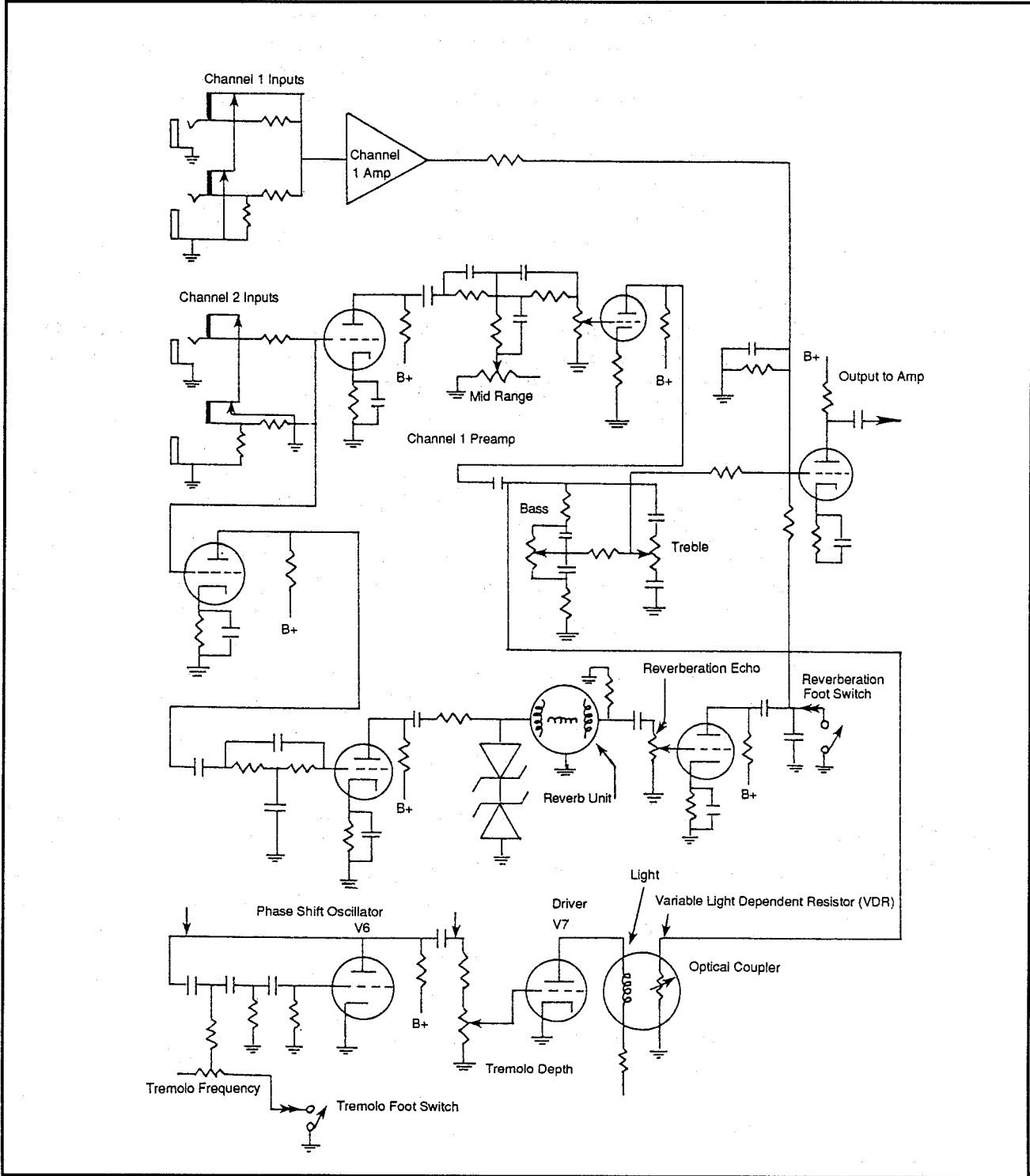


Figure 1: Tube-type preamplifier

# 7/A

Amplifier

7/A - TR

Troubleshooting and Repair

7/A - TR - P

Preamplifiers

the frequency range of each network. The lower value capacitors are in the treble range while the larger capacitors are in the bass range.

From these two controls we feed the signal through an isolation resistor into the power amplifier. At this point the output of channel 1 and the reverberation circuit are combined.

Backtracking to the input of the bass/treble networks a signal is inserted from the tremolo circuit. A varying resistor in the tremolo circuit varies the signal level at that point.

## Reverb Unit

The signal from the input jack through tube V1 is fed to amplifier V4 and then to the reverberation unit. The function of this device is to delay the audio signal so that when it is mixed with the normal signal we can obtain an echo type signal. To do this a coiled spring is driven by V4. The spring vibrates and when the signal reaches the other end it is converted back into an electrical signal. Reverberation is caused by the mechanical delay of the spring compared to the electrical signal. From the spring, the audio signal is fed to the reverb/echo control which is a simple volume control. The signal is amplified and combined with the other outputs into the power amplifier through the 470 K resistor. A foot switch between the reverb amplifier and the 470 K resistor simply shorts the reverb signal to ground.

## Phase Shift Oscillator

Tube V6 is a phase shift oscillator. The capacitor-resistor network between the grid and cathode of V6 determines the frequency of the oscillations. These oscillations are in the 4 to 14 Hz frequency range. Frequency is set by the potentiometer which is part of the network.

A foot switch controls the operation of the oscillator by opening one leg of the potentiometer. The value of the resistors and capacitors is critical to maintain oscillation. If the oscillator won't function after changing the tube, measure the value of each of the components. If you can't measure capacitance then you must substitute parts. Use known good parts with the best tolerance you can find.

An oscilloscope connected to the output (plate) of tube V6 is the only way to determine if the circuit is oscillating. If you can get it to run at all, bridge small values of capacitance across any of the three capacitors in the network and try to increase the signal level to obtain reliable starting of the oscillator. Older capacitors, although sealed units, often pick up moisture and change value, resulting in an oscillator that doesn't start.

From V6 the signal is fed through a level control into tube V7. The level control

**7/A**

Amplifier

7/A - TR

Troubleshooting and Repair

7/A - TR - P

Preamplifiers

adjusts the level of the low frequency signal and is known as the tremolo depth control.

**Optical Coupler**

From the plate of V6 the signal is fed into an optical coupler consisting of a lamp and a light sensitive resistor mechanically connected together and shielded from outside light. The light follows the signal from the tremolo oscillator. This in turn varies the resistance of the coupler which follows the oscillator output. As mentioned before, this resistor is connected to the signal of channel 2 at the bass and treble control. As the resistance varies and follows the tremolo output, the signal out of channel 2 varies.

**Solid State Preamplifiers**

The block diagram of a solid state preamplifier is virtually identical to the tube versions. The only difference is in the use of transistor circuitry versus tube circuitry. Older solid state preamplifiers use transistors while newer versions employ operational amplifiers as the amplifying and frequency response shaping circuits.

Figure 2 gives the schematic of a transistorized preamplifier. As with the tube preamplifier there are two channels which are more or less the same. Channel 2 provides the tremolo and the reverberation capabilities. The output of channel 1 and channel 2 are combined in transistor Q11 and Q12. From there the signal goes to the power amplifier.

The input signal from the pickup is connected into the channel 2 input jack if the reverb and tremolo features are to be used. This input jack is connected to a darlington pair transistor input amplifier Q1 driving an emitter follower transistor Q2.

The transistor isolates the input amplifier from the load of the midrange volume control part of network 1. This network shapes the midrange frequency response. At the output of this network, where it is connected to the feedback Q3 and output Q4 preamp sections, is a signal from the output of an optical coupler of the tremolo circuit. As in tube tremolo circuits, a phase shift oscillator generates the low frequency oscillations.

A transistor oscillator Q5 feeds driver Q6 which drives the lamp portion of the optical coupler. The tremolo foot switch grounds the output of the oscillator Q5. A control at this point allows the guitarist to set the amount of tremolo.

**Feedback Preamp**

The feedback preamp Q3 and output preamp Q4 are tied together with network 2, the bass and treble controls. The signal is fed into an isolation amplifier Q7.

**7/A**  
Amplifier

7/A - TR

7/A - TR - P

Troubleshooting and Repair

Preamplifiers

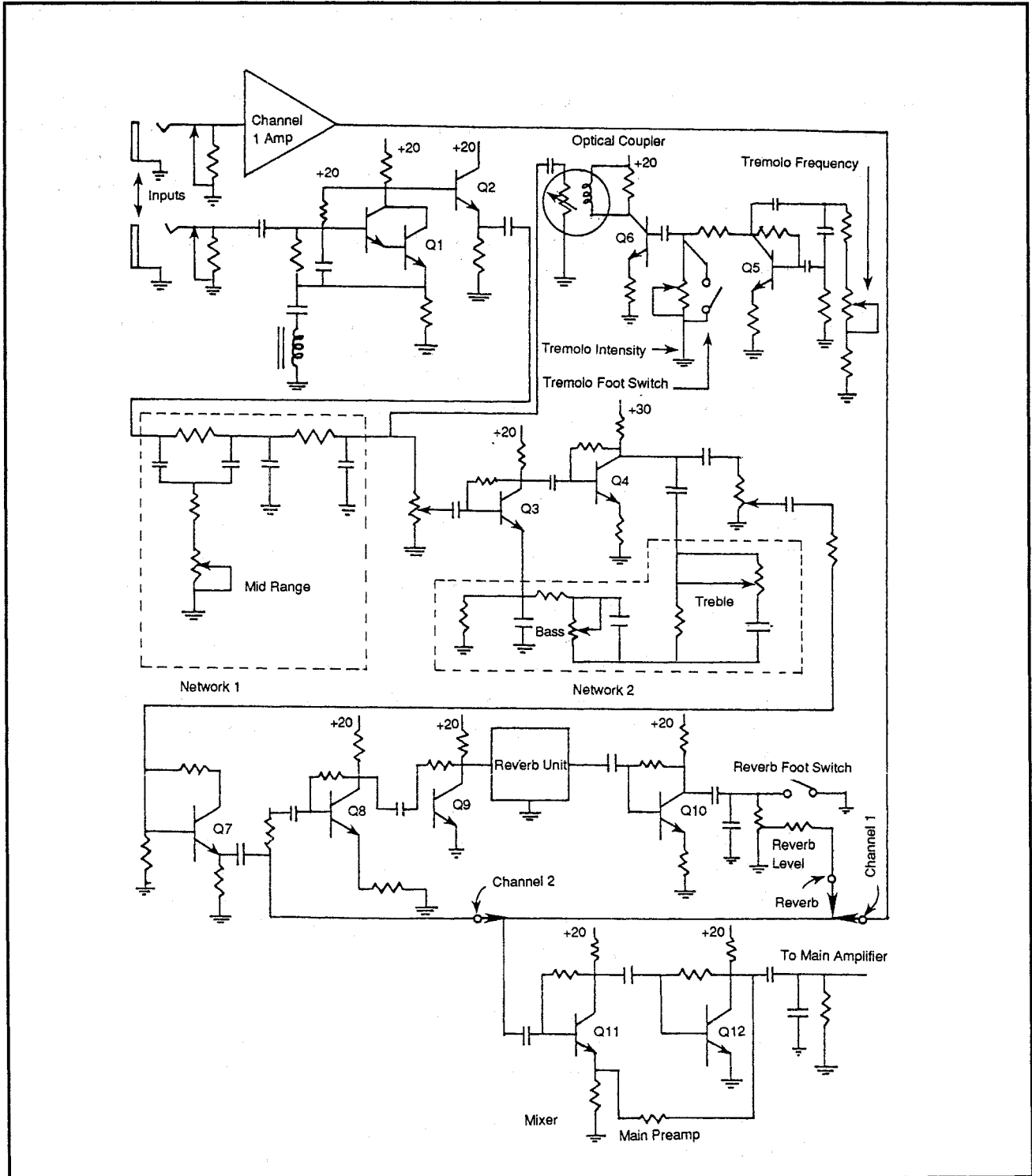


Figure 2: Solid-state preamplifier

**7/A**  
Amplifier

7/A - TR

Troubleshooting and Repair

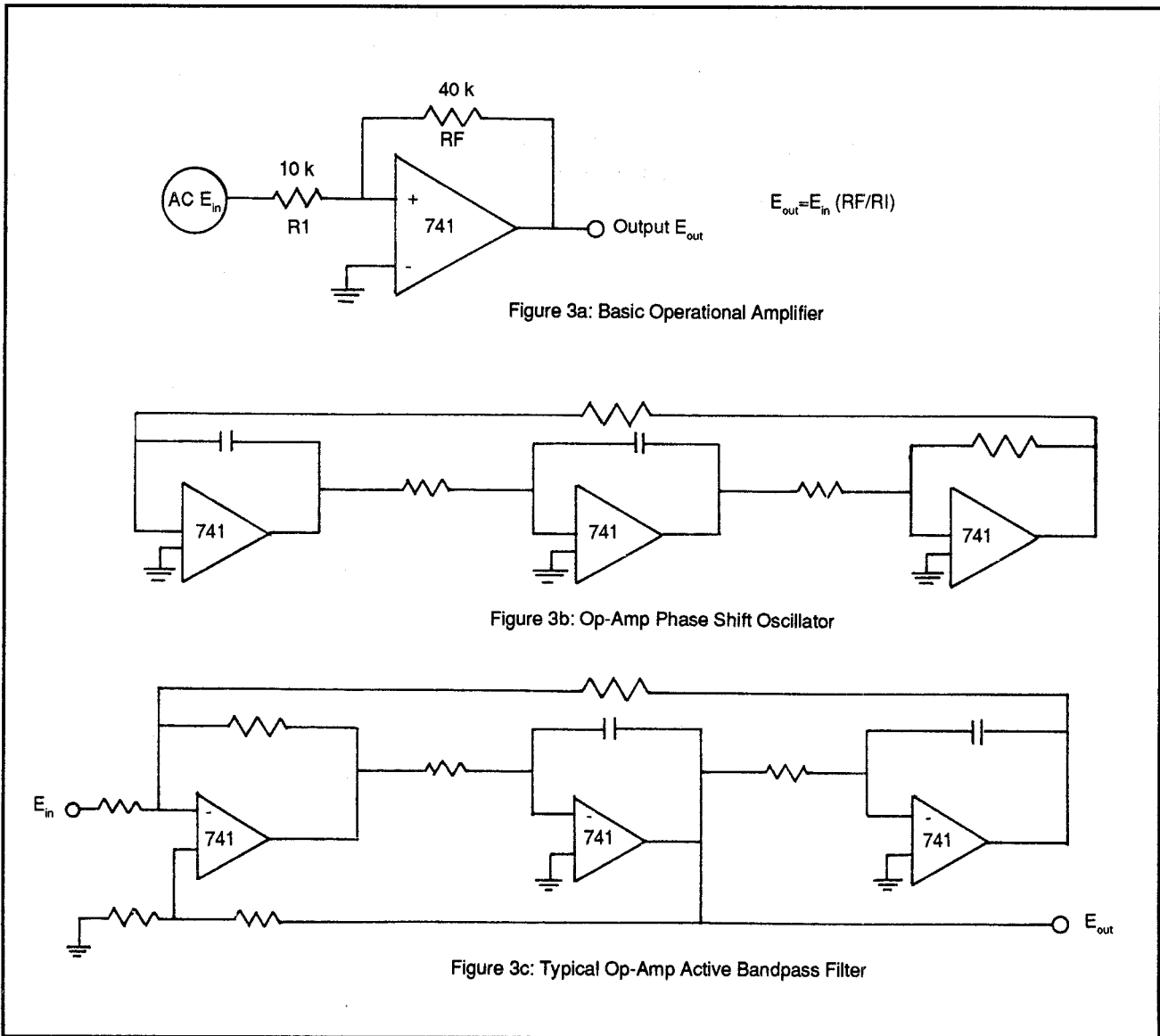
7/A - TR - P

Preamplifiers

From there the signal goes to transistors Q8 and Q9 which drive the spring re-  
verberation unit. Output is amplified by the circuit of transistor Q10 which has  
a reverberation level control at its output. Across this control is the reverberation  
foot switch which simply shorts out the reverberation output if it isn't needed.

**Op-Amps**

Figure 3 shows several typical circuits of integrated circuit operational ampli-  
fiers. These op-amps replace almost all of the transistors in later model solid state  
amplifiers. Type MC-1741 amplifiers are used in their various multiple pack-



**Figure 3:** IC operational amplifiers

**7/A**

Amplifier

---

7/A - TR

Troubleshooting and Repair

---

7/A - TR - PPreamplifiers

---

ages. Type MC-1741 are dual 741's in one package while MC-4741 gives us four 741's in one package.

Operational amplifiers are the basic amplification building blocks of linear integrated circuits. Figure 3a shows a type 741 connected as a simple amplifier. The gain of the circuit can be estimated by dividing the value of the feedback resistor from the output to the input by the value of the resistor in the input. In the circuit shown, the gain is approximately 4. Figure 3b is the diagram of a sine wave oscillator found in a tremolo circuit. Figure 3c is a simple bandpass amplifier/filter that might be found around a bass or treble control. Note the presence of feedback loops. Those are similar to what you might find in a solid state preamplifier using ICs.

In the newer solid state preamplifier circuits, FETs are often found being used as series switches to select channels as well as options such as reverberation and tremolo. The FETs give a quieter switching response than the footswitch connection directly into the circuit.

**7/A**  
Amplifier

---

7/A - TR

Troubleshooting and Repair

7/A - TR - P

Preamplifiers

---



# 7/A

Amplifier

7/A - TR

Troubleshooting and Repair

7/A - TR - SSA

Solid State Amplifiers

## 7/A - TR

### Troubleshooting and Repair

## 7/A - TR - SSA

### Solid State Amplifiers

Figure 1 shows the schematic diagram of a generic solid state guitar power amplifier. In this case a coupling transformer is used between the driver transistors and the output transistors.

Newer amplifiers use more fancy bias schemes to eliminate this transformer. Some of the older transistor amplifiers had two sections—a bass section driving 16  $\Omega$  “woofers” and a treble section driving 8  $\Omega$  horns or “tweeters.” The two amplifiers are virtually identical and only one is shown. As in the tube amplifiers, access to the power amplifier is through a jack that bypasses the preamplifier.

#### NPN Amplifier

The signal is fed from the input jack or the preamplifier to an NPN transistor voltage amplifier Q1. Linearization of this amplifier is done with a feedback loop from the output of the power amplifiers. A driver transistor Q2 provides current gain to drive the driver transformer. This configuration is a grounded collector PNP direct coupled to the voltage amplifier.

The NPN output transistors are arranged in darlington pairs with the proper phasing determined by the driver transformer. Separate bias adjustments are available for each pair of transistors. Power for the bias potentiometer is from the B+ and B- supplies through resistors R1 and R2 and the diodes D1-D4 and zener diodes Z1 and Z2. The DC voltage at the point where the two darlington pairs are connected should be approximately zero. One side of the loudspeakers is directly connected at that point with the other side going to ground.

If a transistor is not biased properly, the voltage may damage the loudspeaker, or blow it out. A slight DC voltage at this point may bias the position of the loudspeaker cone either in or out resulting in some distortion. Be careful in arbitrarily readjusting these bias pots. The distortion of the speaker may be what the guitarist wants. You may be better off leaving things as is unless you are trying to fix a problem in the power amplifier.

**7/A**  
Amplifier

7/A - TR

Troubleshooting and Repair

7/A - TR - SSA

Solid State Amplifiers

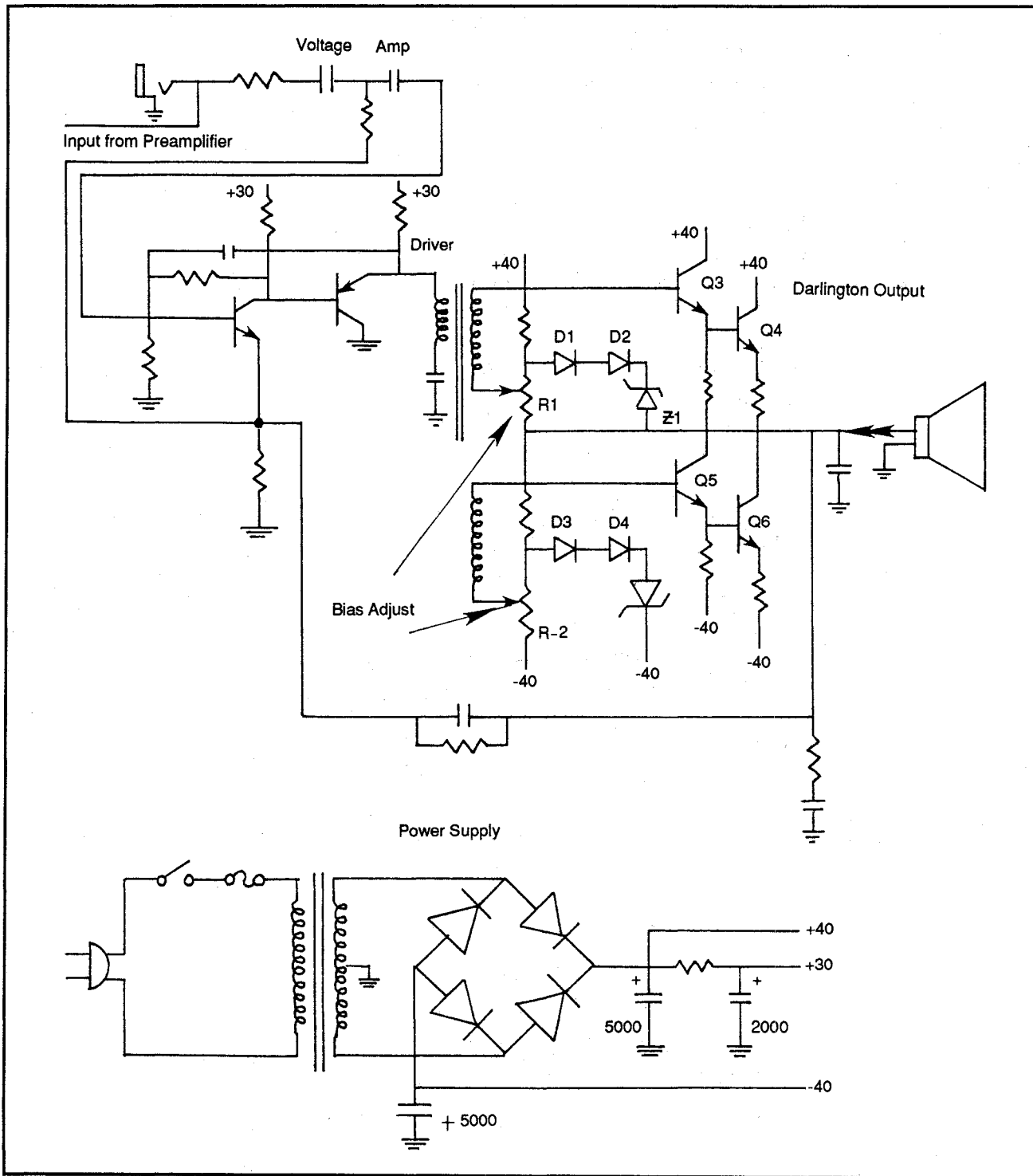


Figure 1: Solid state amplifier schematic

**7/A****Amplifier**

7/A - TR

Troubleshooting and Repair

7/A - TR - SSA

Solid State Amplifiers

In solid state amplifiers that have only one power supply, the junction point of the output transistors is at a point which is approximately 1/2 the B+ voltage. Instead of direct connection, loudspeakers are connected to the amplifier output through a large electrolytic capacitor. This eliminates the DC being passed to the loudspeaker.

The method used to bias the transistors is not always clear on a schematic. Manufacturers use some clever schemes to get this bias. About all you can do is check the value of the various resistors to determine if they are within the tolerances marked on them. Transistors are usually go/no-go devices. They seldom "age" and change values.

Before adjusting any potentiometer, be sure of what you are doing. Service information is indispensable. It is often best to leave adjustments alone.

The power supplies for transistor power amplifiers are usually of the bridge type, enabling the generation of both positive and negative voltages. Current requirements for each polarity are similar since the current "hogs" are the darlington output pairs.

As described in the section on tube amplifiers you should be very careful when using a variac for testing a transistor amplifier. As the voltage is raised, the bias on the various transistors changes dramatically as transistors start to draw current. Don't be surprised if nothing works right until you approach the normal operating voltages. The light bulb test is good to protect an amplifier that you suspect has a shorted transistor.



---

7/A - TR

Troubleshooting and Repair

---

7/A - TR - SSA

Solid State Amplifiers

---

# 7/A

Amplifier

7/A - TR

Troubleshooting and Repair

7/A - TR - TA

Tube Amplifiers

## 7/A - TR

### Troubleshooting and Repair

## 7/A - TR - TA

### Tube Amplifiers

Figure 1 is a schematic diagram of a generic power amplifier. Although all amplifiers differ, only minor changes are made from year to year. Figure 2 shows the base pinout of some of the most common tubes. This, too, remains the same.

Most amplifier units contain preamplifiers in addition to the main power amplifier. Some power amplifiers are wired directly to the preamplifier while others have a jack available so the power amplifier can be used by itself. The audio from the preamplifier or an external source is fed through capacitor C1 into the grid of a triode amplifier. Resistor R1 provides bias for this amplifier from the bias source established by resistors R2-R4. The cathode of this first section is directly connected to the cathode of the second section of the same tube (V1). The grid is AC grounded through capacitor C2. The pair comprise a cathode coupled phase inverter. The result is a signal through C3 to output tube V2 which is 180 degrees out of phase with the signal through C4 to output tube V3.

#### Bias

Bias on the output tubes is adjustable through potentiometer R7 and resistor R8 from the negative voltage source consisting of diode D1 filtered by electrolytic capacitor C5. If the bias voltage is reduced, more current will be drawn through the output tubes. Saturation will occur at lower signal levels. If the bias is set too high, the tubes can effectively be cut off, requiring more signal level to reach saturation.

The screen grids are connected to a B+ source through resistors R9 and R10. Output from the plates of the tube are fed to the loudspeakers through output transformer T2. A bit of feedback is applied from the secondary of the output transformer to the bias network of tube V1 to prevent oscillations. So far this is standard and found in any high fidelity amplifier since the 1950's. The main difference is the B+ voltages applied to the output tubes.

This is approximately 460 V and is well above the normal operating range for this tube type, but is below the maximum rating of 500 V. These high voltages are necessary to get the needed 50 W of power out of the unit.

**7/A**  
Amplifier

7/A - TR

Troubleshooting and Repair

7/A - TR - TA

Tube Amplifiers

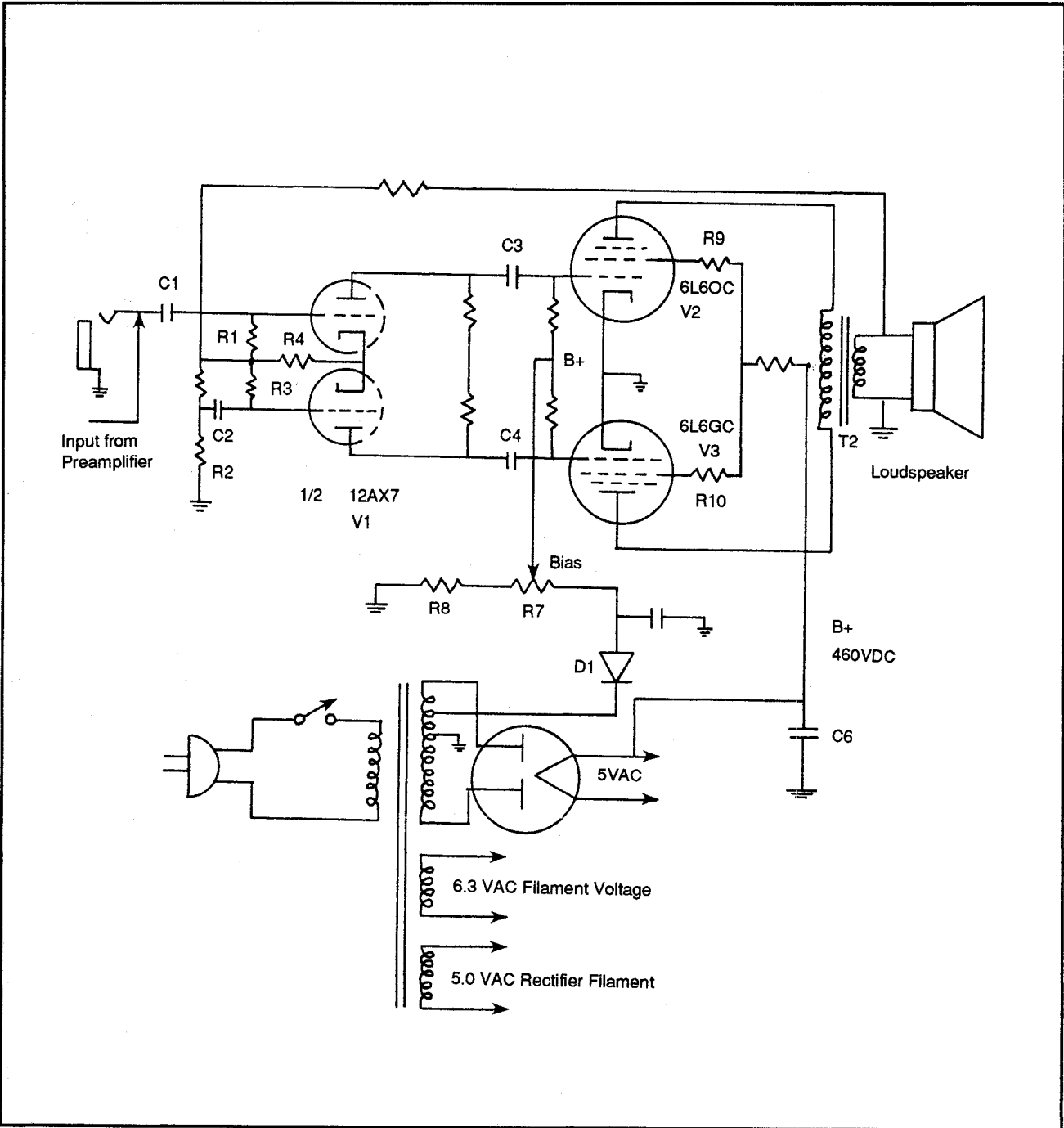


Figure 1: Power amplifier schematic



7/A - TR

Troubleshooting and Repair

7/A - TR - TA

Tube Amplifiers

**Warning!**

*It's important to keep in mind that these circuits are not low-power transistor circuits. Keep safety in mind for you and your test equipment.*

The power supply design is straightforward with a full wave rectifier into a simple filter capacitor C6. As with the tubes, this capacitor is often stressed by high voltages.

**Power Transformer**

A fuse or circuit breaker, power switch and line cord make up the primary circuit to the power transformer T1. For the non-tube technicians, the other winding on the power transformer provides the filament voltage to heat the cathodes of the tubes. When heated, the cathode emits electrons which are drawn to the plate by the positive voltage on the plate of the tube. On the way to the plate they pass through the control grid. The negative bias voltage and the signal voltage on this grid vary the number of electrons that reach their destination, the plate. A small change in voltage on the grid causes a large voltage change on the plate. In simple terms this constitutes signal amplification.

**Electron Emission**

After a period of use, the electron emission of the cathode of a tube drops off, resulting in decreased amplification from the tube. Output tubes are usually replaced in pairs using the same manufacturer and manufacturing date. Often they are sold in pairs with the boxes of the tubes taped together. To determine the quality of a tube, a tube checker is used. This checker measures the gain of the tube.

**Flakes**

Tubes are also subject to noise caused by flakes of cathode material or material used in manufacturing. These flakes find their way into the spaces between the various elements.

**Microphonic**

Tubes can also get "microphonic". This is a vibration of the elements causing a ringing sound if the tube is tapped while in use. Feedback from the speaker can also cause microphonics in preamplifier tubes. Sometimes these flaws can be found by a tube tester, but a simple listening test is best. Replace any tubes that test bad or have noise or microphonic problems.

**Leakage**

Because of the close tolerances between the filament and its surrounding cathode, leakage or even a dead short between the two is not uncommon. The result is a hum that goes away once the tube is removed from the socket. Many amplifiers have a "hum" potentiometer across the filament winding with the center arm of the pot going to ground. This adjustment is usually done once at the factory, but since it is readily accessible from the rear of the chassis, there is a good possibility that it may have been turned. Try rotating the pot from stop to stop and set it for the least hum.

**7/A**  
Amplifier

7/A - TR

Troubleshooting and Repair

7/A - TR - TA

Tube Amplifiers

Most tubes are now imported. The available stock may be listed in the various electronics magazines. Often the owner of the equipment has a preference for a certain brand of tube. For example, claims are made that 6L6's from China have better sound than ones from Russia and vice versa.

**Capacitors**

High voltage electrolytic capacitors used in tube-type amplifiers are getting harder to find. If you have new ones that have been around for a while be sure to "reform" them before applying full voltage. This is done by the gradual application of a DC voltage. You have to limit the current being applied so they don't overheat. This is where your old "condensor" or capacitor checker can earn its keep by measuring not only capacitance but electrolytic leakage.

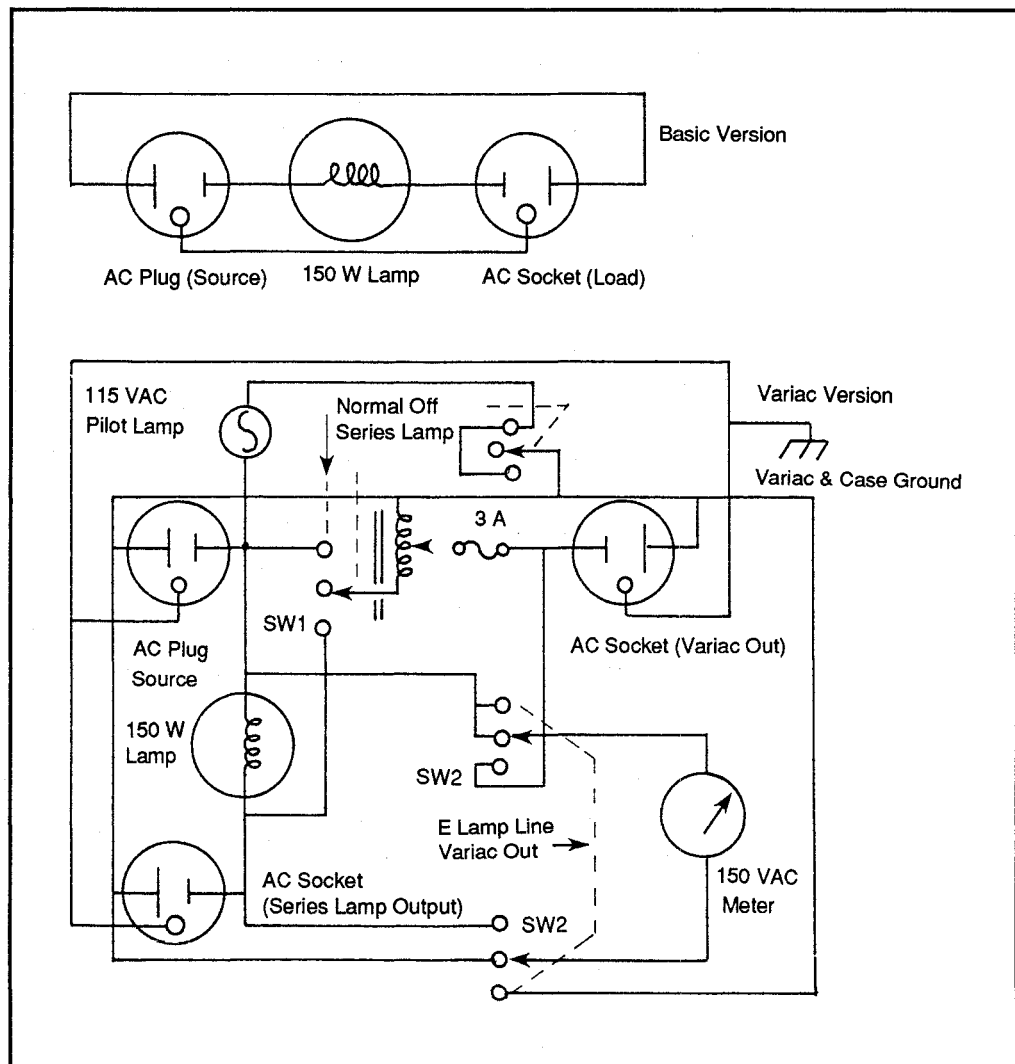


Figure 2: A simple amplifier output tester



**7/A**  
Amplifier

7/A - TR

Troubleshooting and Repair

7/A - TR - TA

Tube Amplifiers

If the problem in the amplifier isn't immediately obvious and the case appears dented or damaged, pull the chassis and look at the circuit board with a good magnifying glass. Search for cracks in the board or in the circuit traces. If there is a crack, patch the board with epoxy cement and bridge the broken circuit traces with wire, flowing solder onto both sides of the trace and the wire.

Figure 2 shows a simple circuit that needs to be the part of every work bench. It uses a high wattage light bulb in series with the load which, in this case, is the amplifier. The amplifier should be plugged into this circuit before it is ever plugged into the wall outlet. If something inside the amplifier is shorted it will blow fuses. With this test circuit in place the worst thing that can happen is that the light bulb lights up.

After repair it is a good idea to again run the amplifier through the light bulb before trying it directly into the wall outlet. The bulb should barely glow if everything is OK. With a little experience you can judge the proper operation of any electronic device. It is particularly useful for the hobbyist that is rewinding a power transformer. Add a variac and a meter to the circuit and you have a versatile unit.

**Field Coil**

Some older loudspeakers had a field coil instead of a permanent magnet. The field coil was connected in the power supply as a filter choke. The DC flowing in the coil made the coil and surrounding metal into an electromagnet. You may encounter these in some of the older amplifiers with separate speakers. In such cases, when the connecting plug between the speaker and the amplifier is pulled out, not only is the speaker disconnected but the power supply is disabled. This prevents the output from the amplifier from causing damage from a lack of a speaker load.

Separate speakers using PM magnets use plugs with a shorting wire across two of the pins. Again, the purpose of the wire is to disable the power supply when the speaker is unplugged.



---

7/A - TR

Troubleshooting and Repair

---

7/A - TR - TA

Tube Amplifiers

---

# 7/CD

## CD Player

7/CD - F	Features
7/CD - F - CDD	Compact Disc Design

## 7/CD - F

### Features

## 7/CD - F - CDD

### Compact Disc Design

A compact disc (CD) is a laser-read (also termed optically-read), data storage device on which audio, video, or computer encoded material can be stored.

A CD is made of an optically clear, flat plastic which is then stamped (while soft) on the upper surface from a nickel-plated mold that is a negative of the original recording. After the disc is stamped, the pattern of pits and flats is coated with a molecule-thick layer of reflective aluminum, overlaid with a protective coating of lacquer, and covered by the printed label.

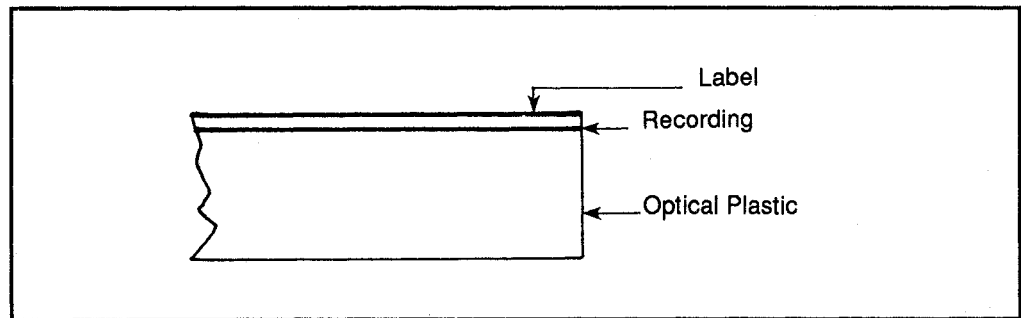


Figure 1: Cross section of a CD

The CD is 12 cm in diameter (4-23/32"), and has a thickness of 1.2 mm. The diameter of the CD is divided into several sections. The center hole is 15 mm across. Around it is a spindle support area with a diameter of 50 mm. The storage area extends from the outer perimeter of the support section almost to the edge of the disc.

The storage area is about 1/6 that of a phonograph record and only one side of the disc is used for this purpose. This allows a CD to hold up to 79.8 minutes of 2-channel (stereo) music and up to 99 tracks or selections.

**7/CD**  
CD Player

7/CD - F

Features

7/CD - F - CDD

Compact Disc Design

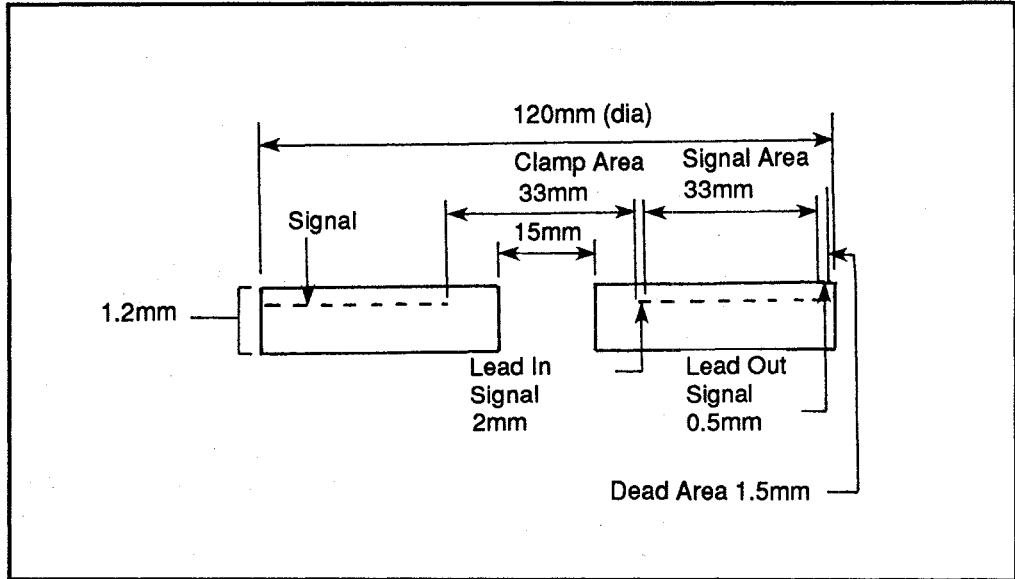


Figure 2: Physical dimensions of a CD

**Pits and Lands**

The compact disc recording consists of pits (depressions) and lands (the areas between the pits). These are commonly referred to as the tracks on a CD. When read by a laser, the transitions between the pits and the lands are converted to binary numbers of 1 and 0.

A common misconception is that the laser collects its information from the actual

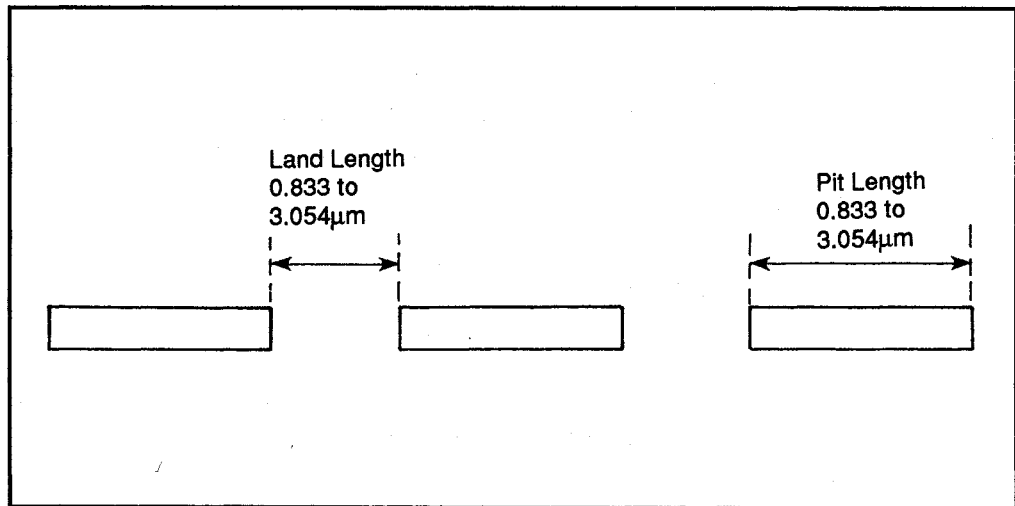


Figure 3: Illustration of pit dimensions

# 7/CD

## CD Player

7/CD - F	Features
7/CD - F - CDD	Compact Disc Design

pit or land, the pit being a binary 0 and a land corresponding to a binary 1. In reality, it is the transition which causes the change from 1 to 0 or 0 to 1.

Each pit is approximately 0.1 micrometer ( $\mu\text{m}$ ) thick, 0.5  $\mu\text{m}$  wide and about 0.2  $\mu\text{m}$  deep. (1  $\mu\text{m}$  is one-millionth of a meter, or 1/25,000 of an inch.) This spacing causes light to be diffracted in a colorful rainbow spectrum.

To give you an idea of how narrow these “tracks” are on a compact disc, about 60 pits and lands (also called flats) can be put in the area occupied by a single groove in an LP record. On the average, a CD will have about 60 minutes of audio with some 20,000 tracks in its signal area (the area of the disc which holds the actual music).

A disc rotates initially at 500 revolutions per minute (rpm) and gradually slows to about 200 rpm as the spiral track approaches the rim. During playback, a laser is focused through the transparent rear surface of the disc onto the aluminized pits at a constant linear speed of 1.25 m/s (4 ft./s). An optical sensor then detects the alternating weak and strong reflections which are deinterleaved and error corrected. Small scratches and dust particles on the surface have little effect since they are out of focus.

There are over six billion digital sound signal bits which are the binary equivalent of the instantaneous voltage values of the original analog audio signal. In addition, there are bits on the disc used for functions such as speed control or error correction. The bits are laid out in a continuous helical track with 16 bits representing a single quantization of the analog waveform.

Of the 20 billion total bits, only 6 billion are dedicated to the audio signal. The remaining bits (about 14 billion) are used for: error correction, parity checking, synchronization, eight-to-fourteen modulation, and other subcodes. Essentially, there are two kinds of bits on a disc—audio bits and working bits. The working bits are never heard in the final audio.

Basically it breaks down to this: 41.8% of the bits are eight-to-fourteen modulation bits, 32.7% are audio, 17.4% for merging, 4% for synchronization, 2.7% for parity, and 1.4% for subcodes.

These are fixed ratios of the working bits to audio bits and do not change regardless of how few or how many billions of bits are encoded on the disc.

Added up, the total working bits are 67.3% of all those encoded on the disc with

# 7/CD

## CD Player

7/CD - F	Features
7/CD - F - CDD	Compact Disc Design

very little of the disc, used for the actual audio. This breakdown is shown in the table below.

**Table 1**  
**Bits Percentage**  
**Composition of a**  
**Compact Disc**

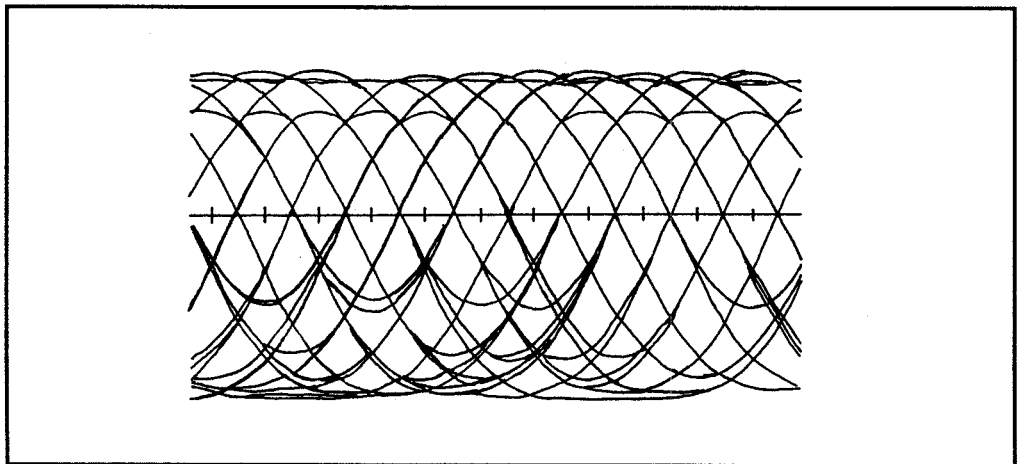
EFM	41.8%
Audio	32.7%
Merging	17.4%
Sync	4.0%
Parity	2.7%
Subcodes	1.4%

### Eye Pattern

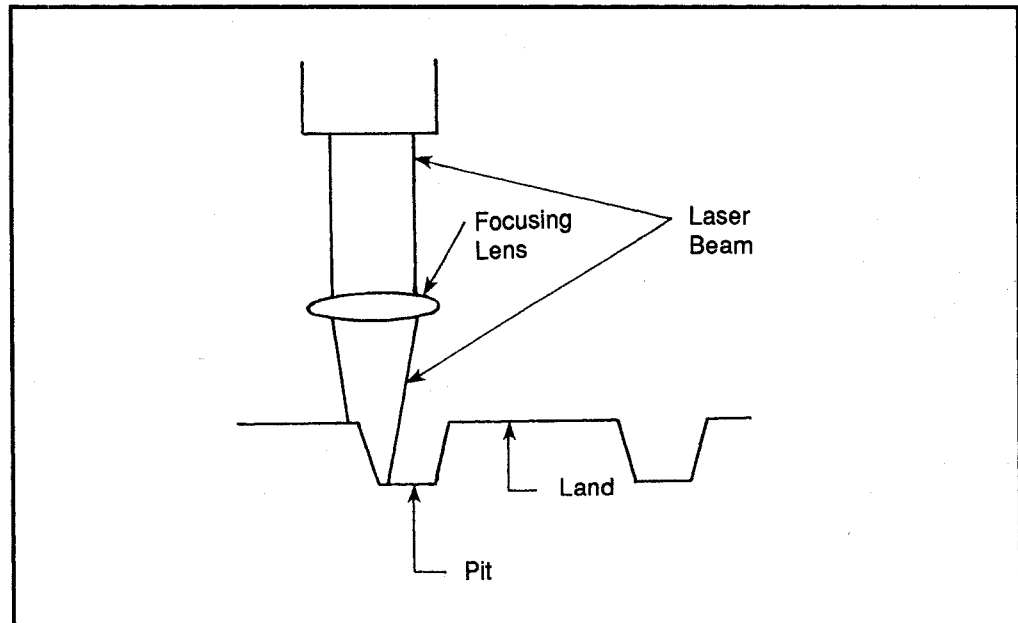
The ability of a laser pick-up to identify a transition correctly can be measured by means of an eye pattern. The eye pattern is a measure of the efficiency of a transmission channel. For example, if a disc has been stamped with pits and lands of equal size and distance (normally this is not so), when the laser scans this disc it would see transitions spaced at regular intervals along the disc.

If the output of the laser photo pick-up diode was viewed on an oscilloscope to measure the voltage, the eye pattern would look somewhat like a sine wave.

The pattern is not like that of a square wave, as might be expected from a digital system because the transition between pit and land is sloped, rather than completely vertical. An eye pattern is shown in Figure 4.



**Figure 4:** Eye pattern



**Figure 5:** Transitions from pit to land

The laser spot does not move from pit to land immediately because the pit has a small amount of measurable diameter. As the spot crosses the edge of a pit, the amount of light reflected decreases or increases gradually. The ideal eye pattern is generated by a laser which is assumed to be in perfect focus, with correctly aligned photodiodes, and with all other pertinent parameters at their optimum values. As the parameters become more negligent, the eye pattern deteriorates until it is impossible to detect the transition between the pits and the lands.

Think of the laser as a movie projector's lens and the photo diode as your eye. If the projected image is out of focus it becomes difficult to decipher what is seen by the eye. The sharpness of the image is similar to an eye pattern.

Other things like cleanliness of the lens and the quality of the image could also affect the system's quality or eye pattern. The same would happen in a CD player. If the CD were dirty or scratched, the eye pattern would decrease.

### **Eight-to-Fourteen Modulation**

In order to read the recorded information from a reasonably compact area and with few errors, it is necessary to distinguish between the pits and flats. For this the eight-to-fourteen modulation method is used.

Eight-to-fourteen modulation is merely a way to store more bits per inch and to decrease the number of errors in transition recognition. If information density

# 7/CD

## CD Player

7/CD - F

Features

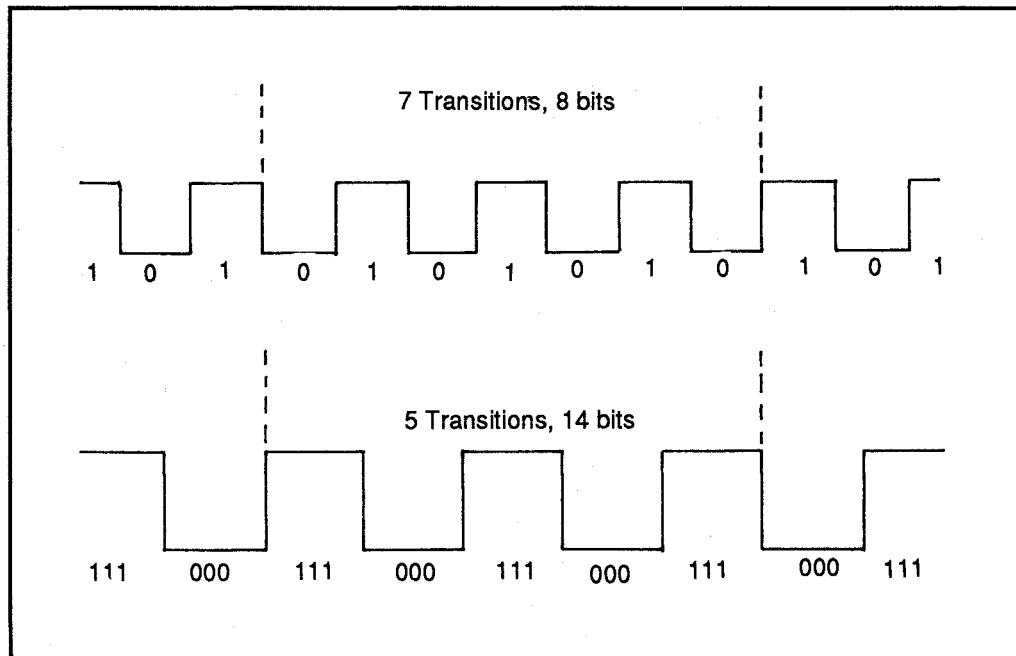
7/CD - F - CDD

Compact Disc Design

were left on a disc in the 8-bit format a more accurate pick-up system would be needed to see the pits and lands on the disk. This would increase the cost of a CD player beyond most consumer budgets.

The pick-up device, a photo diode, can be overrun with data just as the eye sees moving pictures as a continuous stream. Play a movie too fast and the eye cannot pick-up all the information sent to it; the transition between pictures is too short. Play too slow and the eye has to view the same image longer than required to process the information. The transition between pictures is too long. The same happens with a photodiode. If the data rate transition of the reflected pits and flats happens too fast, the diode doesn't have time to process the data. If it is too slow, the system becomes inefficient.

Assume that the minimum allowable distance between transitions is 1 mm. An 8-bit data stream (the data bits) then requires 8 mm for encoding on the disc surface, seven transitions between the pits and the lands with 1 mm between each, and 2 mm for the first and last bits. A 14-bit stream (the channel bits) could take the same physical space as an 8-bit stream because it would have 3 bits between each transition instead of only 1. There would be only 4 transitions required to transmit 14 bits in the same space that the 8-bit stream had used.



**Figure 6:** Comparison of seven transitions (8-bit) and 5 transitions (14-bit)





7/CD - F	Features
7/CD - F - CDD	Compact Disc Design

Fewer transitions means fewer errors because the distance between transitions can be greater and so a greater eye height is obtained.

In an 8-bit system there are only 256 ways to arrange the data, but a 14-bit system has 16,384 possible ways. When converting the 8-bit stream, we must make sure that the resulting bits have transitions that occur at least 3 bits apart, which also means that there are at least four groups of three consecutive identical bits contained in the 14-bit word. This allows the transitions from pits to lands and from lands to pits to happen less often than in an uncoded 8-bit stream.

There are 267 bits from the 16,384 possible 14-bit patterns that meet this criterion, more than enough to encode the 256 resultant combinations of 8-bit. The 14-bit to 8-bit equivalents are stored in a table in a read only memory (ROM) chip in the CD player.

### Merging Bits

Added to the 14-bit symbols are 3 merging bits to keep correct the number of transitions between the symbols. The merging bits are added to ensure that there will never be a pit shorter than the time it takes to encode three binary digits, and no longer than 11 binary digits. The last bits added to the music data are the synchronization bits, the subcode bits and the parity bits which complete the frame.

### Synchronization Bits

The synchronization bits are added to ensure that reading data begins at the start of each frame of data, and the parity bits help in error compensation. The synchronization bit is a fixed pattern of 27 unique bits that doesn't occur anywhere else in the frame. They are easily identified and help the CD player lock onto a pattern so that it can decide where each frame begins and ends.

### Subcode

The 8 subcode bits added provide information to the CD player which consists of the lead-in and lead-out signal, table of contents, control codes, music start flag, track number and time code. Only 2 of the 8 subcode bits are used for this information. The lead-in and lead-out is placed just in front of where the signal area starts on the disc and the lead-out signal appears right after the end of the signal area. The table of contents consists of the selection time, the number of selections and the total playing time of the selections. The control codes merely tell the CD player the data is either a 2-channel or 4-channel recording. (Currently only 2-channel players are being made.) The control code can also tell the CD player to use preemphasis during playback. The music start flag is placed in the blank space between selections. By counting the music start flag, the CD player can choose any selection on the disc. The track number and index on a disc consists of the music selections numbered from 1 to 99.

# 7/CD

## CD Player

7/CD - F

Features

7/CD - F - CDD

Compact Disc Design

Finally, the subcode consists of the time code which allows the CD player to count the time lapsed in minutes, seconds, and 1/75th of a second.

### Parity and Error Correction

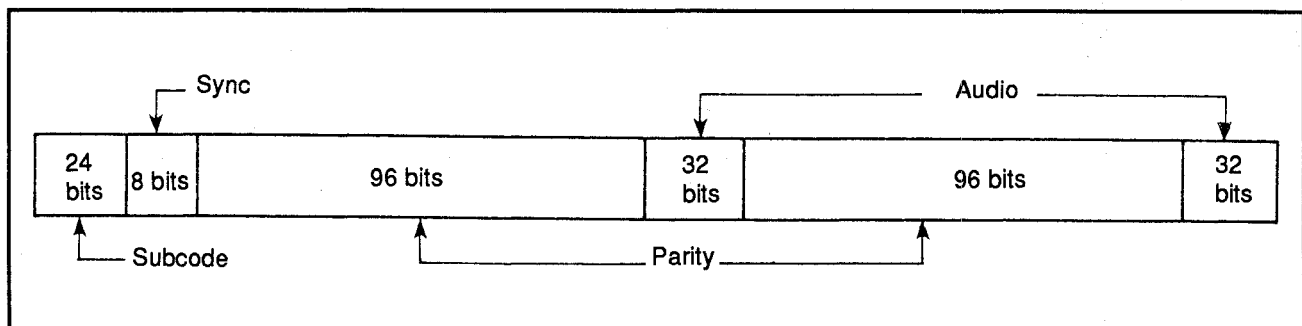
The parity bit is one of the two methods used for error correction on a CD. There are two sets of parity data added to each frame of audio. The first set is used to detect and correct any errors due to lost data that might occur. The second set is used to determine if an error occurred. Simply put, parity is a total number that must agree at beginning and end. If the data being sent is supposed to total 500, and the end total after sending is 499, the CD player knows that 1 bit has been dropped and must be replaced.

The other method of error correction is interleaving. Interleaving takes the data and shuffles it in an ordered way throughout the disc in different frames. An example of interleaving would be a series of numbers from 1 to 10. If the interleaving is set at 2 then every other number will be in succession.

The advantage of storing information in this manner is shown with a simple set of numbers of 1, 2, and 3 which total 6. If when read back, the system reads a 1 and a 3 and a total of 6, it would calculate the missing data to be a 2. So, when reading data, the CD player deinterleaves the data, checks to see if any information has been lost, and then replaces any lost data with the assumed value.

### Frame Storage

Music data is stored in frames on the CD. A frame is the smallest block of data that the CD player works with at one time. It holds 588 bits which are encoded as the channel bits. A complete frame consists of the synchronization bits, the subcode bits, the audio bits, and the parity bits. Each frame of 588 bits consists of 6 sampling periods, 24 audio symbols, 33 data symbols 17 channel bits and 27 sync bits. On a single disk there can be some 34 million frames. Figure 7 shows a breakdown of this information as it is converted from analog to digital and finally placed on a CD.



**Figure 7:** A frame consists of sync, subcode, audio, and parity in specific order



---

7/CD - F	Features
7/CD - F - CDD	Compact Disc Design

---

**A/D Converter**

All of the stored information is converted back to the music you hear through a 16-bit analog-to-digital (A/D) converter. A stereo signal requires two 16-bit sampled periods, one for each channel. Since there are four symbols (each symbol is 8 bits) per sampling period, the requirement of the A/D converter is met and creates crystal clear sound.



---

7/CD - F	Features
7/CD - F - CDD	Compact Disc Design

---

# 7/CD

## CD Player

7/CD - F

Features

7/CD - F - CDPD

CD Player Design

## 7/CD - F

### Features

## 7/CD - F - CDPD

### CD Player Design

Most consumer CD players on the market employ the front loading single disc method, though multi disc player systems are slowly replacing these. Most CD players now use a tri-laser beam pick-up with very few, if any, single-beam systems being sold. However, even a well aligned single-beam laser CD player can outperform a badly aligned tri-laser system.

#### Power Up

When powered up, the CD player will look to see if a disc is loaded. If so, it will scan the disc (and may begin to play it). Otherwise the unit will display a message like “DISC” or “Ld,” prompting you to load a disc into the unit. Some of the more expensive models may take a bit longer to be ready as they run a set of diagnostic tests on their internal components to make certain that all of the electronics are working properly.

#### Display Panel

The unit will have some kind of lighted display panel, most often made with a Liquid Crystal Display (LCD) or Light-Emitting Diode Display (LED). LED displays usually are more colorful than LCD displays, but both serve the function of relaying information to the user.

Usually the information on the display is about the disc when loaded, such as track number, elapsed time or time remaining on a track (song or selection). When a button such as Play, Reverse, or Forward is pressed, it may be displayed on the display panel.

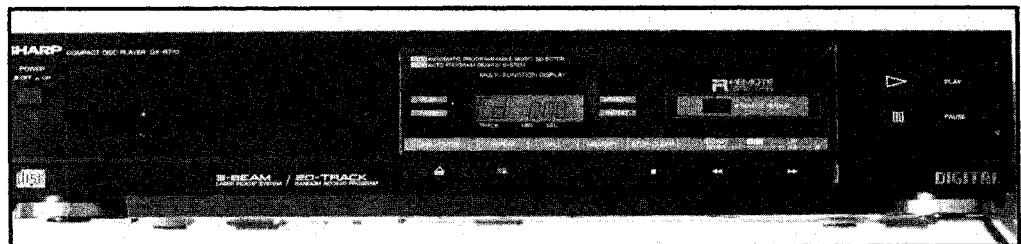


Figure 1: CD player

# 7/CD

## CD Player

7/CD - F	Features
7/CD - F - CDPD	CD Player Design

### Connectors

The rear panel of the CD player is not as dramatic as the front panel. This is where the output connectors, the power cord and a shock hazard warning for opening the cover are located.

Some players may have a separate fixed output, line output and subcode output. In general, the line output is used for hooking the unit to your stereo system or any unit with a line input. It will have an output range from 0.5 V to as high as 3.0 V.

This is more than adequate for most amplifiers. It also shows you that when connecting the CD player to the amplifier, it's best to consult the manuals for both to be sure that the output of the player is suitable for the input of the amplifier.

Some CD players will have a turn screw which will change the output voltage to vary in the line output voltage range. Changing this is only recommended when equipment and specification sheets are available for matching the CD player to an input device.

Newer players are adding the ability to view the digital stream of decoded information as outputted. This pulse code modulation (PCM) contains the same information that was decoded by the laser pick-up device. The advantage of this data is that it can be changed digitally before it is converted to an analog signal for listening.

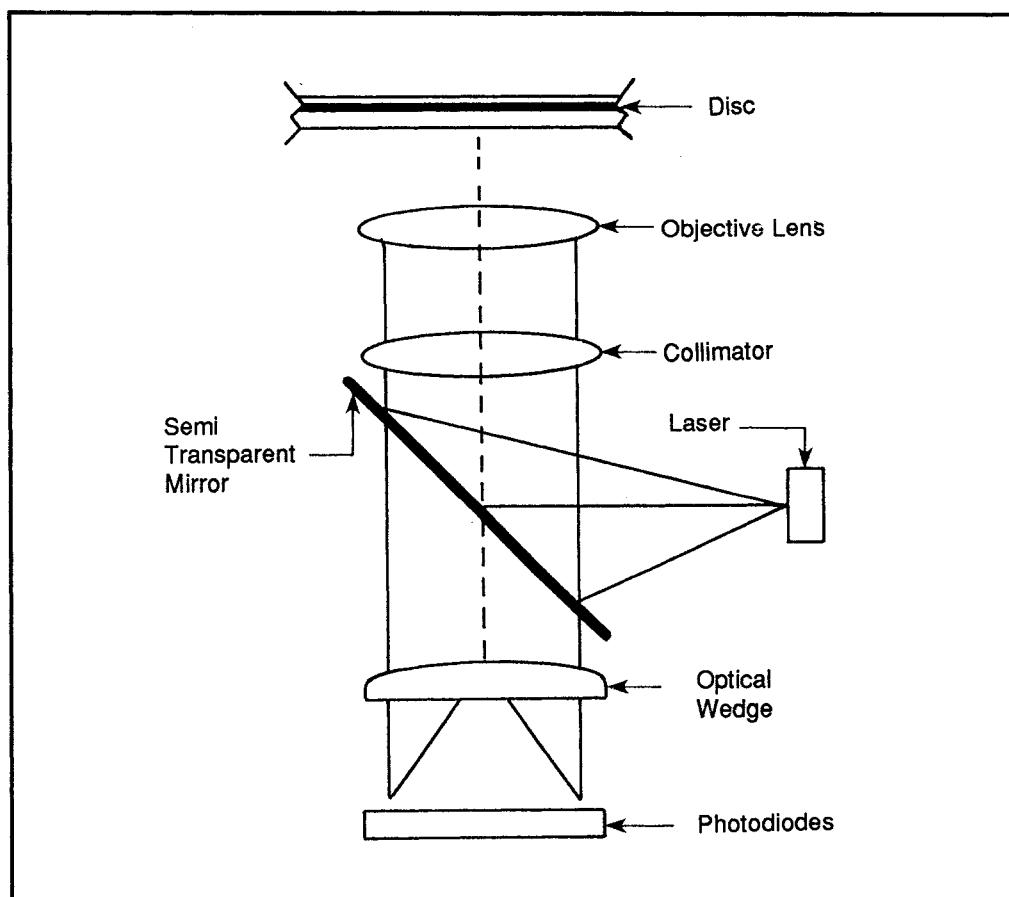
Subcode information is the section of data encoded on a CD that is relevant to the elapsed time, track number, indexes and other nonmusical information. Most consumers have no need for these final two output options, but they are available for those who desire more.

### Differences

Different compact disc players have different functions. Icons may be used in place of words for selected functions, and some functions may do more than one thing depending on how selected.

Some CD players may have a headphone jack and headphone control level built in for listening directly to the CD without an external amplifying system. In such cases, the player will have an internal amplifier.

Most CD players come with a remote control. In fact, it is becoming almost impossible to buy a piece of electronic entertainment equipment today that doesn't have some kind of remote system.



**Figure 2:** Single laser optical pick-up system

Many CD players don't allow you access to all the functions available without a remote.

Next we look at what can be found in a CD player. Short of having a degree in electronics and opening up a CD player to see what it can really do, there are a few things to consider. Among these are: multi laser versus single-laser; degree of oversampling; filtering; D to A converters; error correction; and player construction.

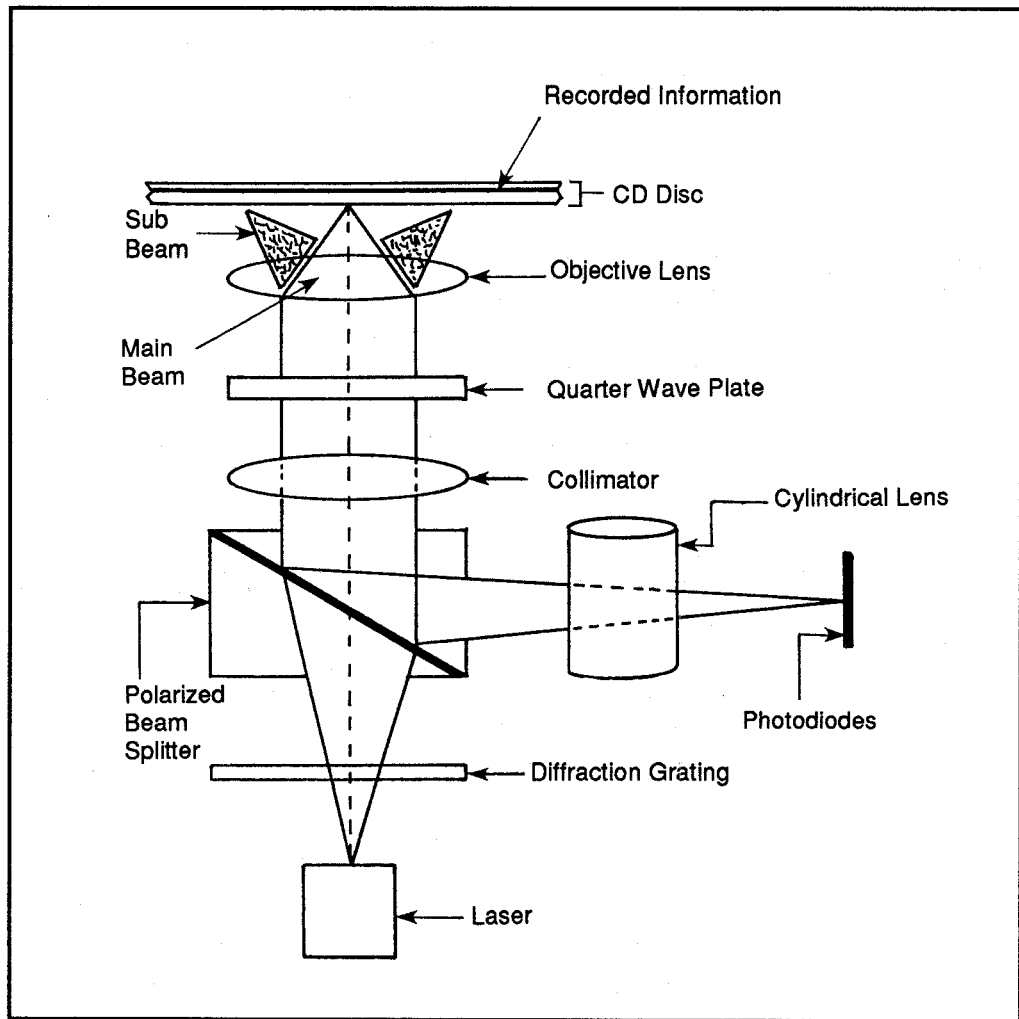
### The Laser Beam

Two types of tracking systems have emerged in CD technology—single laser and multi-spot laser. A single spot laser is used to read the information from a disc and provide control signals to maintain tracking and focusing. If the beam deviates from the center of the track, the amount of reflected light will change. This change is registered and used to change the alignment of the optical tracking

device. Also, if the unit is out of focus the player can detect this and adjust the beam to compensate.

A multi-spot takes a single laser and splits it into three different beams via a prism. The center beam is used to read the information (pits and lands) while the other two beams scan in front of and behind the main beam providing focus and tracking information.

With these beams ahead and behind the main beam, any misalignment can be detected faster than in a single beam unit and can be adjusted more quickly to small changes, thereby tracking more effectively.



**Figure 3:** 3-beam laser optical pickup system



# 7/CD

## CD Player

7/CD - F	Features
7/CD - F - CDPD	CD Player Design

Both can still be purchased, though most manufacturers since the early part of 1990 have been using only multi-beam pick-up devices.

A big bold “3 Lasers” used to be printed on the unit, but now it is just assumed to be a tri-laser pick-up system.

### Sampling and Oversampling

Sampling is the road from analog to digital. Sampling takes discrete samples of an analog signal at regular predetermined intervals. Oversampling can be single, double or quadruple. Many believe that 2 x oversampling is sampled twice and 4 x oversampling is sampled four times. This is not true. Oversampling involves only the ratio of the frequency used to sample the signal. 2 x oversampling uses twice the frequency; 4 x oversampling uses four times the frequency.

The average person can hear frequencies up to about 20 kHz. To take enough samples to reproduce one second of sound requires some 40,000 samples (40 kHz), or twice the maximum range of hearing. This is known as the Nyquist Sampling Theorem which states that by sampling at this frequency, the original frequency band can be reproduced completely and accurately.

### Aliasing

The maximum bandwidth a CD player can theoretically achieve is 22.05 kHz. Anything above that is cut off due to aliasing. Aliasing is the phenomenon whereby frequencies above half the Nyquist frequency will fold down across that point and interact with the components in the audio band. One might think sounds about 20 kHz would be cut off and not captured by a digital machine. Unfortunately, the upper frequencies are not cut out, but tend to distort the lower-frequencies.

An example of aliasing happens from overtones produced by a musical instrument. A musical instrument which produces a 10 kHz note will have overtones of 20 kHz, 30 kHz, 40 kHz, and so on.

One way to correct aliasing problems in the digital signal is to sample at a high enough frequency to encompass these higher overtones so that the higher harmonics do not cause significant amounts of distortion. A system with normal sampling samples at 44.1 kHz (a little over twice the human range of hearing), double at 88.2 kHz and quadruple at 176.4 kHz. The advantage is that the noise power is distributed over a bandwidth that is four times as wide.

Usually by increasing the oversampling you increase the S/N ratios. The S/N ratio for machines with oversampling increases anywhere from 90 decibels (dB) to over 105 dB, compared to a machine without oversampling, which may have a S/N ratio of 85 to 95 dB.

# 7/CD

## CD Player

7/CD - F	Features
7/CD - F - CDPD	CD Player Design

In theory, a higher sampling unit should be better than a lower one, but this is all dependent upon the sampling scheme used. One manufacturer with a 44.1 kHz clock (normal sampling rate) could out perform another with a 176.4 kHz clock (4 x oversampling), depending on the design of the system.

### Filtering

Filtering for a CD player can be either analog or digital. Either way the signal is filtered, it is an analog signal by the time it gets to the speakers. So why have a digital filter at all?

Using analog filtering alone is not enough. Oversampling and digital filtering are basically the same. Both decrease the noise level in a signal. The noise level is called the noise floor, and oversampling decreases the amplitude of harmonics above the 22.05 kHz bandwidth of a CD player.

An analog filter with a gentle roll-off will clean up harmonics of higher frequencies without introducing phase shift into the audio frequencies. If digital filtering is not used (nor any oversampling), an analog filter must be used. The reason is that a signal without some filtering will have the ultrasonic frequencies (those above 22.05 kHz) introduced into the audio signal.

By digitally filtering those frequencies, such as in a double oversampling technique, we push the ultrasonic frequencies (starting at 24.1 kHz) to 68.2 kHz. Now that the noise no longer begins so close to the human hearing limit of 20 kHz, a low-pass filter with a more gentle roll off may be used to reduce noise.

Existing analog filters are quite effective in removing noise but by themselves have a very limited performance. By combining a digital filter with an analog filter, both in just the right way, the limitations of analog filters can be overcome. Combining a digital filter with an analog filter may mean using oversampling (2 x, 4 x, or 8 x) and an analog filter with a gentle roll-off.

### D/A Converters

CD players may have one or two digital-to-analog (D/A) converters. In the latter case, one is dedicated to each channel.

Data comes off the CD in a single stream. The data is demultiplexed into both the left and right channels, and then into stereo sound. A single D/A converter can do this job alone usually at a rate of 88.2 kHz, which is the combined rate of both channels. But a single D/A converter must process both channels independently, left then right, or right then left, and then send the signals out. This will cause one channel to be slightly behind the other channel. A CD player with quadruple oversampling would have to do this at four times the normal rate of 88.2 kHz or at 352.8 kHz (352,800 conversions per second).

# 7/CD

## CD Player

7/CD - F	Features
7/CD - F - CDPD	CD Player Design

Single D/A converters at this speed cost considerably more than two slower D/A converters, one for each channel. The use of two D/A converters eliminates the time lag or phase shift between channels.

A system may use either a 14-bit or a 16-bit D/A converter. A 14-bit converter can mimic a 16-bit converter, but it is less accurate. A 16-bit converter can achieve higher levels of music clarity while also increasing the S/N ratio. Any 16-bit digitally filtered disc player will have the highest possible S/N ratio. In addition, the dynamic range of a 16-bit unit is greater than that of a 14-bit unit.

Newer units on the market claim to be using 1-bit and 2-bit technology or 18-bit D/A converters. What they're really doing is using digital filtering and noise subtraction techniques on full 16-bit samples to produce these additional bits of accuracy.

### Vibration

A good CD player will have feet designed to provide the best music playback possible. This may seem irrelevant at first, but consider what happens to a record player when bumped. A CD player can be affected by the same type of problems. The most common of these is skipping. This sounds like missed music as opposed to skipping on a record player where there is an actual scratching sound as the stylus hops over the grooves.

To reduce the effects of vibrations, the CD player needs large-sized feet made of rubber or some other synthetic product capable of absorbing the vibrations. The feet must also be able to support the weight of the player without being compressed to the point that vibrations aren't absorbed. The feet of CD players are chosen carefully and treated with anti-aging and antioxidant compounds.

Any unit will skip if sufficiently disturbed, but a unit properly manufactured should be able to withstand a large degree of vibration.



---

7/CD - F

Features

---

7/CD - F - CDPD

CD Player Design

---

## 7/CD - M

### Maintenance

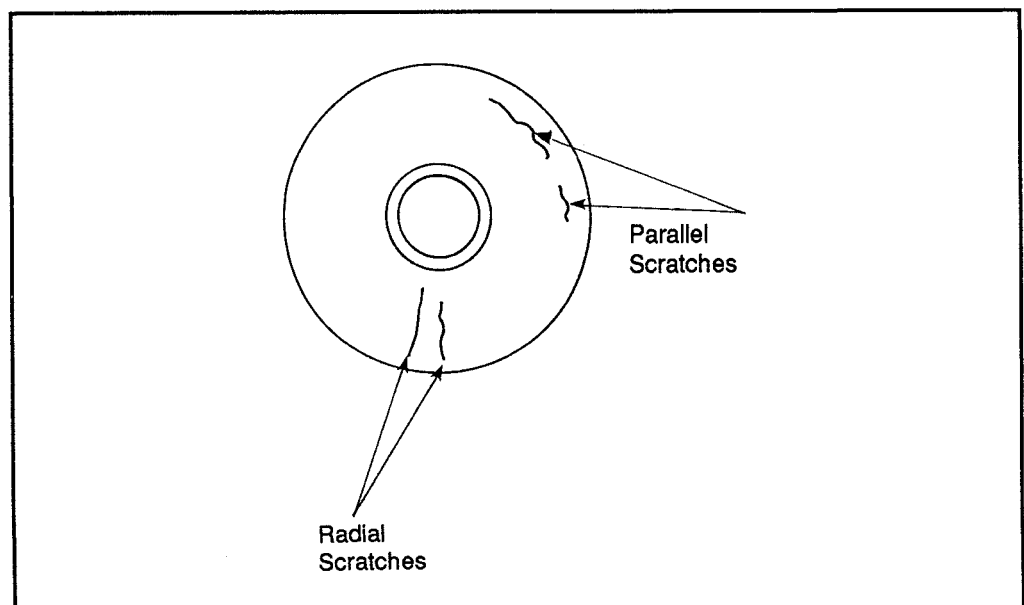
#### Caring for the Compact Disc

When compact discs hit the market, advertisers were quick to state that CDs were indestructible—that dust, dirt, fingerprints, scratches and cigarette smoke would have no effect on playback. One advertiser even claimed that spreading peanut butter on a disc couldn't stop it from playing. (Smearing peanut butter on the label side would probably have no effect, other than to make a mess of the player, but anything opaque or even semi-opaque on the clear side will dramatically affect the playback.)

While some disc players can play a disc that has scratches, fingerprints or contaminants on it, the disc should always be handled with care and kept clean.

#### Scratch Effects on a Disc

The effect of an occasional scratch depends on how the scratch is aligned on the disc. A scratch across the disc may only cause a few bits of each frame to be lost, whereas a scratch running parallel to the tracks could completely wipe out a series of bits beyond the capacity of the CD player's error correction. Fingerprints and other deposits may or may not have any effect on a disc. This depends upon the chemical composition and thickness of the deposit.



**Figure 1:** Scratches across and parallel to tracks on a CD's optical side

# 7/CD

## CD Player

7/CD - M

Maintenance

The disc should always be grasped by the edges. Some disc player loading mechanisms won't allow for this (like an in dash automobile CD player). You will inevitably have to grasp the disc in a manner that may deposit skin oil and perspiration from fingerprints onto the surface. Even so, this kind of handling should be minimal.

### Dust

Dust can slowly build up on the disc and cause intermittent skipping. Dust on the CD player can also begin to cause problems as it may slowly find its way into the player, usually through the disc drawer when loading or unloading a disc.

### Good Location

Placing the CD player away from the elements is a wise decision. A home CD player should always be in a good location. Many players have black finishes and will absorb heat from the sun. This causes the player to heat up well above room temperature.

Increased heat can age or even damage the internal electronic components by overheating them. Also the increased heat can cause internal rubber and plastic parts like the disc tray, gears or even the laser pick-up system to warp. If a disc happened to be in the unit, it too could become warped and unusable.

CDs can withstand a fair amount of temperature changes, but warping can occur well below its softening temperature of 200° to 230° F. Obviously, leaving a CD or player near a fireplace or on the dash of a car can produce temperatures hot enough to warp it. Extreme cold can also damage a disc, causing it to either crack or cloud. Taking a disc from one temperature extreme to another can be hazardous to your disc's life. In general, a temperature that feels good to you is probably good for your disc as well.

## Cleaning the Compact Disk

If a CD becomes dirty and seems to be causing problems during playback, a good cleaning may be in order. (This is the first step when troubleshooting a player that is skipping.)

### Compressed Air

The simplest way to clean loose dust from the surface of a disc is to use a can of compressed air. Blowing on the surface of a disc is not recommended. You may put more contaminants on the surface than you are trying to remove.

### Cleaning Fluid

Further cleaning can be done by hand, or with a commercial cleaning unit. If cleaning by hand, use a clean, lint-free, soft cloth. The cleaning fluid should be specifically for CDs. Denatured alcohol may also be used. Either way, clean **ONLY** on the clear side of the disc. The reason is that some labels are alcohol-

based and if they come in contact with alcohol-based cleaners can be dissolved or smeared. Cleaning the label side doesn't improve disc performance anyway, (since the playable side is the clear side), but may be aesthetically appealing.

Never use a dry cloth alone when cleaning a disc as this may leave scratches in the disc. Also, never use cleaners such as benzene, or solvents such as paint thinners. These can cloud or soften the plastic as well as remove the label. They may also dissolve the lacquer coating, and in extreme cases may even remove the layer of reflective aluminum beneath.

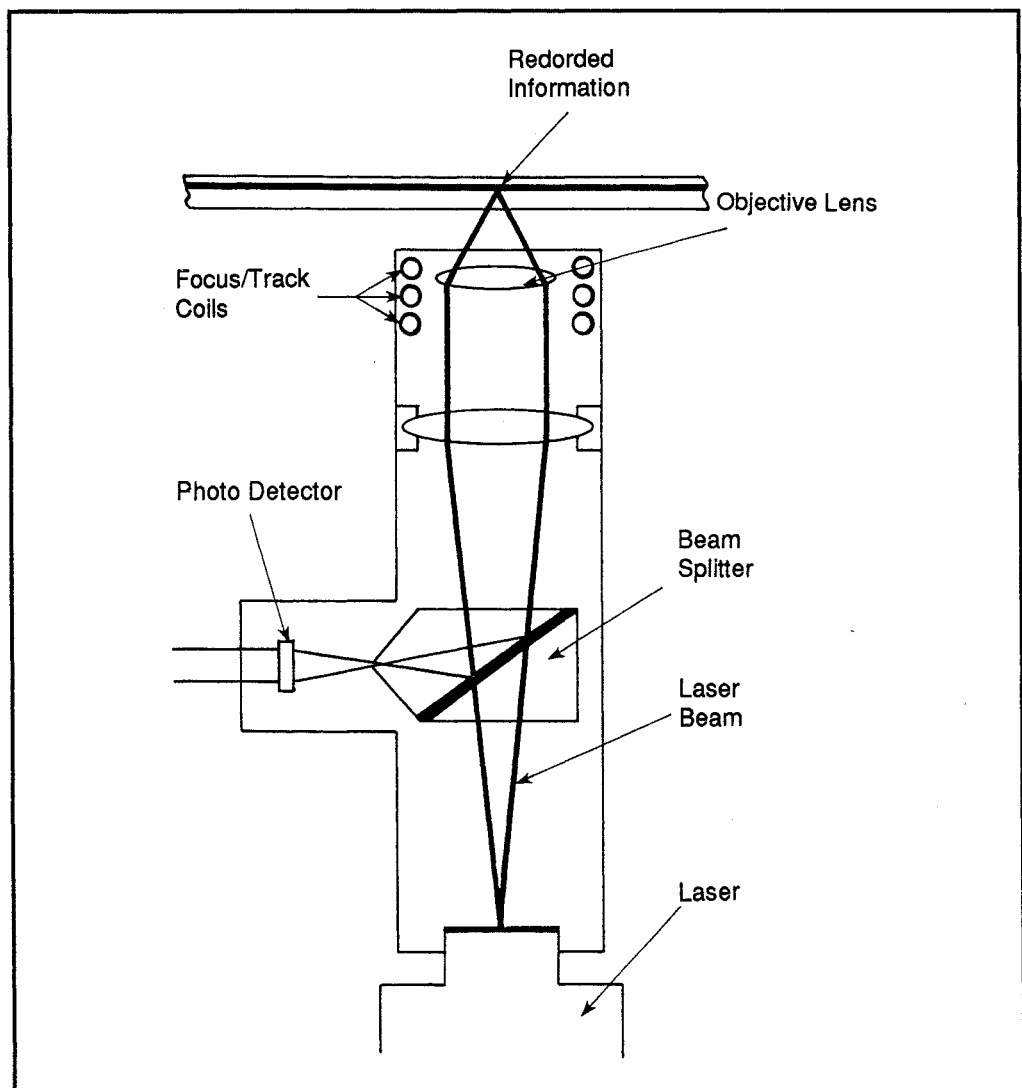


Figure 2: Laser lens assembly

# 7/CD

## CD Player

7/CD - M

Maintenance

Always clean in straight lines from the center of the disc outward. Never wipe in circles, or by following a circular pattern around the surface.

**Cleaning Machines** Commercial CD cleaning machines usually use a compact disc radial cleaning system which occupies barely more horizontal space than a compact disc. The system rotates the disc while cleaning it with a chamois pad. The unit can be either battery-operated or hand-turned.

When purchasing a mechanical CD cleaner, you should try to avoid those units which clean the disc by wiping it along its radius. Likewise, don't buy cleaners that are detergent based, as they will leave residues which can cloud a disc.

### Cleaning the Player

#### Outside

A good practice is to occasionally clean the outside of the disc player whether it is a portable or home unit. Merely dusting the outside of the unit is not enough. When cleaning the outside and using a cleaning fluid, be sure that it is safe. If you are uncertain, experiment on an inconspicuous portion of the CD player to see if it will be marred or discolored.

#### Inside

Inside cleaning consists of cleaning the disc tray and laser optics, and possibly dusting the circuit board and removing foreign objects. Blow out any dust



Figure 3: Disc cleaning unit



**7/CD**  
CD Player

7/CD - M

Maintenance

particles from the inside before cleaning the disc tray and laser optics. This is best accomplished with the unit open and away from other items that the dust may settle on.

It is possible that something has managed to get inside the CD player causing it to function improperly. It could be as simple as an insect sitting on the pick-up optics, or as serious as something conductive that has caused a short which led to more major component damage.

Checking (or cleaning) the inside requires opening the case. This will most likely void any warranty you have. Consult your manual before doing so.

Before beginning, remove the unit from its current location and place it on a static-free cloth or surfaced table. Inspect the unit to determine which screws hold the casing on the player. Carefully remove these and lift the cover away.

Once inside, look for any items that may have fallen into the CD player. If found, remove them, reassemble the unit and try again. If nothing is found, visually examine the interior for any obvious signs of damage such as broken wires, loose connectors, burned components, etc.

Next, look at the optical pick-up unit, if it can be seen, and check to see if the lens appears to be free of contaminants.

**Laser Lens  
Cleaning**

Remember that you are dealing with a laser pick-up device and that laser light can be harmful to the naked eye. However, lasers used in most home CD players are at a very low level, classified as class 1 lasers, and shouldn't cause eye damage. Prolonged exposure could be harmful, though. Always clean laser optics with the unit unplugged.

Nothing in the optical pick-up can be serviced, so if a problem is eventually discovered here, the unit must be replaced as a whole. Before you do this, try cleaning the pick-up and the related parts.

If the lens in the CD player is dirty it can be cleaned using lens tissue made for that purpose. Lens tissues are available from most camera stores along with proper cleansers for optical cleaning. A special camel's hair brush can be used for cleaning dust deposits off a lens. Do not use standard brushes or tissues, as these may scratch the optics. Canned air may be used for removing loose dust particles.

Check to be sure that the optical pick-up is moving properly over the travel bars.

**7/CD**  
CD Player

7/CD - M

Maintenance

Cigarette smoke and dust can cause optics to transverse the travel rods or slide rods and stick in places in CD players using this design. This will sometimes cause disc players to produce dropouts or skipping during playback. Clean these slide rods and afterward apply a slight dab of nonconductive, non petroleum lubrication. (Swing arm pick-up units generally require no lubrication.)

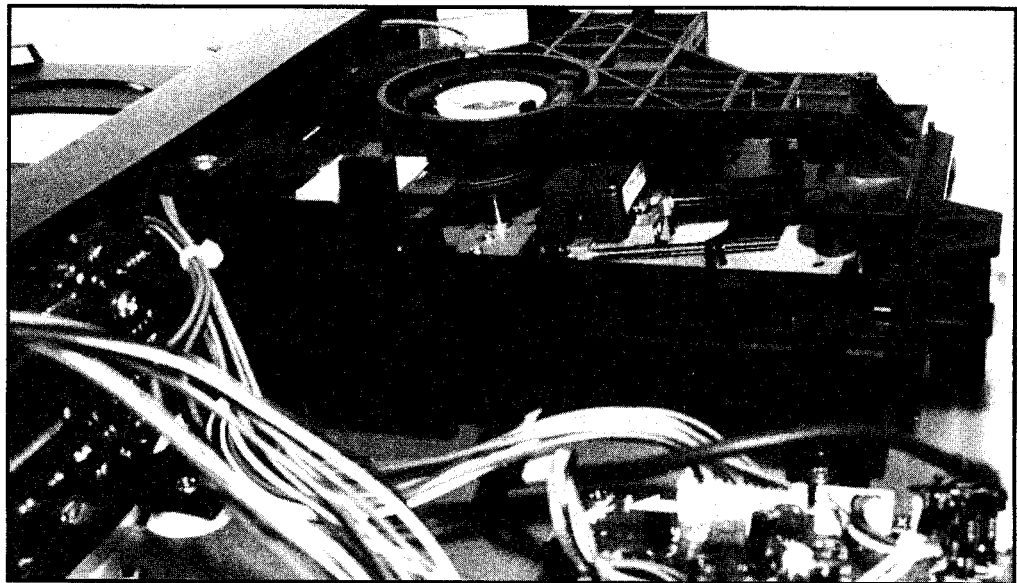
**Disc Tray Cleaning** The disc tray requires wiping with a damp cloth. The tray should not require more than this unless some foreign material is stuck to the tray.

**PC Board Cleaning** Dust, dirt and nicotine from cigarette smoke can accumulate on the interior PC board surfaces. Normally this causes no trouble, but it's possible for the buildup to be severe enough to become conductive.

Use a soft brush or a can of compressed air to remove loose contaminants from the surface of PC boards. When blowing the unit out, try to place it in such a position so that the debris fall out of and not deeper into the unit.

Use a cleaner degreaser designed for electronic components to get those tough, built up spots. Do not use any household cleaners or oil-less lubricants such as WD-40. These may cause the unit to fail completely. Also, any cleaner that leaves a residue will be unsuitable for cleaning the inside of your CD player.

Electrical contacts and connectors may, on occasion, need to be cleaned as well.



**Figure 4:** Disc tray assembly



Other contaminants, such as cigarette smoke may also accumulate on the contacts.

**Remote Control  
Cleaning**

Cleaning a remote control is simple. Use a slightly damp cloth on the outside of the control to remove any buildup of dirt. Be careful around the lens. It is usually plastic and easily scratched.

The battery compartment can be a source of major problems in remote control failure. If the contacts in a remote control compartment become corroded from battery leakage, remote performance can drop or cease. Clean most of the battery acid from the compartment with a damp cloth, or use a mixture of baking soda dissolved in water on the cloth to neutralize large deposits of acid. If need be, use an electronic cleaner/degreaser or denatured alcohol to remove deposits.

Carefully clean all debris from the compartment before inserting new batteries.

**Lubricating**

It is wise to lubricate any moving parts after any cleaning or degreasing spray has been used inside the CD player, and at periodic maintenance. Most of the parts requiring lubrication can be found in the pick-up assembly and the disc-loading mechanism. The lubricant should be nonconductive and should not have a petroleum base. Use as little as possible and never use a spray lubricant.

After applying it, spread the lubricant by moving or sliding the part back and forth a few times. If the part won't move easily, plug the unit in, power it up, and press the Open/Close button a few times.

**7/CD**  
CD Player

---

7/CD - M

---

Maintenance

---

---

**7/CD****CD Player**

7/CD - TE

Test Equipment

## 7/CD - TE

### Test Equipment

**Service Equipment Needed** To service a compact disc player, you need:

- DC voltmeter
- Dual-trace oscilloscope with a bandwidth of about 60 MHz DC
- Frequency counter with a range of 250 MHz and a sensitivity of 20 mV
- AC leakage tester
- Audio tester (line level)

Some CD player manufacturers supply special tools for servicing their units, others do not.

Keep in mind that there are few adjustments or calibrations you can do inside the CD player—and fewer yet if you don't have the service manual for that specific unit.

One or more test discs are needed for checking frequency response, dropout, and alignment of the optical unit. These test discs may be available from the manufacturer. You can make your own error correction test discs as shown below.

**Making a Test Disc** Purchase a roll of black-matte tape that is 1/32" wide. (This can be found in art stores.) Place a single strip running on the bottom of the disc from the inside edge to the outer edge.

Make sure that the tape adheres securely to the disc and is trimmed at the edge. Now play the disc in a unit you know is working. You shouldn't hear any skipping. If you do, the player has some severe problems.

Add a second strip across from the first. Play the disc again. Add additional strips one at a time halfway between the others. You should be able to do this for a total of six to eight strips before errors are heard. (Note: This is a great device to try at the store when purchasing a CD player.)

Checking CD players annually with a disc striped like this can be used to determine if optics or laser transport rails are becoming dirty.

**7/CD**  
CD Player

7/CD - TE

Test Equipment

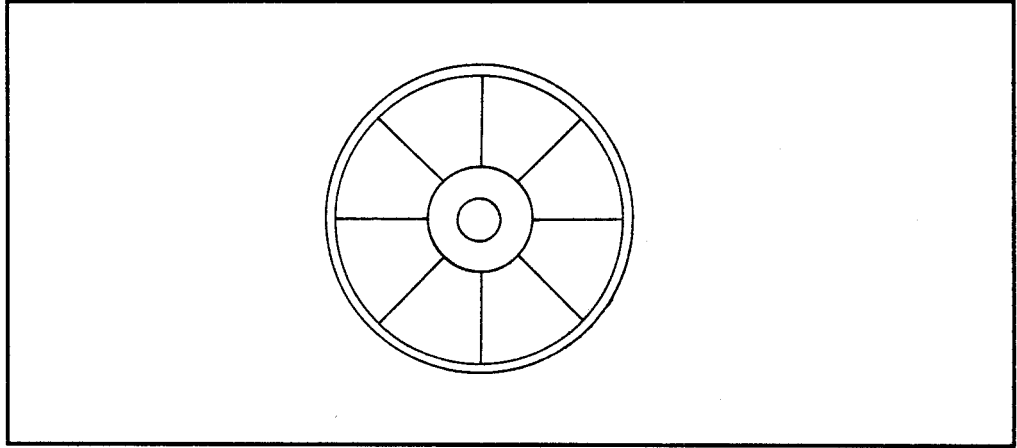


Figure 1: Error correction test disc layout

## **7/CD - TR**

### **Troubleshooting and Repair**

---

## **7/CD - TR - A**

### **An Introduction**

---

When a CD player begins to malfunction, there is little an untrained person can do—and little enough for even the experienced professional without the service manual for that specific make and model. Short of the cleaning and maintenance tips mentioned in Section “7/CD - M”, all of the internal components are unserviceable without correct training, equipment and information. Most internal components today use surface-mounted technology, which makes replacing individual components nearly impossible. Usually complete sections and even entire circuit boards are replaced rather than trying to troubleshoot to the component level. However, before giving up there are a few things you can check.

As always, begin with the obvious:

#### **Checklist**

- Is the unit plugged in?
- Has the power switch been pressed?
- Do you know how to work the various controls?
- Is a CD in the drawer?
- Is the CD player properly connected to the stereo system, and is this system functioning and connected properly to the speakers?

If all the above have been checked, consider testing the cables (for continuity) that connect all the parts of the system. The problem could be as simple as a bad audio cable hooked to the CD player.

The problem could be caused by a photodiode that is damaged, or the laser diode might have burned out. This would be the first probable cause of an internal malfunction. The laser assembly must be replaced as a whole.

Perhaps the digital or analog sections of the player were hit by static electricity or just simply quit. Maybe the disc isn't spinning inside the player, or the disc drawer is jammed.

## Components

In the “Troubleshooting and Repair” articles, standard conventions are used to label the various components. The parts are labelled in a generic fashion. The parts list below will serve for reference. Bear in mind that the numbering used is for convenience. These numbers differ considerably from player to player.

Part Number	Device
IC101	Pickup-servo
IC102	Servo driver
IC181	NOR gate
IC201	Motor driver
IC301	CPU (main microprocessor)
IC401	Signal processor and master clock
IC402	Controller
IC403	D/A converter
IC601	Focus controller
IC604	Laser controller



**7/CD**  
CD Player

7/CD - TR

Troubleshooting and Repair

7/CD - TR - CC

Connections/Cables

---

**7/CD - TR**  
**Troubleshooting and Repair**

---

**7/CD - TR - CC**  
**Connections/Cables**

---

First, start by checking the output cables' connections. Most disc players only have two outputs—to the left and right channels. Testing the cables and connectors is not time consuming or difficult. Check to see that the left channel output cable goes to the left channel input of the receiver or amplifier and the same for the right. If the unit has digital outputs be sure they are not being used as audio outputs.

If these connections are correct, check to see if the amplifier is switched so that the CD player is the source. Most amplifiers have a selector switch or button for selecting the input device. Also, make sure it is the CD player that is not functioning properly. Does the amplifier work when switched to other settings? If so, does the hookup of a different unit to the input which is used for the CD player work properly?

Perhaps all is working, the amplifier, the source input, but not the CD player. Check the audio cables from the CD player. The simplest way to test the cables is to try different cables you know are good. Another easy method is to use a VOM to test them for continuity.

Set the meter to an "Ohms" setting, or to the "Continuity" selection, if it has one. Touch the outer metal shield of one end of a cable with a probe. Touch the other probe to the center pole of the cable. The reading should be infinite resistance. If you get a reading (or an audible sound if your DMM is so equipped), the cable is shorted.

Next, test from the center pin on one end of the cable to the center pin on the other; and then from the outer ground on one end to the outer ground on the other. In both cases the resistance should be almost zero. A high resistance means that the connector or wire has a break. Try wiggling the cable while performing the tests above. This may reveal intermittent shorts or breaks. If all the cables check out OK, reconnect them and see if the problem persists. If so, you may have a deeper problem.

**7/CD**  
CD Player

---

7/CD - TR

Troubleshooting and Repair

---

7/CD - TR - CC

Connections/Cables

---

# 7/CD

## CD Player

7/CD - TR

Troubleshooting and Repair

7/CD - TR - DD

Disc Drawer

## 7/CD - TR

### Troubleshooting and Repair

## 7/CD - TR - DD

### Disc Drawer

#### Improperly Loaded Disc

If the problem is definitely in the CD player and not in the cables or stereo system, one possible cause is that the CD may be sitting incorrectly inside the disc tray, thereby not allowing any playback. The disc must be inserted with the label up, with the disc flat, and centered in the tray.

Usually if the disc is not placed properly on the drawer it will eject the tray until it is properly loaded. Other times an error message will be given. Especially on older players, or the least expensive ones, the indication will simply be that the disc doesn't play.

The disc drawer may become jammed from an improperly loaded disc. If this happens, carefully pull the drawer out by hand and replace the disc. (Usually the disc drawer will sense improper load and will not jam.)

It could be that the tray may have closed properly but the disc is not being grasped by the spindle. An easy check for this is pressing Play on the front panel. If the counter is advancing one can assume that there is no problem with the loading mechanism.

#### Loading Mechanisms

Inspect the loading mechanisms to see if they are working properly. With the cover off, insert a disc and load it. The disc should load, spin for a moment, and may then stop. Check for any broken gears (teeth on the gears may be missing causing a dead spot in the movement). Make sure the gear assembly is lubricated enough to allow free movement of the assembly.

#### Checklist

If the tray will not open, and there is no evidence of a foreign object in the way, check to see if IC301, the system processor, is getting signals from the Open/Close button S318. If not, S318 or the wiring between the switch and IC301 may be faulty.

See if the loading motor is receiving a signal from pin 12 of IC102 when the

# 7/CD

## CD Player

7/CD - TR	Troubleshooting and Repair
7/CD - TR - DD	Disc Drawer

button is pressed. If it is, suspect that the motor is bad. If not, there may be a problem between the motor and IC301 and IC102.

Check to see if a signal is present at pins 10 and 11 on IC102 each time the Open/Close button is pressed. The signals should invert between pins 10 and 11, high/low, low/high. Is there a correct inverted signal at pin 33 (open) and pin 34 (close) of IC301? If the signal does not invert suspect that IC301 is bad.

If the tray opens part way only, check the point where S02(LIDO) moves, as shown by a low to high change at pin 48 of IC301. Adjust S02 if necessary. If the tray opens and the motor does not stop, adjust S02.

If the tray closes part of the way only, check the point where the chuck (CHU) switch, S03, moves as indicated by a high to low change at pin 47 of IC301. Adjust S03 if necessary.

If the tray closes and the chuck drops, but the loading motor does not stop, readjust S03. Check the high to low change at pin 47 in IC301 which should be present when the disc is fully loaded.

Any problems that persist might indicate a bad IC301.

## 7/CD - TR

### Troubleshooting and Repair

## 7/CD - TR - DM

### Disc Motor

#### Hall Gain Balance

Figure 1 shows the disc motor adjustment. Connect one channel of the scope to DMCA and the other to DCMB. This allows simultaneous viewing of the A and B coils of the disc motor. Load a disc and press Play. Adjust the motor gain so the output levels at DMCA and DCMB are equal. The reading should be about 2 V peak-to-peak.

#### Sample and Hold Offset Adjustment

The adjustment for the sample and hold offset is shown in Figure 2, but it may not be available on all players. Do not confuse this circuit with the sample and hold circuit. This section is part of the pick-up servo, IC101, and controls the tracking error or TER signals.

For this test you need a test disc, as described in Section "7/CD - TE." Try several tests, each with a different number of stripes. Listen to the disc, as it plays. You should hear a ticking in the audio. Adjust the sample and hold adjustment for the minimum noise.

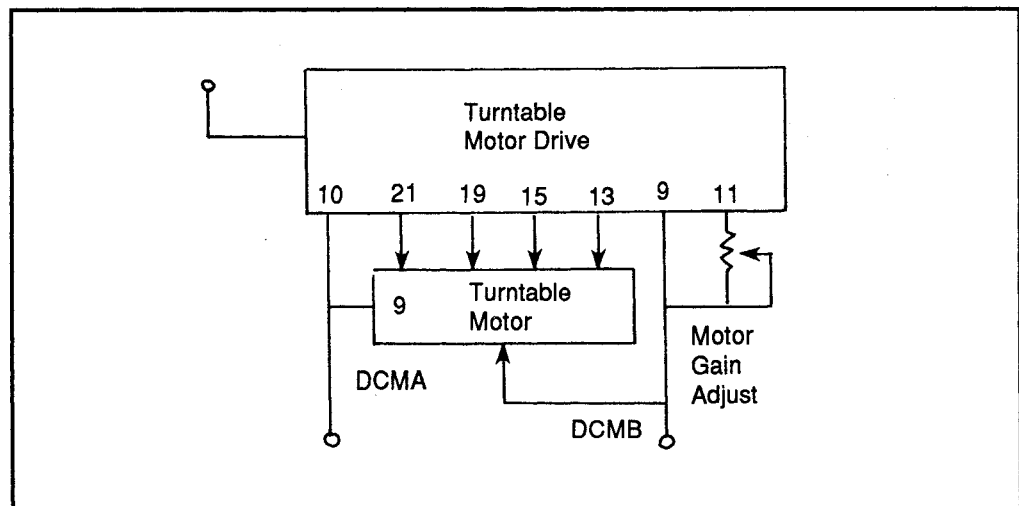
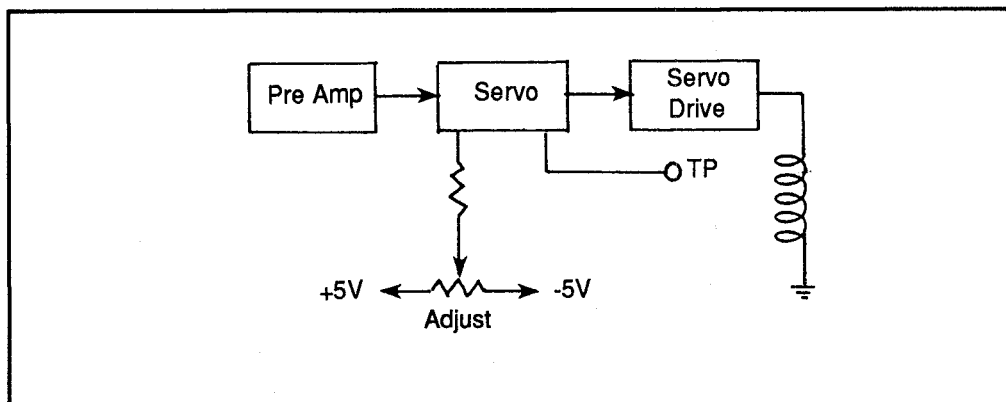


Figure 1: Disc motor adjustment



**Figure 2:** Sample and hold offset adjustment

A more accurate way is to connect the scope to TP13 of the preamp and look for the amount of audio dropout. You should be able to eliminate most or all of the dropout effect unless the pick-up servo is defective.

### Disc Motor Revolves Incorrectly

Figure 3 shows a typical motor control circuit. This circuit is designed to keep the pick-up beam moving across the disc at a constant rate. The disc motor has a fine control signal administered to it called the radial tracking error or RT signal. The RT signal is applied through a low-pass filter, an analog switch, amplifier, and drive transistors and to the pick-up motor. The RT is only passed when a tracking switch (TSW) signal is sent from the microprocessor. A NOR gate inverts the TSW signal and applies it to mixing transistors which combine the TSW signal with the tracking error (TER) signal.

During a search operation the pick-up has to move at a faster rate than during normal play. This is done by the SLF and SLR pulses sent by the microprocessor. The SLF signal is applied through the SLF transistor to the motor driver, IC201. The SLR pulse is sent through the SLR transistor to the motor driver. Both the SLF and SLR pulses cause an increase in current in the drive transistors, which then increase the motor pick-up speed. The direction of the motor depends upon the polarity of the voltage that reaches the drive motor.

If the disc is not spinning, a total failure of the drive motor could be the problem. If this is the case, check for DMCA and DMCB drive signals to the motor windings.

It is more difficult to determine what is wrong when the disc does rotate. The disc rotates at a constantly changing speed, so you must rely on waveform measurements and adjustments to correct it. The first step to correcting a motor circuit is to perform the adjustments.

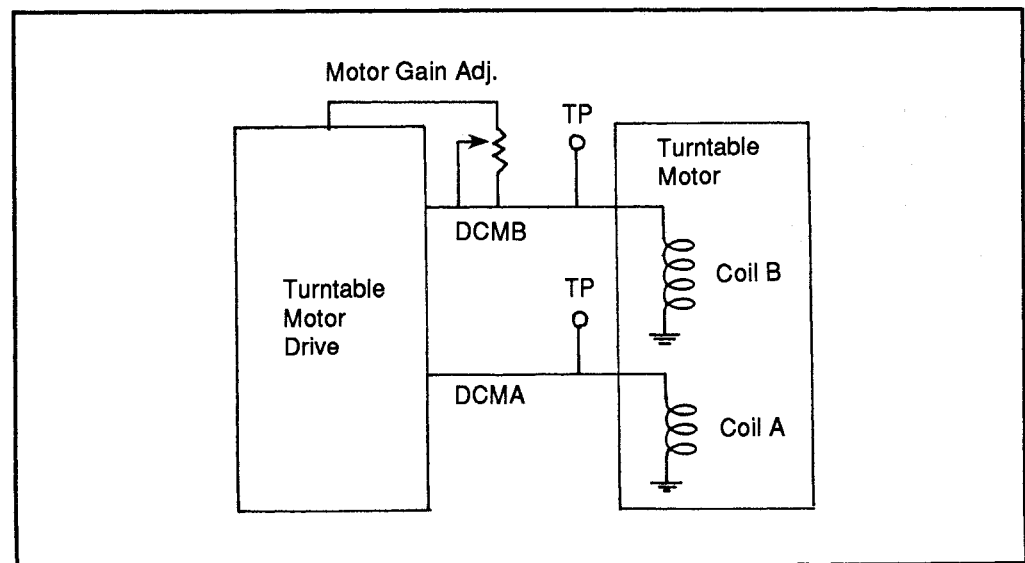
Before you dig into the disc motor thinking you've found the problem, consider the following: If the proper signals are not coming from the microprocessor, IC301, namely the DMSW, CLVH and ROT signals, the motor will not turn. These signals are then sent to the controller, IC402, before the turntable motor driver receives the motor signals.

If the CPU does not get a focus OK (FOK) and perhaps a tracking OK (TOK) from the focus and tracking circuits, the ROT, DMSW, and CLVH signals will be set to prevent the controller and motor driver from passing the PREF, PWR and PD signals to the motor. If all three signals remain high after pressing Play, check for FOK and TOK to the CPU. If one of the three signals is not normal, the CPU may be bad.

If your DMCA and DCMB drive signals are present, and the motor is turning but you are unable to set the output levels as listed, check all waveforms associated with the disc motor control section.

Begin at the controller and check for PWM, PREF and PD. If any of these are absent or abnormal, you can suspect the controller is bad. If not, track the signals between the motor and the driver. If the signals appear normal, check the waveforms and amplitudes as prescribed in the manual.

The focus control chip, IC601, receives the DSLC and the PREF signals from the signal processor, IC401 to create the EFM signals which are then returned



**Figure 3:** Typical motor control circuit

**7/CD**  
CD Player

7/CD - TR	Troubleshooting and Repair
7/CD - TR - DM	Disc Motor

to the signal processor. If the EFM is not present, the signal processor, IC401 will not produce the PREF, PWM and PD signals. To check the EFM signals, check PSYNC, and ASYNC with a dual-trace scope. The signals should be synchronized and if either is missing or out of sync the problem lies in the signal processor.

The disc motor can be influenced by the signal processing circuit, so if a problem can't be fixed here, move to check the signal processing section.



## 7/CD - TR

### Troubleshooting and Repair

## 7/CD - TR - L

### Laser Adjustment

If any part of the laser assembly is determined to be bad, then the entire assembly will have to be replaced.

#### Laser Diode

The laser diode should not be adjusted unless the pickup has been replaced or troubleshooting has revealed a laser problem.

A typical laser diode can be damaged by surges in current. 150 mA is usually enough to damage a CD laser diode. Most players limit drive-current in the 40 to 70 mA range, with some as high as 100 mA.

Make sure the disc drawer is closed, or the chuck (CHU) switch is closed. If open, no power is applied to the laser. Check the laser diode by measuring the voltage across a resistor in series with the diode. You can then calculate the drive current as explained in the following paragraph.

If the recommended laser diode current is 30 to 60 mA, and the resistance used

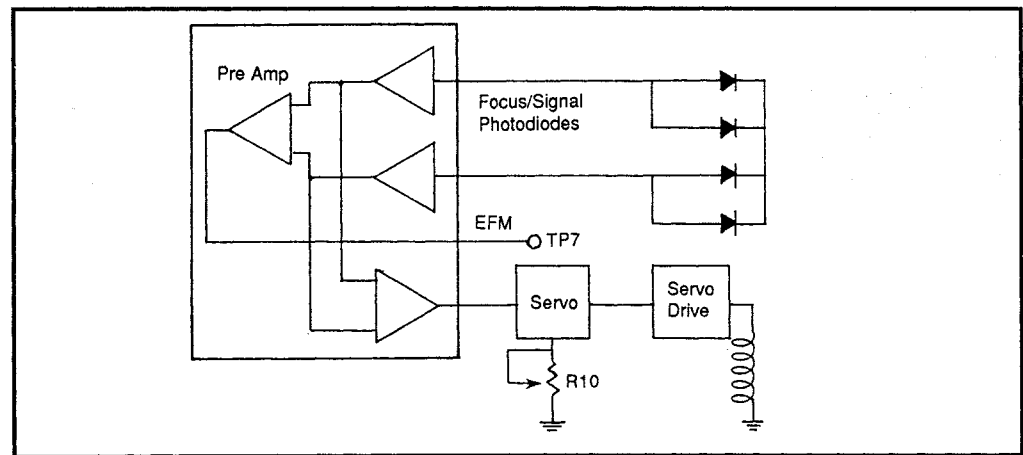


Figure 1: Oscilloscope connection to measure laser pick-up assembly's EFM signal

# 7/CD

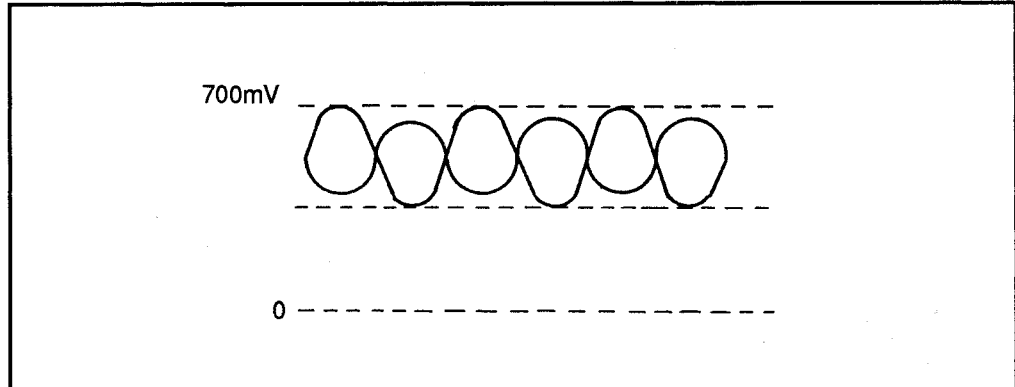
## CD Player

7/CD - TR

Troubleshooting and Repair

7/CD - TR - L

Laser Adjustment



**Figure 2:** EFM waveform at laser pick-up test point

is  $30\ \Omega$ , the voltage reading should be between  $0.90$  and  $1.80$  ( $30\ \text{mA} \cdot (1/30\ \Omega) = 0.90$ ;  $60\ \text{mA} \cdot (1/30\ \Omega) = 1.80$ ). Check the voltage before and after any adjustments are made to the laser diode.

Before making an adjustment, set the control voltage resistor to minimum (refer to the service manual), and then increase the setting as required.

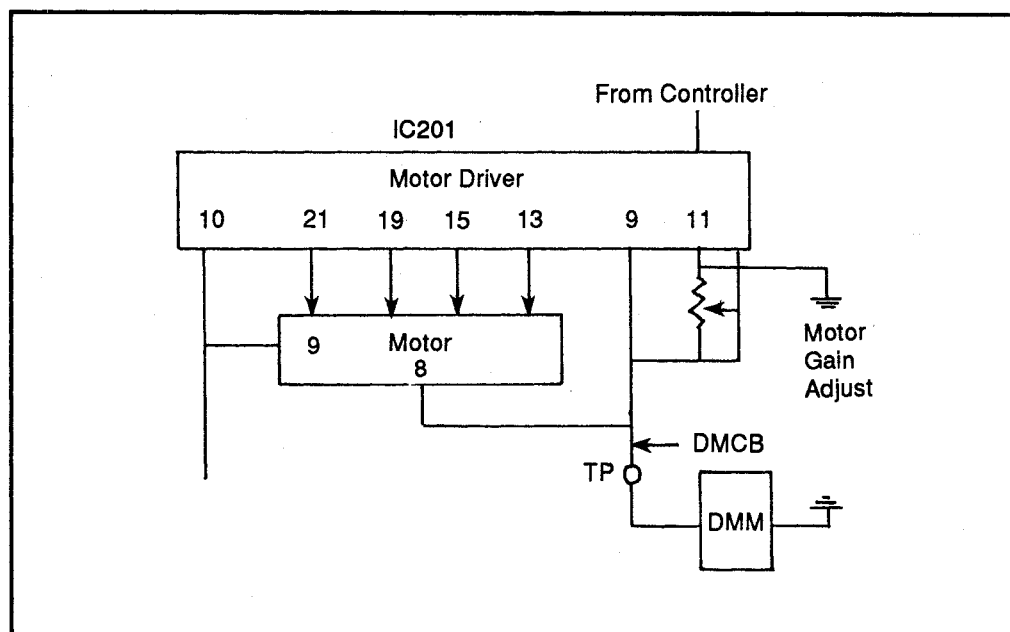
Connect your oscilloscope as shown in Figure 1. This allows you to measure the EFM signal. At this test point the EFM signal is applied to the tracking, focus, and pick-up motor servos and to the signal processing circuits.

Load a disc in the player and depress Play. You should see an EFM signal on the scope and it should produce a waveform similar to the one shown in Figure 2. Adjust the control voltage resistor until the EFM signal level is  $700\ \text{mV}$  or as specified in the service manual (usually between  $550$  and  $950\ \text{mV}$ ).

### Pick-up Motor Offset

The pick-up motor offset adjustment sets the point where the pick-up accesses the start of a disc. The program information may not be read properly if the adjustment is not correct. This adjustment controls the motor servo and should not be confused with the inner-limit microswitch. It is fairly easy to set.

Connect your DMM as shown in Figure 3, so you may monitor the motor gain output. Load a disc in the unit and depress Play. While the disc is playing, ground pin 11 of the motor driver, IC201, as shown, simulating a low TSW signal. (When TSW is high, the system shuts down.) Depress Stop after about 10 seconds and measure the DC level at TP99 and adjust R201 in very small increments so the voltage reading is  $0\ \text{V}$  ( $\pm 50\ \text{mV}$ ). The voltage may not stabilize very quickly.



**Figure 3:** Hook-up configuration to monitor gain output

### Tracking Servo Offset

Figure 4 shows the tracking servo offset adjustment diagram. The optical pick-up is adjusted here through the servo and tracking actuator coil so that the laser beam is centered properly on the tracks. This produces a proper EFM signal.

Connect an oscilloscope to TP13. The servo offset adjustment will offset the two tracking diodes, but not the four focus/signal diodes.

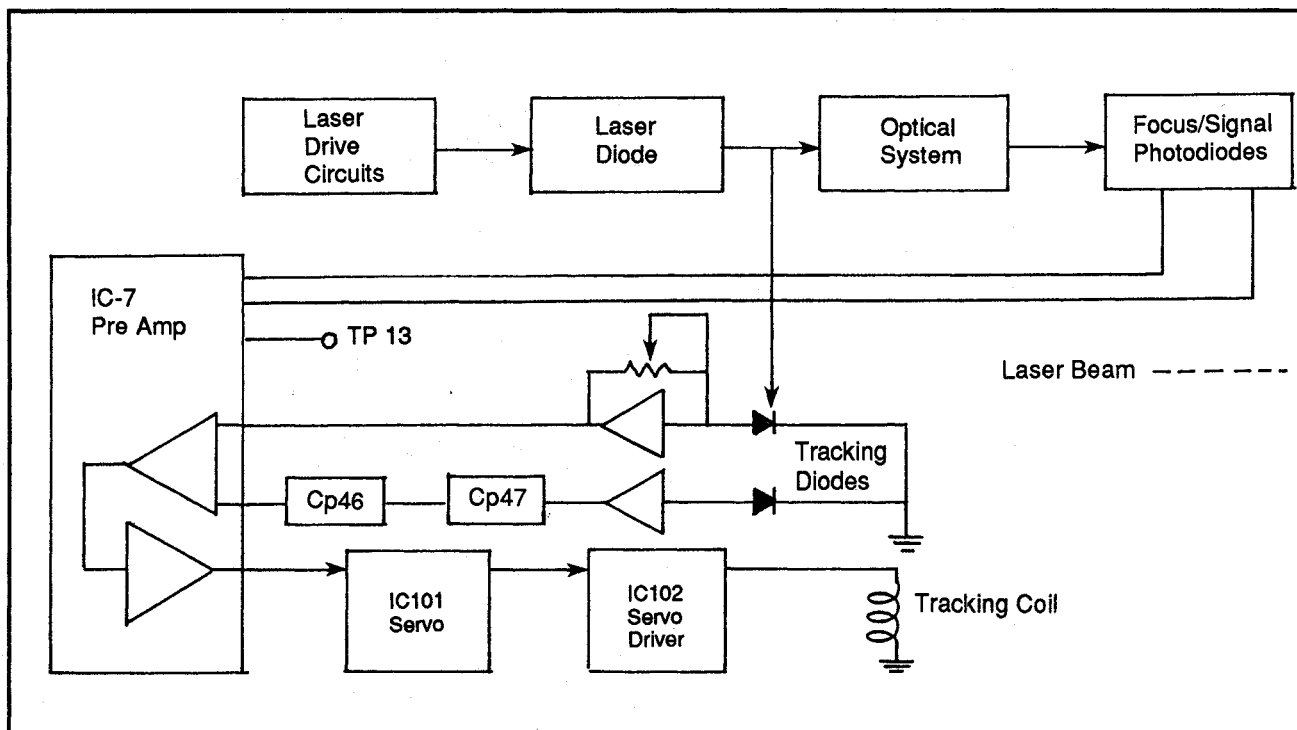
Load a disc in the player and depress Play. Adjust the servo offset until the EFM is at maximum amplitude. This will indicate that the EFM is at maximum amplitude. Some players may be unforgiving at this point and act erratically after this adjustment. Press Stop and then Play again and the problem should be fixed.

### Focus Circuit

This adjustment changes the optical pickup through the servo and focus actuator coils so the laser is properly focused on the tracks. Connect the oscilloscope to TP13 as shown in Figure 5. Load a disc as before and depress Play. An EFM waveform should appear on the scope screen. Adjust R115 for the maximum EFM signal. You may have to stop and restart the disc after this adjustment.

### Laser Diode Circuits

If symptoms arise that cannot be explained, suspect the laser circuits. If the laser appears to be nonoperative, check if +5 V is getting to the chuck switch. When the chuck is open, +5 V are sent to pin 47 of the CPU, IC301, which shows a tray



**Figure 4:** Tracking servo offset adjustment

open status or that the clamp is not dropped. The CPU will be disabled in several sections when this happens. When the clamp is fully dropped, the chuck switch closes and the laser diode receives power from the laser transistor.

If the laser diode has power, look for a low signal at pin 51 of the CPU, test point 14. If that signal is not present suspect the CPU. If present, check for a signal at the laser controller, IC604, from the monitoring diode. If none is found the monitoring diode and/or laser adjustment may be bad.

If the laser controller has signals present at pins 5 and 6, look for a drive signal at pin 7 of the laser controller and the base of the laser transistor. If not present, suspect the laser controller. If present, suspect the laser transistor.

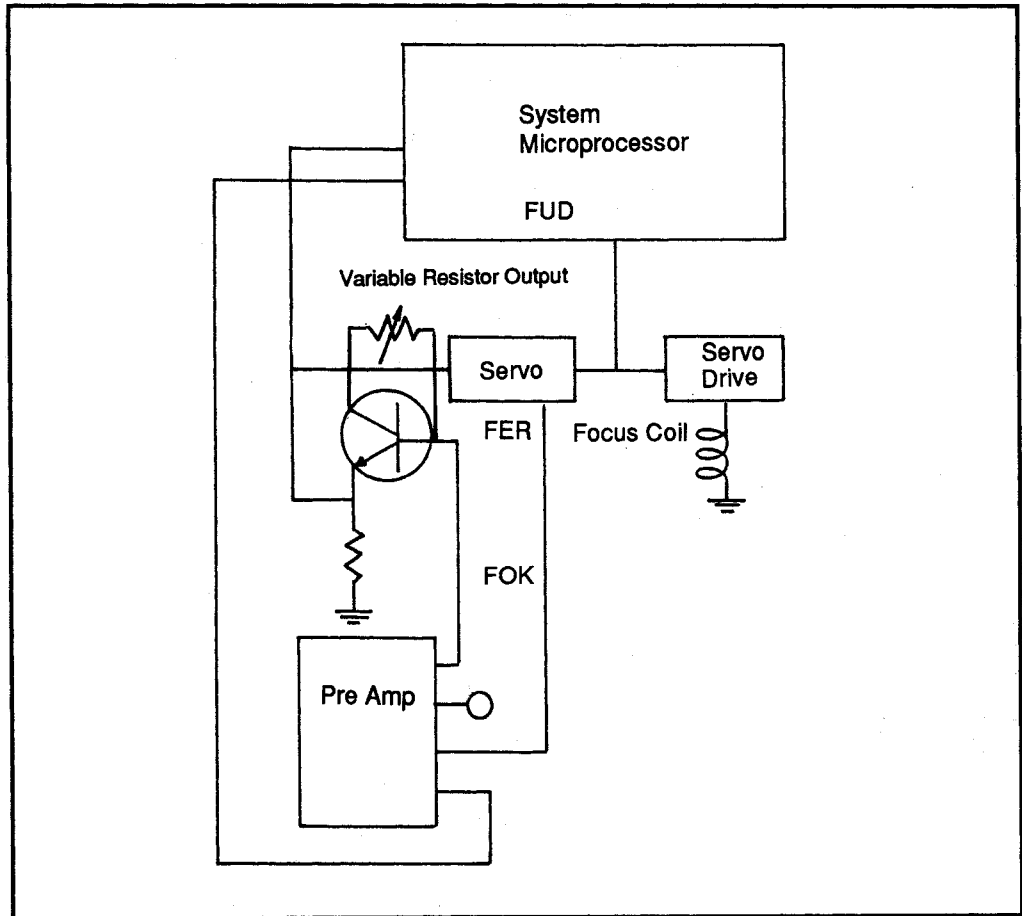


Figure 5: Hook-up configuration to monitor the focus control circuit

**7/CD**  
CD Player

---

7/CD - TR

Troubleshooting and Repair

---

7/CD - TR - L

Laser Adjustment

---

# 7/CD

## CD Player

7/CD - TR

Troubleshooting and Repair

7/CD - TR - PM

Pick-up Movement

## 7/CD - TR

### Troubleshooting and Repair

## 7/CD - TR - PM

### Pick-up Movement

#### No Pick-up Movement

When the pick-up first receives power it moves to the inner-most track. The CPU, IC301, applies a temporary reverse (SLR) signal to the pickup servo IC101. A reset signal is created by a combination of three transistors and applied to pin 24 of the CPU. There is a temporary SLR signal sent to the motor through the pick-up servo, the laser controller and servo driver, (IC102) which cause the pickup to move inward until the inner-limit S01 is moved.

If the pick-up does not seem to move when the power is applied, check for SLR at pin 60 of the CPU. If none is found you can suspect that the CPU or reset circuit are bad. If SLR is present, but the motor does not run, suspect the pick-up servo, the laser controller, the servo driver and/or the motor as well.

#### Pick-up Does Not Focus Properly

When play begins, the CPU sends the focus up down (FUD) signal to the pick-up servo and the servo driver, which moves the focus actuator coil. Once okayed, a focus-ok (FOK) signal is created by the focus controller, IC601, and applied to the pick-up servo and the CPU. If the CPU does not receive the FOK signal after a few tries it stops the system.

After focusing, the focus error (FER) signal from IC601 is applied to the actuator through the pick-up servo and the servo driver. It keeps the pick-up focused on the disc. When a problem is suspected in the automatic focus (AF), install a disc, press Play, and check to see that the pick-up moves up and down a few times and then stops. If this does not happen, check the laser and adjust if necessary.

To measure the resistance of a focus and tracking coil, use your DMM. The resistance of the focus coil will be around 20  $\Omega$ , and the resistance of the tracking coil will be 4  $\Omega$ . If you read a short or open circuit you may have to replace the actuator.

If the FUD pulses are not present after selecting Play, you can suspect the CPU. At pin 50 of the CPU, pins 35 and 36 of the pick-up servo, and pins 6 and 7 of the servo driver. Also check for FOK signals at pin 34 of the pick-up servo, pin

# 7/CD

## CD Player

7/CD - TR

Troubleshooting and Repair

7/CD - TR - PM

Pick-up Movement

13 of the CPU, and pin 8 of the focus controller. The LASW signal must be applied to pin 9 of IC601 for the FOK signal to be generated.

Check for the FER signals at pins 6 and 7 of the focus controller. If present at pin 6 but not at 7, suspect the servo driver. Suspect the focus controller if the FER signals are not present.

If the focus/signal photodiodes are suspected as being bad, check the EFM signal at test point 13. If you receive a good EFM signal, all photodiodes are good.

### Pick-up Is Not Tracking Properly

Try fixing tracking problems first as mentioned in the Section "7/CD - TR - L". Tracking can be caused by a variety of problems.

If the tracking error (TER) signal is not present, the pickup motor and the radial tracking coil will have no control signal. Also, if there is no FOK signal at the pick-up servo the TER will not be passed to the tracking actuator.

Next, check the tracking actuator coil. Then check to see if the pickup unit actually moves to the inner limit when power is first applied. This should tell you that the pickup motor, servo and reset circuits are good.

If you have a good motor and coil and can't seem to correct the problem with adjustments. Trace the TER from its source to the pickup motor and the tracking actuator coil. If TER does not reach the servo driver, the pick-up servo may be the problem. But the pick-up servo must receive several signals before it will pass the TER signal. Some of the signals that need to be present are the FOK and TSW signals. The TER signal is also being checked for errors by the pick-up servo. The pick-up servo should be checked for proper signals and voltages via the service manual.



## 7/CD - TR

### Troubleshooting and Repair

## 7/CD - TR - SP/AC

### Signal Processing/Audio Circuits

#### Signal Processing Circuit

Malfunctions of the signal processing circuit can cause a variety of problems in the disc motor and the audio circuits. While it is difficult to determine errors in the signal processing circuit, there are some tests that can narrow down the source of difficulty.

Begin by checking for audio at output pin 17 of the D/A converter, IC403. You should see the left and right channel low-level audio. If a signal is not found, the problem may be in the signal processing section.

If the front panel appears to be normal, and there is an excessive amount of audio dropout, the problem could again be with the signal processing circuits.

Check all of the waveforms associated with the signal processing section as prescribed in the manufacturer's service manual.

The 4.3218 MHz signal should be present at TP2, the MCK of the signal-processing module. If that signal is missing, perhaps the clock, IC401, or the signal processing circuit are faulty. Check PSYNC and ASYNC for 7.35 kHz signals. The PSYNC signal will be present in both Stop and Play but the ASYNC will only be present during Play.

The focus controller, IC601, must be receiving the PREF and DSLC signals. They are returned to the signal processing section as square wave EFM signals. If the EFM signals are not present, check to see if the high EFM signals are present at pin 20 of the focus controller.

Between the CPU, IC 301, and the signal processing section should be all related signals like ROT, CLVH, etc. Check each line with a scope for the presence of these signals. If one or more signals are missing, the CPU can be suspected of being faulty. The microprocessor and the signal processor are dependent on each other, so one may cause the other to have improper signals. Check the TC1 and TC2 signals. These signals indicate the accuracy of the decoding processes inside

**7/CD**  
CD Player

---

7/CD - TR	Troubleshooting and Repair
7/CD - TR - SP/AC	Signal Processing/Audio Circuits

---

the signal processing module. They should produce a 7.35 kHz signal during Stop and up to a 200 Hz signal during Play. If not, suspect the signal processing section. Next, check for the accuracy of the sync signals and detection functions in the signal processing section at BFR and EFR. BFR should be zero during playback but not when there is a groove skip. EFR may have a signal present, but this should be below 50 Hz.

**Audio Circuit**

Begin by monitoring the output of pin 17 of the D/A converter, IC406. Next, check to see if the SHR and SHL, the sample and hold signals, are present from the signal processing module. If audio is present at the D/A converter and the SHR/SHL signals are present, trace the signal to the output jacks. Look for any emphasis or muting signals from the CPU and/or the signal processing section.

# 7/R Radio

7/R - F	Features
7/R - F - A	Antenna

## 7/R - F Features

## 7/R - F - A Antenna

### AM Antenna System

A compact AM antenna usually consists of a paper-wrapped ferrite core with a coil of wire winding around the paper wrap. By moving the winding across the ferrite core, adjustment for the best possible signal reception is possible. Figure 1 shows a typical antenna for an AM radio receiver.

### Testing and Alignment

To test and align the AM antenna, free the antenna winding so it can move along the ferrite core. A cement solvent may be needed for cemented windings; or you may have to break the wax seal by loosening it with your fingers.

Tune the receiver to the low end of the dial or to any weak station near 600 kHz. Slide the antenna winding back and forth to receive the best possible signal. Next, tune the receiver to the high end of the dial for a weak station around 15 kHz. Adjust the antenna trimmer capacitor for the maximum volume.

Continue this until the best possible signal is obtained on both the low and high ends. It may seem like nothing is happening, but even a slight movement will cause the reception of a weak station to change.

Another method for measuring the performance of an antenna is to use a dip meter. The dip meter should be able to tune the same range (or greater) as that of the receiver.

The dip meter is connected to the receiver antenna (usually magnetically). Tune the receiver to the low end of its dial. Tune the dip meter to the same frequency and see if the meter dips. If you are getting a good strong dip, the antenna is operating properly at this frequency. Check several frequencies to see if they are operating correctly. A good dip at each frequency indicates good antenna areas. If not, check the antenna connections, lead-in and other components in the antenna system.

### FM Antenna System

The antenna system consists of the antenna, antenna amplifier (if used), and down-lead coaxial cable (if used). An easy check of these devices is to hook a

# 7/R

## Radio

7/R - F	Features
7/R - F - A	Antenna

known good FM receiver to the antenna. Replacing the cable between the receiver and the antenna (or antenna amplifier) can determine a bad antenna or a bad cable. Bypassing the antenna amplifier can determine if the problem is in the antenna amplifier or the antenna itself.

### Antenna

The primary function of the antenna is to collect the FM signals. Any bent or broken elements can change the ability of the antenna to collect a signal and to resonate at the right frequency. A higher antenna must be aimed more accurately because the antenna will reject signals that are not within the antenna pick-up path. The antenna connection may also be damaged or corroded to the point of not allowing proper contact with the connecting cable or amplifier.

### Antenna Amplifier

The antenna amplifier, increases the signal before it reaches the tuner, thereby reducing the possibility of any additional noise being introduced on the way there. The connections must be clean and good. Also, the amplifier will be powered. Make sure the power is present before fixing a suspected bad amplifier. The amplifier is a broadband amplifier. This means it amplifies the entire FM range covered rather than just one specific frequency.

### Tip

TV antennas cannot always be used as FM antenna. Some TV antennas use an FM trap that rejects FM signals.

### Antenna Cable

The downlead cable generates noise and signal losses. Cracks and sharp bends can change the cable parameters, especially if the downlead is of the 300  $\Omega$  twinlead type.

Sharp bends can cause the impedance in the cable to change. Poor impedance matching is a sure sign of problems. Hooking a 75  $\Omega$  cable to a 300  $\Omega$  system without the proper impedance match should be avoided.

# 7/R

## Radio

7/R - F	Features
7/R - F - M	Modulation

## 7/R - F

### Features

## 7/R - F - M

### Modulation

#### Amplitude Modulation

The first radios were amplitude modulation (AM) tuners. These tuners cover the 540 to 1600 kHz spectrum and are usually of the superheterodyne type. As described above, a superheterodyne receiver is one in which the desired signal mixes with a locally generated signal to produce an intermediate-frequency (IF) signal. This IF signal is then detected to create the audio frequency.

Amplitude modulation is the process of changing the amplitude of an RF carrier. An unmodulated signal of an AM signal is at a constant frequency and amplitude, whereas a modulated frequency signal is varied.

In AM, the music or speech is used to modulate the carrier. The intelligence to be transmitted varies some property of the carrier. By superimposing the intelligence on the carrier by varying the amplitude of the carrier, amplitude modulation is created.

#### Frequency Modulation

Frequency modulation tuners occur in the VHF (very high frequency) region of the spectrum. For radio this FM bandwidth is from 88 MHz to 108 MHz. FM transmissions require a line of sight to be received and generally have a range of 15 to 65 miles. (Line-of-sight AM doesn't carry as far. However, AM signals can bounce off the ionosphere back to earth back to the ionosphere and can thus travel great distances.)

Frequency modulation (FM) is the process by which the frequency of a signal varies from a set center frequency while the amplitude of the frequency remains constant.

FM receivers also use the superheterodyne principle. Both FM and AM use the same basic types of circuits, with FM having a ratio detector that rejects any amplitude differences on an incoming signal.

**7/R**  
Radio

---

7/R - F

**Features**

---

7/R - F - M

**Modulation**

---

# 7/R Radio

7/R - F	Features
7/R - F - T	Tuners
7/R - F - T - AMT	AM Tuners

## 7/R - F - T Tuners

## 7/R - F - T - AMT AM Tuners

### Introduction

AM radios have an RF preamplifier to reduce image interference, a first detector and oscillator to convert the signal to a lower frequency where the RF amplification is better. At this point there is a second detector to remove the sound signal from the carrier signal and an audio amplifier and output system to set the signal at a level sufficient to drive a basic audio amplifier.

### AM Wave

An AM wave is composed of various frequencies which make up the sideband frequencies. These frequencies are: the radio frequency of the carrier wave, the modulating audio frequency or frequencies, and combinations of these frequencies.

When two frequencies are combined, two new frequencies are created. One frequency is the sum of the two, and the other is the difference between them. For example, a modulated frequency of 5000 Hz (5 kHz) and a carrier of 5000 kHz would produce sidebands of 4995 and 5005 kHz.

### Bandwidth

When a RF carrier is modulated by many audio frequencies, like music or speech, the side frequencies consist of a band of many frequencies above and below the carrier frequency. The width of this band of frequencies is determined by the highest modulating frequency. To be reconstructed, Hi-Fi AM signals must have an available bandwidth equal to twice the highest frequency.

Figure 1 shows the block diagram of a simple superheterodyne AM receiver. This circuit creates the IF signal used to generate the audio frequency.

The RF amplifier stage receives the weak signal picked up by the antenna, amplifies it and then passes it to the mixer. The mixer then heterodynes the signal with the internal oscillator and outputs an IF signal. The IF amplifier (there may be more than one) then amplifies this signal and applies the signal to the second detector. This stage then removes the IF component from the signal and sends the undistorted audio signal to the circuits for processing. They are then sent to

# 7/R Radio

7/R - F	Features
7/R - F - T	Tuners
7/R - F - T - AMT	AM Tuners

the speaker. These circuits may include preamplifiers, amplifiers, equalizers or any other audio processing circuits.

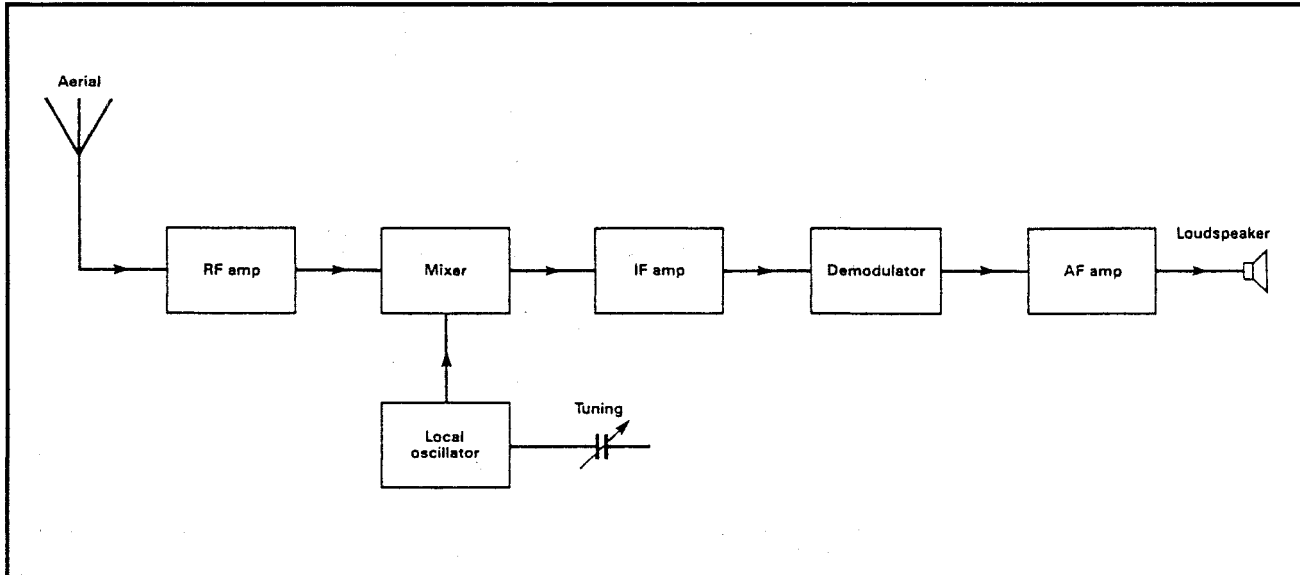


Figure 1: Block diagram of a superheterodyne AM receiver

## Frequency Conversion

The converter stage is composed of the mixer and the local oscillator. The converter creates the IF signal which has the same modulation characteristics as the received signal. An unmodulated RF signal is created in the receiver and is heterodyned (mixed with or beat against) with the incoming RF signal. The IF is created, which is a frequency that is equal to the difference between the locally generated and incoming signal frequencies.

Figure 2 shows a typical converter made from transistor-type circuits. The RF input is coupled to the mixer tuned circuit by means of a coupling coil. This circuit is tuned to the frequency of the incoming signal and is applied to the mixer base.

## Oscillator

The oscillator operates at a frequency equal to the incoming signal plus the intermediate frequency. The output from the oscillator is coupled to the mixer base through a capacitor. The signal then applied to the mixer is the product of the incoming frequency and the oscillator frequency.

This combined signal then appears at the mixer output. This output is then applied to the IF amplifier.



# 7/R Radio

7/R - F

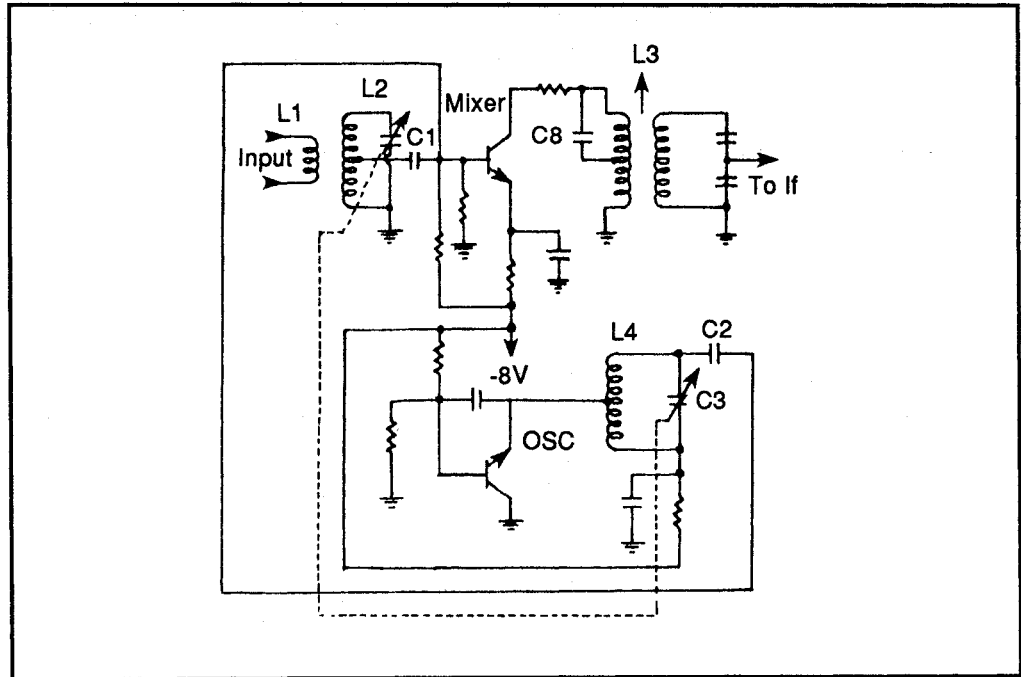
Features

7/R - F - T

Tuners

7/R - F - T - AMT

AM Tuners



**Figure 2:** Converter with separate mixer and oscillator

## IF Amplifier

The IF amplifier creates most of the amplification found in a superheterodyne circuit. It is located in a metal box in most modern radios. There may be anywhere from one to three IF amplifier stages used. Figure 3 shows a typical IF amplifier.

The input and output circuits are inductively coupled by the use of two IF transformers. The primaries and secondaries of the transformers are tuned. The incoming IF signal is always heterodyned to the same intermediate frequency (typically either 455 kHz or 10.7 MHz). Therefore, the four tuned circuits operate at the same frequency at all times. Variable capacitors control the proper frequency adjustment of the IF transformers, which are mounted in small metal cans.

There is a high gain in IF amplifiers, so the coupling between the input and output must be kept to a minimum. This is accomplished by careful shielding and placement of parts and by providing suitable decoupling networks. A decoupler network is usually a resistor and capacitor connection.

## Second Detector

The purpose of the second detector is to remove the IF component from the signal. It then outputs the audio that was impressed on the carrier at the transmitter.

**7/R**  
Radio

7/R - F

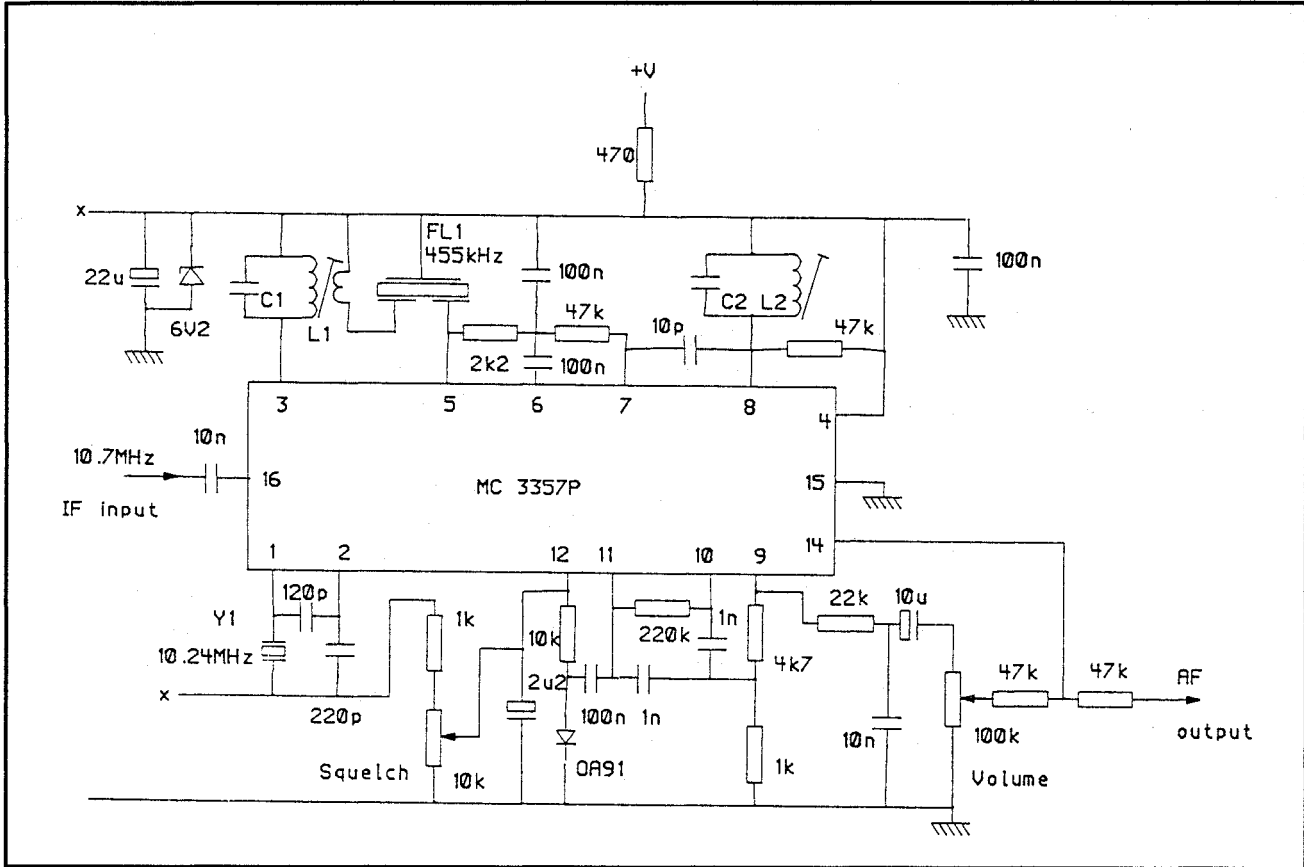
Features

7/R - F - T

Tuners

7/R - F - T - AMT

AM Tuners



**Figure 3:** IC based IF amplifier circuit

The diode detector is used in lower cost receivers because it is simple and effective.

The emitter follower has a low-impedance output, allows the use of longer lines to feed the amplifier unit, has a simple impedance-matching arrangement, and less feedback.

Many of the current radio receivers use some kind of IC detector circuit. The detector circuit is designed to eliminate alternate half-cycles of the waveform and to detect the peaks of the remaining half-cycles to create the output voltage. The diode detector is basically a half-wave rectifier. When the signal on the anode swings positive, the diode conducts, and rectified current is sent to the capacitor and load resistor. The voltage varies across the capacitor in agreement with the rectified amplitude of the carrier and then reproduces to AF signal. The capacitor tends to smooth out the RF or IF variations.

# 7/R Radio

7/R - F

Features

7/R - F - T

Tuners

7/R - F - T - AMT

AM Tuners

## Automatic Gain Control

The automatic gain control (AGC) may be used between the second detector, the IF amp and the RF amp. The purpose of an AGC is to maintain a constant output from a receiver when the amplitude of the incoming signal varies. Figure 4 shows the block diagram for an AGC circuit as related to the other circuits.

The AGC rectifies part of the received signal at the output of the IF amplifier and creates a voltage across a suitable resistor. The magnitude of the voltage is proportional to the amplitude of the incoming signal. If the incoming signal decreases, the AGC bias decreases and the receiver gain raises.

## Automatic Frequency Control

The automatic frequency control (AFC) circuit is used in many superheterodyne receivers to compensate for frequency drift. There may be drift due to small changes in the oscillator or in the carrier frequencies. The AFC adjusts the oscillating frequency to compensate for changes. The AFC consists of two basic parts: a frequency detector and a variable reactance circuit. These circuits may be contained in a single IC and linked to the oscillator

## Squelch

Many tuners in transceivers, as well as some of the better receivers, may have a circuit that detects noise level in the signal and turns the output off if the noise is too loud. This is known as the squelch control.

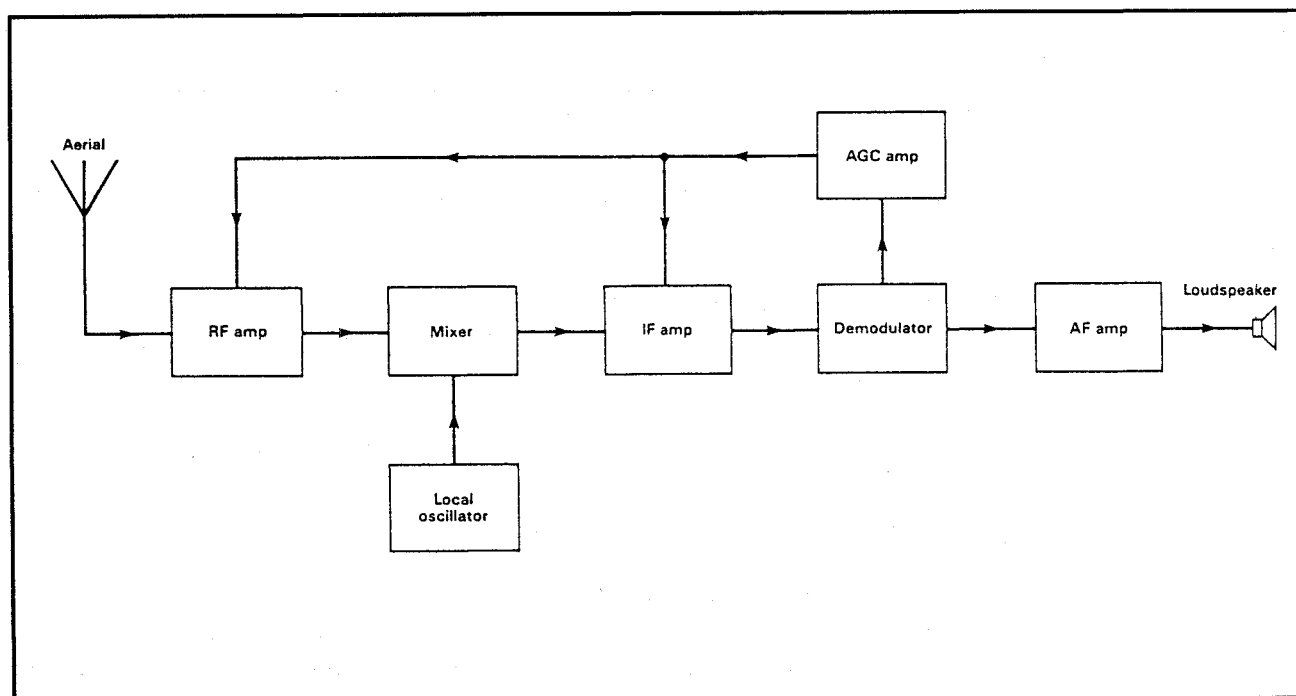
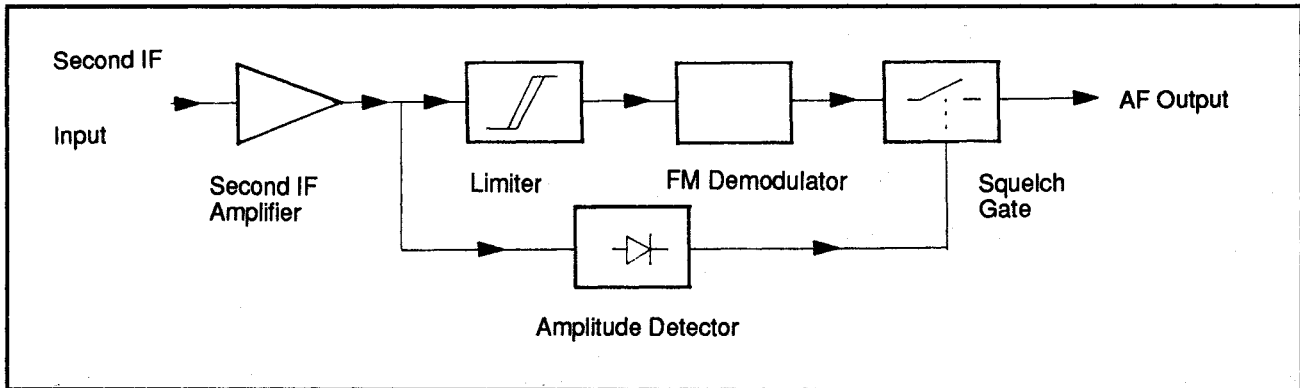


Figure 4: Block diagram of AGC application

**7/R**  
Radio

7/R - F	Features
7/R - F - T	Tuners
7/R - F - T - AMT	AM Tuners



**Figure 5:** Basic squelch circuit

Figure 5 shows a basic squelch circuit. Noise always contains a high percentage of high audio frequencies above the 3 kHz maximum that amateur voice communications use.

When a carrier is not being received, the 3 kHz highpass filter (C1R1 and C2R2) is being fed high-amplitude, high-frequency AF noise energy from the discriminator. The diode rectifies this noise and creates a downward DC current through variable resistor R3.

Since the voltage-drop across this resistor is negative at the top, it places a high negative bias on the AF amplifier's gate circuit. The AF amplifier is driven into stopping (squelching) all output sound from the AF amplifiers.

# 7/R Radio

7/R - F

Features

7/R - F - T

Tuners

7/R - F - T - FMT

FM Tuners

## 7/R - F - T Tuners

## 7/R - F - T - FMT FM Tuners

### Introduction

The basic function of an FM tuner is to receive a frequency modulated signal, separate the audio information, and send it to the system for use. It is essential to have a good strong signal before troubleshooting an FM tuner. Use another good working unit hooked to the same antenna as the unit being tested to see if the signal is good. If neither tuner functions, you know that the problem is within the antenna system (which includes the downlead). Figure 1 shows a typical FM tuner block diagram.

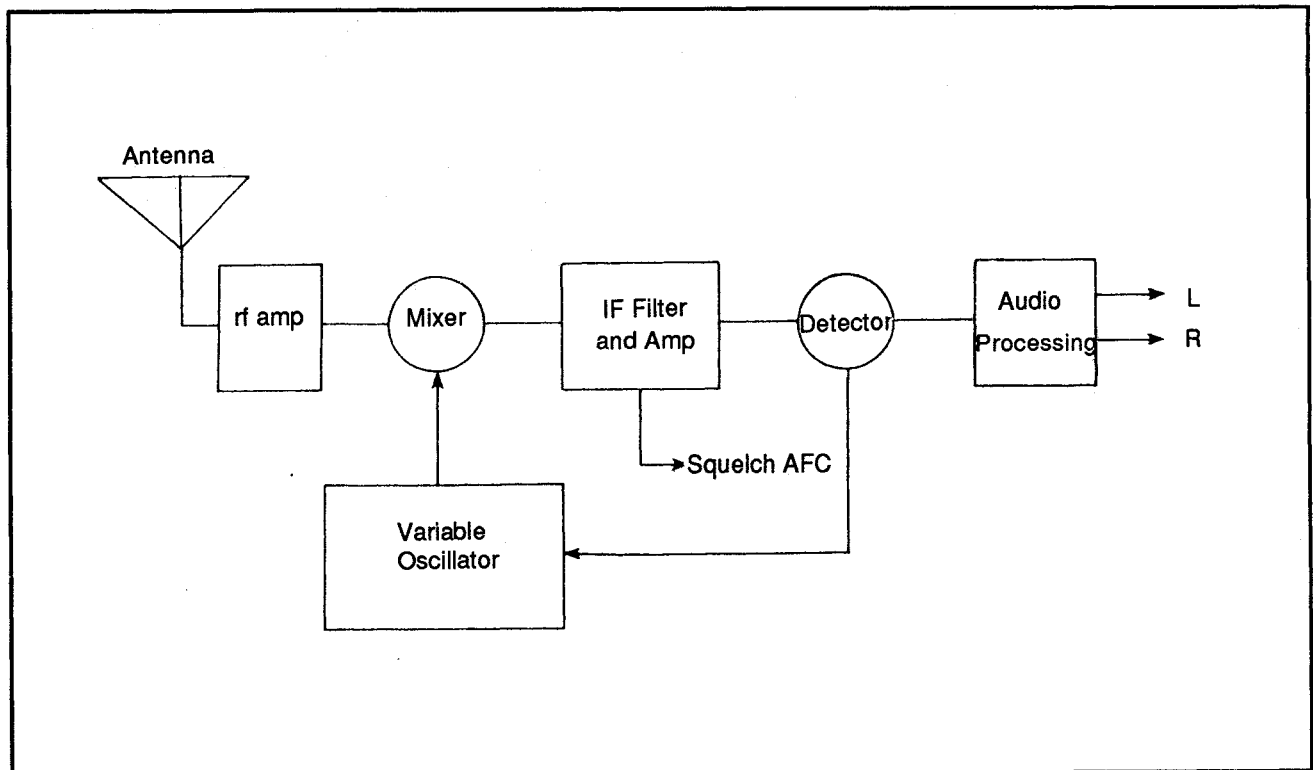


Figure 1: FM receiver tuner section

# 7/R

## Radio

7/R - F	Features
7/R - F - T	Tuners
7/R - F - T - FMT	FM Tuners

The signal received is frequency modulated with the center frequency at one of the assigned frequencies within the 88.1 and 107.9 MHz spectrum. The maximum allowable deviation from the center frequency (modulation) is  $\pm 75$  kHz with a safety band of 25 kHz above and below. Thus, the spacing for stations along the FM band is set at 200 kHz intervals.

### RF Amplifier

The incoming signal is amplified by the RF amplifier. The circuit is similar to that of an AM RF amp but must be able to handle frequencies to 108 MHz.

When replacing Q transistors within RF circuits one must remember the quality control factor. The Q transistors must be within the given frequency range for the RF circuit being tested. Replacing a Q transistor in a circuit with a Q transistor outside the spec range (i.e., a 450 to 512 Q transistor is replaced with a 350 to 420 Q transistor) may be more harm than good.

### Oscillator

The oscillator of an FM tuner is kept at exactly 10.7 MHz above the station being tuned by the RF section. These FM oscillators may use mechanically tuned variable capacitors, voltage-variable capacitive diodes, phase-locked loops or other tuning means. AFC voltages may be received from the IF to adjust its frequency as needed for the strongest output to the IF. Figure 2 shows a typical oscillator stage.

### Mixer

Combined in the mixer in the same fashion as the AM mixer is the oscillator 10.7 MHz signal and the incoming signal. If part of the 88 to 108 MHz bandwidth is distorted or attenuated, the oscillator and RF amplifier will not shift together to create the required 10.7 MHz IF for all tuned frequencies. Figure 3 shows a typical mixer stage.

### Filter and IF Section

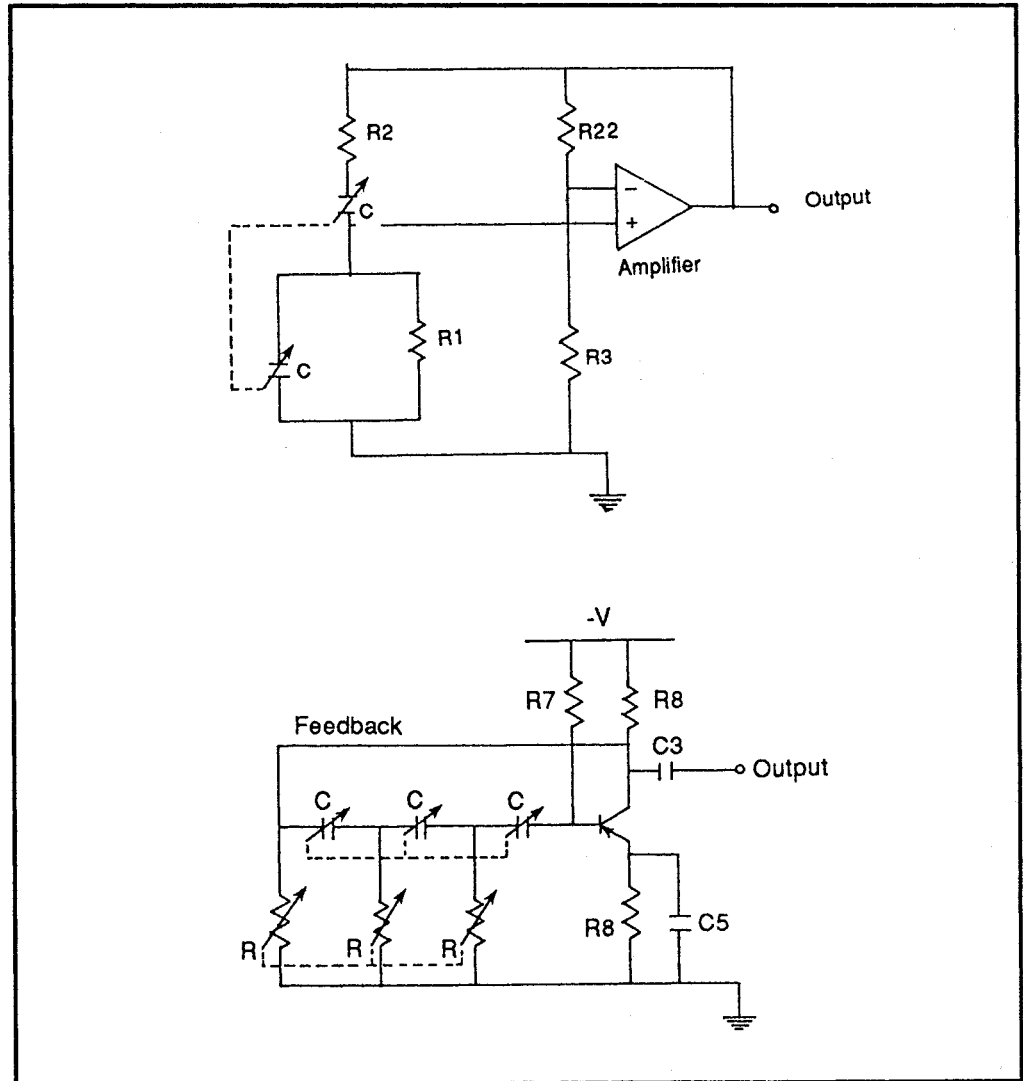
Miscellaneous signals may reach the IF through the mixer besides the 10.7 MHz signal. The miscellaneous signals may need to be filtered out at the IF input. Any amplitude modulation in the FM signal is limited (removes the RF voltage peaks so each cycle has the same amplitude).

The input FM sinewave is amplified to create a chopped-off FM squarewave. If there is a loss of output, it may indicate that one of the amplification stages of the IF has failed. If so, each input and output should be checked.

Realigning of the IF should not need to be done very often. Modern FM IF circuits do not drift due to heat. If there is a problem (indicated by poor sensitivity or distortion in the audio), inject a small unmodulated 10.7 MHz signal at the first stage of the IF and adjust for the maximum voltage output at the end of the IF strip. Start from the first IF and move to the last.

**7/R**  
Radio

7/R - F	Features
7/R - F - T	Tuners
7/R - F - T - FMT	FM Tuners



**Figure 2:** Oscillator circuit

The input signal should be reduced as you progress through the IF amps to avoid limiting. If not, there will be no way to tell if the adjustments are making any improvement.

**Detector**

As with AM, the FM detector separates the information from the modulated carrier (in FM, the 10.7 MHz carrier). The amplitude is determined by how much the IF frequency varies from the 10.7 MHz center. The frequency of the audio signal is determined by how rapidly the IF frequency deviates above and below the 10.7 MHz signal. If the detector is faulty, it will attenuate (reduce) or even block the signal it receives.

**7/R**  
Radio

7/R - F

Features

7/R - F - T

Tuners

7/R - F - T - FMT

FM Tuners

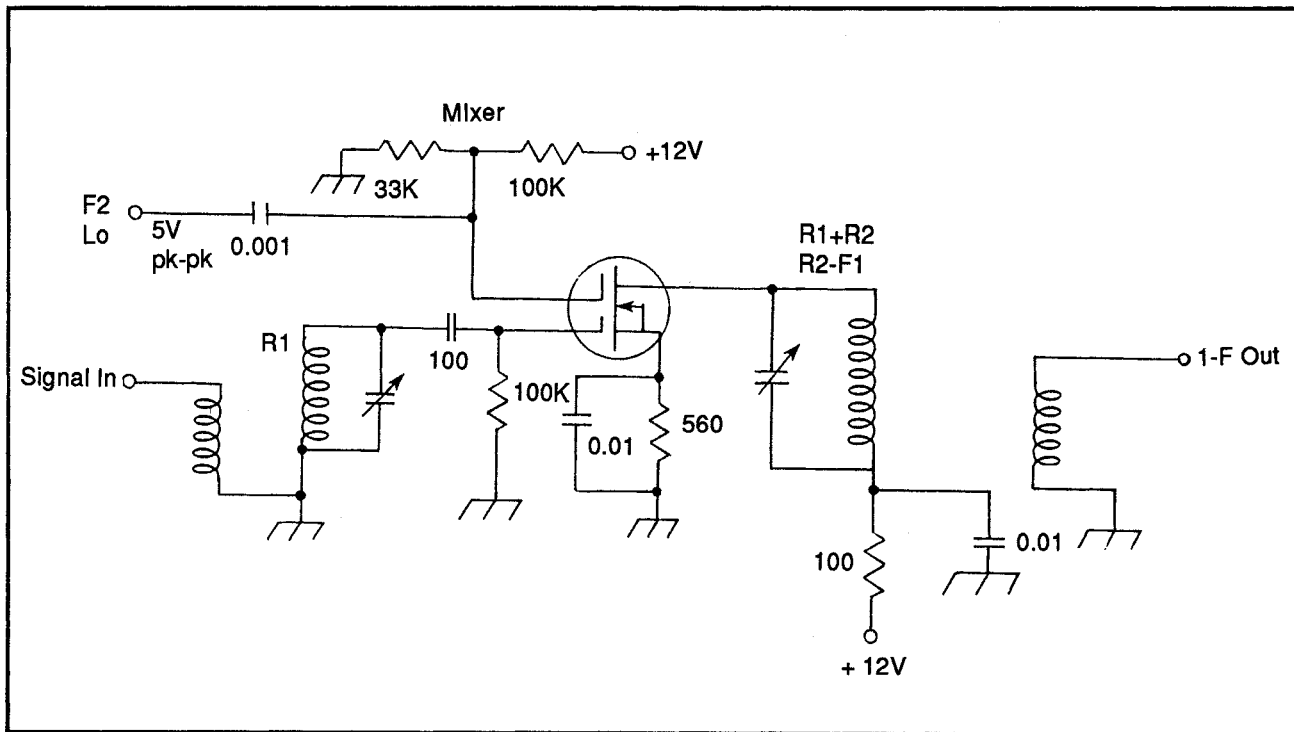


Figure 3: Mixer stage circuit



## 7/R - TR

### Troubleshooting and Repair

## 7/R - TR - A

### An Introduction

#### Transmitters

##### Troubleshooting RF Systems

An RF transmitter—CB radio, commercial AM or FM, aircraft, marine radio telephone or ham gear—is relatively simple in design. It is invariably easier to service and quicker to diagnose than a receiver.

##### Watt-Meter

When testing complete RF systems (transceivers), test the transmitting sections first. Begin by using a watt-meter to measure the output.

##### Field-Strength Meter

Next, measure the modulation and the standing wave ratio (SWR). A field strength meter checks the transmitter for optimum efficiency. All of these meters are inexpensive. Quite often, more than one will be built into the same unit.

Standing waves on antennas and transmissions are those waves that travel out and are reflected back. For example, a cord connected to a non movable object (like a wall) with a person at the other end who then imparts a wave to the cord will have a wave reflected back that is the reverse (phase reversal) of the wave sent out.

##### Reflectometers

The wattmeter/SWR meter can show how an antenna is reacting. In measuring the SWR, advantage is taken of the fact that the voltage on a transmission line consists of two components traveling in opposite directions. The power going from the transmitter to the load is represented by one voltage and the power reflected from the load by the other. This is acceptable when computing the SWR. These types of circuit bridges used to measure SWR are called reflectometers. SWR meters can be designed to match the transmitter and antenna for a proper SWR.

##### Frequency Counters

Frequency counters work great when testing RF signals, but one must be aware that the counter can lock onto the harmonics of a signal rather than the primary signal. Stray coupling between test leads or between circuit components can cause test problems. The smallest variance of a stray reactance (i.e. a resistor wire lead can easily become a small inductor at UHF frequencies) could make high frequency (HF) measurements more exacting.

## Preventing Problems

To prevent possible problems in RF testing, follow these steps:

- Calibrate RF test equipment at regular intervals using the internal calibration section (if available).
- Keep body parts away from unshielded oscillator circuits. Body capacitance can detune or reduce signal levels in an unshielded RF circuit. This may be caused by interference or improper grounding.
- Use a common ground point for all equipment: test equipment, circuits under test, etc.
- Avoid electrical noise pick-up. Electrical noise pick-up happens when leads are too long, when there is an improper power line filter, or with improper RF shielding. If radio interference is a problem, you may have to work in a shielded booth (screen room).
- Do not override the circuit under test. Use loose couplings between the circuit under test and the test instrument to prevent this problem. When a frequency counter is used with an antenna attached to it, vary the distance between the counter antenna and the circuit being tested until you have the least signal pickup possible while still being able to make a frequency count.
- Drift problems (a slow change in frequency) usually happen when testing before equipment has had a chance to warm up. Test equipment and equipment being tested need to be at the same temperature (room temperature) and stabilized before beginning troubleshooting.
- Keep all wire leads as short, straight, and as large in diameter wire as possible.

## Power Supplies

Every piece of electronic equipment has a power supply of some kind. Most take the AC current and convert it to DC. Audio equipment needs “clean” DC current in order to function properly.

The purpose of a power supply in audio equipment is to create a “clean” DC voltage (or voltages). This voltage must be absent of noise spikes or hum and must be at a DC level within acceptable limits for the device being powered. When DC is not clean, audio will most often have a hum or some other kind of noise.



7/R - TR	Troubleshooting and Repair
7/R - TR - Ch	Checklist

## 7/R - TR Troubleshooting and Repair

## 7/R - TR - Ch Checklist

Problems can be caused by a variety of things. This section should be valuable for most electronic receivers, transceivers, etc. Various symptoms and causes are listed below:

### Antenna Related Problems

Symptom	Cause
RFI (radio frequency interference)	Arcing or poor connections anywhere in the antenna system or nearby conductors.
SWR poor	A damaged antenna element, damaged feed line, balun failure, resonant conductor near antenna, damaged matching network, damaged lead dress or poor connection at the antenna.
Balun failure	Too much SWR, weather or cold-flow damage in the coil choke, or broken wires.

### Power Supply Problems

Symptom	Cause
No output voltage hum or ripplewinding	Open circuit (a fuse or transformer is most likely bad). Faulty regulator, capacitor or rectifier, low frequency oscillation.

### Amplifier Problem

Symptom	Cause
Low gain	Transistor, coupling capacitors, emitter-bypass capacitor, AGC component, alignment.

### Noise Problem

Symptom	Cause
Oscillation	Dirt on variable capacitor or chassis, shorted op-amp input.
Untuned (oscillations do change with frequency)	Audio stages.
Tuned	RF, IF and mixer stages.
Squeal	Open AGC-bypass capacitor.

# 7/R

## Radio

7/R - TR

Troubleshooting and Repair

7/R - TR - Ch

Checklist

### Noise Problems (cont'd)

Symptom	Cause
Static-like crashes	Arcing trimmer caps, poor connections.
Static in FM receivers	Faulty limiter stages, open capacitor in ratio detector, weak RF stage, weak incoming signal.
Intermittent noise	Any component or connection, band-switch contacts, variable resistors (especially in DC circuits), trimmer caps, poor antenna connections.
Distortion (continuous)	Oscillation, overload, faulty AGC, leaky transistor, open lead in tab-mount transistor, dirty variable resistor, leaky cap, leaky coupling, open bypass cap, imbalance in tuned FM detector, IF oscillations, RF feedback from cables.
Distortion (on strong signals only)	Open AGC line, open AGC diode.
Frequency change	Physical or electrical variations, broken switch, dirty or faulty trimmer cap, loose parts, poor voltage regulation, oscillator tuning.

### No Signals

Symptom	Cause
All bands	Dead VFO or heterodyne oscillator.
One band	Defective crystal, oscillator out of tune, band switch bad or faulty.
No function control	Faulty switch, poor connection, defective switching diode or circuit.

### Improper Dial Tracking

Symptom	Cause
Continuous errors across dial	Dial Drive.
Error grows worse along dial	Circuit adjustment.

### Modulation Problems

Symptom	Cause
Arcing	Dampness, dirt, improper lead dress.
Low output	Incorrect control settings, improper carrier shift (CW signal outside of bandpass), audio oscillator failure, SWR protection circuit, transistor or tube failure.
Transmit distortion	Defective microphone, RF feedback from lead dress, modulator imbalance, bypass capacitor, improper bias, or excessive drive.
No modulation	Broken cables, open circuit in audio chain, or defective modulator.

# 7/R

Radio

7/R - TR

Troubleshooting and Repair

7/R - TR - Ch

Checklist

## Miscellaneous Problems

Symptom	Cause
Key clicks	Keying filter, distortion in stages after keying.
Inoperative S meter, PA noise in receiver, excessive current on receiver, or arcing in the PA tank.	Faulty relay.
Reduced signal strength on transmit and receive	IF failure.
Poor VOX operation	VOX amplifiers and diodes.
Poor VOX timing	Adjustment incorrect, component failed in VOX timing circuits or amplifiers.
VOX consistently tripped by receiver audio	Anti-VOX circuits or adjustment failure.



---

7/R - TR	Troubleshooting and Repair
7/R - TR - Ch	Checklist

---

# 7/R

## Radio

7/R - TR

Troubleshooting and Repair

7/R - TR - CT

Circuit Tests

## 7/R - TR

### Troubleshooting and Repair

## 7/R - TR - CT

### Circuit Tests

#### Checklist

The best approach to testing receiver/transceiver circuits is signal tracing and signal injection. These methods are similar and the circuit under test determines which method is best to use.

Checking ICs in receivers/transceivers is very simple:

- the voltage is present and the IC works
- the voltage is present and the IC does not work
- the voltage is not present

In the first case, the IC is functioning and the problem is elsewhere. In the second case, replacing the suspected IC or IC circuit section is the best fix. For the third example, track the voltage backward to the power supply.

#### Aligning

Alignment of RF equipment does not shift suddenly. Do not assume that because a unit is working improperly it has gone out of alignment. It is most likely a circuit that has failed, not that a coil has changed in alignment. Don't start changing coil alignments (especially without the service manual) unless it has been determined that the alignment has changed. Signal tracing is the best method for determining this.

#### Signal Tracing

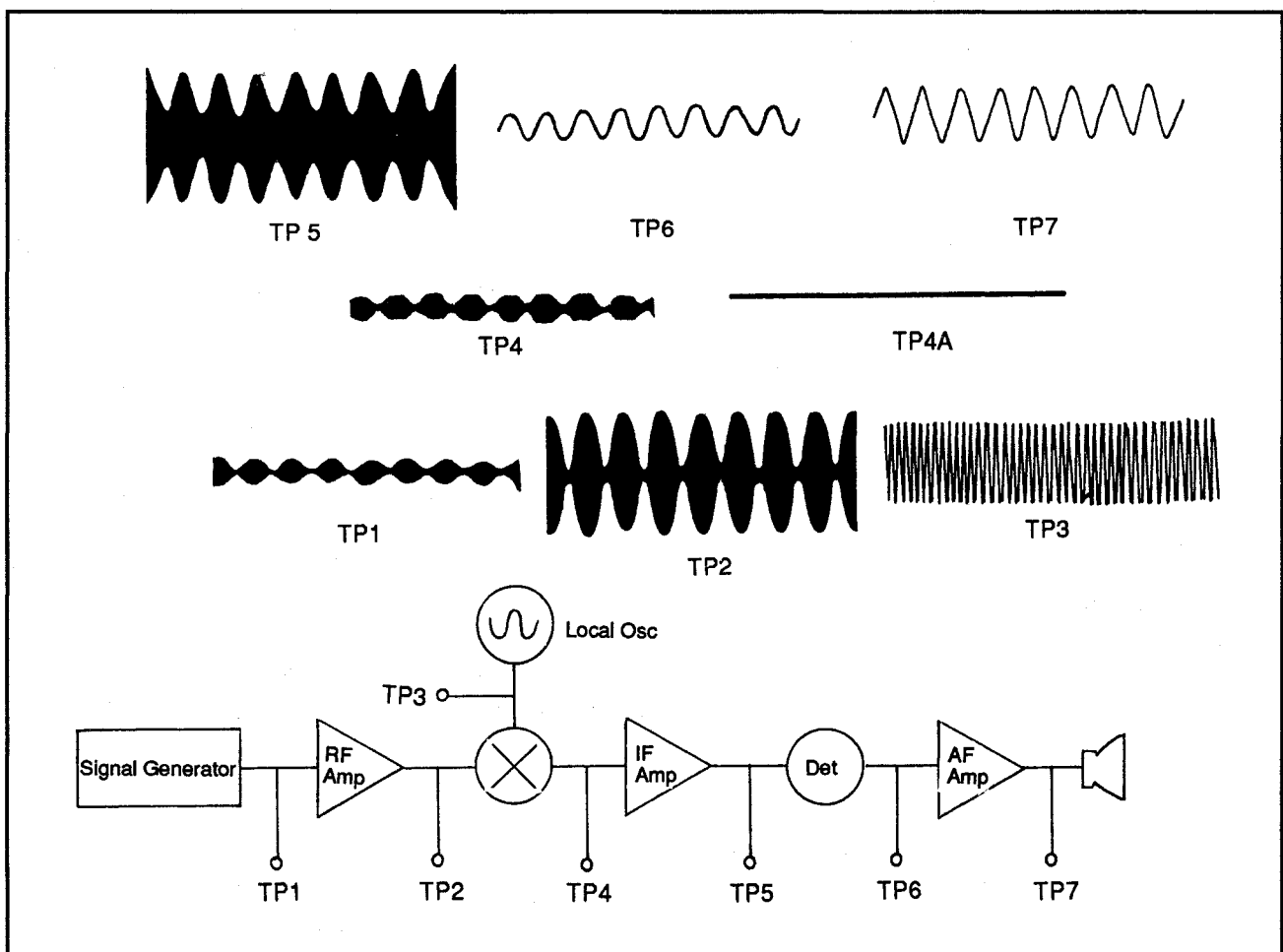
Signal tracing is the best method for detecting problems in transmitters, and in solid-state and high impedance circuits. Signal tracing transmitter circuits by diagram blocks is the best way because the necessary signals are present by design. Most signal generators cannot supply the wide range of signal levels required to test a transmitter, so the internal signals should be present.

A steady signal must be present in the circuit passband for signal tracing. An off-air signal can be used when checking receivers.

The best signal tracer is an oscilloscope. It offers high input impedance, variable sensitivity, and a constant display of the traced waveform. By using a demodulator probe you can view the modulation envelope in RF circuits. By using the inputs of a Dual-trace scope, you can view both the input and output of a circuit simultaneously.

The signal source should be set to an appropriate level and frequency. The test circuit should be turned on and the signal source output connected to the test circuit input.

Place the tracer probe at the circuit input and check to see if a signal is present. If using a scope, observe the characteristics of the signal. Move the tracer probe to the output of the next stage and observe the output.



**Figure 1:** Signal tracing in a simple receiver



Signal levels should increase in amplifier stages and may decrease slightly in other circuits. There will be no signal output for a dead circuit. Various test points and signals found in a simple receiver are shown in Figure 1.

### Signal Injection

Signal injection is more useful in some instances than signal tracing. When troubleshooting a receiver, signal injection is the better choice. A detector is already provided as part of a receiver design.

Signal injection is the better choice for vacuum tube circuits as well. Signal injection may need to be used in low impedance circuits since such circuits may not be able to produce enough signal to drive a signal tracer.

Some kind of detector circuit is required to do signal injection testing. If the circuit under test does not have a detector circuit, one must be provided. Any instrument used for signal tracing will act well as a detector circuit (remember to consider the input signal when choosing a detector).

The signal injector must be able to supply appropriate frequencies and levels for each stage to be tested. For example, in a typical superheterodyne receiver there must be AF, IF and RF signals that vary from 6 V at AF to .2  $\mu$ V at RF. Each conversion stage requires different IF from the signal source.

Test your detector first to be sure that you can pick up the signal you are looking for. It would be a waste to try signal injecting if the detector not working. Work backward from the detector circuit and inject the appropriate signal.

Continue moving to each stage input until the signal disappears. The point where the signal disappears will tell which stage is bad. Remember, the signal level injected will decrease as you digress toward the RF input. Also use suitable frequencies for each stage tested.

Mixer stages present a problem because they have two inputs: one from the RF circuit and one from the local oscillator. Either input could be the result of a problem at the detector stage. The oscillator should be checked with a scope to detect if signal oscillation is present.

Replacing a dead oscillator can clear many problems. An oscillator that is operating improperly can cause miscellaneous errors. Signal injection is not adequate to test the oscillator input to the mixer because of the many frequencies that are created simultaneously. A well shielded signal generator must be set at the level of the LO (local oscillator) frequency to ensure an accurate signal for testing.

**7/R**  
Radio

7/R - TR

Troubleshooting And Repair

7/R - TR - CT

Circuit Tests

**Quick Checking**

Stepping through stage by stage is not always necessary. Random checking works well, too. Instead of checking 1, then 2, then 3, etc., you might try the divide and conquer method. Check at the halfway point first. If this shows a problem, advance halfway away from the detector to see if the problem is there. If the signal was not found at the halfway point, advance halfway closer to the detector. By advancing to half the distance checked previously one can quickly locate a problem.

**7/R**  
Radio

7/R - TR

Troubleshooting and Repair

7/R - TR - DTR

Digitally Tuned Radios

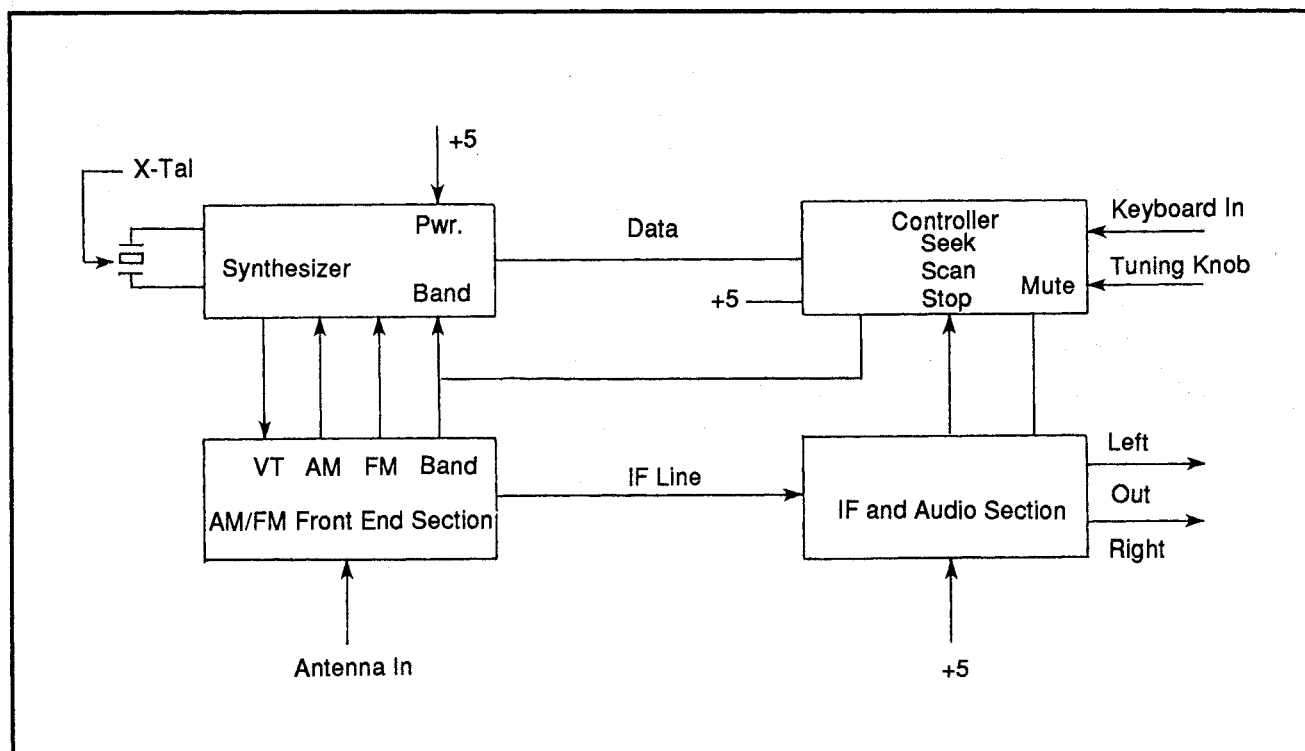
**7/R - TR**  
**Troubleshooting and Repair**

**7/R - TR - DTR**  
**Digitally Tuned Radios**

**Introduction**

The newest radios use digital tuning which offers the advantage of drift-free reception. Other advantages include station presets and signal-seeking tuning capability. Most often these are found in automobiles which are a good example of synthesizer radios using presets. Simply push a button and the station is recalled from memory.

A typical AM/FM stereo synthesized receiver is shown in Figure 1. The receiving end of these radios still use the superheterodyne circuitry with some modifications. Instead of using the old mechanical tuning capacitor, a set of varactor



**Figure 1:** A digitally tuned radio

# 7/R Radio

7/R - TR

Troubleshooting and Repair

7/R - TR - DTR

Digitally Tuned Radios

diodes control the tuning frequency. Varactors change their capacitance in direct proportion to the driving voltage.

## Synthesizer

The synthesizer monitors the AM or FM local oscillator and varies the tuning voltage that drives the varactor diodes which control the receiver frequency.

## Input Keypad

Digitally tuned receivers can use an input keypad which may be on the front panel or a remote and allow for the use of presets, AM/FM selections with seek-and-scan as well as other input selections. This control section tells the synthesizer what to do in relation to radio reception.

## Power Supply

The power of a digitally-tuned radio usually has an input voltage regulated to 5V. There is also a memory battery or charged capacitor back-up to retain stored information in the event of power loss.

## Signals

The synthesizer works closely with the AM and FM and local oscillator signals from the front end (receiving section for the AM and FM signals). After the synthesizer receives a divided-down signal from an AM or FM local oscillator, a phase detector compares it with a signal derived from a crystal oscillator whose frequency is typically at 10 kHz.

## Output

The output is an analog tuning voltage that varies with the difference between the local oscillator and the crystal oscillator frequencies. The tuning voltage is adjusted to equilibrium when the two frequencies are matched and the desired frequency is tuned in. This is when the signal is locked in.

FM signals must be sent to a prescaler IC to divide the frequencies to a level the synthesizer can handle. AM signals can be handled without the need for prescaling.

## Voltage

The tuning voltage for an AM signal is usually between 1.5 V (540 kHz) to 6.9 V (1600 kHz) in car radios, and may be from 3.0 to 21 V in home receivers. FM voltages are slightly lower than the AM tuning voltages.

## Test Procedures

The best method for fixing a digitally tuned radio is to replace it.

However, there are some test procedures that can be done without having factory training and complete service information (although service literature is helpful).

# 7/R

## Radio

7/R - TR	Troubleshooting and Repair
7/R - TR - DTR	Digitally Tuned Radios

Before digging into a receiver that seems to be malfunctioning, check all the functions first. See what works and what does not work. Then move inside and look for the obvious: blown fuses, broken or shorted wires and components, solder joints either cold or broken, etc. The problem may be as simple as a stuck keyboard (control panel) that needs a good cleaning to return the unit to operation.

The advantage of a digitally tuned radio is the limited number of ICs needed to make it work. This makes for easy troubleshooting. Also there is little that should go wrong. However, even the simplest electronic components sometimes go bad.

### AM/FM Tuner

The AM and FM tuners of a digitally controlled tuner are most likely be in one IC. The AM/FM front end is good if you hear a rushing sound with the volume turned up. Verifying this can be accomplished by hooking an antenna up and listening for a station near 540 kHz for AM and 88.1 MHz for FM.

### Controller

The controller of a digitally controlled tuner is either a keypad, a series of buttons on the front panel, or a remote control to change functions. Test the operation of all the key functions. If they work on the front panel, the IC controller is probably good. If one or more key functions are bad while others still work, the problem is most likely the keypad and not the IC controller. Shorting the key contacts for the bad key can confirm this.

### Display

Displays of most digitally-controlled units are either LCDs or LED. Missed segments in the display probably mean there is an open connection between the display and driver. Look for, or resolder, bad connections or broken wires.

Replacement of the display generally means a complete replacement of the entire unit.

### Synthesizer

The synthesizer is good if you can tune an AM or FM station. If you can't get an FM station (but can get an AM station), the problem is in the prescaler and not the synthesizer. If you can't get an AM station, check the local oscillator for output, or check the synthesizer IC itself.

### Prescaler

Prescalers divide the FM local-oscillator signal by a preset value (15 or 16) and output this signal to the synthesizer for processing. Prescalers have simple checks. Either they work or they don't. An absent FM signal means the prescaler is bad and needs to be replaced.

**7/R**  
**Radio**

---

7/R - TR

Troubleshooting and Repair

---

7/R - TR - DTR

Digitally Tuned Radios

---

**Loop Filter**

The output from the synthesizer must be filtered, and possibly scaled to suit the AM/FM front end which is done by a loop filter. The filtering system is simply a low-pass filter that removes noise pulses created by the phase detector to create a clean DC output.

Testing the function of a loop filter is easy. If you can tune the entire AM band without a whine in the sound, the loop filter is working properly.

**Power Supply**

The power supply of a digitally controlled tuner with problems will cause no display, and nothing else will happen. Test the power section, or substitute it to see if operation returns.

# 7/R

## Radio

7/R - TR

Troubleshooting and Repair

7/R - TR - R

Receivers

## 7/R - TR

### Troubleshooting and Repair

## 7/R - TR - R

### Receivers

Receivers are those devices that pick-up radio signals, process them and output them in audio format or signal to be passed to another device. Receivers are used in home stereos, automobiles, citizen band (CB) transceivers, ham transceivers, marine transceivers and more. Most are very similar in operation and require the same basic approach to troubleshooting and repairing.

#### Local Oscillator Checking

A DMM is all that is needed to check the local oscillator of a receiver. The oscillator generates its own signal, so a test signal is not required. The connection for testing an oscillator of a transistor-based circuit is shown in Figure 1.

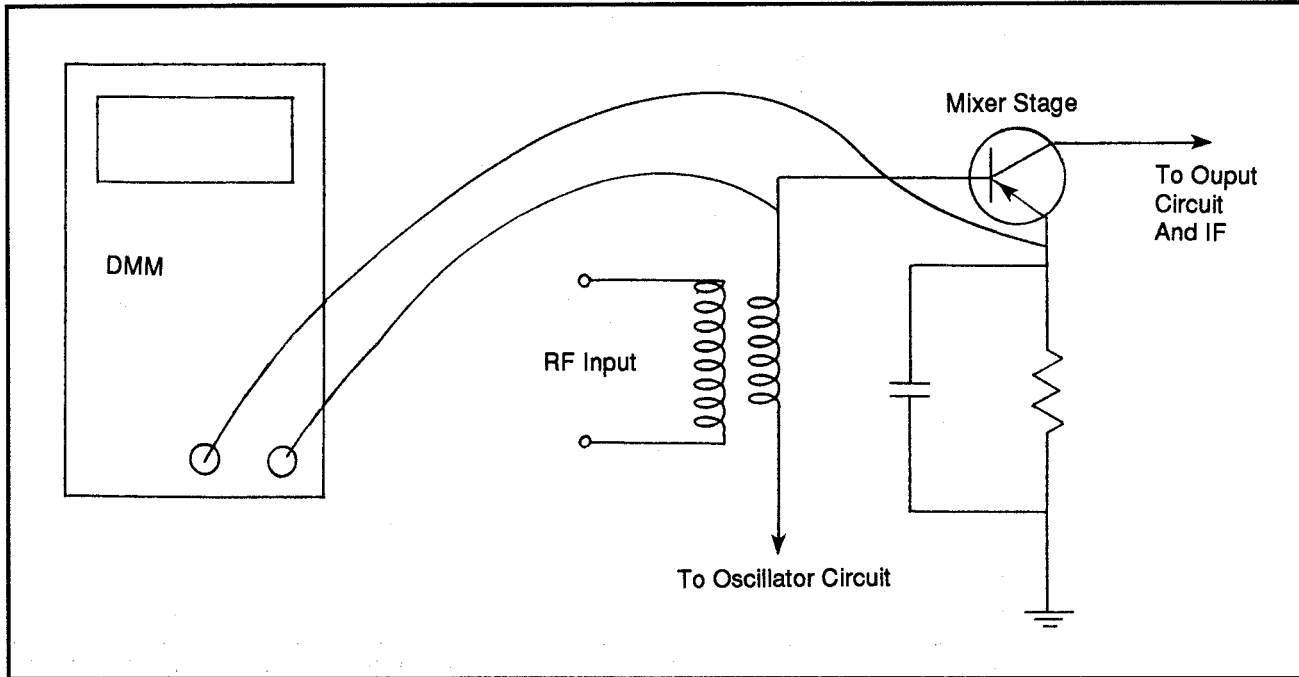
The meter is connected between the emitter and the base of the circuit's transistor under test. You are looking for a reading of any kind. The value is not important, but it will be very low (only a few tenths of a volt). If the voltage is fixed, the oscillator is not operating. If it changes a few tenths of a volt as you tune, the oscillator is operating normally.

#### IF Amplifier Oscillation Tests

Possible symptoms of IF amplifier malfunction include a noticeable distortion in the receiver's audio output signal (especially when tuned to a weak station). In severe cases there may be a high squeal or no output signal. A DC voltmeter is used across the load resistor of the receiver's second detector.

If the receiver is not operating and you read a high DC voltage across the resistor, you can be sure there is an oscillating IF amplifier. When the receiver is operating, but has a distorted audio output, refer to the service manual or make a comparison check with a properly operating receiver of the same type and model. If the IF amp is oscillating, find a higher DC voltage at the detector output.

To make an absolute check, you measure the bandwidth of the suspected IF amplifier. If the receiver oscillates with the AGC clamp voltage removed, but stops with the clamp voltage connected, there is probably an open bypass capacitor on the AGC line. Another method for checking an IF amplifier is by



**Figure 1:** Transistor-based oscillator test hook-up

using an RF signal generator, a jumper lead and a variable trimmer capacitor (10 to 350 pF).

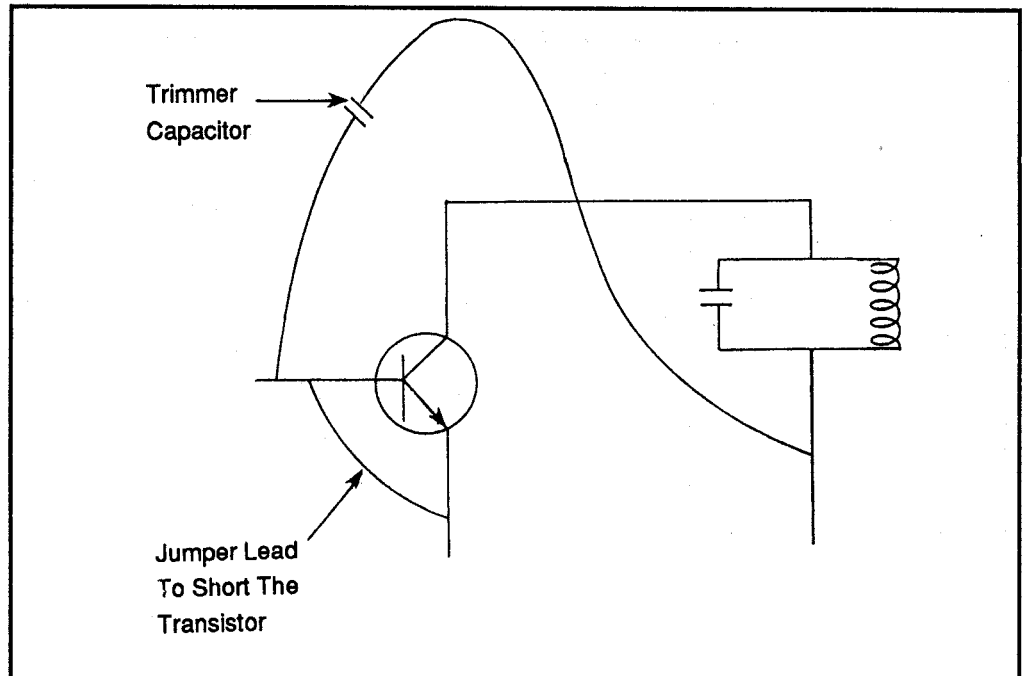
The signal generator is connected to the receiver antenna by using a few turns of wire. The signal generator should be set for about 1 MHz. Turn on the signal generator and the receiver. Adjust the receiver volume control to a tolerable level. If the IF amplifier is operating, you should hear a squeal from the receiver. If this doesn't happen, the problem may be deeper. Take the test jumper lead and short out the suspect IF transistor between its emitter and base. This cuts the transistor off by killing the forward bias. Connect the variable capacitor from the bottom of the IF amplifier output transformer to the base. These connections are shown in Figure 2.

The trimmer cap should be adjusted until you have minimum sound. If you can reduce the sound to little or none, it indicates that the IF amplifier was oscillating. This means that the neutralizing capacitor is possibly open. In this case, replace the capacitor and see if the problem is fixed.

### Automatic Gain Control Tests

Connect the DMM between the AGC line and the chassis ground (or the negative supply). The AGC is a self-acting device that maintains the output of a radio





**Figure 2:** Connection of a jumper lead and trimmer capacitor for an IF amplifier oscillation test

receiver or amplifier at a substantially constant level (within a relatively narrow limit) while the input voltage varies over a wide range. Common AGC problems cause distortion on strong stations. (This circuit is the same as an automatic volume control circuit.)

Use the DMM in the highest DC range. For those units with a switch for turning on/off the AGC, set the switch on. Monitor the DMM and tune the receiver to various stations.

As the signal increases in strength, the gain of the controlled stage is reduced by the increasing value of bias. There should be a change in the DC voltage readings as the receiver is tuned from station to station. Also, the filter capacitor will open, causing the AGC bias voltage to follow the rise and fall of the audio envelope, and may be heard as distortion in the receiver output.

### AM Receiver Tracking Test

AM receiver tracking is the ability to track when a receiver maintains a constant frequency difference throughout the receiver tuning range. Different stations vary and it is impossible to receive all with equal sensitivity. The receiver works at optimum performance when the tuning circuits track as closely as possible.

A dummy load antenna (where applicable) should be connected with a signal generator to the receiver antenna. The receiver should be set to the high end of the dial (around 1400 to 1600 kHz). The use of a fluorescent light produces static across the entire band and can be picked up no matter where you tune the dial. Maximum static should be obtained for this adjustment.

Using a weak test signal (like the fluorescent light near the receiver), adjust the oscillator, RF and antenna trimmers for the maximum output. The oscillator is usually in parallel with the oscillator tank, and the antenna trimmer in parallel with the tuned input circuit.

Tune the signal generator to 600 kHz and tune the receiver for a maximum output. Adjust the signal generator to create a weak signal level output and tune the antenna and RF slugs for maximum receiver output. Several times over are the best adjustment for optimum performance.

A quick tracking check can be done by setting the receiver to some weak station at around 600 kHz and a maximum volume. Adjust the oscillator trimmer for a maximum signal level. Next, set the receiver to a weak station somewhere in the high end of the band. The antenna trimmer should be adjusted for a maximum signal. This should be done several times. If this does not work, follow the procedure in the previous paragraphs for the tracking tests.

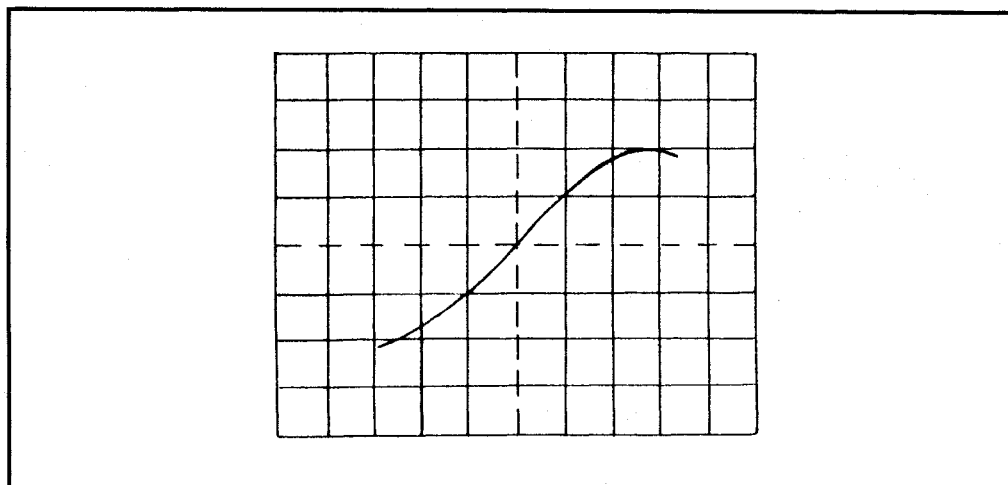
### **FM Demodulator Test**

Checking FM demodulation circuits requires the use of a sweep generator and oscilloscope. The scope should be hooked across the volume control and the sweep generator signal should be interjected into the limiter when the receiver uses a discriminator, or into the last IF amplifier if it has a ratio detector.

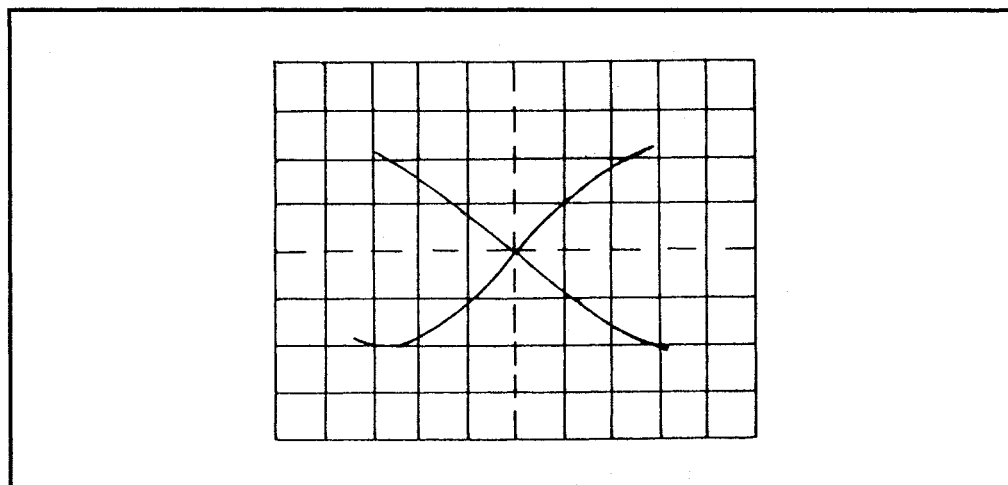
Set the sweep generator to the receiver IF (most will be 10.7 MHz and a bandpass of 200 kHz). Check the specifications from the service manual to be sure. Disable the local oscillator by placing a jumper wire across the oscillator coil. The scope sweep should be set to 60 Hz and the sweep generator to sweep 200 kHz.

Adjust the demodulator by tuning the slug in the transformer secondary unit until the curve is equally divided on both sides of the vertical line. Adjust the primary slug until you achieve an S-shaped curve at about a 45° angle. An example of this wave is shown in Figure 3.

Adjust the horizontal sweep to 120 Hz of the scope and you should see a pattern like that of Figure 4. Next, adjust the secondary coil slug until the two crosses form a near perfect X pattern. This indicates that the demodulator is operating properly.



**Figure 3:** An example curve seen when checking FM demodulation



**Figure 4:** An example curve seen when checking FM demodulation at sweep of 120 Hz

**IF Amplifier Check** This check is an IF alignment check. Use a sweep generator connected to the first IF amplifier input circuit as shown in Figure 5. The receiver oscillator should be shorted by placing a jumper across the oscillator wire. Set the sweep generator to the IF frequency (10.7 MHz, normally).

Next, set the sweep generator to the correct sweep frequency. This can be anywhere from 50 kHz to as high as 250 kHz. This information will have to come from the service manual. Cheap receivers will be near 50 kHz and very expensive receivers from 150 to 250 kHz.

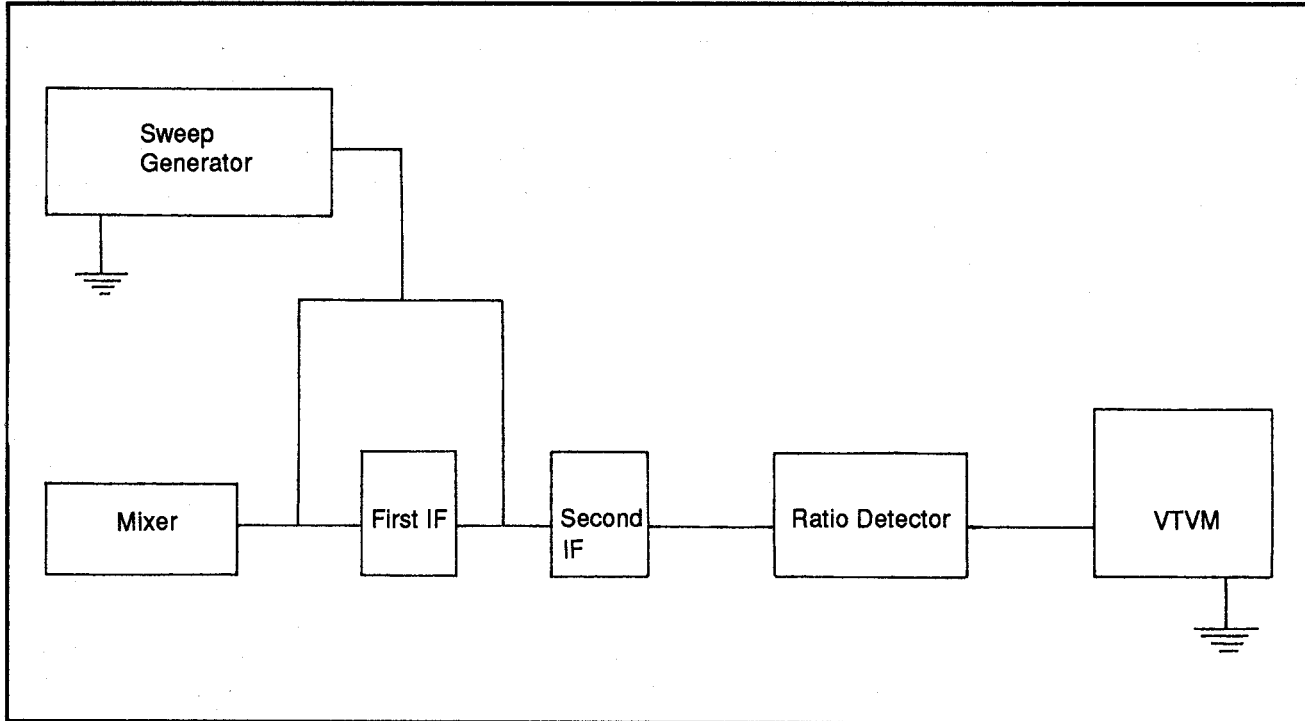


Figure 5: IF amplifier test for FM radio with ratio detector circuit

Connect the DMM across one side of the ratio detector. The output can be negative or positive (it doesn't matter which it is). Check each IF amplifier and adjust for the highest possible reading. A more sophisticated alignment is needed if you see a decent signal strength reading during this test.

### Stereo Amplifier Power Output Check

Both channels' gain controls should be set for the same level. Measure the AC volts (rms) developed across each speaker voice coil with an identical signal input. This can be done with a DMM, or with a dual-trace scope which allows you to view both channels at the same time. The scope will be giving a peak-to-peak reading which must be converted to rms voltage by dividing the peak-to-peak by 2.8 before proceeding. Compute the output for each channel by the formula:

$$P = \frac{E^2}{R}$$

where R is the speaker impedance. Check the waveforms of each channel for distortion by using the scope and an identical signal sent to both channels.

**7/R**  
Radio

7/R - TR

Troubleshooting and Repair

7/R - TR - R

Receivers

**Phase Lock-Loop  
(PLL) FM Stereo  
Demodulation**

Many newer receivers use PLL FM stereo demodulators. These ICs require no inductors, have no oscillator adjustments and a low external part count. These can be adjusted by using the receiver alone. No other test equipment is necessary.

Tune the receiver to a stereo broadcast and adjust a variable resistor until a pilot light/LED turns on. To find the center point where the signal is locked on, rotate the potentiometer back and forth until the lamp/LED center is on. The results should be within a few dB.

**7/R**  
**Radio**

---

7/R - TR

Troubleshooting and Repair

---

7/R - TR - R

Receivers

---

## 7/R - TR

### Troubleshooting and Repair

## 7/R - TR - T

### Transceivers

#### Switching Control Problems

Transceivers use elaborate switching schemes for signal control. Many of the problems within a transceiver can be traced to relay or switching problems. A switching control problem could occur when:

- The S meter is inoperative.
- There is arcing in the tank circuit.
- Received signals are erratic or weak.
- There is PA noise in the receiver.
- The plate current is high during reception.

Some transceiver circuits are shared, and stage defects frequently affect both the receive and transmit modes.

These symptoms may vary depending on the mode selected.

#### Oscillator Problems

Oscillator problems usually affect both modes, but different oscillators or frequencies may be used for different emissions. Refer to the block diagram in the service manual.

#### VOX Control

Another potential trouble area is VOX control. The VOX-sensitivity and anti-VOX control settings should be checked if there is difficulty in VOX control.

#### PTT and MOX

Next, make sure the PTT and manual (MOX) transmitter controls are functioning. If these controls work, the VOX-control diodes and amplifiers should be checked. All switches, control lines and control voltages should be tested if the transmitter does not respond to other transmit controls.

VOX-sensitivity and anti-VOX settings should be checked if the transmitter switches are on in response to received audio. Check the related circuits next. A poor VOX delay adjustment will cause unacceptable VOX timing results. A bad resistor or capacitor in the timing circuits or VOX amplifiers could be at fault.

**7/R**  
**Radio**

7/R - TR	Troubleshooting and Repair
7/R - TR - T	Transceivers

**Aligning  
Transceivers**

Do not attempt to align a transceiver without the service manual. The mixing schemes of the modern SSB transceiver are very complicated. The signal passes through many mixers, oscillators and filters. Satisfactory SSB communication requires that each stage be accurately adjusted.



**7/R**  
Receiver

7/R - VCS

Various Case Studies

7/R - VCS - Tech ST-S8

Technics ST-S8

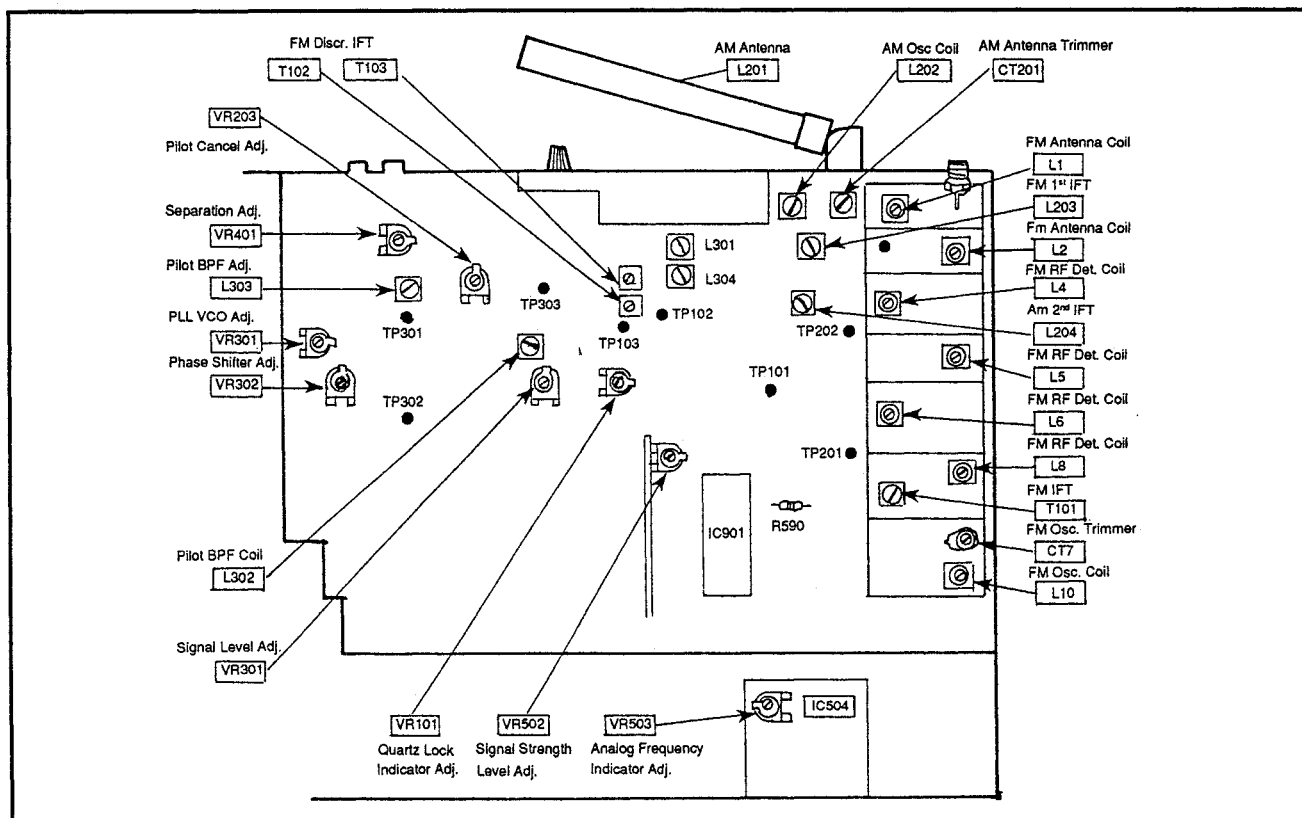
**7/R - VCS**  
Various Case Studies

**7/R - VCS - Tech ST-S8**  
Technics ST-S8

**Introduction**

The ST-S8 is a compact AM/FM unit designed for reception and play of the standard radio broadcasts in both monaural and stereo. The unit is relatively simple in design and uses a central 1704 IC to handle much of the processing and control.

The various test and adjustment points are shown in Figure 1. It's important to note that L301 and L304 have been critically set in manufacture. These should not be touched or adjusted.



**Figure 1: Test and adjustment points**

# 7/R

## Receiver

7/R - VCS

Various Case Studies

7/R - VCS - Tech ST-S8

Technics ST-S8

### AM Adjustments

To make all adjustments to the AM sections you need a voltmeter (preferably a DMM) capable of measuring both AC and DC, an AM signal generator and a non-metal screwdriver for making adjustments to various components. (A metal screwdriver will change the characteristics of the adjustable component. This is particularly true with coils.) The frequency used with the generator will change, but in all cases use a 30% modulation with 400 Hz. The generator output should be as low as possible while still providing the necessary readings.

Set the Technics' selector to the AM position and the FM/AM allocation selector to the 0.2 MHz/10 kHz position. Place the antenna coil at a 25 degree angle away from the back panel. Connect the AM signal generator to the antenna terminal through a 200 pF capacitor, and with the common going to the chassis ground. You are now ready to make adjustments to the AM sections of the unit.

### AM IF Adjustment

Set the AM signal generator to 450 kHz. Set the DMM to read volts AC and connect it to the output terminals. (As an option you can use an oscilloscope hooked to the output terminals.)

L203 is the first IFT; L204 is the second IFT. Adjust these so that output voltage is maximum.

### AM RF Adjustment

With the AM signal generator connected as above, set it for a frequency output of 530 kHz. This should show on the set's display. Set the DMM to read DC volts and connect it to TP201. Adjust L202 (the oscillator coil) so that the reading is  $1\text{ V} \pm 0.05\text{ V}$ .

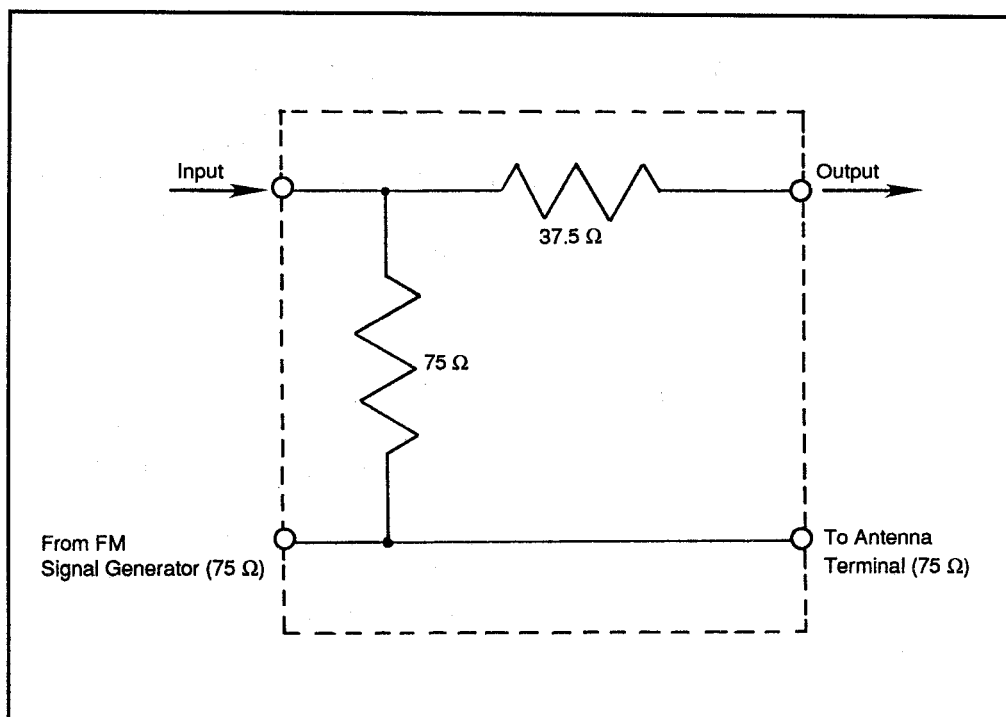
Readjust the signal generator to 610 kHz, and verify that the display shows this frequency. Set the DMM to read AC volts and connect it to the output terminals of the unit (in back). Adjust L201 (the antenna coil) for maximum output.

Finally, reset the generator to provide a frequency of 1500 kHz, and again verify this on the display. Leave the DMM set for AC volts and connected to the outputs. Adjust CT201 (the antenna trimmer) for maximum level output.

It's a good idea to repeat the last two steps at least twice to be sure that everything is fine-tuned. This is especially important if the frequency shown on the display wasn't correct.

### FM Adjustments

As is always the case, the FM sections tend to be more complex and thus require a larger number of adjustments. To make these adjustments a voltmeter capable of reading AC and DC volts is required. Other equipment needed is an



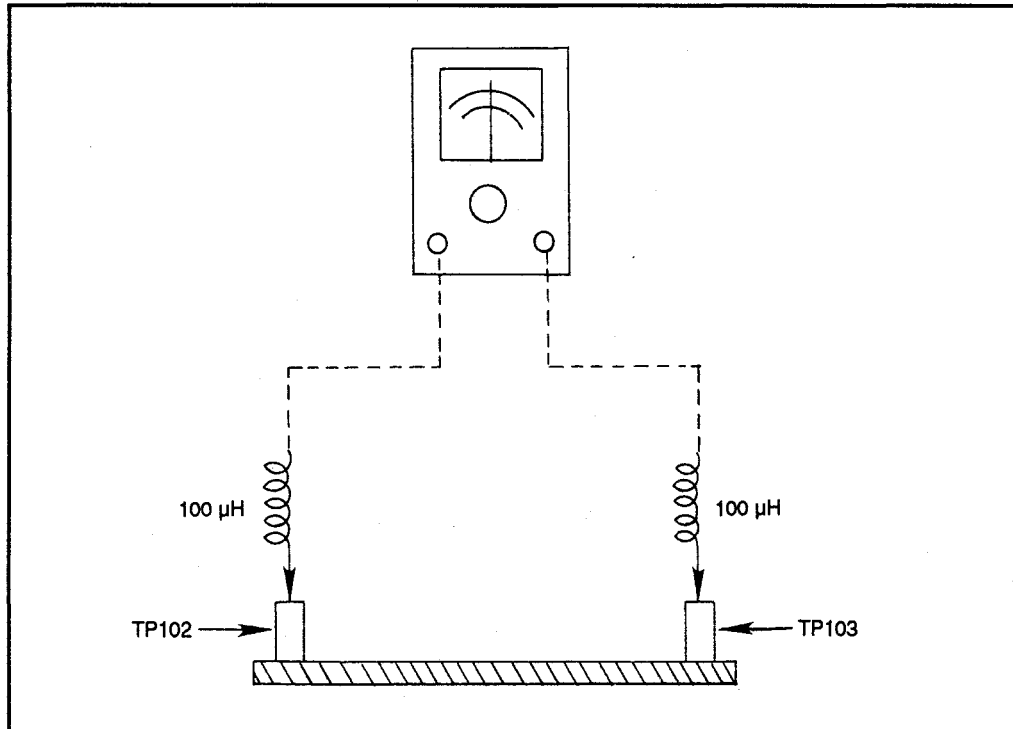
**Figure 2:** A 75  $\Omega$  FM dummy antenna

oscilloscope, a distortion analyzer and a frequency counter with a range of at least 19 kHz to 108 MHz.

The FM signal generator used should provide 100% modulation with 400 Hz at the various frequency settings, except where specifically noted (when nonmodulation is required to make an accurate test). The generator's output should be 72 dB. This is to provide an actual input of 60 dB (1 mV) through the FM dummy antenna shown in Figure 2.

The signal generator is connected to the unit at the FM antenna terminals. To do this a dummy antenna is needed. You can easily build the device yourself. All you need are two resistors (37.5  $\Omega$  and 75  $\Omega$ ) and a little wire. It is easier if you install clips on the ends.

Before beginning, place the FM IF band switch to the "normal" position, the FM mode switch to the "auto" position, the display switch to the "signal" position, and the FM muting switch to "off". Place the FM tuning level switch to the "standard" position and the FM/AM selector to the FM position.



**Figure 3:** Connecting the DMM to TP102 and TP103

**FM IF Adjustment** With no signal input, set the display to read 100.1 MHz. Set the DMM to read DC volts. Attach a 100  $\mu$ H choke coil to each of the DMM's probes, and these in turn to TP102 and TP103 (as shown in Figure 3).

Adjust the discriminator IFT, T102, so that the voltage reading is 0 V in the 300 mV range.

**FM RF Adjustment** Begin with no signal input and the DMM set to read DC volts. Connect the DMM to TP1. Adjust L10 (the oscillator coil) until the voltage reads to within 0.1 V of 4.1 VDC.

Now connect the FM signal generator through the 75  $\Omega$  dummy antenna as explained above. Set the generator to supply a 90.1 MHz signal, and check the display to verify that it shows this reading. Connect the oscilloscope to the set's output terminals.

Adjust L4, L5, L6 and L8 (all of which are FM RF detector coils), L1 and L2 (the FM antenna coils) and T101 (the FM IFT).

# 7/R

## Receiver

7/R - VCS

Various Case Studies

7/R - VCS - Tech ST-S8

Technics ST-S8

Add a weak input so that noise is introduced in the output waveform, as shown in Figure 4. Adjust the coils and IFT until the output waveform is vertically symmetrical.

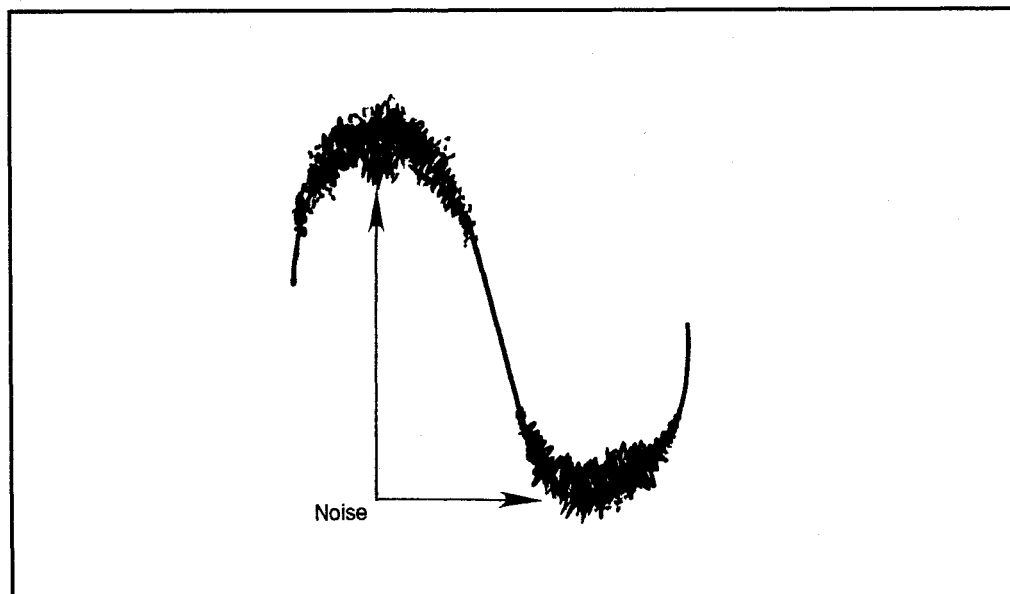
Change the signal generator frequency to 106.1 MHz. Adjust CT7, the FM oscillator trimmer, again with the goal being a symmetrical waveform.

Repeat the last two steps until the waveform is correct and until the dial display indicates the input frequency. Then return to the adjustment on the L10 oscillator coil to be sure that the results for this step haven't changed. If they have, readjust L10, repeat the coil and trimmer adjustments and recheck L10. Repeat this sequence until the readings are exactly correct.

### FM Mono Distortion Adjustment

With the FM signal generator connected as above (through the dummy antenna), set the output for 100.1 MHz. Connect the distortion analyzer to the unit's output terminals.

Adjust T103 to minimize the distortion on both the left and right channels. Return to the test above concerning T102 and check the deflection. If need be, readjust T102. (You may also have to repeat the RF coil and trimmer adjustments but this is relatively rare.)



**Figure 4:** Noise in the waveform

**7/R****Receiver**

---

7/R - VCS

---

Various Case Studies

7/R - VCS - Tech ST-S8

---

Technics ST-S8

---

**FM Multiplex Pilot (VCO) Adjustment**

With the FM signal generator connected to the antenna terminals through the dummy antenna, insert an unmodulated 100.1 MHz signal into the system. Connect a frequency counter to TP302. Adjust VR301 (the pilot or VCO) to get a reading on the frequency counter of 19 MHz  $\pm$  30 Hz.

**Pilot Bandpass Filter Adjustment**

The signal from the FM generator should be at 100.1 and unmodulated. Set the DMM to read AC volts and connect it to TP301. The two bandpass filters are L302 and L303. Adjust these so that the voltage is maximum.

**Pilot Cancel Adjustment**

With the generator still at 100.1 MHz and unmodulated, connect an oscilloscope to TP303. Adjust L302 (pilot BPF) and VR303 (pilot cancel adjust) to minimize the voltage and to cause a waveform similar to Figure 5.

**Phase Shifter Adjustment**

For this adjustment the FM signal generator should again be set for 100% modulation with 400 Hz. Set the DMM to read AC volts and connect the probe to the left channel output. Adjust VR302 to bring the left channel output to a maximum level.

**Stereo Distortion Adjustment**

With the signal connected as above, connect the distortion analyzer the left channel output terminal through the lowpass filter. Adjust T101 to be within  $\pm 90^\circ$  of the preset and already adjusted core position, so that the left channel distortion is minimal.

With this completed, go back to the FM IF and RF adjustments given above and repeat the steps.

**Separation Adjustment**

Using the same 100.1 MHz signal, adjust the generator to have 100% modulation with 1 kHz. Set the DMM to AC volts and connect the probe to the output terminals, one at a time, through the lowpass filter.

Adjust the separation at the variable resistor VR401 until the right channel output is minimal while the panel control is in the left channel position, and likewise so that the left channel output is minimal with the control in the right channel position.

**Signal Level Adjustment**

Return the FM signal generator to the 100% with 400 Hz setting (still at a frequency of 100.1 MHz). Reduce the signal strength so that the input level is 50 dB. Turn the variable resistor VR501 in a counterclockwise direction to minimum. Slowly turn the adjusting screw clockwise until the fifth LED comes on.

# 7/R

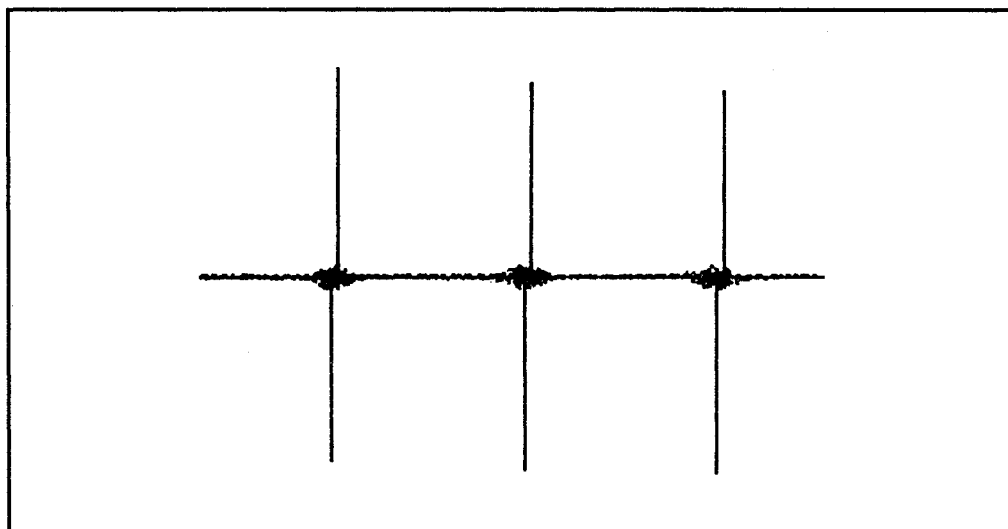
## Receiver

7/R - VCS

Various Case Studies

7/R - VCS - Tech ST-S8

Technics ST-S8



**Figure 5:** Waveform for pilot signal cancel

### Signal Strength Adjustment

Turn on the unit and let it operate for at least one minute to be sure that the power supply is fully warmed and stable.

Increase the signal generator's output to provide 80 dB to the unit. Now push the FM signal button to have the fluorescent display indicate signal strength. Adjust the variable resistor VR502 until the level is shown to be 78 dB.

Reduce the generator's output to a level of 40 dB. Check the unit's indicator. It should show this level within a range of 36-48 dB. If it does not, and particularly if the indication is below 36 dB, cut off R590, located near IC901, and try to readjust VR502.

### Quartz Lock Indicator Adjustment

VR101 is the quartz lock indicator adjustment. With everything connected as before, turn this variable resistor counterclockwise until the quartz lock indicator goes out. Slowly turn the screw clockwise, adjusting it to a point at which the quartz lock indicator lights up.

### Analog Frequency Indicator Adjustment

Change the FM signal generator output frequency to 107.1, and verify that this is shown on the display. Turn VR503 clockwise until the LED 15th from the left goes out. Slowly adjust VR503 until this 15th LED lights up and 14th goes out.

### The ICs

Much of the processing is handled by IC901. This is a 42-pin SVID1704C514 chip. This 1704 chip interconnects with the other circuits and chips. Figure 6 shows the pinout configuration of this IC.

**7/R**  
Receiver

7/R - VCS  
7/R - VCS - Tech ST-S8

Various Case Studies  
Technics ST-S8

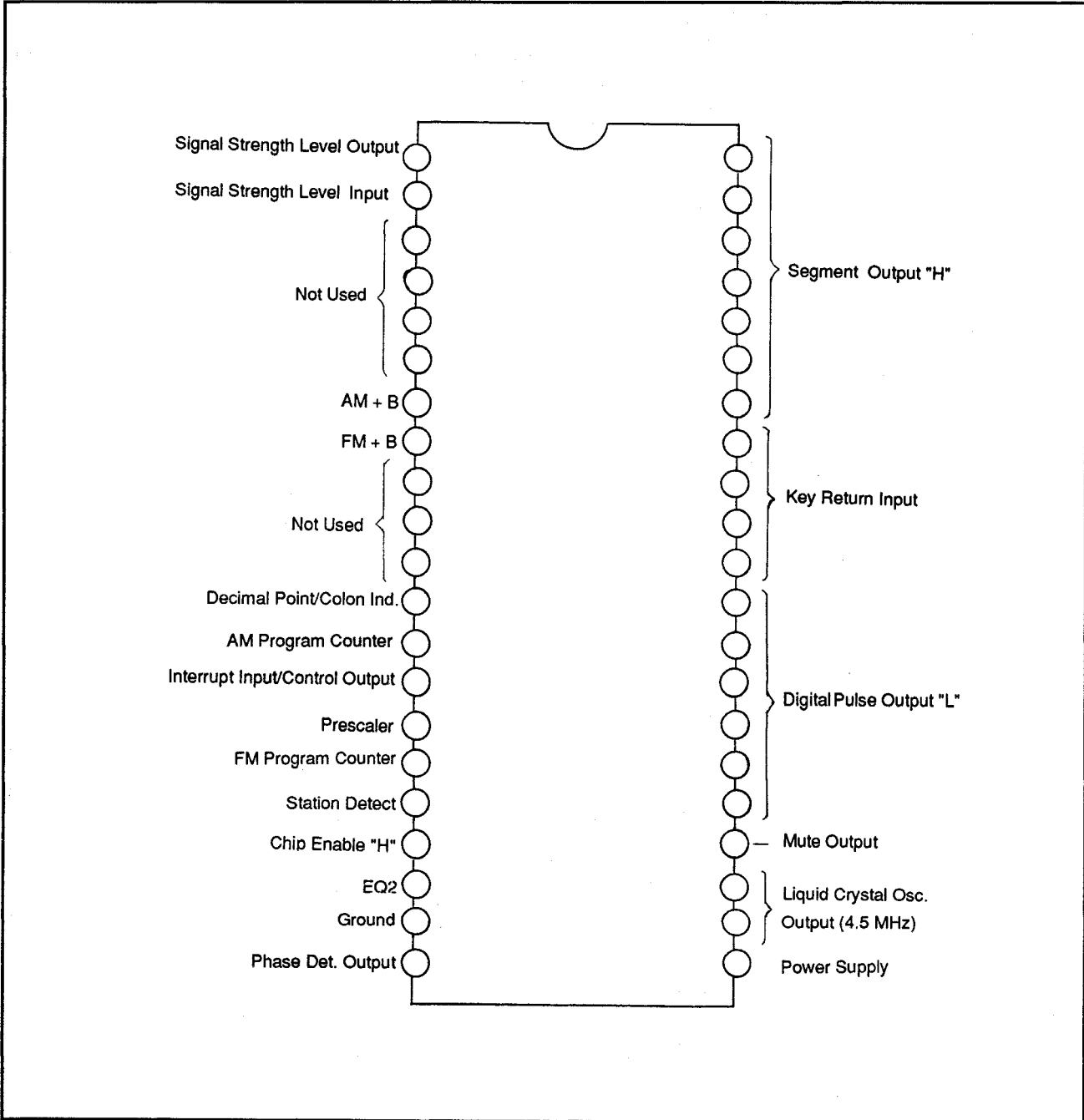


Figure 6: IC901 (SVID1704C514) pinout



# 7/R

## Receiver

7/R - VCS

Various Case Studies

7/R - VCS - Tech ST-S8

Technics ST-S8

### Pin Description Table

Pin	Description
1 - 7	Segment output and key matrix signal "H"
8 - 11	Key return signal input
12 - 17	Digital pulse output "L"
18	Muting output ("L" in normal mode; "H" in tuning or preset mode)
19 - 20	Liquid crystal oscillator input (4.5 MHz)
21	Power supply (4.8 V)
22	Phase detect output
23	Ground
24	EQ2 (0.6 V)
25	Chip enable ("H" at normal; "L" at memory holding)
26	Station detector input ("L" in autoscanning, which activates muting circuit)
27	FM program counter input
28	Prescaler control
29	Interrupt (control) input
30	AM program counter input
31	Decimal point indication output in FM; colon indication output during channel display
32 - 34	Not used
35	FM +B voltage control; "H" in FM, "L" in AM
36	AM +B voltage control; "H" in AM, "L" in FM
37 - 40	Not used
41	Signal strength level input
42	Signal strength level output

The remainder of this section shows you the pinouts and typical voltages you can expect at the pins.

**7/R**  
Receiver

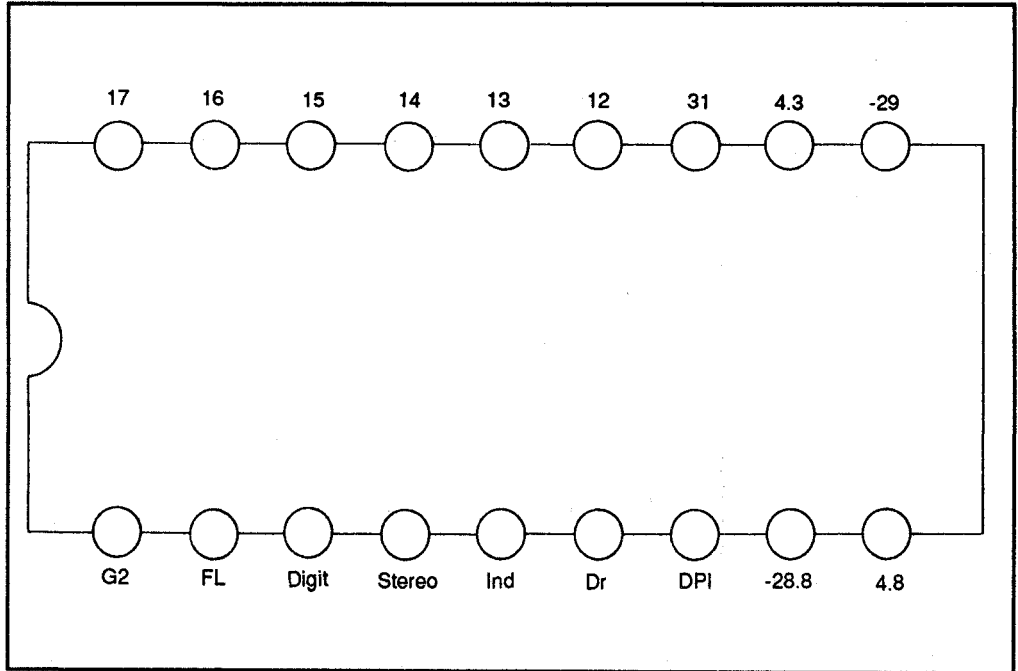
7/R - VCS

Various Case Studies

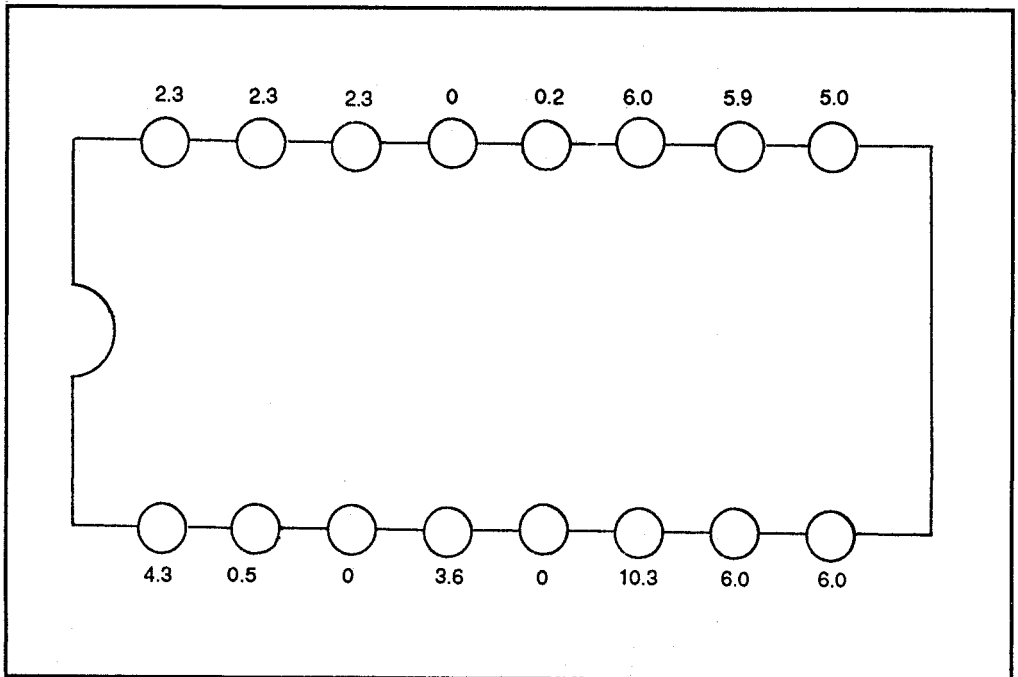
7/R - VCS - Tech ST-S8

Technics ST-S8

**Pin Connections**



IC903 (SVIMSL915RS)



IC104 (SVIPC1167C2) FM IF Detector

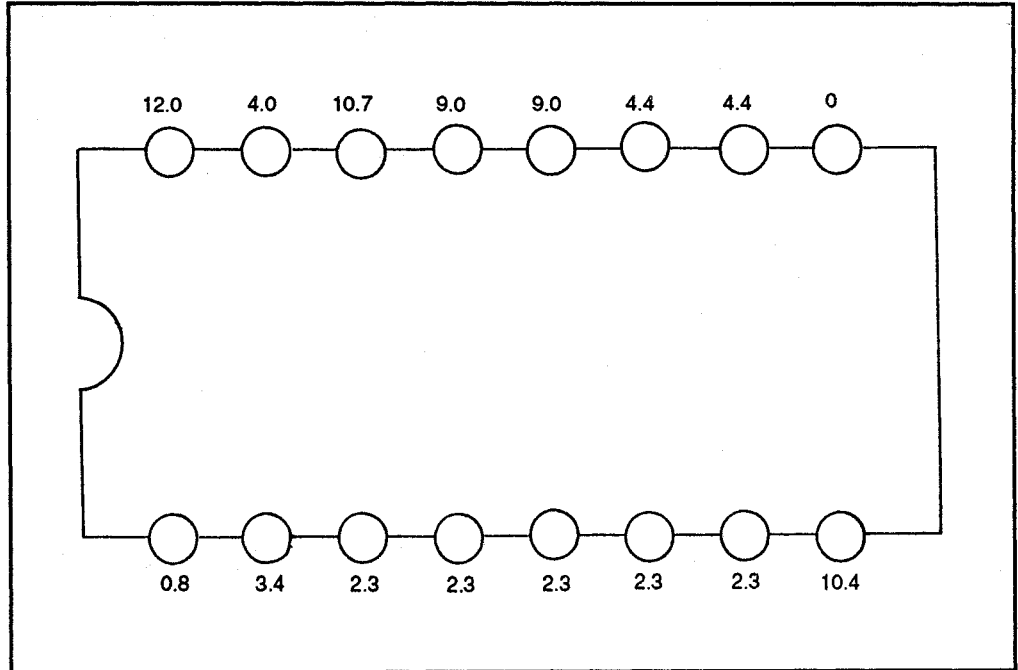
**7/R**  
Receiver

7/R - VCS

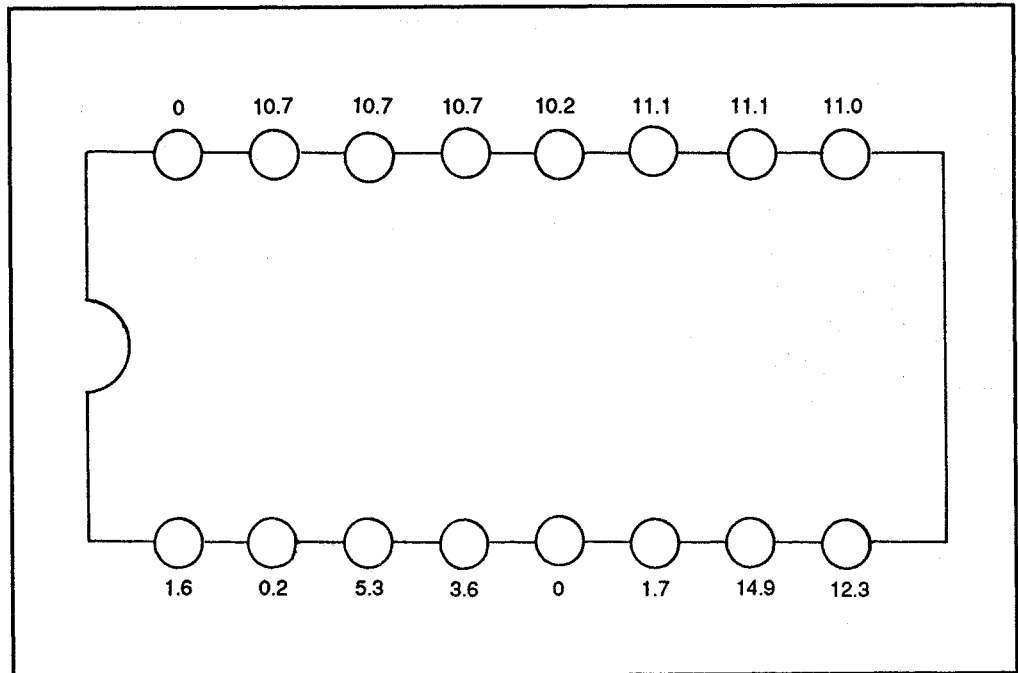
Various Case Studies

7/R - VCS - Tech ST-S8

Technics ST-S8



IC301 (SVIPC1161C) PLL



IC504 (SVIUAA170) LED Driver

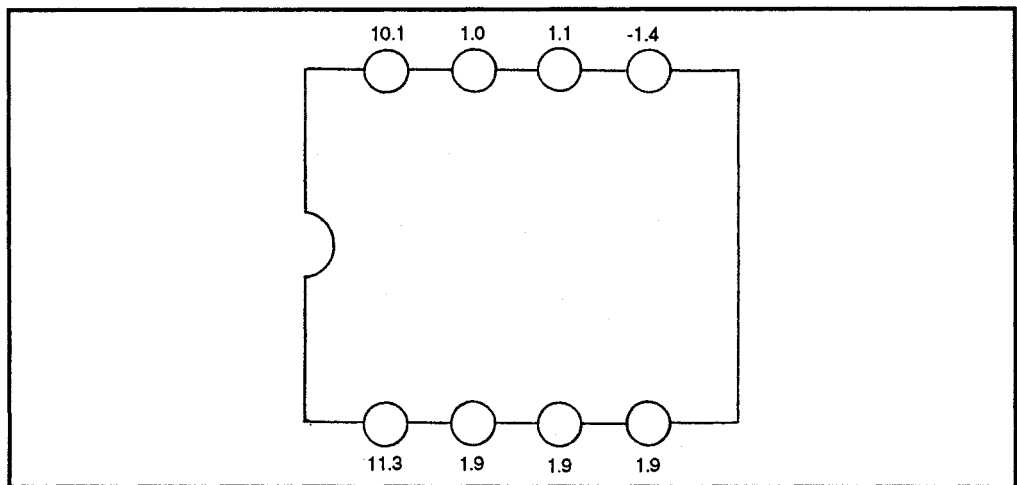
**7/R**  
Receiver

7/R - VCS

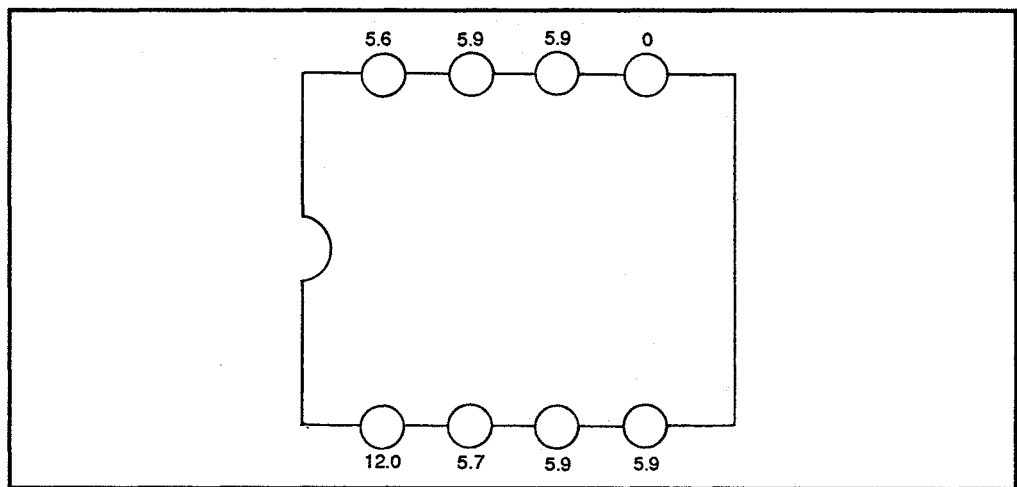
Various Case Studies

7/R - VCS - Tech ST-S8

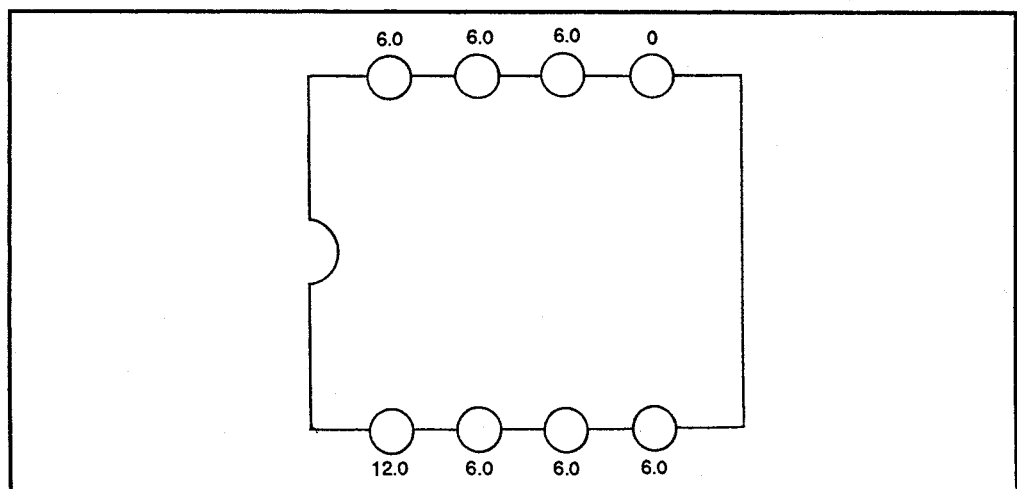
Technics ST-S8



IC302 (AN6552) Multipath Amp



IC401 (AN6552) Buffer Amp



IC503 (AN6552) LPF



7/T - VCS

Various Case Studies

7/T - VCS - ZXP

Zenith XP Tuner

## 7/T - VCS Various Case Studies

## 7/T - VCS - ZXP Zenith XP Tuner

### Introduction

This case study covers troubleshooting and repairing the Zenith IS4090-XP series tuner with built-in tape player/recorder. The information provided can also be applied to the many different makes and models of tuners available.

### Adjustments

As with any receiver, the unit has been factory aligned and should not be adjusted unless a component has been replaced or someone has been tampering with the settings.

Assuming that you use exact replacement parts, alignment should not be necessary even after fairly extensive service and repair. The only exception to this is when one or more of the many coils is replaced. Even then alignment may not be necessary. The trick is to always use exact replacement parts when servicing, especially when the equipment at hand is a receiver.

### General Troubleshooting

The key to general troubleshooting is to determine where the problem is originating. If the FM works and the AM does not, there is a problem in the AM tuner section and not the FM section (this also eliminates the audio output and tape sections). If neither radio section works, or if there is no output at all, the problem does not lie in the AM or FM sections, but is more likely in the audio section.

### RF Checks

Units which have AM and FM are generally easier to troubleshoot for this reason. Quickly test to see if the problem is in an RF section or in an amplifier section. If one of the two bands works, the amplifier section is functional. If neither works, the RF sections are probably fine. Having the built-in tape player/recorder gives you an additional easy step. It is highly unlikely that the tape section will record or play if neither RF section is working.

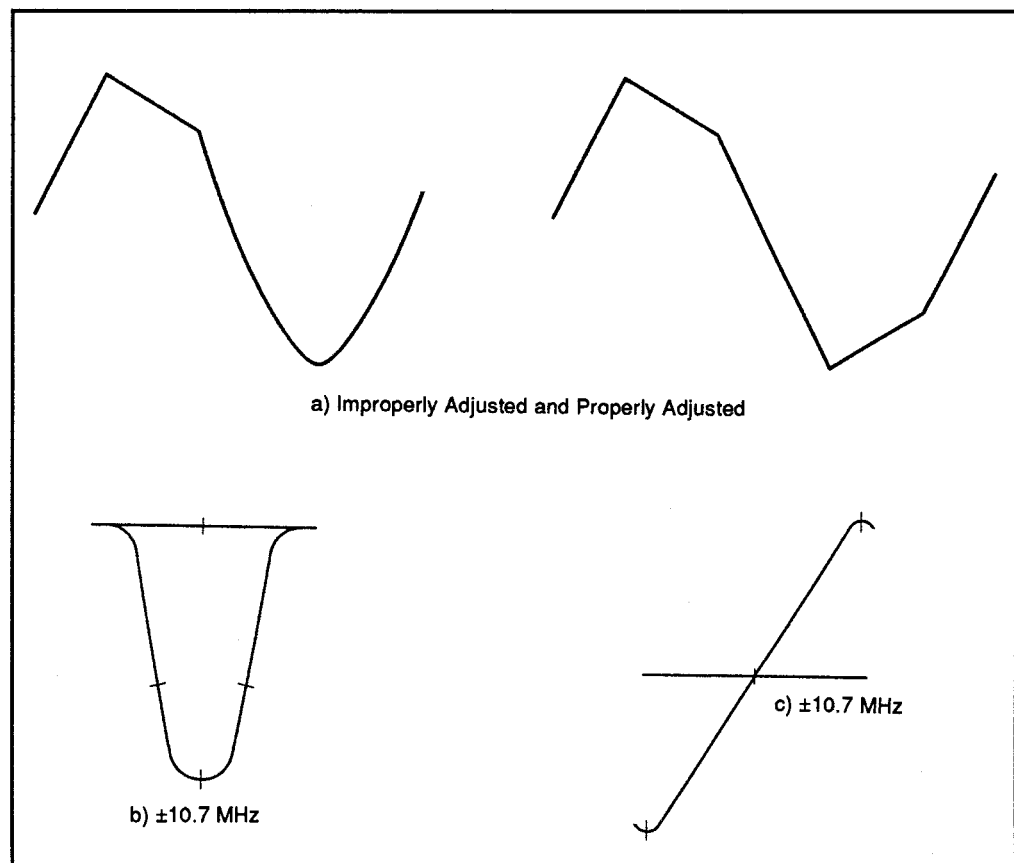
Watching the tape section gives you even more information. If it seems to be playing (i.e., the tape is moving), chances are good that the power supply is not the source of the problem.

### FM Multiplex

If there is a problem with the FM multiplex portion of the receiver, you must decide if the problem lies in the RF, IF or the detector portions of the receiver, or if the problem is indeed in the multiplex section at all. By using the composite output of the multiplex generator and injecting at the output of the detector, various problems can be found.

### Waveforms

Figure 1 shows the waveform patterns that should be found during testing. These waves can be found in many stages and used for troubleshooting. For example, if the waveform is missing at the third amplifier, but not after the second, check all the circuits between the second and third stages.



**Figure 1:** Waveform patterns for alignment, (a) improperly adjusted and properly adjusted; (b)  $\pm 10.7$  MHz markers in lower quadrants; (c)  $\pm 10.7$  MHz markers centered on cross-hair



**7/T**  
Tuner

7/T - VCS

7/T - VCS - ZXP

Various Case Studies

Zenith XP Tuner

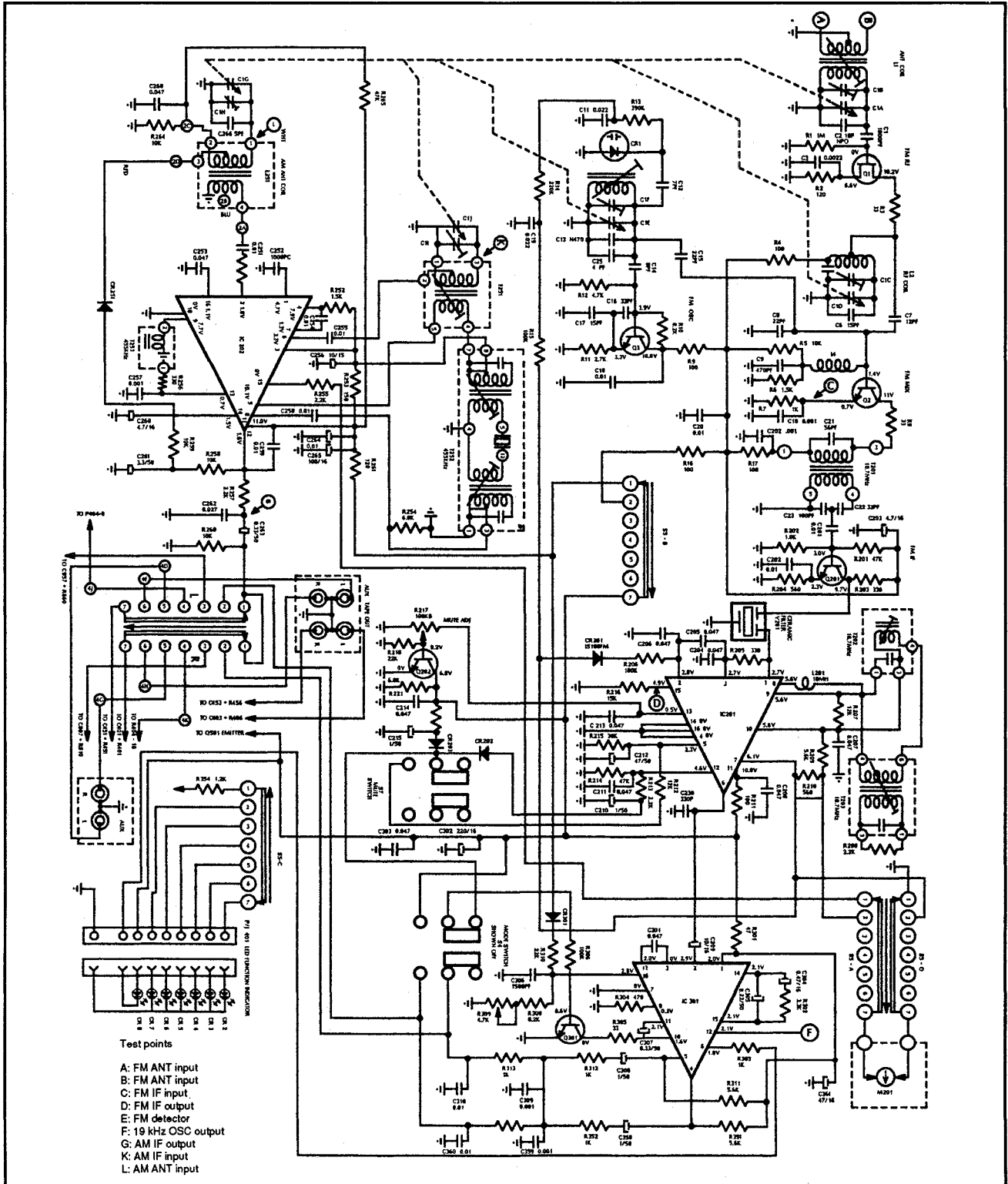


Figure 3: RF/IF/MPX schematic



The waveforms found should be similar in form and magnitude to those shown but may vary slightly from one unit to the next. Still, they are characteristic as to what will be seen in multiplex circuitry.

The various schematics that may be used for reference are shown in Figures 2 and 3. Figure 2 is the audio and power supply schematic. Figure 3 is the RF/IF/MPX schematic and is used when adjusting or repairing the AM and FM tuners.

### Schematics

These schematics are probably the best information possible for locating faulty components. Found at each transistor location is the correct voltage level that should be present when the unit is at rest (not passing a signal, but turned on). Simply checking these locations can help to isolate the problem. The ICs all have voltage level readings for all the pins. By using a DMM you can quickly ascertain whether a section is working properly or not, and, in most cases, discover the problem.

The test points are indicated through the text and on the schematic sheets fairly clearly. Locating them on the actual boards can sometimes be difficult, but, hopefully, the text will lead you to the correct location.

### AM Alignment

AM alignment should be done by the sweep method shown below. Aligning by alternate methods is not recommended, but may be necessary if your sweep generator does not have sweep capabilities for the AM IF.

### Test Equipment

For AM IF alignment you need an oscilloscope and an AM sweep signal generator or 10 kHz deviation and 60 Hz modulation for the full bandpass display. Make sure the unit is turned to the AM band and connect a modulation frequency to the horizontal input of the scope.

### Testing

Locate test point "L" (the AM antenna input). This is in the AM gang antenna section. Short this test point to chassis ground. Attach the generator output probe "A" as the dummy antenna.

The generator should be connected to test point "K", which is the AM IF input located at T251 pin 1. Connect the scope to the detector output, test point "G". Set the input frequency to  $\pm 455$  kHz and the dial so that the gang is closed. The generator should be set to the center frequency of the ceramic filter.

Next, tune the generator to the center of the total bandpass. The generator should not be changed for the rest of the AM IF alignment procedures.

7/T - VCS

Various Case Studies

7/T - VCS - ZXP

Zenith XP Tuner

With the gang closed, center the frequency of the ceramic filter in T252. This controls the amount of symmetry of the gain and should be adjusted for maximum gain and symmetry. Adjust T252 primary, T252 secondary and T253 for the alignment procedure. Adjust T253 to its maximum reading.

Next is the alignment of the oscillator to the dial scale. Begin by removing the short between test point "L" and the chassis ground. There should be no dummy antenna used for this alignment.

Connect the generator through one turn of wire loosely connected to the AM wave magnet antenna. Connect the oscilloscope to the detector output test point "G".

The input frequency for the first part should be set at 1600 kHz. Tune the dial to 1600 kHz as well and make adjustments at C1I until you detect the input signal of 1600 kHz when the dial is set at 1600 kHz.

Next tune the dial to 600 kHz and set the input signal frequency to 600 kHz. The scope should detect the signal of 600 kHz. If not, adjust T251 until this is so. Repeat these two adjustments until there is a minimum variance (maximum accuracy).

The next alignments are for the antenna stage. Set both the dial and the input frequency to 1400 kHz. Adjust C1H until the signals are matched.

Set the input frequency and the dial to 600 kHz. Adjust L251 if needed. Repeat the C1H and L251 steps until there is a minimum change. This concludes the AM alignment procedures.

### AM Alignment Without Sweep Generator

For a proper alignment without a sweep generator, use a signal with 400 Hz modulation. Set the receiver to the AM band. Begin as before by shorting the test point "L" (of the AM gang antenna section) to the chassis ground.

With the generator's probe A used as a dummy antenna, connect the generator to test point "K". Connect VTVM to the detector output test point "G". The input signal should be  $\pm 455$  kHz and the gang should be closed. The AM IF input is located at T251, pin 1.

Rock the generator while adjusting T252 primary for a maximum level. Next adjust T252 secondary for a maximum level. Continue adjusting the primary and secondary T252 until there is a maximum output and minimum change. Also, the output signals should be equal when the generator is detuned.

7/T - VCS

Various Case Studies

7/T - VCS - ZXP

Zenith XP

Next, send the input frequency to the ceramic filter in T252. Adjust T253 until there is a maximum signal.

Remove the short between the test point "L" and the chassis ground. (This disconnects the dummy antenna.) Connect the VTVM to the detector output test point "G". Loosely connect one turn of wire, with this coupled to the AM wave magnet antenna and thus to the receiver's generator.

Input a signal of 1600 kHz and tune the dial to 1600 kHz. Adjust C1I for the best signal. Input a signal of 600 kHz and set the dial to 600 kHz. Adjust T251 for the best signal. It's best to repeat these two adjustments at least twice for maximum signal and minimum change.

Change the dial setting to 1400 and input a signal of 1400 kHz. Adjust C1H for the best signal. Again tune the dial to 600 and input a signal of 600 kHz. Adjust L251 if needed. If an adjustment is needed, it is advisable to repeat each of these tests and adjustments.

## FM Alignment

### Multiplex

The FM signal circuitry is of a multiplex design. This means that the RF, IF and detector alignments must be set so that the unit works normally on monaural signals yet also decodes stereo signals.

The use of a multiplex generator is an excellent way of troubleshooting since there is the composite multiplex signal present along with the RF signal. This composite signal can be very useful for signal tracing the multiplex portion of the receiver.

The composite signal used for multiplex alignment must modulate the RF carrier. The input is to the FM antenna terminals. Alignment using this composite signal is then possible.

It should be noted that multiplex alignment cannot be made by using the composite signal injected at the output terminal of the detector. If the signal is injected at this point, there is always some phase shifting in the RF, IF or detector circuits. This can cause improper alignment.

The FM section uses a wide bandpass and requires the use of a signal generator that has frequency modulation of 50 Hz and a deviation of 250 kHz. You also need an oscilloscope to align the RF and FM sections of the receiver.

## IF Amplifier

The IF amplifier stages require a maximum amplitude and symmetry in order to achieve the best output signal. Use markers to obtain the IF curve symmetry. Put the receiver to the FM position. Set R217, R309 and T201 to the middle positions. Then connect the generator to the receiver, and connect the generator ground to the gang frame. The generator output probe "A" is connected as the dummy antenna.

Shunt C1E to ground with a .001 mF capacitor. Connect the generator to test point "C", which is the FM IF input found at emitter of Q2.

To align the IF transformer for maximum output and symmetry, and to achieve the scope pattern shown in Figure 1-b, connect the scope to test point "D" (found at IC201, pin 15). The input signal should be set to 10.7 MHz and the gang closed. Tune the generator to center the total bandpass waveform.

Do not change the generator frequency for the rest of the tests. The input frequency should be the center frequency of the ceramic filter, Y201. Refer to the following table for the ceramic filter types and their frequencies.

Ceramic Filters		
Color Code	Nominal Center Frequency	Frequency Range
Black	10.64 MHz	10.61 to 10.67 MHz
Blue	10.67 MHz	10.64 to 10.70 MHz
Red	10.70 MHz	10.67 to 10.73 MHz
Orange	10.73 MHz	10.70 to 10.76 MHz
White	10.76 MHz	10.73 to 10.79 MHz

Adjust T201, top and bottom, until the scope pattern is the same as Figure 1-b. This concludes the IF transformer alignment.

The FM detector alignment uses a signal of 75 kHz deviation with a 1 kHz modulation. (If the generator being used does not have the ability to provide output for audio modulation, use the horizontal output from the generator, or the oscilloscope's horizontal sweep.) Connect the generator modulation frequency to the oscilloscope's horizontal input. Adjust the generator IF frequency to be at the center of the bandpass waveform.

Connect the generator to test point "C" (the FM IF input at the emitter of Q2). The generator output probe "A" is again connected as the dummy antenna.

Using a distortion analyzer connected through A100, check the center frequency of the ceramic filter Y201. (Refer to Table 1 for the correct frequency reading.) Adjust T203 to read the minimum distortion level.

If a distortion analyzer is not available, connect the oscilloscope to test point "E" (the FM detector output, pin 6 of IC201). Make sure the gang is closed. Adjust T203 to read a linear scope trace with no curve at the ends of the trace.

Next, with the oscilloscope connected to test point "E" (pin 6 of IC201), adjust T202 to achieve a center reading on the tuning meter.

### Mute Adjustment

Remove the shunt across C1E. Disconnect the FM antenna, then connect the generator between test points "A" and "B", the FM antenna inputs. A 300 $\Omega$  balanced load serves as the dummy antenna to the receiver. Feed a 98 MHz signal to the unit with the dial set to 98 MHz. Adjust R217 (mute) so there is no sound output when the input is below 1.7 V with the mute switch on.

Set the input signal to 106 MHz and the dial to 106 MHz. Adjust C1F so the oscillator is the same as the dial scale.

Set the input signal to 90 MHz and the dial to 90 MHz. Adjust L3 to assure that the oscillator output is the same as the dial scale.

Set the input signal to 106 MHz and the dial to 106 MHz. Adjust C1C so that the FM detector stage is maximized.

Set the input signal to 90 MHz and the dial to 90 MHz. Adjust L2 (if necessary) to assure the detector stage is maximized.

Repeat each of the last four steps until the FM antenna stage is maximized. This concludes the mute adjustments.

### Left/Right Alignment

Connect a frequency counter or oscilloscope to test point "F". This is the 19 kHz oscillator output found at pin 12 of IC301. Input an unmodulated RF carrier signal to the unit. The signal should be about 100 V which will obtain a full-limiting effect at the point near 98 MHz. Adjust R309 until the frequency counter reads about 19 kHz  $\pm$ 100 Hz.

An alternate method would be to connect test point "F" to the oscilloscope's vertical input and an accurate 19 kHz signal to the oscilloscope's horizontal input. Adjust for a square synchronized waveform.

Connect the scope and/or a DMM to the left tape output. Feed a 98 MHz signal to the unit. Try each of the settings, L+R, L-R and L only. Check for separation and a maximum left output. Connect the oscilloscope and/or DMM to the right output and repeat the process.

This concludes the FM alignment and testing.

### RF Injection

RF signals should be injected at a point in the FM band where there is no other signal present (to avoid interference and/or false readings). When possible, the center of the band is preferred.

### Audio Alignment

Adjust the generator's RF input frequency to the same point. The AGC signal should be maximized. This determines whether the unit is on the correct signal and not an image.

Audio alignment assures that the audio output for the left and right channels are at the proper levels. To begin the adjustment, set the bass, treble and balance controls to their middle positions. The volume should be turned down. Adjust the output stages for proper idle current with no signal input before performing the adjustments.

With no input signal, connect the DMM across R446. Adjust R441 for a 10 mV (20 mA) reading across this resistor. Repeat the procedure with the meter across R496. This is the best method for making the audio output idle current adjustments.

An alternate method is also available. Again, set the the bass, treble and balance controls to their center positions. Set the idle current controls R441 and R491 to their minimum positions. Connect the generator to the right auxiliary input with an input signal of 20 kHz at 150 mV. Connect the oscilloscope to the right speaker output. Adjust R441 until the crossover distortion just disappears.

Move the generator to the left auxiliary input with the same input of 20 kHz at 150 mV. Move the scope to the left speaker output. Adjust R491 until the crossover distortion disappears.

To adjust the audio output driver bias, set the controls as before (bass, treble and balance controls to the middle position and the volume all the way down). Connect the generator to the right auxiliary input and the oscilloscope to the right speaker output. The input signal should be set to 60 Hz at 180 mV. Adjust R433 to obtain an equal clipping on both peaks of the waveform. If needed, increase

---

7/T - VCS

Various Case Studies

---

7/T - VCS - ZXPZenith XP Tuner

---

the generator level slightly to achieve a clipping effect. The scope pattern should look like that shown in Figure 1 (a) (see page 2).

Move the generator connection to the left auxiliary input and the scope to the left speaker output. The generator should be the same as before. Adjust R483 and obtain the waveform like that of Figure 1 (a). This concludes the audio output driver bias adjustments.

**7/T**  
Tuner

---

7/T - VCS

Various Case Studies

---

7/T - VCS - ZXP

Zenith XP Tuner

---



# Section 8

# Automobile Electronics

---

## Table of Contents

<b>8/TE</b>	<i>Test Equipment</i>
<b>8/TR</b>	<i>Troubleshooting and Repair</i>
<b>8/TR - ECM</b>	<i>Electronic Control Module</i>
<b>8/TR - ECM - CC</b>	<i>Cruise Control</i>
<b>8/TR - ECM - CL</b>	<i>Code Listings</i>
<b>8/TR - PS</b>	<i>Power Systems</i>
<b>8/TR - PS - BS</b>	<i>Battery Systems</i>
<b>8/TR - PS - CS</b>	<i>Charging Systems</i>
<b>8/TR - R</b>	<i>Radios in Automobiles</i>
<b>8/VCS</b>	<i>Various Case Studies</i>
<b>8/VCS - GM</b>	<i>General Motors</i>
<b>8/VCS - GM - CKPT</b>	<i>CK Pickup Truck</i>

Table of  
Contents

---

---

---

---

**8/TE**  
Test Equipment

---

8/TE

---

Test Equipment

---

---

**8/TE**  
**Test Equipment**

---

There are a variety of electronic test items that can be used with automobiles. Short of having an automobile electronic testing and scope unit, your most important piece of test equipment will be the DMM.

**DMM**

The DMM must be able to measure high impedance. A DMM with a 10 M $\Omega$  input impedance should be used because this type of meter will not load down the circuit and create a faulty readings. Some circuits in the Electronic Control Module (ECM) have a very high resistance.

**Test Light**

An unpowered test light can be very handy in locating shorts to ground or voltage. This test light can also be used to check wiring for complete circuits (e.g., continuity).

**Circuit Tester**

A circuit tester is needed to check all relays and solenoids before connecting a new Electronic Control Module. The circuit tester will indicate a pass or fail response (via a red or green LED) and usually the polarity of the circuit being tested. (A DMM could probably be used for most of these tests.)

**Miscellaneous**

Various other test items may, or may not be required. Refer to the automobile-specific manuals to determine needed equipment.

**8/TE**  
Test Equipment

8/TE

Test Equipment

**8/TR**

Troubleshooting

8/TR - EC

Electronic Controls

8/TR - EC - CC

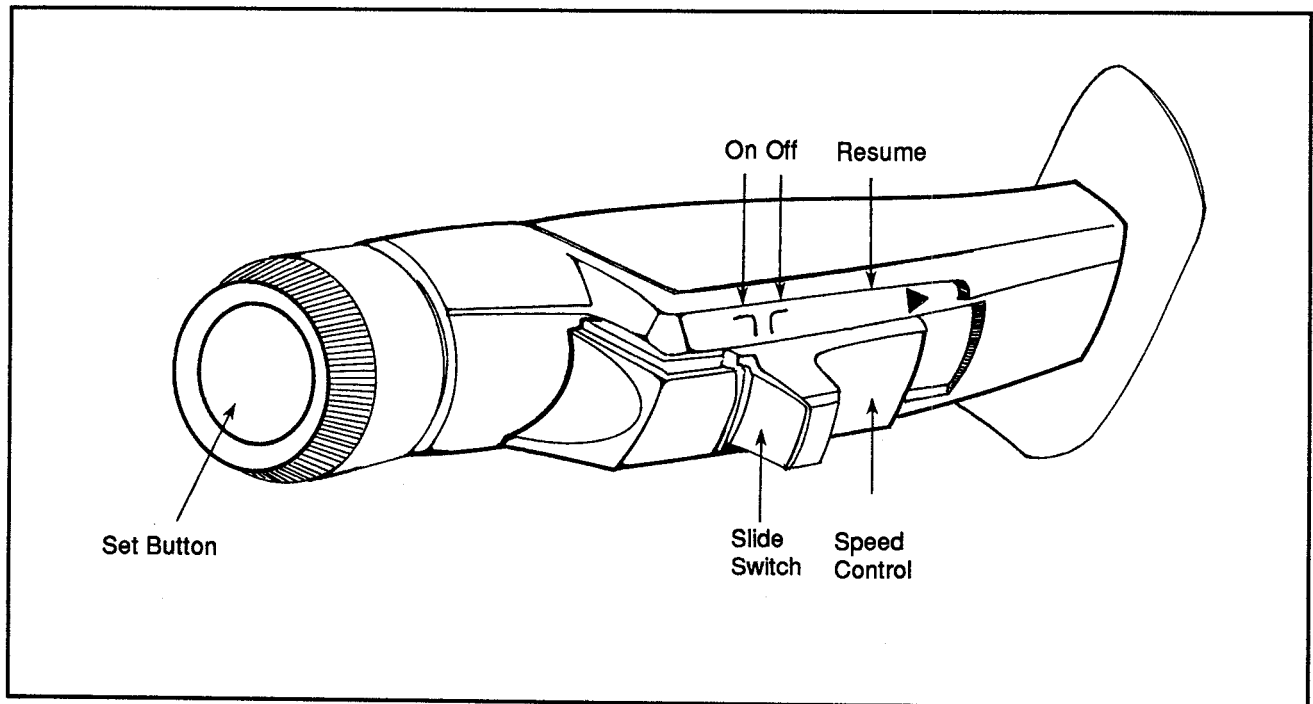
Cruise Control

**8/TR - EC**  
**Electronic Controls****8/TR - EC - CC**  
**Cruise Control**

The electronic cruise-control system can be either a vacuum link system or an electro-motor cruise (or may be available in some other configuration). Figure 1 shows a typical cruise-control switch. This will often be mounted as part of the turn signal lever.

**Vacuum Cruise Control**

The vacuum cruise-control system is electrically actuated and vacuum operated. The multifunction control switch is located on the left side of the steering column and has a slide switch which has three positions, ON, OFF, and Resume with a Set button located at the end of the stick. This type of system is designed to operate at speeds above 30 MPH.



**Figure 1:** Cruise control switch

# 8/TR

Troubleshooting

8/TR - EC	Electronic Controls
8/TR - EC - CC	Cruise Control

When the Set button is pressed, it will engage the system, setting the speed to remain at the current speed. A normal braking action, or even a slight tap on the brake, will cause the cruise control to disengage. It can be reset by pressing the Resume button.

By switching the ON/OFF switch to the OFF position, it will cancel the current cruise control, and clear any preset cruise value.

If the accelerator is depressed further than the current cruise speed, the vehicle will increase in speed. After releasing the accelerator pedal, the cruise control will resume the set speed.

To test the cruise control the vehicle will need to be road tested (driven and tried). A broken speedometer cable from the transmission to the speed control servo will disable both the speed control system and the speedometer. Flutter in the speedometer can cause surging in the speed control system. Any problems with the speedometer must be corrected before proper testing of the cruise controller is possible.

Electrical tests at the servo are done with a 12 V test lamp, using a test clip at one end and a straight probe at the other. A good servo ground is necessary before proceeding to other electrical tests.

The test clip is connected to the positive battery terminal. The test probe is touched to the metal cover of the servo (refer to the service manual for the location of the servo). The lamp should light. In the lamp fails, there is a poor ground. Repair the ground connection.

Connect the test lamp between ground and the brown wire with the red tracer. The ignition switch is then turned on and the cruise control set to the ON position. The test lamp should come on. Push the Set button and see if the lamp goes out. Listen for a click at the servo. If the test lamp does not respond correctly, there is a blown fuse, a defective control switch, or faulty wiring. If the click is not heard at the servo, the servo is defective. Replace the bad item or fix the wiring.

Next, connect the test lamp from ground to the white wire with the red tracer. Turn the ignition and cruise switch to the ON position. Push the Set button. The test lamp should come on when the Set button is depressed. If the lamp does not respond correctly, there may be a defective switch or bad wiring.

The next step is to connect the test lamp between ground and the blue wire with the red tracer. Again, turn the ignition and cruise-control switch ON. The test

# 8/TR

Troubleshooting

8/TR - EC

Electronic Controls

8/TR - EC - CC

Cruise Control

lamp should be lit. If not, there may be a bad brake switch, clutch switch, cruise control switch, or bad wiring.

To check the parts of the cruise control switch, disconnect the wiring harness leading up the steering column. Connect a 12 V positive source to the yellow wire terminal in the cruise-control harness connector (male). Attach one lead of the test lamp to ground and the other to the brown wire with the red tracer terminal. The test lamp should be on when the cruise-control switch is in the ON position. The test light should be off when the Set button is pushed or when the cruise switch is off.

Move the test lamp lead to the dark blue wire with the white tracer. The test light should be on when the slide switch is in the ON position. It will be off when the switch is in the OFF position.

Next, move the test lamp lead to the white wire with the red tracer. The test lamp will be off when the slide switch is in the ON position. The test light should go on when the Set button is depressed and off when the button is released. The lamp will go on when the slide switch is moved to the Resume position and off when released.

If any of the above are not working correctly, the switch is most likely bad and should be replaced. It may be possible that the wire connections are bad or broken and could be in need of repair.

## Vacuum Supply Test

This is more of a mechanical repair than an electronic one, but the vacuum can cause the servo to appear as it is failing.

Disconnect the vacuum hose at the servo and install a vacuum gauge in the hose. Start the engine and note the gauge at idle. The vacuum gauge should be reading about ten inches of mercury. If not, check for vacuum leaks (as specified in the service repair manual) and/or replace the vacuum hose.

## Adjustments to the Cruise Control

The clevis of the cruise-control cable is retained on the stud of the lost motion line by a spring clip. This is shown in Figure 2. A visual inspection will verify if this connector is working properly or not.

The cruise control cable is connected to the servo by means of a wire clip as shown in Figure 3. If the clip is missing, the cruise control will not work. The cable is connected to a cable support bracket by a clip located about seven inches from the stud on the lost motion link. The engine will need to be started and run until it is at operating temperature.

**8/TR****Troubleshooting**

8/TR - EC

Electronic Controls

8/TR - EC - CC

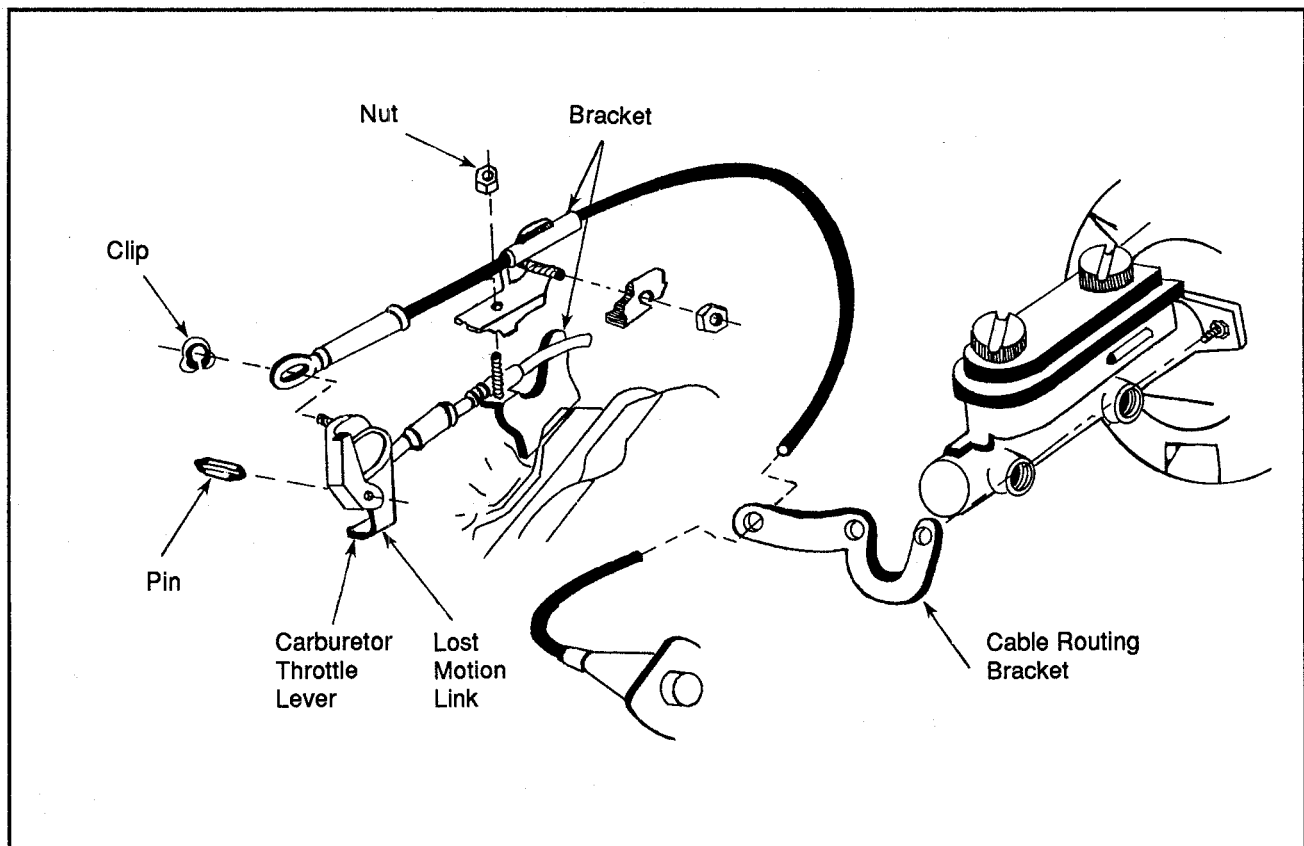
Cruise Control

The spring clip from the lost motion link stud should be removed. The clearance between the stud and the cable clevis is about 1/16 of an inch (1.66 mm). A gauge pin should be inserted between the cable clevis and the stud.

Loosen the clip at the cable support bracket and remove any slack from the cable. Tighten the clip at the cable support bracket to the specified setting (e.g., 45 in./lb.)

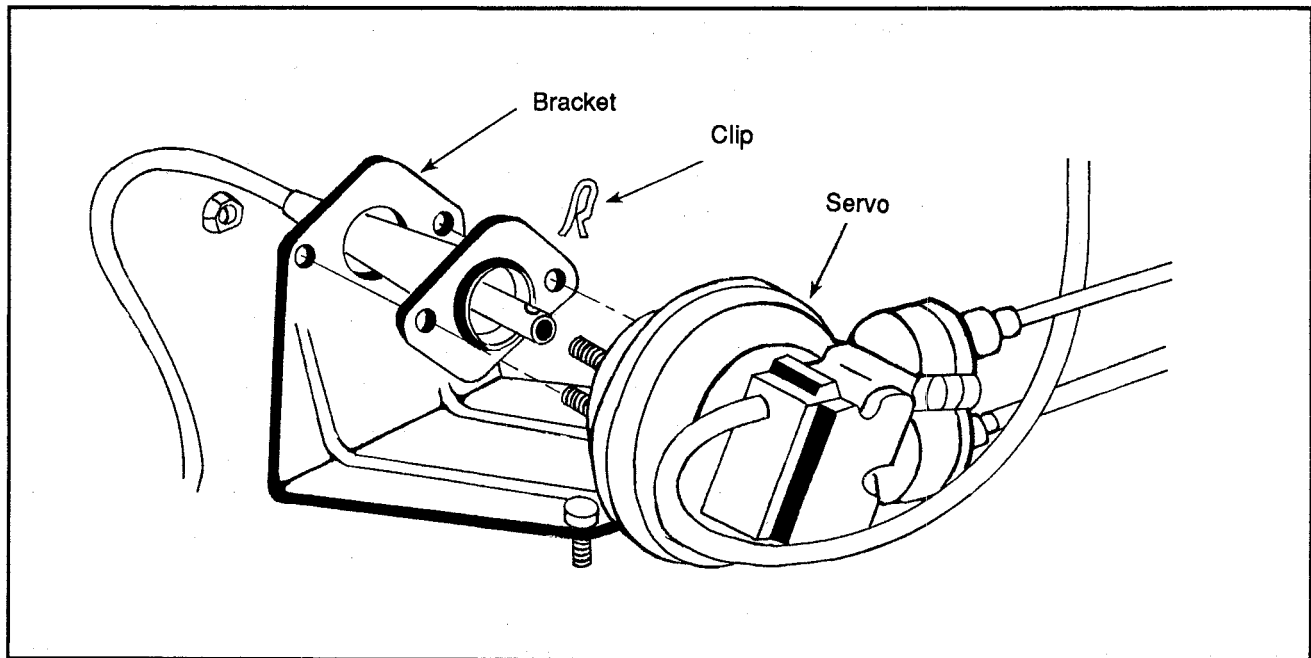
The lock screw adjustment controls the lock-in occurrence of the cruise control unit. When the Set button is pushed and released at speeds greater than 30 MPH, the speed control system is activated and the system locks in and holds the vehicle at virtually the same speed at which it is moving.

If the engine is poorly tuned, the vehicle is overloaded, or there is slack in the throttle control cable, the lock-in screw will be affected. The screw can only be



**Figure 2:** Cruise control throttle cable





**Figure 3:** Cruise control cable as connected to the servo

accurately adjusted after proper diagnosis of the cruise-control system operation. The screw should never be turned more than 2 turns in either direction or damage to the unit may occur.

### Electro-Motor Cruise Control

The electro-motor cruise control is a speed control system which maintains a desired vehicle speed under normal driving conditions. It has the ability to cruise, coast, resume speed, accelerate, or have the speed increased/decreased in increments. This system operates more smoothly than does the vacuum control system.

The cruise control system uses a control module to obtain the desired vehicle cruise operation. In the module can be found an electronic controller and an electric motor. The controller monitors vehicle speed and controls the motor.

The motor moves a connecting strap and throttle linkage in response to the controller to maintain a constant desired speed. The controller has a built in limit that will not allow it to operate at speeds below 25 MPH.

The cruise system is controlled from the turn signal mounted cruise controller as shown before in Figure 1. There are two to three electrical release switches to disengage the cruise system. Two are located on the brake pedal and the other

**8/TR**  
Troubleshooting

---

8/TR - EC

Electronic Controls

---

8/TR - EC - CCCruise Control

---

can be found on the clutch pedal bracket (for those vehicles with manual transmission).

The brake pedal uses two switches to stop cruise control on a vehicle with cruise. The combined stop control switch and a plunger type release switch are used. When the brake pedal is pushed, each switch stops the cruise control system. The cruise system will remain disengaged after the release of the brake pedal.

The cruise control module will be found in the engine compartment. Consult the service manual for the specific vehicle for the location. If the unit becomes faulty, it cannot be repaired but must be replaced. With virtually no exceptions, the only source of replacement will be a factory authorized dealer.

Testing the unit is pretty much limited to checking cable connections, cruise switch operation and fuse checks. These were explained in the vacuum section and will apply here as well.

---

## 8/TR

### Troubleshooting and Repair

---

## 8/TR - ECM

### Electronic Control Module

---

#### Introduction

The Electronic Control Module (ECM) has a computer to control fuel delivery, air management, some emission control systems and ignition timing. It may also control the transmission converter clutch, the downshift controls and the manual shift light. The one described in this section should work with most GM automobiles built after 1981.

#### Operating Procedure

It's not uncommon for the ECM to be damaged even by things seemingly unrelated. For example, ECMs have been ruined when a car has been in for repainting. The operating temperature of a typical ECM must be under 185° F. When an automobile is put into a baking oven, temperatures will often exceed this level. The ECM may need to be replaced afterwards, or be insulated against these temperatures.

#### Scan Tool

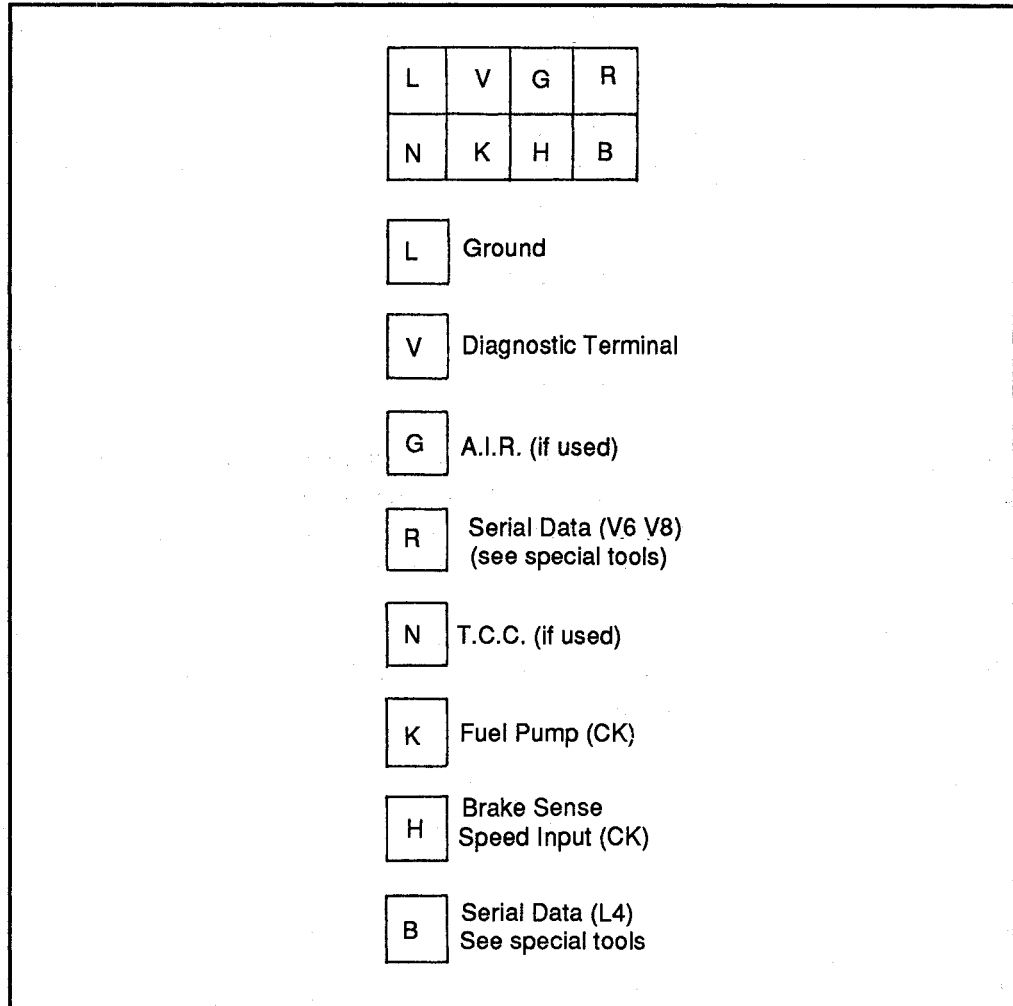
Normally, the ECM is diagnosed with a scan tool which is interfaced to the computer command control system. The system can, however, be checked using an ordinary DMM.

The scan tool is designed to interface with the ECM, supplying a visual reading of most inputs to the ECM and some outputs. To understand the use of the scan tool, review the instructions supplied with it. The scan tool stores and displays codes reported by the ECM. These codes lead you to the area with the fault. These codes are most likely automobile specific, (GM codes are GM codes, etc.) and are not reproduced here.

#### Block Connector

Figure 1 shows a typical block connector which is connected to the ECM. This connector is usually found under the dash on the driver's side nearest the door and is called the Assembly Line Diagnostic Link (ALDL). There may be an access panel that has to be removed to get to the ECM connector. The various pins used are discussed as follows:

- Pin A is used as a ground for the other pins.

**8/TR****Troubleshooting**

**Figure 1:** Terminal block for GM electronic control modules

- Pin B is the “diagnostic terminal”. If this pin is grounded (connected to Pin A, the “Service Engine Soon” (SES) light will flash codes entering the Diagnostic Mode. This is done with the key turned on and the engine not running. If the engine is running, the light will flash Field Service information to determine if the system is in a “Closed Loop” or “Open Loop” operation mode.
- Pin C is used to diagnose some air management systems and is wired to the ground side of the electric air control valve.
- Pin E is the serial data line on many different types of vehicles and is used by the “Scan” tool to read various system data information.

- Pin F is used to diagnose the transmission converter clutch (TCC) system and is wired to the ground side of the TCC solenoid.
- Pin G is used to diagnose the fuel pump circuitry on many different vehicles. If not tested here, the test points will be in the engine compartment near the fuel pump relay.
- Pin H is used to check the braking system of many vehicles.
- Pin M is a serial data line used by the “Scan” tool to read various system data information.

**Diagnostic System**

The Electronic Control Module system has a diagnostic system built into it. If any problem in the engine has been detected while the engine is running, the “Service Engine Soon” light on the instrument panel will be lit. This light will also be used for a bulb and system check.

**Alternate Testing Tools**

Without the use of the “Scan” tool, these tests can be done with the use of a tachometer, test light, DMM with 10 M $\Omega$  impedance, a vacuum gauge and various jumper wires.

**Codes**

The various codes that may be reported (either by using the “Scan” tool, or the “Service Engine Soon” light) are listed below. Note that these codes do not apply to all vehicles.

CODE	CIRCUIT	CAUSED BY
12	ECM	Diagnostic mode.
13	O <sub>2</sub> Sensor	The oxygen sensor circuit or sensor was open for one minute when off idle. Could be an open oxygen sensor circuit.
14	Coolant Sensor	High temperature indication. The sensor or signal line becomes grounded for 3 seconds.
15	Coolant Sensor	Low temperature indication. The sensor, connections, or wires open for 3 seconds.
21	Throttle Position Sensor (TPS)	Signal voltage high. TPS voltage greater than 2.5 V for 3 seconds with less than 1200 rpm.
22	TPS	Signal voltage is low. A shorted (to ground) or open signal circuit will produce code in 3 seconds.
23	Manifold Air Temperature Sensor (MAT)	Low temperature indication. Occurs when connections or wires are open for 3 seconds.

CODE	CIRCUIT	CAUSED BY
24	VSS	No vehicle speed present during a road load deceleration.
25	MAT	High temperature indication. Signal line becomes grounded for 3 seconds.
32	Exhaust Gas Recirculation (EGR)	Vacuum switch shorted to ground on start-up. Switch not closed after the ECM has commanded EGR for a designated period of time. EGR solenoid circuit open for a designated period of time.
33	Manifold Absolute Pressure Sensor(MAP)	Low Vacuum. MAP sensor output to high for 5 seconds or an open signal circuit.
34	MAP	High Vacuum. Low or no output from sensor with engine running.
35	Idle Air Control (IAC)	IAC error.
42	Electronic Spark Timing (EST)	ECM has detected an open or grounded EST or Bypass circuit.
43	Electronic Spark Control (ESC)	Signal to the ECM has remained low for too long or the system has failed a functional check.
44	Lean Exhaust Indicator	Oxygen sensor voltage remains below 0.2 V for about 20 seconds.
45	Rich Exhaust Indicator	Oxygen sensor voltage remains above 0.7 V for about 1 minute.
51		Faulty MEM-CAL, PROM, or ECM.
52		Fuel CALPAK missing or faulty.
53		System over voltage. Indicates a basic generator problem.
54	Fuel Pump	Low voltage. Fuel pump voltage is less than 2 V when reference pulses are being received.
55	Computer Control Module	Faulty ECM.

**Bulb Check**

With the ignition switch turned on, and the engine not running, the "Service Engine Soon" light should be on. This indicates that the ECM has made a complete circuit to turn the lamp on. If the lamp does not come on, the bulb will need to be replaced. Refer to the service manual for proper removal and replacement of the bulb.

**System Check**

The system check will be done by using the ALDL connector found under the instrument panel. Terminal B (diagnostic terminal) should be jumpered to

terminal 1 (ground). The ECM will enter either the diagnostic mode or the field service mode.

**Clearing Codes**

When the ECM stores a code, the “Service Engine Soon” light will come on and a code is stored in memory. If the problem is intermittent, the light will go out after 10 seconds as the fault disappears. The code will be stored in memory for 50 engine starts, or until the battery voltage has been removed for at least 30 seconds. Codes will need to be cleared after any repairs have been made. Some diagnostic charts will tell you to clear the codes prior to using the chart. This allows for locating errors faster.

The ECM can be easily damaged when connecting/disconnecting power. The key switch should be off when removing power (either by the battery cable, ECM pigtail, ECM fuse, etc.).

**Diagnostic Mode**

The diagnostic mode has been entered when the ignition is on and the engine is stopped. Terminal A and B are jumpered together. The “Service Engine Soon” light will flash a code 12 to indicate that the diagnostic system is working. This coding is done in a sort of Morse code fashion. The light will blink once for the tens column, pause, then blink twice for the ones column. This code will be repeated three times and will continue to repeat if no other codes have been stored in the ECM.

Any other stored codes will then be flashed. An example of this would be code 54. This would indicate a problem with the fuel pump. The light would flash five times, then a short pause and flash four times. Each code will flash three times, and then return to the code 12 and start the cycle over again. Refer to the code chart listed above for meanings of various codes.

Codes can be obtained only when the engine is not running and the ignition is on. All computer-controlled relays and solenoids are energized in the Diagnostic Mode with the exception of the fuel pump relay.

**Field Service Mode**

If terminal B is grounded to terminal A when the engine is running, the system will enter the Field Service mode. The “Service Engine Soon” light will show whether the system is in the “Closed Loop” or “Open Loop” mode, and if the fuel system is operating normally.

With the terminals grounded, the engine at normal operating temperature, and running at 1400 to 1600 rpm for at least two minutes, the light can be checked.

When the fuel system is operating normally and the system is in a “Closed Loop” mode, the light will be flashing at a rate of once per second. If the light is flashing at 2.5 times per second, the fuel system is in an “Open Loop” condition. This indicates that the oxygen sensor voltage signal is not being properly sent to the ECM.

The system will flash “Open Loop” after the engine starts for 30 seconds to 2 minutes or until the sensor reaches normal operating temperature. If the system fails to go to a “Closed Loop”, the fuel pump may need repair work, or sensor replacement.

If the light remains on most of the time, it indicates that the exhaust is rich. The oxygen sensor signal voltage will be above 0.55 V and steady. This will be indicated by a code 45.

If the light remains off most of the time, it indicates that the exhaust is lean. The oxygen sensor signal voltage will be less than 0.35 V and steady. This will indicate a code 44.

**ECM Replacement** When the automobile key switch is turned on, the ECM begins a diagnosis of all items within its control, including itself. The code system will indicate a failure of a specific circuit, or the ECM. If the ECM fails and needs replacing, it will give a code 55.

If the ECM was replaced and the error was not corrected, the following information may be the cause:

- A shorted solenoid, relay coil or harness may cause a ECM fail. A short test should be used to test the connection harness.
- The PROM/MEM-CAL could have possibly failed. It operates as part of the ECM and may need to be replaced. A bad PROM or MEM-CAL installation error will usually return a code 51.
- An incorrect PROM/MEM-CAL application can cause malfunctions and may or may not send a code.
- The connector at the ECM may be the problem and need to be removed and checked.
- The new ECM may be faulty.



**ECM Intermittent Codes**

An intermittent code means that a code is stored in the memory, but the circuit is OK. Most intermittent problems are caused by faulty electrical connections or wiring. Careful checking of the wiring associated with the problem area will need to be done. Check the wiring diagrams in the service manual for the specific vehicle.

There could be a poor mating of the connector halves, or the terminals are not fully seated in the connector body. Ensure that the connectors are making good contacts and are not being inhibited by some foreign object or have other gapping problems.

If the problem cannot be located, connect a DMM to the suspected circuit and measure the voltage while operating the vehicle.

If there is a loss of a code in memory, you will need to disconnect the TPS and idle the engine until the "Service Engine Soon" light comes on. Code 22 should be stored and kept in memory after the ignition is turned off for at least 10 seconds. If this doesn't happen, the ECM is at fault.

A defective relay, solenoid, or switch may cause electrical system interference to occur. There will usually be a sharp electrical surge present. The problem will most often be found when the faulty component is operating. Improperly installed electrical components (lights, radios, CD-players, etc.) could be the cause of the problem.

**8/TR**  
Troubleshooting

---

8/TR - ECM

---

Electronic Control Module

---

---

8/TR - ECM	Electronic Control Module
8/TR - ECM - CL	Code Listings

## 8/TR - ECM

### Electronic Control Module

## 8/TR - ECM - CL

### Code Listings

#### Step-By-Step Instructions For Code Listings

Many of the various Electronic Control Module (ECM) codes are listed below and with step-by-step instructions to locate the problem. The codes chosen will work for a variety of makes and models of GM vehicles. They may or may not work for all models. These are example steps to help in troubleshooting various electronically controlled devices and sensors to be found in a vehicle.

#### Oxygen Sensor Circuit Code 13

Code 13 is sent for errors in the oxygen sensor circuit for all GM engines. This will occur with the engine at normal operating temperature. The terminals A and B are shorted and the engine is in the Field Service Mode. The engine should be run at 1200 rpm for one minute. View the “Service Engine Soon” light.

If there is a flashing “Open Loop” condition (flashes at a rate of 2 times per second), the ignition should be turned off. The oxygen sensor should be disconnected, and connector circuit 412 should be jumper harnessed to ground. Start the engine and observe the SES light. If it flashes “Open Loop” for about 1 to 4 seconds, then goes OFF for at least 30 seconds, the oxygen sensor or connector is bad and should be replaced.

If the “Open Loop” test doesn’t happen, turn the engine off but leave the ignition switch on. Check the voltage of circuit 412 (refer to the service manual for the location of this) at the O<sub>2</sub> sensor harness connector using a DMM. The reading should be 0.3- 0.6 V (300-600 mV). If the voltages check out, the fault could be the ECM and not the oxygen sensor, an open circuit 413, or open circuit 412.

When the flashing code indicates a “Closed Loop” (flashes at 1 time per second), refer to the intermittent codes section discussed above. Intermittent responses are discussed for some of the codes listed, but not for all. The intermittent problem can occur for any of the codes that can be reported.

**8/TR****Troubleshooting**

8/TR - ECM

Electronic Control Module

8/TR - ECM - CL

Code Listings

**Coolant  
Temperature  
Sensor Circuit -  
Code 14**

Run the engine for at least one minute, or until the SES light comes on. Turn the ignition switch off from the Run position so the engine stops. Do not turn the key all of the way off, as this will clear the code. Ground terminals A and B on the ALDL and note the code.

If the code is 14, turn the ignition off to clear the code. Disconnect the coolant sensor. Start the engine and run for 1 minute or until the SES light comes on. Turn the ignition switch to the ignition on and engine stop mode. Connect the ALDL terminals A and B. If there is still a code 14, check to see if circuit 410 is shorted to ground, or circuit 410 is shorted to a sensor ground circuit or a faulty ECM. If the code is code 15, replace the faulty coolant sensor.

**Coolant  
Temperature  
Sensor Circuit -  
Code 15**

Begin with the engine off (to clear codes 14 and 15) and the ALDL terminals A and B not shorted. Start the engine and run for 1 minute or until the SES light comes on. Turn the ignition to the on mode with the engine stopped. Connect terminal A and B of the ALDL. Note the code from the SES.

If the code is 15, turn the ignition off to clear the codes. Disconnect the coolant sensor connector. Jumper the harness terminals together. Start the engine and run for 1 minute, or until the SES light comes on. Turn the ignition key to the ignition on and engine stopped position. Connect terminal A and B of the ALDL and note the code on the SES.

If the code is 15, leave the ignition on, and the engine stopped. View the coolant sensor harness circuit 410 with a DMM and check for voltages between 4 and 6 V. If found, the sensor ground circuit is open or the ECM connection is faulty or the ECM is bad. If the voltage is not found, circuit 410 is open or faulty or the ECM connector or ECM is bad.

If the code is 14, the coolant sensor connection, or coolant sensor is bad. Replace the sensor and/or check the connection.

**Throttle Position  
Sensor Circuit -  
Code 21**

For this test, the engine should be at normal operating temperature. The ALDL terminals A and B should not be connected. Turn the engine off to clear codes. Start the engine and idle in the neutral position with the AC off. Do this for 1 minute, or until the SES light comes on. Turn the key to ignition on, and the engine stopped. Connect terminals A and B of the ALDL and note the code.

If the code is 22, check the TPS sensor ground harness connector with a test light hooked to 12 V. If the light is on, the TPS connector or sensor is bad. If the light is off, there is an open sensor ground, bad connection or bad ECM.

**Throttle Position  
 Sensor Circuit -  
 Code 22**

If the code is 21, check to see if circuit 417 is connected to a voltage source or if the ECM is faulty. If there is no code 21 or the problem is intermittent, or if no other code is stored, refer to Section "8/TR-ECM" Page 7.

For this test, the engine should be at normal operating temperature. The ALDL terminals A and B should not be connected. Turn the engine off to clear codes. Start the engine and idle in the neutral position with the AC off. Do this for 1 minute, or until the SES light comes on. Turn the key to the ignition on, and with the engine stopped. Connect terminals A and B of the ALDL and note the code.

If the code is not 22, or the problem is intermittent, or if no other code is stored, refer to Section "8/TR-ECM" Page 7.

If the code is 22, disconnect terminals A and B. Turn the ignition off to clear the codes. Disconnect the TPS and jumper a 5 V reference circuit to the TPS signal circuit at the harness connector. Start the engine and idle as before. After the SES light has lit, shut off the engine and turn the ignition switch to on. Note the code.

If the code is 21, adjust the TPS (if adjustable) to manufacturer specifications. If no adjustment is possible, replace the TPS.

If the code is 22, remove the jumper and check for a 5 V reference signal from the ECM at the TPS harness connector F. If the voltage is 4 to 6 V, there is an open or short to ground in the signal circuit or a faulty connector or ECM. If the voltage is below 4 V, there is an open or short to ground in the 5 V reference circuit, a faulty connection, or bad ECM.

**Vehicle Speed  
 Sensor Circuit -  
 Code 24**

The type of vehicle speed sensor must be determined before continuing, otherwise a misdiagnosis might occur. This code can be disregarded if it occurs when the drive wheels are not turning.

To check the speed sensor, the speedometer should be functional, as should the cruise control. If either of these items is experiencing problems, they should be corrected first. Shut off the cruise control. Since the drive wheels must be turning, they will have to be lifted. If this is not possible, the test will have to be conducted while driving the vehicle.

You will be probing the ECM connector with a DMM, checking for a voltage on circuit 437. Start and idle the engine in the "Drive" mode. The voltage reading should be a varying voltage between 1 and 6 V.

If the voltage is less than 1 V, check circuit 437 for a short to ground. Check the ECM for a poor connection.

**8/TR****Troubleshooting**

8/TR - ECM

Electronic Control Module

8/TR - ECM - CL

Code Listings

If the voltage is 5 to 12 V and steady, check circuit 437 for an open. If circuit 437 and the ECM connections check out OK, check for a bad vehicle speed sensor or buffer assembly. Refer to the electrical section of the chassis service manual for the vehicle under test.

**Map Sensor -  
Code 33**

This code indicates when the signal voltage is high. The engine should not have a rough, unstable, or incorrect idle before this check. If so, correct it first.

Start with the ignition switch off to clear any codes. Do not connect any terminals on the ALDL. Start the engine and run for 1 minute or until the SES light comes on. Turn the key to the ignition on and engine stopped mode. Connect terminals A and B together. Note the code.

If the code is 33, turn the ignition off to clear the codes. Disconnect the MAP sensor electrical connector. Disconnect terminals A and B. Restart the engine and run for 1 minute or until the SES light comes on. Shut off the engine and turn the ignition on. Connect terminals A and B of the ALDL.

If code 33 is present, it means the signal circuit is shorted to the voltage side, or the ECM is bad.

If code 343 is present, check for a plugged or leaking sensor vacuum hose. If the vacuum hose is OK, there is an open in the sensor ground circuit or a faulty sensor.

**Map Sensor -  
Code 34**

This occurs when the signal voltage is low. Start with the ignition off to clear any codes. The ALDL A and B connectors are not jumpered. Start the engine and run for 1 minute or until the SES light comes on. With the engine off and the ignition on, connect A and B of the ALDL.

If a code 34 is found, turn the ignition off to clear the codes. Disconnect the MAP sensor and jumper the harness connector terminal B to C. Start the engine and run for 1 minute, or until the SES light is on. As usual, shut off the engine and turn on the ignition. Connect A to B on the ALDL and note the code. If the code is 33, replace the sensor.

If the code is 34, remove the jumper from terminal B to C of the harness. Check for voltage between the harness connector terminal A and C using the DMM. If the voltage reading is between 4 and 6 V, there may be an opening in the MAP signal circuit 432, a short to ground in circuit 432, or a faulty ECM connector or ECM.

# 8/TR

Troubleshooting

8/TR - ECM

Electronic Control Module

8/TR - ECM - CL

Code Listings

## Electronic Spark Timing Circuit - Code 42

If the voltage is below 4 V, there may be an open in the 5 V reference circuit 416, a short to ground in circuit 416, a short between circuit 455/469 and circuit 416, or a faulty ECM connector or ECM.

Begin with cleared codes. Idle the engine for about 1 minute or until the SES light comes on. With the engine off and the ignition on, connect A to B on the ALDL.

If code 42 is present, turn the ignition off and disconnect the ECM connectors. Turn the ignition on. Use the DMM in the ohms range to measure between 1000 and 2000  $\Omega$ . Check the ECM harness connector circuit 423 with the DMM and ground. It should have a reading of 500  $\Omega$  or less. If it does not, there is an open circuit 423, a faulty connection or faulty ignition module. Replace the defective component.

If there is a reading of 500  $\Omega$  or less, check the ECM harness connector circuit 424 with a test lamp connected to 12 V and note the reading.

If the test lamp is on, disconnect the ignition module 4-way connector and see how the light reacts. If the light stays on, the circuit 424 is shorted to ground. If the light goes off, there is a faulty ignition module.

If the lamp is off when checking circuit 424 with the test light, check the ECM harness again with the DMM to circuit 423 and ground. Reconnect the lamp to 424 and see if the ohms reading goes from under 500 to well over 5,000  $\Omega$ .

If the reading does not increase to greater than 5,000  $\Omega$ , disconnect the ignition 4-way connector and read the meter. The resistance should have gone high (an open circuit.) If so, there is a faulty connection or faulty ignition module. If not, circuit 423 is shorted to ground.

If the ohms reading climbed to over 5,000, reconnect the ECM and idle the engine for one minute or until the SES light comes on. If the light is on (code 42) there is a faulty ECM.

**8/TR**

Troubleshooting

---

8/TR - ECM

Electronic Control Module

---

8/TR - ECM - CL

Code Listings

---



**8/TR**

Troubleshooting

8/TR - PS

Power Systems

8/TR - PS - BS

Battery Systems

**8/TR - PS**  
**Power Systems****8/TR - PS - BS**  
**Battery Systems****Introduction**

The primary area to be checked before any others, must be the power section of the automobile. If the power section is not working, or is working improperly it could be caused by the battery or alternator system.

**Electrical  
Systems  
Diagnostic**

The battery is the main source of power for the automobile. Automobiles are based on a 12 VDC power system. The engine electrical system diagnosis includes checking the battery, charging system (generator and related wiring), cranking system (starter and related wiring), ignition system (distributor, spark plugs and wiring) and the glow plug system for diesel electrical systems.

**Basic Functions**

The battery has three basic functions in the electrical system. It provides the source of power needed for cranking the engine, acts as a voltage stabilizer for the electrical system, and can (for a limited time) provide the power needed when the electrical load used exceeds the output of the generator.

**Sealed Battery**

Most vehicles today use a sealed battery (or semi-sealed battery) in their electrical system. These batteries are intended to be maintenance free (or relatively so). The battery may have no filler caps in the cover - no openings at all except for a small vent hole. This vent allows small amounts of gases produced by the battery to escape. These gases can be explosive if exposed to open flames. Never check a battery using a lighter or other open flame as a light source. For the same reason, never smoke around a car battery, especially a charging one. (When charging, the level of these gases increases.)

**Hydrometer**

The tool used to test a battery is the hydrometer. This device has a green ball that rises or falls depending on the specific gravity of the electrolyte. If the ball shows in the viewing window, the charge of the battery is at 65% or greater.

If the battery is of the sealed-type, it may have a built-in hydrometer or other indicator. A green dot will be visible within the view window when the charge

**8/TR****Troubleshooting**

8/TR - PS

Power Systems

8/TR - PS - BS

Battery Systems

is 65% or more. If there is a dark green, or no visible color, the charge is below 65%. The battery should be charged until the green dot appears in the view window. (The battery may need to be shaken slightly to make the green ball appear).

If the indicator is clear or light yellow, it means the fluid level has dropped below the bottom of the hydrometer. This could be caused by a leaking broken case, the battery tipping beyond 45°, normal wear-out, or overcharging because of a problem in the electrical system. Check the system and/or replace the battery.

**Battery Ratings**

Batteries are rated according to their reserve capacity in minutes and their cold cranking power in amperes. Both of these methods involve measuring the battery terminal voltage after a specified time period and discharge current. The reserve capacity is the length of time it is possible to travel at night with the minimum electrical load and no generator output. It is expressed in minutes and refers to the time required for a fully charged 12-V battery at a specific temperature (80° F) to be discharged at a constant current (25 A) to reach a terminal voltage of 10.5 V. The cold cranking ampere test measures the amperage supplied by the battery at 0° F for 30 seconds.

**Checking the Battery**

The battery should be periodically checked (monthly) for obvious damage like cracked or broken casing or a cover that allows for leaking to occur. In the event there is leaking or cracking, the battery must be replaced.

**Electrolyte Levels**

In batteries that have fill holes and even in some maintenance free batteries, the levels of the electrolyte (water mixed with sulfuric acid) should be checked monthly, especially in warmer climates. The electrolyte levels in each of the six cells should be just above the metal plates, or slightly higher. Each cell of a battery supplies a little more than two V.

**Load Testing****Testing Procedure**

The battery should be disconnected from the automobile to do a load test. Install an adapter for screw terminal batteries (like the AC-Delco ST 1201 or equivalent), or use 3/8" bolts in the screw holes. Do not over tighten the screws—turn only until the screw does not turn anymore. Install a voltmeter and battery load tester to the adapters. Remove the surface charge of the battery by applying a 300-A load across the adapters for about 15 seconds. Turn the load off and wait 15 seconds for the battery to stabilize.

# 8/TR

Troubleshooting

8/TR - PS

Power Systems

8/TR - PS - BS

Battery Systems

Apply the specified load selected from the specifications chart for the battery and observe the battery voltage after 15 seconds with the load connected. Then, turn off the load. If the battery voltage does not drop below the minimum voltage as shown in the following list, the battery is good and can be returned to service.

## Minimum Voltage List

Temperature	Minimum Voltage
70° F & above	9.6 V
60° F	9.5 V
50° F	9.4 V
40° F	9.3 V
30° F	9.1 V
20° F	8.9 V
10° F	8.7 V
0° F	8.5 V

If the battery passes the load test, it is in good condition and no further testing is necessary. If it fails the load test, perform an open circuit voltage test to see whether the battery should be charged or replaced.

## Open Circuit Voltage Test

When the battery fails the load test, the state of charge will need to be checked. Open circuit or no load voltage is a good measurement of the charge after the battery has stabilized. This will take a couple of minutes of rest with open circuits after the load test has been completed.

The change of voltage with charge is small and most battery testers use special voltmeters with scales expanded to better show the percentage charged. If the charge is at 75% (12.4 V or more), the battery is considered charged and should not be charged further. If it failed the load test but has a 75% or better reading, the battery should be replaced. If it is under 75%, it should be charged and load tested again. If the load test fails again, the battery must be replaced.

Load testing and open circuit testing can be done by your local automotive parts dealer and is usually free. They can quickly determine if you need to replace or charge the battery. Often, they can quickly recharge your battery and redo the tests.

## Battery Recharging Procedures

### Warning!

*When batteries are being charged, an explosive gas mixture forms beneath the covers of each cell. Do NOT smoke near batteries on charge or which have recently been charged. A spark can occur where the live circuit is broken. All open flames must be kept away from the battery.*

**8/TR**

## Troubleshooting

8/TR - PS

Power Systems

8/TR - PS - BS

Battery Systems

**Safety Precautions** When you must charge a sealed battery, take the following safety precautions:

- Do not charge the battery if there is a green dot visible, except immediately following a prolonged cranking.
- Do not charge the battery if the hydrometer reading is light yellow. Replace the battery.
- If the battery feels hot (125° F), or if there are violent gases or a spewing of electrolyte through the vent holes occurs, discontinue charging immediately. This is an indication that an explosive condition is developing.
- Batteries should only be charged until the green dot appears in the hydrometer. A slight tipping or shaking of the battery may be necessary to make the green dot appear.
- For the best results, the batteries should be charged while the electrolyte and plates are at room temperature. A battery that is extremely cold may not accept current for several hours after starting the charger.
- Charge the battery until the green dot appears. Check the battery every half hour when charging.
- After charging, the battery should be load tested.

**Charging Time  
Required**

The time required to charge the battery depends on several things.

Battery charger outputs determine how long a completely discharged battery will take to charge. A one ampere current, for example, can take 72 hours or more to charge even a medium-sized battery that has completely discharged. (A larger battery may require as much as twice as long as a smaller battery.)

The temperature of a battery at 0° F will take longer to charge than a battery at 80° F. If a fast charger is connected to a cold battery, the current will be accepted more slowly at first, then will increase over time as the battery warms.

The state of the charge will depend upon how drained the battery really is. Electrolyte is nearly pure water and a poor conductor in a completely discharged battery, so current is accepted very slowly at first.

To charge a very low battery (or one that is completely discharged) the following steps should be taken. Failure to do so may cause charging damage and ruin what was a perfectly good battery.

**8/TR**  
Troubleshooting

8/TR - PS

Power Systems

8/TR - PS - BS

Battery Systems

**Charging  
Procedure**

Measure the voltage at the battery terminals with a DMM. If the voltage is 10 V or below, the charge current will be very low. It could take some time before the battery accepts a current in excess of a few milliamperes. Such low current may not be detectable on ammeters built into many chargers.

Set the battery charger on the highest setting (if it has one). Make sure that the polarity is correct. Some chargers feature polarity protection circuitry which will prevent charging unless the charge leads are connected to a battery's terminals correctly. A completely discharged battery may not be able to activate this circuitry so do not put your trust in it.

A completely discharged battery must be recharged for a sufficient number of ampere hours (AH) to restore it to a usable level. As a general rule of thumb, this may be calculated from the reserve capacity (RC) rating of the battery. For example if a battery has an RC of 75, and a 25 A charge is applied, the charge time becomes 3 hours.

After any battery charge with this method, it is best to perform a load test to ensure proper useability.

**8/TR**  
Troubleshooting

---

8/TR - PS

Power Systems

---

8/TR - PS - BS

Battery Systems

---

## 8/TR - PS

### Power Systems

## 8/TR - PS - CS

### Charging Systems

#### Introduction

The charging system consists of the battery, the generator (or alternator), the regulator, and the charging system indicator lamp. The generator/alternator supplies the electrical power required for charging the battery and operating the accessories of the vehicle.

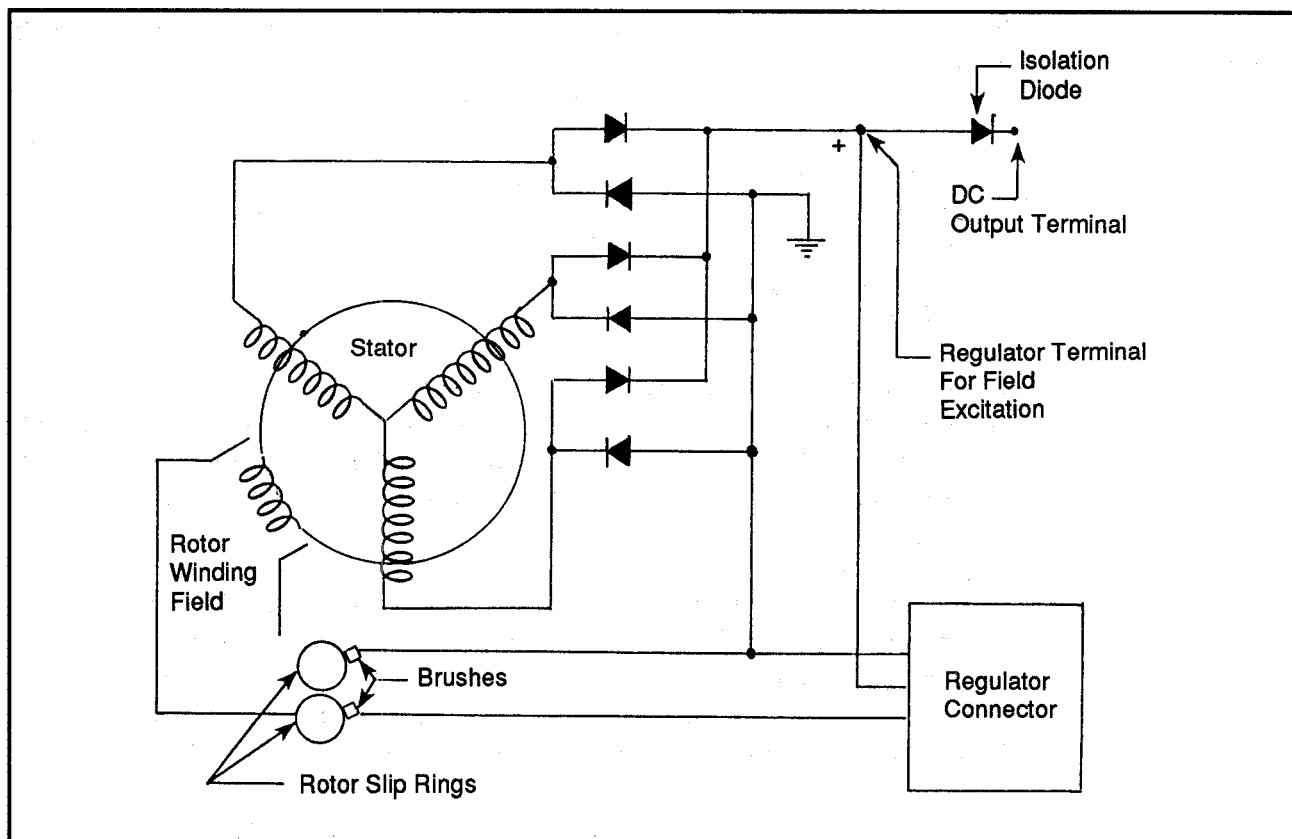
With many charging systems, the voltage regulator is a separate unit. With others, such as most GM-based generators, the regulator is integral (built-in). In the latter case, if the regulator malfunctions, the generator will need to be replaced as a whole. Figure 1 shows a typical generator. It is controlled by a conventional fan and pulley system in the automobile. There is an internal fan cooling system, rectifier bridge and regulator system.

The regulator voltage settings vary with temperature, and limit the voltage by controlling the rotor field current. The regulator switches the rotor field current on and off at a fixed frequency of about 400 cycles per second. By varying the on/off time, a correct average field current for proper system voltage control is obtained.

The charge indicator is usually found on the instrument panel as a battery symbol. This display will light when the ignition is first switched on and goes out when the engine is running. If the charge indicator is on with the engine running, a charging system problem is indicated. The indicator will glow at full brilliance if any charging problem occurs or if the system voltage is too high or too low.

#### Noisy Generator

Noise from a generator may be caused by a loose drive pulley, belt, mounting bolts, worn or dirty bearings, or a worn stator. If the pulley, belt and mounting bolts are snug, yet the noise continues, the generator will need to be replaced. This is usually a simple matter of unplugging the connectors, loosening the mounting bolts, and installing the new generator by reversing the steps.



**Figure 1:** Typical generator

### Testing the Generator

The wiring and generator belts must be working properly before making any test on the generator. Also, the battery should be fully charged and connected properly. To avoid damage to the vehicle's electrical system:

- Do not polarize the generator.
- Do not short across or ground any of the terminals in the charging circuit except as specified in any instructions.
- Never operate the generator with the output terminals disconnected.
- Make sure the generator and battery have the same ground polarity.
- When connecting a charger or booster battery to the vehicle battery, connect negative to negative and positive to positive. Also, when charging a battery, remove one lead of the battery from the system to avoid generator damage.



**Trouble Indication**

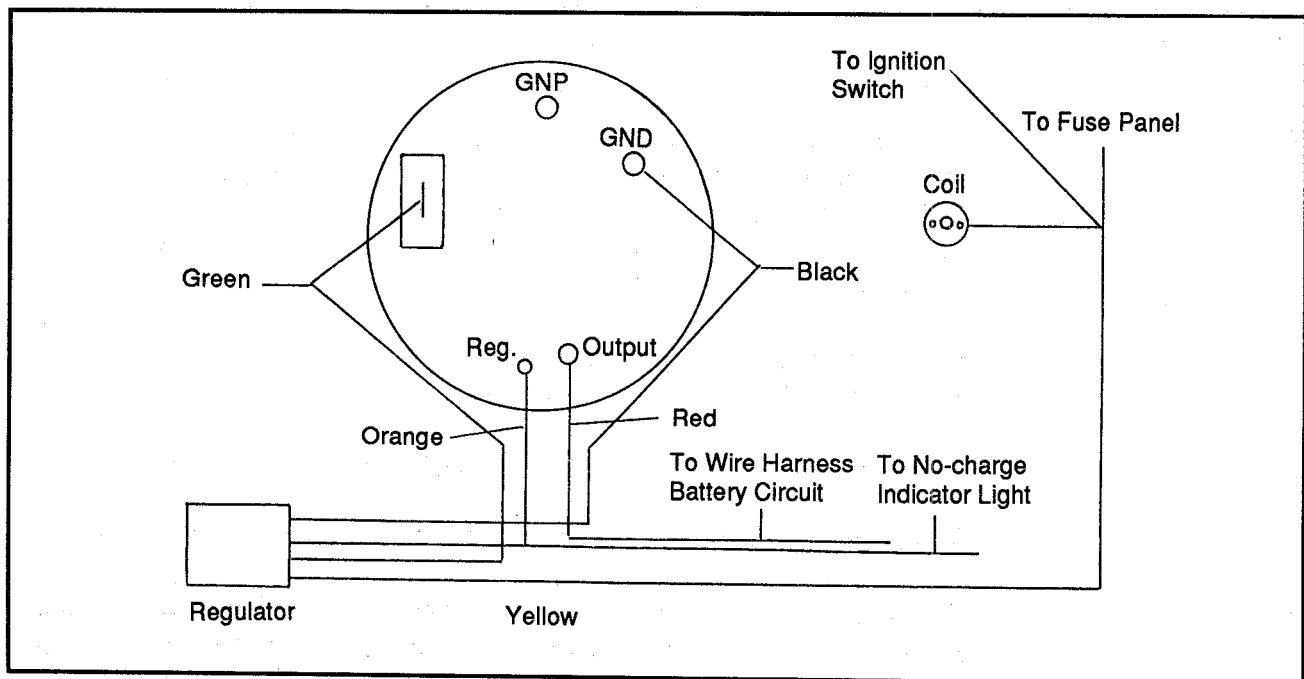
Trouble in the charging system will show up as one or more of the following conditions:

- Abnormal indicator lamp operation.
- An overcharged battery which may be spewing electrolyte from the vents.
- An undercharged battery as indicated by the hydrometer readings, poor starting and other symptoms.

A basic wiring diagram for a charging system is shown in Figure 2. When the generator operates normally, the vehicle battery lamp will only be on when the automobile is started and then go out. An undercharged battery is often a sign that some accessory has been left on for a period of time. Check this out before wasting time testing the system.

**Visual Inspection**

Testing of the generator first begins with a visual inspection of the belt for wear and proper tension. The service manual will designate the proper tension required, but will typically not have more play than a quarter of an inch in either direction. An electrical test and load test of the generator can easily be performed by your local automotive parts dealer and will cost little or nothing.



**Figure 2:** Generator wiring diagram

**8/TR****Troubleshooting**

8/TR - PS

Power Systems

8/TR - PS - CS

Charging Systems

**Battery  
Lamp "ON"**

With the ignition switch on and the engine stopped, the battery lamp should be on (in systems with an indicator lamp). If the indicator fails to light, detach the wiring harness at the generator and ground the "L" terminal lead. If the lamp lights, replace the generator. If the lamp does not light, locate the open circuit or replace the lamp.

**Battery  
Lamp "OFF"**

With the ignition switch on and the engine running at a moderate speed, the lamp should be off. If not, detach the wiring harness at the generator. If the lamp goes out, replace the generator. If the lamp stays on, check for a grounded "L" terminal wire in the harness.

**Battery  
Undercharged/  
Overcharged**

If the battery is undercharged or overcharged, detach the wiring harness connector from the generator. With the switch on and the engine not running, connect the DMM from ground to the "L" terminal of the wiring harness, and to the "I" terminal (if used). A zero reading indicates an open circuit between the terminal and the battery. Correct as required.

Connect the harness connector to the generator and run the engine at a moderate speed with all the accessories turned off. Measure the voltage across the battery. The reading should be above 16 V. If not, replace the generator.

Connect an ammeter at the generator output terminal and turn on the accessories. Load the battery with a carbon pile to obtain a maximum current draw. The voltage reading should still be continuous at 13 V or above. If it isn't, or if the current output (in amperes) of the generator is lower than the full-load rating, replace the generator.

This concludes the battery and charging system checks. These checks should always be done before continuing with any other electrical problem tracing in automobiles. Most systems are dependent on a good working battery and generator/alternator. If these are bad, they must be fixed or replaced before proceeding with any other steps.

## **8/TR**

### **Troubleshooting and Repair**

---

## **8/TR - R**

### **Radios in Automobiles**

---

#### **Introduction**

Most radio repairs will be found in the radio portion of this manual. The operation, testing and repair of the automotive radio differs from a home-based radio only in that the car radio is powered directly from the car's 12 VDC system whereas the home radio will generally have a power supply to convert the 110 VAC into the needed DC. In this section we shall confine ourselves to those radio problems that are related to the automobile.

The automobile radio can be affected by many external problems that are not in the radio itself. These range from antenna problems to interference from various other sections of the vehicle. This means, simply, that testing the radio includes more than just testing the radio itself.

Noise in reception can indicate that there is a faulty high energy ignition system. Most noise will be found on weak AM stations near the low frequency end of the band. (Weak or fading AM is often caused by an improperly adjusted antenna trimmer.) About 90% of the noise enters through the antenna. If a test antenna is used, the base should be grounded to the car's body. Do not hold the antenna with your hand as this makes you a part of the antenna.

#### **Blower Motor Noise**

A blower motor can cause annoying distortion or popping in radio signals. A common method of reducing or eliminating this problem is to shunt any AC (including RF) from the motor and ground through a capacitor. A diode (1N4001 or equivalent) is used to avoid high-speed blower relay popping. This is connected from the high-speed switch wire to ground on the high-speed blower relay under the hood. Find these two components and test them if you suspect that they may be causing the problem.

#### **Cruise Control Pop**

As it engages and disengages, the cruise control can cause popping. Install a 0.5  $\mu$ F capacitor rated at 50 VDC from the hold line at the transducer to ground. If the pops are still present, splice a 0.5 mF cap across the contacts of the disengage switch at the brake pedal.

**8/TR****Troubleshooting**

8/TR - R

Radios in Automobiles

**Brake Switch Pop**

A 0.5 mF capacitor between the two wires going to the brake switch at the brake pedal may be needed to avoid brake switch pop. An additional 0.5 mF cap can be connected from the 12 V lead to ground at the brake switch.

**Diesel Engine Noise**

A clicking or popping similar to ignition noise can occur in diesel engines. The sound will not vary with engine speed as will ignition noise. If present, this noise will be most noticeable while the engine is idling.

The noise is generated by the high vacuum switch in the EGR assembly. Check the system for any vacuum leaks. Make any necessary repairs. If the noise is still present, change the EGR control assembly.

**Horn Noise in Radio**

If there is interference when the horn is blown, install shunt capacitors between each horn lead and chassis ground. Place these as close to the horn as possible.

**Rear Defogger Noise or Hash**

If there is a broken grid in the rear window defogger, the result may be a "hash" in the radio. Repairing this break will eliminate the problem. (This may involve replacing the rear window, or could be as simple as repairing a connector.) A break in the grid can be found by turning the defogger on. Touch each of the grid lines until a cold one is found. This will be the bad line.

**Torque Converter Lock-up Noise**

Diesel engines can cause hash or a popping noise on AM bands after the torque converter "lock-up." This occurs at about 35 to 45 MPH. To correct the problem, install a filter package in series with the green lead on the VRV switch as prescribed in the filter package.

**Miscellaneous Noises**

Any motor and many switches can be the source of radio noise. In most cases the noise can be eliminated by installing a 0.5 mF capacitor rated at 50 VDC across each motor. Installation of a 0.5 mF capacitor across the contacts of suspected switches may also solve the problem. Once again, the idea is to shunt any AC (including RF) to ground. The capacitor is an open circuit to DC (DC can't flow through the capacitor) but a virtual dead short to AC. Because of this, unwanted AC in the wires that could be picked up as noise by the antenna will be sent to ground.

An antenna sniffer to find "hot spots" can be made to locate popping problems. This consists of an antenna (an old one will do) attached to a fairly long piece of antenna wire (coax). The antenna part should have some kind of insulated handle so that your hand doesn't touch the antenna while testing.

Disconnect the original antenna and plug the sniffer into the antenna socket. Turn the radio volume up. Check wires with the sniffer parallel to the suspected wire.

**8/VCS**Various Case  
Studies

8/VCS - GM	General Motors
8/VCS - GM - CKPT	CK Pickup Truck

## 8/VCS - GM

### General Motors

## 8/VCS - GM - CKPT

### CK Pickup Truck

#### Introduction

This section is a case study on various repairs specific to the electronic componentry of a CK light duty pick-up truck. These trucks are part of the GM line of mid- to full-size pick-ups. Many of these trucks have all the comfort of a car with the power needed of a truck.

#### Computer Controller

The computer controller is the center of these vehicles. So much depends on the electronic control module (ECM) that, if there is a malfunction, performance of the vehicle can drop quickly and dramatically. This is why the ECM must be at peak performance. The ECM controls the handling of so many of the truck's systems, that it is easy to become lost in the problems and symptoms being reported. The interconnection between the modules and sensors—all with the ECM serving as a “clearing house”—can make troubleshooting frustrating at times.

Much of the information discussed in the Section “8/TR” applies. For example, all of the various sensors and pin assignments described are correct for this vehicle. It is suggested that you read the section first for a broad overview.

You should also note that the following information not only applies to virtually every CK pickup, regardless of year, but much of it applies to other vehicles as well. As always, it is our goal to select case studies which are specific, yet which simultaneously have broader value. If you need even more specific information on the CK line, some very large (800+ pages) manuals are available which include complete wiring diagrams.

#### The GM Electronic Control Module

#### Location

As with most vehicles using an onboard computer, the electronic control module in the CK is located in the passenger compartment of the truck. You will find it

8/VCS - GM	General Motors
8/VCS - GM - CKPT	CK Pickup Truck

above the heater and air conditioning motor on the passenger side of the vehicle. It is the control center for the computer command control system.

## PROM

There is a removable PROM in the top of the ECM. This PROM can be changed to match the specific vehicle. This PROM has specific program information for an engine and vehicle, up to and including the vehicle's weight, engine size and type, kind of transmission, axle ratio and several other items used by the ECM.

The PROM also contains a CalPak which contains specific calibration information. The CalPak allows the vehicle to operate if the ECM becomes damaged. It allows fuel delivery to occur. If the CalPak is not present, it will result in a no start and run condition of the engine.

The use of a universal ECM and a specific-program PROM allows the use of a single type of ECM for a wide variety of makes and models.

## "Learning Capability"

The ECM is capable of "learning" about the vehicle to make corrections for minor variations in the fuel system or to improve driveability. This learning process is erased if the battery is removed or disconnected. The learning must then be redone.

The ECM uses ICs called quad drivers (QDRs) in place of separate transistors to turn ON and OFF different circuits controlled by the ECM. Each QDR has four separate outputs that can independently turn the four different circuits ON and OFF.

The ECM found in many trucks with the V6 and V8 engines does not incorporate fault protection. If a single faulty circuit occurs many times, it causes the QDR outputs to be inoperative or ON all the time. If the QDR fails, it causes either a short or open ECM output.

## Test Equipment

In addition to the test equipment mentioned in Section "8/TE" on automotive electronics there are a few more items recommended for servicing GM trucks.

- A vacuum pump that has a minimum of 20 inches of Mercury is required. The gauge is used to monitor the manifold engine vacuum. The hand pump can check vacuum sensors, solenoids and valves.
- A tachometer that is the inductive trigger signal pickup type will be required for some tests. It is used to check the revolutions per minute (rpm) of the vehicle.



8/VCS - GM	General Motors
8/VCS - GM - CKPT	CK Pickup Truck

- A connector test adapter kit is used to make electrical test connections in current weather pack, metripack and micropack style connectors.
- An oxygen sensor wrench is used to remove or install the oxygen sensor.
- An idle air control (IAC) wrench is used to remove or install the IAC valve on the throttle body.
- The injector test light is used to check electrical circuits to a TBI fuel injector system. There are two models available for the CK series truck: the TBI 220 and the TBI 700.
- Various terminal removers will be needed. A metripack, weather pack, and ECM terminal removers will be used.
- A fuel pressure gauge is used to check and monitor the fuel line pressure. These are available in a wide variety of styles.
- An ignition module tester is used to test the various sections of the ignition module.

## Troubleshooting

### No "Service Engine Soon" Light

Whenever the ignition switch is turned to the ON position and the engine is not running, the "Service Engine Soon" (SES) light should be on. There should be a voltage applied to the light by the ignition switch. The ECM controls the light and turns it on by completing the circuit to ground through circuit 419.

If the light refuses to go on, but you can start the engine, the ECM could be bad. Disconnect the ECM connectors and turn the ignition ON. Connect a test lamp between circuit 419 and ground. The SES light should be on. If it is, the ECM may be bad or the connection to it faulty.

If the light is not on at this stage, check to see that the gauge fuse and the bulb are good. If they are, check to see if there is an open circuit 419 (brown with white) or shorted 419 to voltage or an open ignition feed to the bulb.

If the engine does not start, there may be a continuous battery fuse or fusible link open. It is also possible that the ECM ignition fuse is open, that the battery circuit 340 (orange wire) to the ECM is open, that the ignition circuit 439 (pink with black wire) to the ECM is open, or there may be a poor connection to the ECM.





**8/VCS**Various Case  
Studies

8/VCS - GM

General Motors

8/VCS - GM - CKPT

CK Pickup Truck

2.5 V at a closed throttle, you have found an error code 21, which means that the signal voltage is high.

If the coolant is below  $-30^{\circ}\text{C}$  (code 15, which is the coolant sensor giving you a low temperature indication) turn the ignition off for 10 seconds and then back on. You should hear the fuel pump running. If there are two tanks, selecting each tank will start the fuel pump for the selected tank. They should run when selected. If not, the fuel pump relay circuit may need to be repaired.

Disconnect one of the spark plug wires and install a spark plug tester (ST 125 or equivalent). Crank the engine and check for a spark. If there is no spark, check the ignition system and repair. (Don't forget that you would be getting a false result if by coincidence the plug you selected happens to be bad. This is fairly unlikely but is possible.)

If there is a spark, reconnect the spark plug wire and disconnect the injector connectors. Crank the engine and see if there is spray from one or both of the injectors. If so, the injector seal may be faulty or the injector is bad.

If not, connect an injector test light to one of the harness connectors. Crank the engine and test both of the harness connectors. The test light should blink on both tests. If it doesn't, the injector circuits will need to be repaired.

If the test light blinks, reconnect the injector connectors and crank the engine. If there is fuel spray from the injectors there is no problem with the injectors. If only one works, the one that doesn't is faulty. If neither works, turn the ignition off and install a fuel pressure gauge as specified in the system pressure test section of the automobile repair manual. Turn the ignition on and see that the fuel pressure is at 62-92 kPa (9 to 13 psi). If it is—yet the injectors fail to spray—the injectors are faulty and should be replaced. If the pressure is below the listed range, the fuel system should be thoroughly checked.

**Injector Problem**

If there was found to be an injector problem, it will be necessary to determine if the ignition module is generating the required reference pulse, or if the wiring is at fault, or the ECM is bad. Figure 2 shows the area for which these tests apply.

A test light should be touched and removed between 12 V and circuit 430 (purple with white). If the injector test light blinks, the ECM and wiring are OK. The test light should blink each time the connection is removed.

If the injector light blinks, it indicates there is a bad ignition module or connection. If not, there may be an open or grounded circuit 430, or a bad

**8/VCS**Various Case  
Studies

8/VCS - GM

General Motors

8/VCS - GM - CKPT

CK Pickup Truck

connection at the ECM connector terminal “B5”. If all checks out good, turn the ignition on and probe each injector harness connection terminal with a test light to ground. If the light is on for both the terminals, repair the short to voltage that can be found at circuits 467 (light blue) and 468 (light green). If the light is off for both terminals, repair the open ignition circuit 481 (white) or 482 (red).

If the light is on for one terminal and not the other, turn the ignition off and reconnect the injector connector. Disconnect the 32 pin ECM connector and turn the ignition back on. Probe the connector terminal D14 or D16 with a test lamp to ground. If the light is on, there is a bad ECM connection D14 or D16 or a bad ECM. If the light is off, there is a bad connection or an open circuit 467 or 468.

**Fuel Pump Relay  
Circuits**

This part is valid for the C, G, K, P, R, and V series trucks. When the ignition switch is turned on, the ECM turns on the intake fuel pump. The pump stays on as long as the engine is cranking or running and the ECM is receiving the distributor reference pulses. If the pulses are not present, the ECM will turn off the fuel pump within two seconds after the ignition has been turned on, or when the engine stops. The pump delivers fuel to the throttle body injection unit (TBI) where the system pressure is kept to between 62 and 90 kPa (9 to 13 PSI). Any excess fuel is returned to the fuel tank.

This type of fuel control does not apply for those vehicles that use a fuel module. Fuel modules are used on 7.4 liter, G series vans with 5.7 liters, and all other 5.7 liter engines over 8500 GVW (Gross Vehicle Weight). These fuel modules are used to correct a hot restart (vapor lock) during high ambient conditions. They will override the ECM two-second pump operation and will run the fuel pump for 20 seconds when the ignition is switched on.

Connect a fused 12 V power lead to the fuel pump test terminal (circuit wire 490—red) of the fuel pump relay. This will cause the pump to run. If it doesn't, the fuel relay may be bad. If the pump does not run, check for an open circuit 120 and 920, the relay, circuit 150 or for a bad fuel pump.

If the pump does run, remove the 12 V test lead from the test terminal. Turn the ignition off for about 10 seconds. Disconnect the fuel module and turn the ignition on. Listen for the in-tank fuel pump to be running. The pump will run for two seconds and then shut off. If the pump runs, there is no problem with the fuel pump, but there may be a problem with the fuel module.

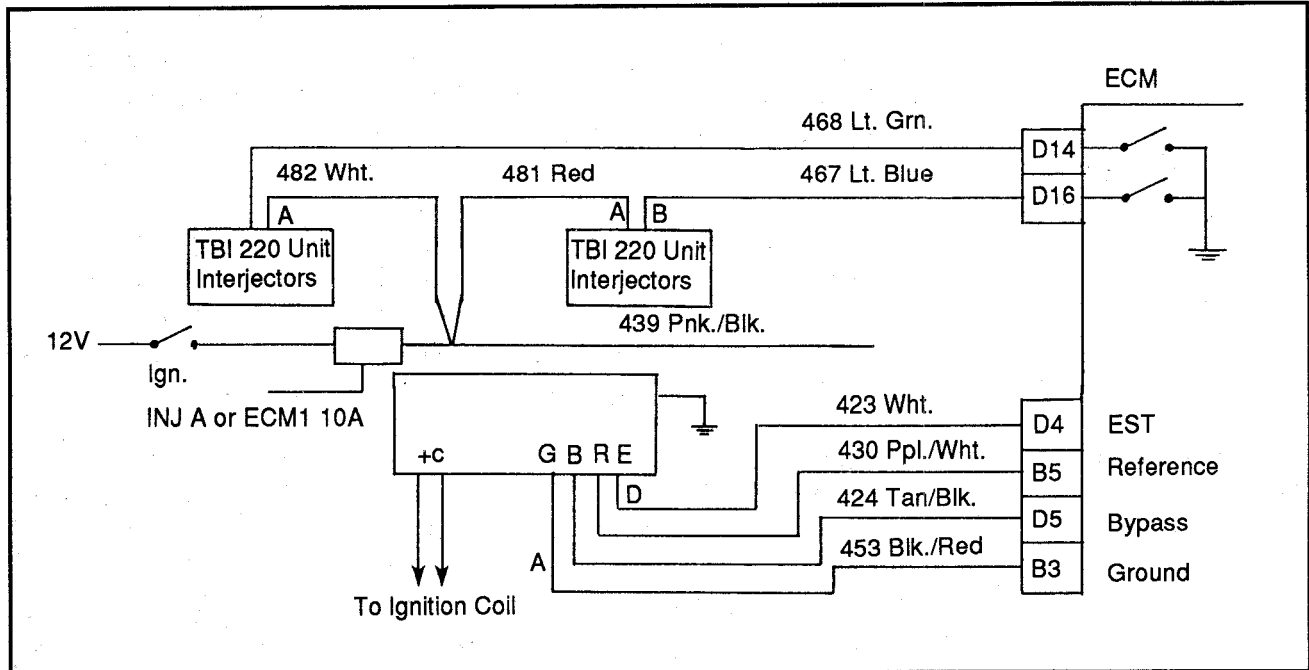
If the pump does not run, disconnect the pump relay. Turn the ignition on with the engine stopped. Probe the relay harness connector terminal circuit 440

# 8/VCS

Various Case Studies

8/VCS - GM  
8/VCS - GM - CKPT

General Motors  
CK Pickup Truck



**Figure 2:** Injector diagnoses circuit points

(orange wire) with a test light connected to ground. If the light is off, fix the bad circuit 440.

If the light is on, connect a test light between the harness connector and terminal circuits 450 (black with white wire) and 440 (orange wire). If the light is off, repair the bad wire 450.

If the light was on, connect the test lamp between terminal 465 (ECM A1—dark green and white wire) and ground. Turn the ignition off for 10 seconds and then back on. The light should light for two seconds, and then go off. If it does not, check for a short in wire 465 or a bad ECM.

If it does, there may be a bad connection at the relay terminal D or a bad relay. Connect the fuel module if removed and see if the original symptoms continue (engine cranks but will not run). If the symptoms continue, there is probably a bad fuel pump, or bad connections to it.

## Fuel System Pressure Check

When the fuel pump is running, fuel is sent to the injectors and then to the regulator where the pressure is controlled to between 62 and 90 kPa (9 to 13 PSI). Any excess fuel is returned to the fuel tank.

# 8/VCS

Various Case Studies

8/VCS - GM	General Motors
8/VCS - GM - CKPT	CK Pickup Truck

Begin the test with the ignition off. Install a fuel pressure gauge as described in the vehicle service manual. Turn the ignition on and note the pressure that occurs within the first two seconds. The fuel pressure should be between 62 and 90 kPa (9 to 13 PSI). If it is, there is no problem.

If the pressure is below 62 kPa, install a pressure gauge on the inlet side of the fuel filter and reinstall the filter outlet line. Connect 12 volts to the test terminal and note the pressure. If it is above 62 kPa, replace the filter and check again from the beginning. (This means that the filter is probably clogged.)

If the pressure is less than 62 kPa, turn the ignition off and disconnect the injector. Block the fuel return line by pinching the flexible hose. Apply 12 volts to the fuel pump test connector and note the pressure. If it is above 89 kPa (13 PSI), the TBI fuel pressure regulator assembly may need to be changed. If the pressure is below 62 kPa, check for restricted fuel lines from the tank, a bad gauge or fuel pump, coupling hose, inlet filter, or wrong fuel pump.

## Ignition System

The ignition system includes the battery, distributor, engine control switch, spark plugs and the primary and secondary wiring systems.

The distributor for these trucks is used with a separate coil system. The coil connects to the rotor through a high tension wire. The primary voltage in this system is 35,000 V and is induced into the ignition coil secondary winding by the primary winding which is controlled by the ECM.

The electronic spark timing system (EST) is a part of the ECM. The ECM monitors various engine sensors, computes the desirable spark timing, and then tells the distributor to change the timing accordingly. The ignition system controls the fuel combustion by providing a spark to ignite the compressed air and fuel mixture at the correct time.

If the ECM is not receiving the engine RPM reference signal, a code 12 will be produced on the scan tool, or the SES light when hooked to do so. The reference signal also triggers the fuel injection system. Where there is no reference signal, the engine will not run.

## Electronic Spark Control (ESC)

The ESC is designed to inhibit spark timing up to 20° to reduce the amount of spark knock in the engine. This allows for a more efficient use of fuel and produces better driveability. This device is found on all engines except the 2.5 l and the 7.4 l.

The ESC is composed of the ESC module, the ESC knock sensor and the ECM.

8/VCS - GM	General Motors
8/VCS - GM - CKPT	CK Pickup Truck

All three must be working together for the vehicle to perform at the maximum possible state.

The ESC knock sensor detects any abnormal vibration (spark knocking) that may occur in the engine. The sensor is mounted in the engine near the cylinders. The ESC module receives information from this sensor and then adjusts the electronic spark timing (EST) to cut back on any spark knocking.

The ESC module sends a voltage signal (between 8 and 10 V) to the ECM. If no spark knocking is sensed, the ECM will provide a normal spark advance. If a spark knock is sensed, the knock sensor will shut down and not send a signal to the ECM. This reduces the EST which in turn retards the spark knock.

If the ESC knock sensor were to fail, there could be heavy knocking because the ECM would remain at a high state. The ECM would assume there is no problem and continue to keep the EST at a constant level which may be too high or low. Severe knocking would be present.

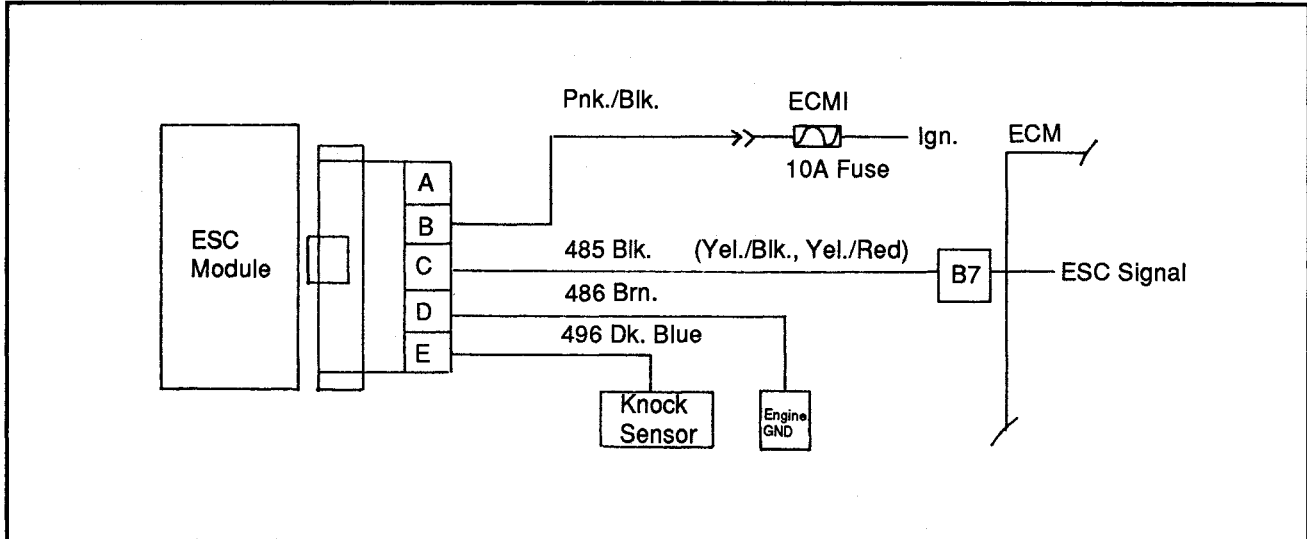
A code 43 indicates that the ECM is receiving less than the required 6 V for a four second period with the engine running. If the code is present the knock sensor may need to be replaced.

To begin checking or repairing the ESC knock sensor, you will find it on the lower left side and below the spark plugs for the 4.3 liter engine block. For 2.8 L, 5.0 L and 5.7 L engines it will be located on the lower right of the engine block.

Figure 3 shows the wiring for the knock sensor and ESC module. There should be no knock signal present in the ECM until the engine is running at about 1500 rpm. If there is a knock sensor code 43 present, disconnect the knock sensor. Repeat the test. The code should disappear. If it does, this is an indication that there is a bad sensor. If the code remains, check at the routing of the wires from the knock sensor to the ESC module. There may be a short or other problem causing the code to appear.

A simple test to see if the knock sensor is OK is to tap on the engine near the knock sensor while the engine is running at about 1500 rpm. If the code 43 becomes evident it shows the sensor is working well.

If not, the ESC module should be disconnected. Then, probe the harness terminal D (circuit wire 486 - brown) with a test light connected to 12 V. If the light is off, circuit 486 is bad and should be fixed.



**Figure 3:** Knock sensor and ESC module wiring

If the light is on, reconnect the ESC module and disconnect the knock sensor. Idle the engine. Touch a test light to the circuit wire 496 and 12 V for just a moment. Each time the test light comes in contact with the wire and 12 V a knock signal should be generated and read on the scan tool. If so, the connection at the sensor is bad, or the sensor is bad. If not, circuit 496 (dark blue) is open, or shorted to ground and should be fixed. There may be a bad connection at the ESC module or a bad ESC module.

### Lean Exhaust Sensor

A voltage of about .45 V is applied by the ECM across terminals D6 and D7. These control the oxygen sensor. If a 10 M $\Omega$  DMM meter is used to measure this, the reading may be as low as .32 V.

The oxygen sensor varies the voltage within a range of about 1 V if the exhaust is correct, and reduces to about .10 V if the exhaust is too lean. The sensor acts like an open circuit and creates no voltage when the temperature is below 600° F for the area surrounding the sensor.

The engine should be run and warmed at about 1200 rpm. If there is a code 44 present, disconnect the O<sub>2</sub> sensor. With the engine at idle, the scan code 44 should remain and the voltage should be between .35 and .55 V. If so, the sensor may be bad, or one of the following conditions exists:

It is possible that there is a small amount of water near the in-tank fuel pump inlet which is being picked up and sent to the injectors. The water can cause a lean exhaust and set a code 44.

**8/VCS**Various Case  
Studies

8/VCS - GM

General Motors

8/VCS - GM - CKPT

CK Pickup Truck

The reading could be caused by too little fuel pressure in the system. It may be necessary to check the fuel pressure while driving the vehicle at various speeds and/or loads to confirm the problem.

The circuit 413 (tan) may be open in which case the voltage at D7 will be over 1 V.

The sensor harness pigtail may be mispositioned and in some way in contact with the exhaust manifold.

There may be an intermittent ground in the wire between the connector and the sensor.

If all else checks out OK, the oxygen sensor is bad and should be replaced. It may be best to replace it and see if other problems go away as well.

**Park/Neutral  
Switch Sensor**

The park/neutral switch is closed when the vehicle is in park or neutral. The contacts for the switch are grounded at this point. The ECM supplies an ignition voltage through a current limiting resistor to circuit 434 (orange with black) and senses a closed switch when the voltage on circuit 434 drops to less than 1 V. The ECM uses the P/N signal to control the idle air control, the VSS diagnostics and the EGR.

With the transmission in park or neutral, the scan device should indicate a park or neutral state. If so, the transmission can be switched to drive and the scan tool read. The scan tool should change states to indicate drive. If not, disconnect the P/N switch. The scan switch should display a drive range. If not, circuit 434 may be shorted to ground or there is a bad ECM. If so, the P/N switch is misadjusted or bad.

If, when the transmission is in park or neutral, the scan does not indicate a park or neutral, disconnect the P/N switch connector. Jumper terminals A to B (circuit 434 to 450—black and white). The scan should indicate park or neutral. If it does then the P/N switch or connection is bad or misadjusted.

If not, jumper terminal A (circuit 434) to the engine ground. The scan tool should indicate a park or neutral. If so, there is an open ground to circuit 450. If not, circuit 434 is open or bad, or the ECM connection or ECM is bad.

**Power Steering  
Pressure Switch**

The power steering pressure (P/S) switch is normally open to ground. Circuit 495 (ECM C8 terminal—light blue with orange) will be near the battery voltage level. Closing the switch causes circuit 495 to read less than 1 V. The ECM will increase the idle air rate and retard the timing at this point.

# 8/VCS

Various Case Studies

8/VCS - GM	General Motors
8/VCS - GM - CKPT	CK Pickup Truck

Disconnect the P/S pressure switch connector. Turn the ignition on with the engine stopped. Check the voltage between the harness terminals circuits 450 (black with white) and 495. There should be a battery voltage reading.

If there is not, probe each terminal with a DMM, between terminal and ground, and note the voltage. Check for battery voltage on one of the terminals. If found, repair the grounded circuit 450. If no battery voltage can be found, disconnect C-D, the ECM connector, and check for an open or short to ground in circuit 495. If it is OK, there is a bad connector or bad ECM.

If probing circuits 450 and 495 did reveal a battery voltage, connect the ohmmeter between the switch terminals. The resistance should be high to indicate an open switch. If it's not, the power steering switch is bad.

## Air Conditioning

Section 8/TR - ECM gives examples for when the ECM is not functioning properly for the vehicle. As you can see, if the ECM is not working properly, there may be a wide variety of problems in the vehicle. This part covers a different type of system with its own separate CPU.

Figure 4 shows the block diagram of the air conditioning unit in model C and K trucks equipped with air. These vehicles use the new electronic control system to provide comfort control.

A CPU controls all the functions related to the air conditioner system. It controls the motors that operate the mode door, temperature door, air inlet and a variety of relays to control the blower motor speed and the compressor clutch operation. The display for the air conditioning system is a vacuum fluorescent unit which can indicate the air delivery mode, the temperature and blower speed.

There are six buttons to control the modes of the A/C unit. These are the A/C, heater/defrost, blower system off and temperature buttons. All of these controls make the CPU operate the various motors and relays, and with a feedback system from the various sections, can provide an accurate environment.

## Control Door Motor

There are three control door motors and control doors to be found in the vehicle A/C system. These are the mode section, the temperature section, and the air inlet. Each of these is wired to the CPU and controlled by it.

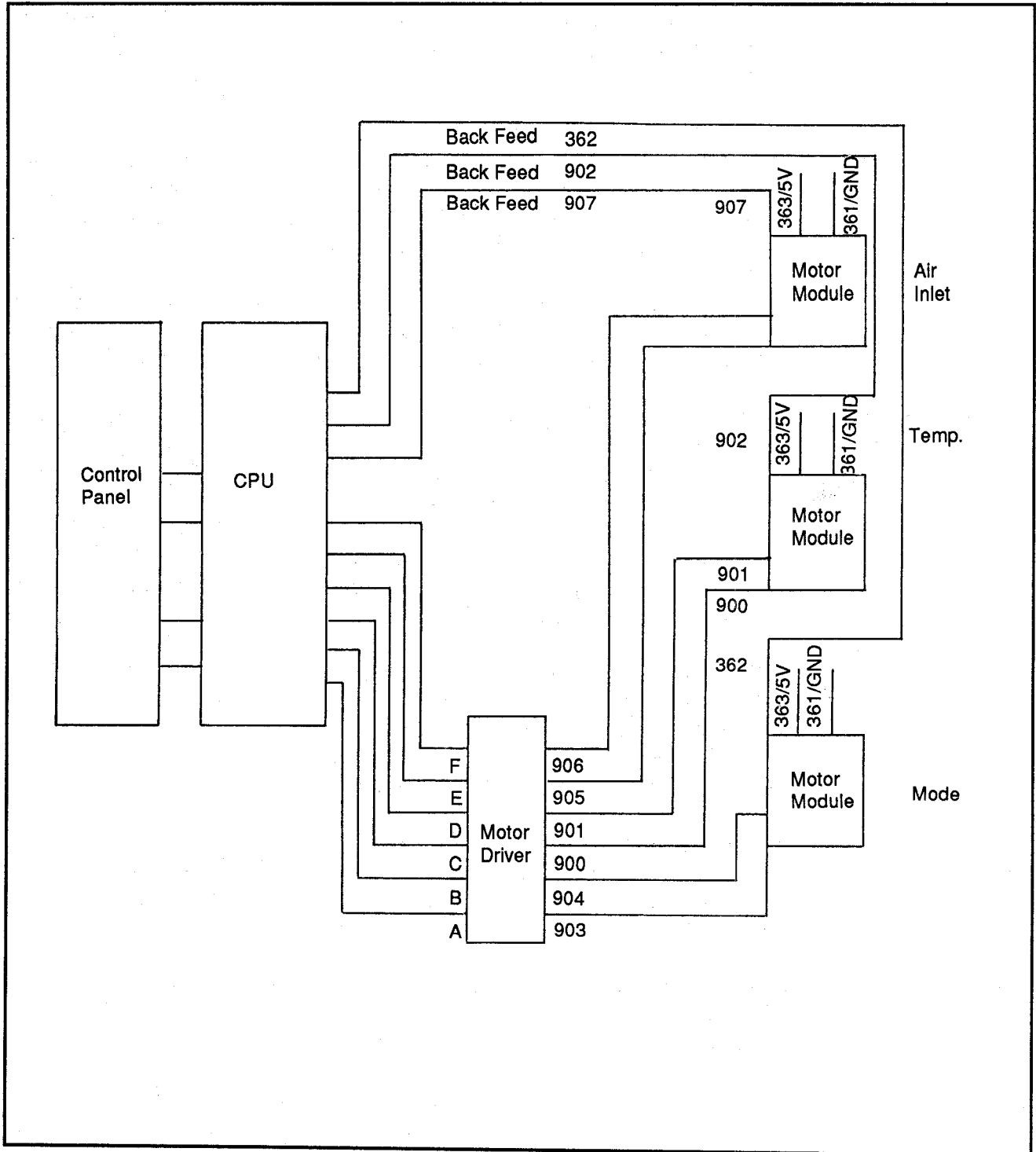
The motors used to control these doors are reduction gear motors. Each can rotate in either direction to position the door and control the amount of air flow. These motors are the permanent magnet type and use a feedback potentiometer to indicate the exact door position.



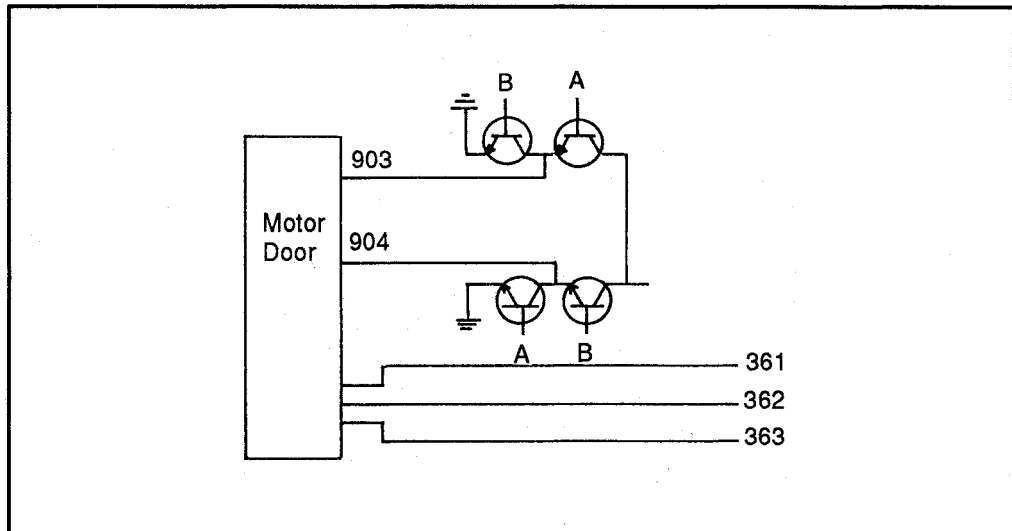
**8/VCS**  
 Various Case  
 Studies

8/VCS - GM  
 8/VCS - GM - CKPT

General Motors  
 CK Pickup Truck



**Figure 4:** Block diagram of the air conditioning section



**Figure 5:** Control door actuator section

Positioning of the motors is controlled by a series of “H” gate transistors. When two of the four transistors (A transistors) are forward-biased, the motor operates in a forward direction. When the other two transistors (B transistors) are activated, the motor is reversed. Figure 5 shows the control door actuator section.

### Blower and Control Clutch

There are three relays that control the A/C clutch and the blower motor. These relays respond to the output from the control panel relay driver.

To activate the blower motor, the CPU sends a signal to the relay driver. The relay driver activates one or more of the relays as needed to set the selected blower speed or engages the compressor clutch. The relays receive power from circuit 50 which originates in the control head. By activating one or the other relay, or both relays, the high, medium and low speeds can be selected.

The control head is what controls the operation of the two blower relays to send current through or bypass the blower resistors depending upon the speed selected. The control head also operates the A/C relay which starts the compressor.

When both relays are activated, current passes through both resistors in series to achieve a low speed. When the low blower relay is activated, the second resistor is bypassed and causes the blower to be at a medium speed. When the HI blower relay is activated, both of the resistors are bypassed and the motor runs at a high speed. Figure 6 shows the blower motor relay wiring.

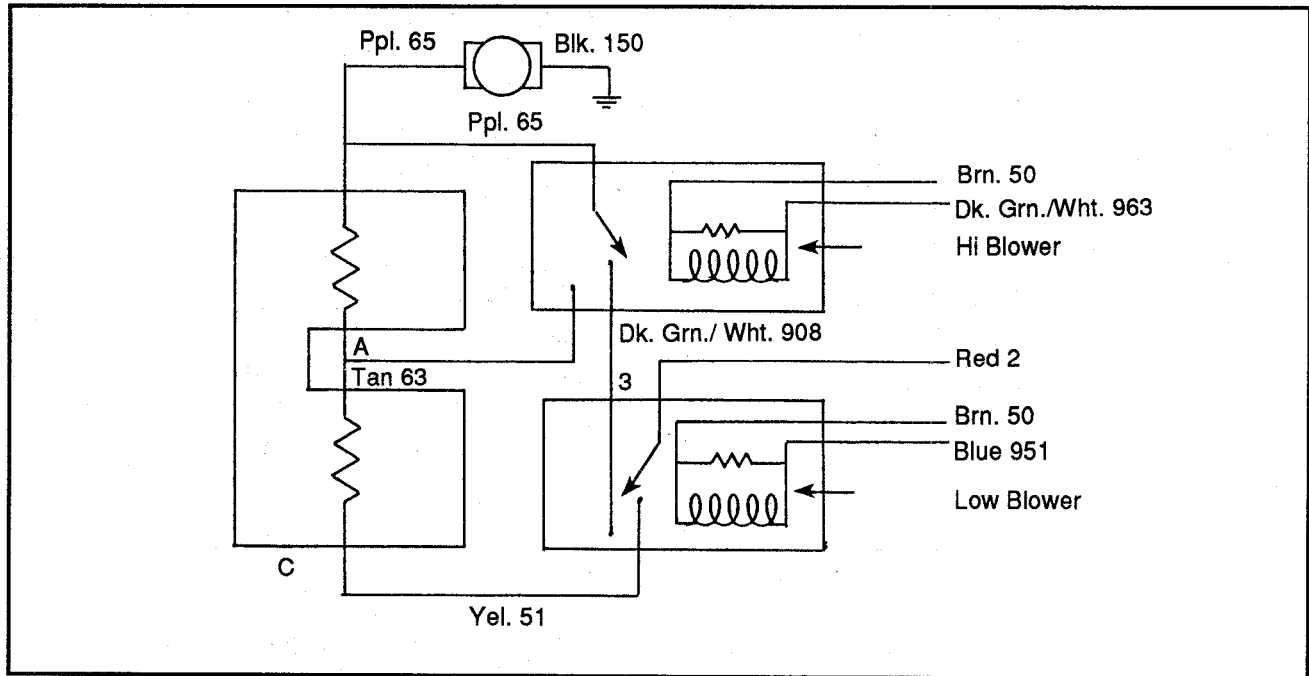
**8/VCS**Various Case  
Studies

8/VCS - GM

General Motors

8/VCS - GM - CKPT

CK Pickup Truck



**Figure 6:** Blower motor relay control wiring diagram

## Troubleshooting the Controller Circuits

To test the controller, begin by removing the controller from the instrument panel (IP) and the cover from the back of the controller connector. This will allow the insertion of test probes from the back of the connector. The DMM will be used to test the circuits. Do not use an analog meter.

Make sure the ignition switch is off and insert the positive (red) test lead to terminal 12 (circuit wire 2—red) and the negative (black) lead to terminal 8 (circuit wire 150—black). There should be a reading of 12 V. If there is no voltage present, check the A/C fuse link. Change the positive test lead to terminal A (circuit wire 50—brown) and turn the ignition switch to the run position. The meter should read 12 V. If there is no voltage check the AC/HTR fuse in the fuse block.

### Mode Door Control Motor Check

Move the positive test lead to terminal H (circuit wire 903—white) and the negative test lead to terminal 4 (circuit wire 904—dark green). Set the control to the “Defrost” position. The meter should read between -7 and -7.5 V.

Next turn the control to the “Heater” position and see if the reading is between

**8/VCS**

Various Case Studies

8/VCS - GM

General Motors

8/VCS - GM - CKPT

CK Pickup Truck

+7 and +7.5 V, then drops off to 0 after 5 or so seconds. Turn the control to the "Upper Air" position and see if the meter read +7 to +7.5 V.

**Mode Door Motor Feedback Potentiometer Check**

Move the positive probe to terminal D (circuit wire 362—red) and the negative probe to terminal 11 (circuit wire 361—purple). The reading should be between 3.0 and 3.5 V.

Set the control to the "Heater" position. The meter should now read between 1.0 and 1.5 V. Move the control to the "Upper Air" position. The reading should change to between .25 and .30 V.

**Temperature Control Motor Check**

Move the positive probe to terminal 3 (circuit wire 900—light green) and the negative probe to terminal J (circuit wire 901—light blue). Select the "Hot" position on the control panel. The meter should read between +7 to +7.5 V. Next, move the control to the "Cold" position and the meter should read between -7 and -7.5 V. The meter should fluctuate as the motor steps.

**Control Door Feedback Potentiometer Check**

Move the positive probe to terminal 10 (circuit wire 902—dark blue) and the negative probe to terminal 8 (circuit wire 361—black). Make sure the temperature is set to the "Hot" position. There should be a meter reading of .5 to 1.0 V. Move the selector to the "Cold" position. The reading should change to between 2 and 2.5 V.

**Air Inlet Control Motor Test**

Move the positive probe to terminal 7 (circuit wire 905—light green with black) and the negative probe to terminal 6 (circuit wire 906—pink with white). The reading should be between -7 and -7.5 V with the ignition on. With the ignition off, the reading will change to between +7 and +7.5 V. The difference in a positive and negative voltage will indicate the direction the motor is turning.

**Air Inlet Control Motor Feedback Potentiometer Check**

The positive test probe should be moved to terminal 9 (circuit wire 907—black with white) and the negative test probe to terminal 11 (circuit wire 361—purple). The reading should be low with the ignition off. With the ignition turned on, the reading will move to between 3 and 3.5 V.

**Blower Motor Check**

Move the positive probe to terminal A (circuit wire 50—brown) and the negative probe to terminal L (circuit wire 963—dark green with white). Set the blower speed to the "Lo" position. The meter should show a reading between 11.5 and 12 V.

Next, set the blower to the "Med" position. The reading should be 0 V. Set the blower to the "Hi" position and the reading should be between 11.5 and 12 V.

# 8/VCS

Various Case Studies

8/VCS - GM	General Motors
8/VCS - GM - CKPT	CK Pickup Truck

Move the negative probe to terminal M (circuit 951—blue) and set the blower motor to the “Lo” position. The meter reading should be between 11.5 and 12 V. Select the “Med” position. The meter should now read 11.5 to 12 V.

If the “Lo” blower relay does not activate, the blower will operate at the high speed in the “Hi” and “Lo” positions and there will be no operation in the “Med” position.

If the “Hi” blower relay does not activate, the blower will operate at the medium speed in the “Lo” and “Med” positions and no high speed in the “Hi” position. If both relays fail, there will be no blower motor operation.

## AC Clutch Relay Check

Connect the negative probe to terminal K (circuit wire 966—dark blue with white) and the positive wire to terminal A (circuit wire 50—brown). The meter should have a reading between 11 and 12 V.

## Conclusion

This concludes the checks for the A/C section. If any of the sections do not meet the required checks, there is a bad connection, bad CPU or bad component. Most likely there will be either a bad component or bad part. The CPU and control section would be the last to fail in this type of system.

It can be assumed that if the display is operating normally, the CPU is probably working fine. If the display is not working, and all the supply voltages for the control section are at the proper levels, the CPU can be assumed to be bad.

**8/VCS**

Various Case  
Studies

---

8/VCS - GM

General Motors

---

8/VCS - GM - CKPT

CK Pickup Truck

---

# Section 9

# Computer Equipment

---

## Table of Contents

<b>9/PC</b>	<i>Personal Computer</i>
<b>9/PC - AM</b>	<i>Architecture of Microcomputers</i>
<b>9/PC - C</b>	<i>Components of the PC</i>
<b>9/PC - TE</b>	<i>Test Equipment</i>
<b>9/PC - TR</b>	<i>Troubleshooting and Repair</i>
<b>9/PC - TR - FDD</b>	<i>Floppy Disk Drive</i>
<b>9/PC - TR - HD</b>	<i>Hard Disk</i>
<b>9/PC - TR - K</b>	<i>Keyboard</i>
<b>9/PC - TR - PS</b>	<i>Power Supply</i>
<b>9/PC - VCS</b>	<i>Various Case Studies</i>
<b>9/PC - VCS - 286</b>	<i>286 Computer System</i>
<b>9/PR</b>	<i>Printer</i>
<b>9/PR - A</b>	<i>An Introduction</i>
<b>9/PR - M</b>	<i>Maintenance</i>
<b>9/PR - TR</b>	<i>Troubleshooting and Repair</i>
<b>9/PR - TR - LP</b>	<i>Laser Printers</i>

Section 9 • Computer Equipment

Table of  
Contents

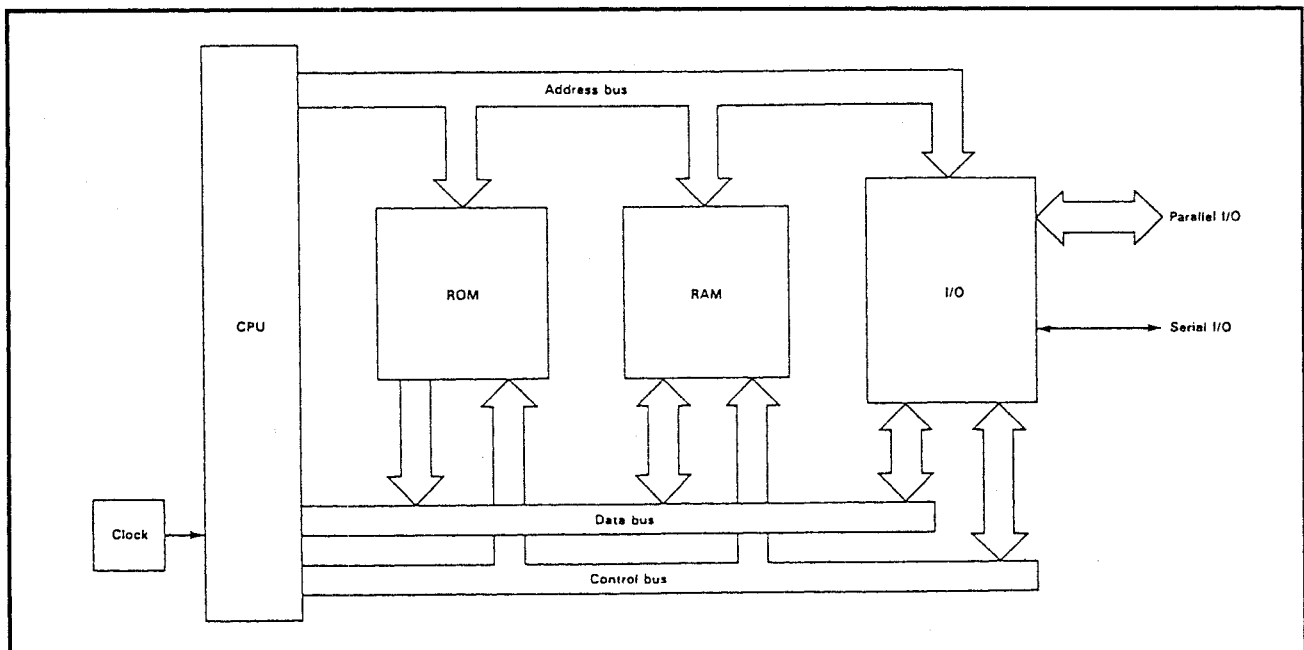



## 9/PC Personal Computer

### 9/PC - AM Architecture of Microcomputers

#### Block Diagram

Microcomputer systems have a certain number of similarities in their construction. Figure 1 shows a simplified computer architecture.



**Figure 1:** Block diagram of simplified computer architecture

#### CPU

The main control of any computer is the central processing unit (CPU). The CPU is the heart of the microcomputer system. It must accept instructions from a program, decode the information and execute it. CPUs of today are very complex with more than 68,000 devices within.

#### ROM

For the CPU to function, it must have a way to interpret and way of knowing what to do with the instructions being sent to it. The read-only memory (ROM) provides permanent (non-volatile) storage for control programs, operating systems and high-level language interpreters.

- EPROMs** EPROMs (erasable-programmable read-only memory) can be used in place of ROM. These allow the ability to electrically re-program the IC when changes or additions have to be made to the various control programs and operating systems. In fact, many of the control chips used in PCs are EPROMs and not simply ROMs.
- RAM** The random access memory (RAM) provides the read/write memory and is considered to be volatile memory since it will lose any contents if the power supply to the IC is interrupted. Some computers have battery-backed RAM. These RAMs are usually CMOS (low-current) memory and are used primarily for the long-term storage of system configuration. Most RAM used for program execution and data storage while running software will be dynamic type RAM which require refreshing in order to retain stored data.
- I/O Devices** To communicate with the real world, the computer system requires some means of connection for peripheral devices such as keyboards, displays and printers. In addition, a means of connecting mass storage devices such as floppy or hard disk drives will be required. This is done by means of a number of input/output (I/O) devices. Some I/O devices transfer data a byte at a time and are known as parallel I/O devices, and others transfer data a bit at a time and are known as serial I/O devices.
- Bus Systems** Connecting the various elements in a microcomputer requires a number of bus systems. There are the data bus, the address bus and the control bus that can be found in a microcomputer.
- Data Bus** The data bus provides eight, sixteen or thirty-two parallel connected lines which link the microprocessor, RAM, ROM, and I/O devices. Data and microprocessor instructions appear on these lines as groups of eight, sixteen or thirty-two bits. The data appears in binary form as a pattern of lows (logic 0s) and highs (logic 1s).
- Address Bus** The address bus can comprise 16 (or more) parallel connected lines upon which address information is placed. Unique addresses are used to identify memory locations and I/O devices. An address decoder is used to select a device whenever an address appears within a particular range (i.e. an address in the RAM, ROM or I/O space).
- Control Bus** There may be as few as five or more than ten control bus signals depending upon the complexity of the microcomputer system in question. Typical examples of control bus signals are reset (when activated, this signal causes the system to be re-initialized) and a non-maskable interrupt (a signal which will demand the attention of the microprocessor regardless of whatever else it is doing at the time).

## 9/PC Personal Computer

---

### 9/PC - C Components of the PC

---

The basic PC being discussed for troubleshooting and repair in this section is the IBM PC. The original IBM was either an IBM PC or an IBM PC/XT. The newer IBMs are known as PS/2 systems. A typical IBM PC clone can be either an XT, AT, 386 or 486 machine. (Repairs and troubleshooting for the original IBM PC will be, typically, the same as for the XT and the clones of both.)

#### Reset Switch

The reset switch is a means for starting the computer again if something were to go drastically wrong, or is used instead of the typical CTRL-ALT-DEL three-key reset. The reset switch works almost the same as turning the computer off.

Original IBMs and clones did not have reset switches, which meant the unit had to be turned off and then back on. If a hard drive were being used, you would have to allow time for the drive to stop, and then time for the hard drive to come up to speed after turning the system back on. This function could also be done by pressing CTRL, ALT and DEL keys together (a soft boot) but this would not always reset everything properly.

#### Power Switch

The power switch for the PC is located on the right rear of the XT and AT cases. This switch is a big red switch clearly labeled "ON" and "OFF". Many people have probably never seen this switch as you just feel for it.

Some of the new machines will have the power switch located on the front. Usually these power switches will be on a "tower" case, such as with a PS/1 or a PS/2. In all cases, the power switch turns off the AC current to the power supply section.

#### Speed Switch

The PC can operate at speeds from 4 MHz (PC) to 50 MHz (486). XTs up to 486s are speed selectable, either through software or hardware. This switch is often referred to as the "turbo" switch for XT and some AT machines. This switch will change the top speed (i.e. an AT at 12 MHz) to half speed (non turbo mode). Some of the higher AT, 386 and 486 machines will have variable speed section capability and an LED display which will indicate the speed.

### Key Lock

With some XT's and all AT's and faster machines will be a key lock. This key lock will turn the operation of the keyboard off so unwanted users cannot access your computer. This key lock does not protect the computer from being turned off, but merely from interrupting, or using the computer.

### Disk Drive Bays

In a PC can be several different combinations of computer disk drives. The original PC would only allow room for two physical disk drives. Starting with XT's one is able to put up to 4 physical drives in the casing. This was due partially to a redesigned architecture but mostly to the coming of half-height drives which would fill only half of the original space.

The standard drives for a PC system are two 5.25" drives (both 360K), or one 5.25" drive (360K) and a hard drive. An XT can have up to two 5.25" drives with up to two hard drives.

AT, 386, and 486 machines are able to accept 5.25" (high density) drives, 3.5" drives (high density), hard drives or any combination. 3.5" drives can be used on XT's with the proper controller card as well as high density 5.25" drives.

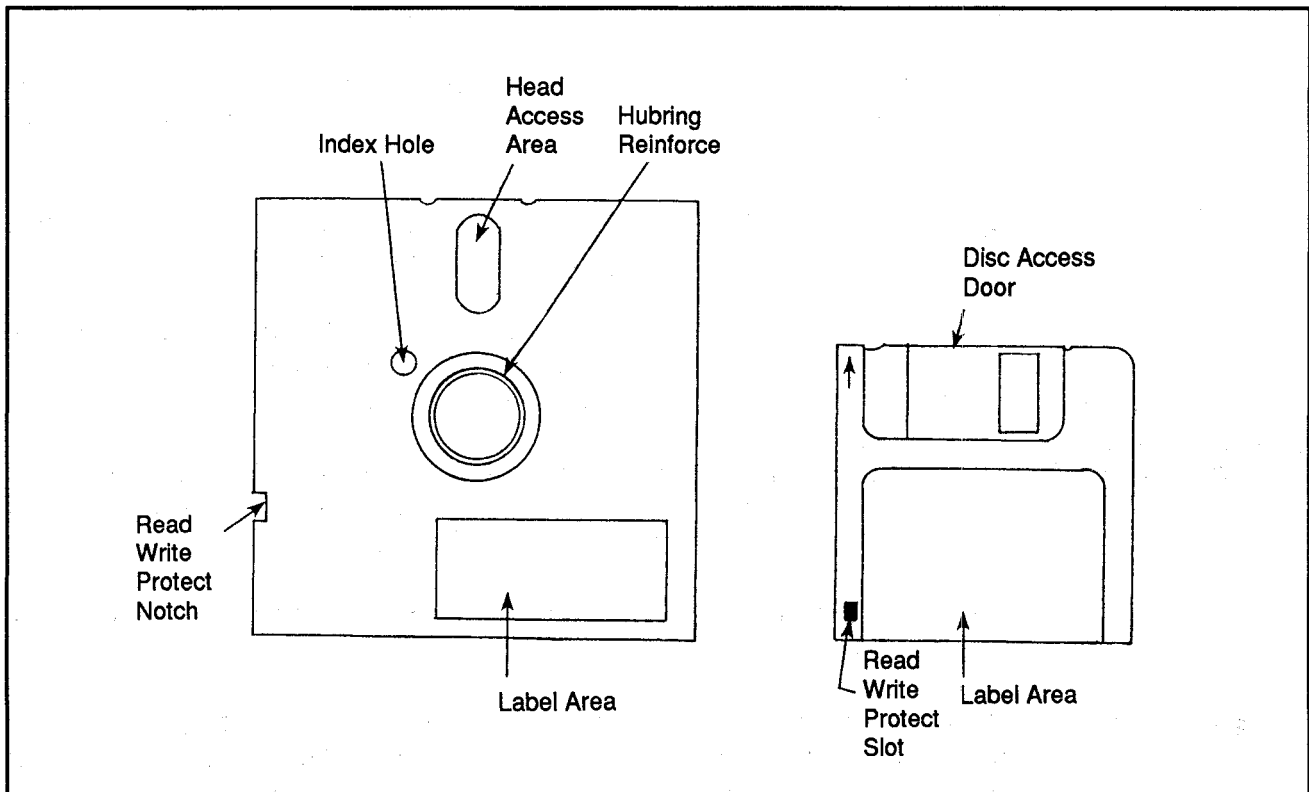


Figure 1: Floppy diskettes

Other type drives that may be added to any PC include tape drives, Bernoulli drives (removable hard drives), CD ROM drives and a host of other peripheral drives being constructed. Most any combination of drives is possible with all models of PCs in today's market.

### Power Connectors and Supply

When looking at the back of a typical AT (basically the same on and XT or PC) on the left side is the power section. There will be two three prong sockets. The female socket is for the power cord, and the male socket is for a monochrome monitor. (Some newer power supplies may not have the monitor power socket.) The monitor socket is turned on and off with the power switch for the computer.

Also there will be a fan vent. In a typical PC/XT/AT there will be a fan mounted inside the power supply that draws air through the computer and blows it across the power supply and out the vent. Newer computers may have a second fan that is located in the front grill to pull air in.

The power supply of a typical PC converts the house current to voltages that the computer can use. These are typically +12 V, -12 V, +5 V, and -5 V. The power supply is rated in wattage which determines how many devices you can put in your computer.

The original IBM PCs had power supplies of about 67 W which were sufficient for two floppy drives (some users were able to run 1 floppy and 1 hard drive off these power supplies).

An XT would typically have a power supply of about 120 to 150 W. This is more than enough power for two floppy drives and two hard drives.

Most power supplies available today will be 150 W or greater. 386 and 486 machines will have minimum power supply of 200 W, allowing the control of several floppy drives, tape drives, CD ROMs, etc.

### Keyboard Connector

Moving to the right, in the middle and at the bottom will be a 5-pin din connector. This connector is for hooking the keyboard to the computer. This connector is discussed further in the section on troubleshooting keyboards.

Above the keyboard connector will be connectors for a printer port and a serial port or joystick port.

### Expansion Slots

On the left side are the expansion slots. These slots are the computer's way to connect internal circuit boards to the outside world. Here you will find various connectors and switches, depending upon which expansion cards have been added.

## Motherboard

The heart of a PC is the motherboard. It holds all the components necessary to make your computer function. Motherboards vary slightly in the placement of components, but the basic layout will be the same for all motherboards. The expansion slots are located at the rear of the board with anywhere from 5 to 8 expansion slots available. At the rear and to the right will be the power connections to connect to the power supply. Accessing the motherboard means that almost always a certain number of items will have to be removed.

## CPU

The central processing unit (CPU) is the IC that processes all the other information a PC will gather. There are a variety of CPUs in use and they are discussed below.

### 8088 CPU

The 8088 CPU is the chip used in the IBM PC and XT computers and clones. The chip is manufactured by several different companies such as Intel (the creator), Advanced Micro Devices, and Harris Semiconductors.

As powerful as it was in its time, by modern standards the 8088 is the bottom-of-the-line processor with an 8-bit data bus and can only move a single byte of data at a time. It has a 20-bit address bus which allows a maximum of a one megabyte address range. PCs can only use 640K of this 1M for user processing. The remaining memory is for various other functions. This limitation is what has plagued the PC for many years with being unable to expand beyond this range. Expanded memory techniques were added to advance beyond this limitation and will be discussed in expansion board troubleshooting.

### 8086 CPU

The 8086 is virtually the same as the 8088. The only difference in the 8086 is the 16-bit wide data bus instead of the 8-bit data bus of the 8088. The advantage of this chip is the ability to move twice as much data which means the computer can process information twice as fast (or as fast as software will allow). The 8086 was never used in the IBM line but can be found in clones.

### 80286 CPU

The 80286 CPU is more commonly known as the PC AT computer. The 286 machine can run three to five times faster than an 8088 machine. 286 machines are considered to be the entry level computer by today's standards (although some discount houses still produce XT machines with 8088 or 8086 processors.)

The 80286 uses a true 16-bit data bus and can move 2 bytes of data at once. The address bus in a 286 is 24 bits as opposed to the older 20 bit bus. The 286 can then handle up to 16 MB of address space. 286s run at faster clock rates than 8086 machines. 8086s were limited to about 8 MHz (some at 10 MHz) and 286s can run as fast as 16 MHz.

**80386 CPU**

The next generation CPU was the 80386, which was top of the line until 1990. At about this time the prefix “80” was dropped from the name of the chip and they are referred to as 386s (also the chip is now labeled i386 for which Intel is the sole creator). The 386 has a 32-bit data bus which can move 4 bytes of data at one time. It is capable of accessing over 4 billion bytes of data and runs at much faster clock rates. Some top of the line 386s can run at 50 MHz, but are typically sold as 33 MHz machines. The 386 offers so many powerful features over the previous CPUs that standard software created for the older machines can’t take advantage of these features. Newer software is just now beginning to take advantages of these newer features.

There are several different versions of the 386 IC. The first is the 386 DX which is the first version and the fastest. The DX means the chip has a 32-bit data bus.

The second is the 386SX. This version cannot move data as fast because it only has a 16-bit data bus. Upgrading from a 286 to a 386SX does not offer much improvement to performance. The two chips are basically the same as far as software is concerned.

The third version of the 386 family is the 386SL. This IC is a special 386 with many of the other PC-compatible components added. The advantages gained by using this chip are that it allows for smaller designed computer systems like laptop computers.

Some of the original 386DX chips used in PCs had a flaw in their construction. This flaw would occasionally show up in certain floating-point arithmetic operations. It would be possible to get the wrong answer to some obscure math problems. The chip was fixed rather quickly and stamped with the two Greek sigmas ( $\Sigma\Sigma$ ). If the 386 chip is stamped “for 16 bit software only” it is one of the original chips with the problem. (The chips with flaws were distributed to third party computer companies with this stamp.)

**80486 CPU**

The 486 (i486) chip was introduced in 1989 and has many improvements over the 80386 chip. The major improvements are a floating-point unit (FPU) and a cache.

A floating-point coprocessor is a special circuit used to speed up math calculations. It is like having the coprocessor chip built into the same chip (normally the coprocessor must be added later in another IC).

A cache is a special kind of memory that accesses data faster, either from standard memory or from disk storage. This improves the overall speed of the 486 over the 386.

### Coprocessor ICs

A second processor can be added to most PCs and is known as the coprocessor. The second IC is not a CPU but rather an extension of the CPU to handle math functions. Math coprocessors have the same number as the CPU with the last digit changed to a "7" (i.e. an 80286 would have an 80287 coprocessor). The second processor is the numeric processor extension (NPX), the floating-point processor (FPU) or simply the math chip.

The main CPU must spend a lot of time doing math functions. By adding a math chip, the CPU can send these functions to it, and be freed to process other information. It then can retrieve this data after being processed by the math chip. The math chip can process mathematical functions 10 to 300 times faster than the CPU alone. Software must be able to use the math chip, or there will be no improvement in speed.

Math chips are available for all the CPUs mentioned except for the 80486 chip. This chip does not need an external math chip because the functions are built into the IC.

### Memory

Another section of the motherboard holds the memory chips needed to process information. Without memory, your computer would have no place to park the instructions that will be needed for processing.

Memory capacity is measured in units called bytes. Bytes measure how much information chips can store. Generally speaking, one byte is equal to about one character of the alphabet, or number. A byte is divided into 8 bits. Each bit is the "1" or "0" required to make a computer work. It takes 8 bits to make a character (1 byte).

Memory capacities should be listed in bytes and not bits. Manufactures who list products that are capable of megabits of information are only able to handle kilobytes of information. A million bits sounds like a lot but is actually only 125 kilobytes.

For technical purposes, a kilobyte is equal to 1024 bytes. A megabyte is actually 1,048,576 bytes. Rounding, slightly, is always used when referring to the capacity of a computer's memory or storage capabilities.

### Memory Chip Packages and Speed

Early PCs used 16 KB chips arranged in banks of 9 chips in each bank. This meant you could have a maximum of 64 KB (4x16). Later machines could hold one to four banks of 64 KB (set of 9 chips per bank) for a maximum of 512 KB, or two banks of 256 KB chips and two banks of 64 KB for a maximum of 640 KB.



640 KB is the maximum memory a PC can use under DOS, its operating system. ATs and compatibles can usually take four banks of 256 KB each bank for a total of 1 MB of memory. (Remember, DOS allows only 640 KB to be used. The rest is for cache, extended, or expanded memory, explained later). Some newer boards allow for 1 MB banks for a maximum of 4 MB of memory.

The early memory chips ran at speeds of 200 or 150 nanoseconds. This has improved. On a memory IC there will be the memory number followed by a dash and the speed of the chip (i.e. a 41256-80 is a 256 chip that can run at 80 ns). The smaller the number, the faster the chip can be accessed by the computer. ATs (and higher) usually will need speeds greater than 100 ns to operate properly.

Early memory ICs were constructed as Dual In-line Packages (DIPs). These chips have a polarity notch at one end and a dot indicating pin 1 of the chip. This indicates the correct way to position the chip.

Newer motherboards began using memory packages. These memory chips are surface mounted on small circuit boards. They come in two styles called SIMMs (Single In-line Memory Modules) or SIPs (Single In-line Packages). SIMMs or SIPs can house memory chips that can hold from 256 KB chips to as much as 4 MB chips. This allows motherboards to have much greater memory capacities without the need for a larger IC footprint.

## Monitors

Without a monitor, there is little one can do with a computer. Short of starting the computer and allowing it to process a self running program, you need a monitor to see what is being processed by a computer.

With some of the original color graphics cards available, it was possible to hook the computer to your television through the use of an RF converter. The frequency of a CGA card was set at 15.750 kHz (compatible with standard television) for the horizontal rate and 60 Hz for the vertical rate.

The resolution achieved on normal televisions would not allow more than 40 columns of text to be viewed. The IBM's normal 80 column mode is too small for most televisions to display without the image being too fuzzy to read. The need for a higher resolution monitor requires that a computer monitor to be used.

Today the low end monitor for a PC is considered to be a monochrome VGA (Virtual Graphics Array) monitor. It is still possible (though discount houses) to purchase CGA (color graphics adapter) monitors and monochrome monitors, but they are slowly being phased out.

The original monochrome monitors were able to provide resolutions up to 600 x 200 pixels. CGA cards could provide 600 x 200 pixels of resolution (with 16 colors) for text and 320 by 200 for graphics (4 colors). Today's top of the line VGA monitors are capable of producing 2096 x 2096 resolutions with over 32,000 colors.

These monitors are not compatible with current television receivers because they operate at different frequencies for different resolutions. The VGA adapters may operate at fixed frequencies (31.5 kHz horizontal and 60 kHz vertical) or multi-frequencies. Monitors are able to operate (for many VGA applications) at different frequencies and are often referred to as multi-scan monitors.

Monochrome VGAs and standard VGA monitors operate at fixed frequencies. They are not able to adjust for operation in resolutions above 640 x 480 (on the average).

Graphic cards are categorized by a veritable alphabet soup. There are CGA, EGA, MDA, PGA, VGA, SVGA cards (and a few more). Figure 3 gives a listing of some monitors available.

**Table 1**  
**Graphic Cards**

Name	Meaning	Computer	Horiz. Scan Rates kHz	Vert. Scan Rates Hz	Analog Or Digital
MDA	Monochrome display adapter	PC/XT/AT	18.02	50	D
CGA	Color graphics adapter	PC/XT/AT	15.75	60	D
HGA	Hercules graphics adapter	PC/XT/AT	18.02	50	D
EGA	Enhanced graphics adapter	PC/XT/AT	21.85	60	D
			18.02	50	D
			15.75	60	D
PGA	Professional graphics adapter	XT/AT	31.50	60	A
VGA	Video graphics array	ALL PCs	31.50	60	A/D
			31.50	70	A/D
			35.50	43.5	A
MCGA	Multicolor graphics adapter	ALL PCs	31.5	60	A
			31.5	70	A
SVGA	Super VGA	ALL PCs	all above		A/D
			31.5 to 48	60 to 87	A/D
XGA	Extended graphics array	PS/2	31.5	43	A
		PS/2	35.5	87	A

**Floppy Drives**

The floppy drive (as well as the hard drive or tape drive) is a semi-permanent storage device. They are called semi-permanent because RAM memory is temporary and because even these devices have their problems. Nothing is permanent.

Floppy drives are less expensive but store data more slowly and store less data than do hard drives. They do have the advantage of not running out of space. If one disk is filled, you simply place another disk in the drive until it is filled and then insert yet another. Hard drives have a physical limitation for space. Once filled you must either remove files or buy another hard drive.

There are two types of floppy drives in use: the 5.25" drive and the 3.5" drive. 5.25" drives for PCs have limitations of 360 KB for low density drives (standard PC/XT drives) and 1.2 MB high density drives (AT/386/486 drives). The 3.5" drives can store 720 KB for low density drives and 1.44 MB for high density drives. These higher density drives are usually found on ATs and above, but can easily be used on PCs and XTs with the right hardware and software.

**Hard Drives**

A modern computer cannot function without some type of hard drive. Hard drives are also called fixed disk drives.

The minimum hard drive space of today is about 30 MB of storage space. Buying drives of less capacity than this is often difficult if not impossible. Older, lower capacity drives can be found at electronic junk stores. Original PCs had 5 MB and 10 MB drives, when they became available. Since then hard drives have grown to store Gigabytes of information.

**Disk Controllers**

In order for a disk drive or hard drive to function, it must be connected to a controller. The disk controller is an adapter card that plugs into one of the expansion slots of the computer.

Floppy controllers are available to handle low/high density drives or any combination. They can drive from one to 4 disk drives.

Hard disk controllers are capable of controlling one or two hard drives of the same type. These controllers are not able to be used for floppy control.

Hard and floppy controllers can control up to two hard drives and two floppy drives. By using such a card, it cuts down the need for two expansion slots to one. Most people do not have more than two floppy drives in their computer, so the loss of a floppy drive controller that can control 4 drives will usually go unnoticed.

**Table 2**  
**Disk Controller**

ST 506/412	The first early hard drive was the Model 506 from Seagate Technology. This drive had a 5 MB capacity, was heavy, and mounted in a full-height case (it took up the space of two modern drives). It wasn't very fast, but did offer a large media (at the time) for storage and retrieval of most often used software. It used a two ribbon cable method to hook to the controller card which until recently was the standard method for hooking hard disks to PCs. This standard was known as the ST506/412 interface.
MFM	The Modified Frequency Modulation (MFM) method of recording data to hard disk was the first. Each bit of data is represented by one magnetic spot (flux change) on the disk.
RLL	A variation on the standard ST506 drive that allows the packing of between 50 and 100 % more data on the exact same hard disk is the Run Length Limited (RLL) method. In this method the precise rotational speed of the drive and precision electronics are used to allow a sequence of 2 to 7 bits to be recorded by a single flux change. This is called the 2,7 RLL method. Variations of this method have been used to record more data on a hard disk drive.
ESDI	The Enhanced System Device Interface (ESDI) was born to help eliminate problems associated with the limited number of drive descriptions allowed in a BIOS table. Most ESDI drives can transfer data at twice the rate of RLL or MFM drives. ESDI also allows for higher capacity drives at a higher transfer rate.
IDE	<p>The Intelligent Drive Electronics, Integrated Drive Electronics, or Integrated Device Electronics (IDE). No one seems to be sure what the definition of IDE is. IDE drives only need a single ribbon cable connection to work. ( ST506 type controllers need two cables to function).</p> <p>IDE is relatively new, with its existence a part of the latest developments in electronic miniaturization. A hard drive with IDE has the controller built into the drive electronics and does not need a separate controller card. The drive can be attached directly to the motherboard. This allows motherboards with IDE connections to free up the use of an expansion slot. IDE manufacturers do make a card that will use an expansion slot if an IDE connector is not available.</p>
SCST	The Small Computer System Interface (SCSI) has been primarily used by the Apple Mac computer system. Only recently has the PC begun to use this type of controller. The major advantage of a SCSI controller is that it is not designed for a single type of peripheral. It can be hooked to up to seven different peripherals at the same time. The SCSI controller board is often referred to as a host adapter. With this controller, you could have a CD-ROM drive, a printer, a tape backup system, a scanner, hard disks and other peripherals hooked through the same expansion slot.

**Power Supplies**

The power supply is the heart of the computer. Without it, nothing can function. Power supplies can operate on 120 V at 60 Hz in the U.S. and may be switchable (or have line sensing) to be used in countries with 50 Hz and 240 V power. A power supply in an original PC will not be powerful enough to run a variety of devices and may need to be changed. Power supplies will usually have two connectors which power the motherboard, and four connectors used to power various peripherals like hard drives and floppy drives.



---

9/PC - TE

---

Test Equipment

---

---

## 9/PC Personal Computer

---

### 9/PC - TE Test Equipment

---

There are only a few items that would be needed to fully test a PC. As with most hi-tech repairs of today, you will normally swap and replace complete sections rather than trying to locate the individual part at fault. Simple fixes like resistors, capacitors, diodes or cracked PC board etching could be easily found and replaced on the board. More severe problems usually require replacing the board.

#### Breakout Box

A breakout box is used to find problems in an RS-232C “serial” interface. It is designed to be connected in line with the serial cable. As the signal passes through the breakout box, LED indicators show the state of each of the signal lines. By watching the indicators you are able to determine if the interface is working correctly.

Breakout boxes can be as inexpensive as \$25 and powered by the serial line, or costing more than \$100 with a separate power supply and a jumper block. (Jumper blocks allow you to reroute some of the serial signals.)

#### PC Computer

Aside from using test equipment mentioned in Section 4 “Tools and Test Equipment”, the use of a compatible PC on your workbench is a must. Having a unit in which you can insert expansion cards, peripherals and exchange power supplies is the best way to determine where problems are.

In a way, this is parts swapping in reverse. Instead of inserting a new board to test a suspected board, you are placing the suspect board into a system which you know to be operational in all other respects. If the suspect board doesn't work, you know that it is malfunctioning.

Compatibility is essential. You cannot plug a board from a Macintosh into an IBM-PC and expect it to work. The computer you have must also be capable of supporting the functions. Trying to test a hard drive in an old PC with a 67 W power supply probably isn't going to work.

This means that you'll either have to own more than one computer, or will have to limit this aspect of your testing to whichever you have.

### Automatic Test Equipment

Various automatic diagnostic instruments are being manufactured now that can locate problems in just minutes. Such devices are used in place of the damaged computer's CPU. A cable from the test unit is plugged into the CPU slot and every circuit and component on the mother board is checked. This can save hours and expense in troubleshooting.

The problem is a common one. These testing units are costly, generally far more than the budget of even a well-established repair shop.

### Logic Clip

A logic clip is similar in appearance to an IC test clip. The logic clip fits over the pins of an IC being tested. A series of LEDs on the top of the logic clip indicate the logic state of each pin. By feeding known signals to the IC, watching the output on the logic clip, and comparing the results with a truth table, you are able to tell if an IC is working correctly.

Logic clips are specifically designed to work with certain chip sizes (8 pin, 16 pin, 24 pin, etc.). They are relatively inexpensive (under \$200). The logic clip is small and convenient to use.

Its LED's may be designed to glow one of two colors when the signal is either "high" or "low". The clip will be powered by the IC being tested and automatically identifies the voltage and the ground pins.

The logic clip can only be used with ICs that are capable of changing states at a slow rate rather than fast state changes. This makes it difficult to use in computers, but you may find it possible to locate software written for that particular computer that can cause certain tasks to loop in a way that that logic clip can read.

### Logic Comparator

The logic comparator will compare a suspect IC with an IC that is known to be good. An IC clip is attached to the IC being tested. The known good IC is placed inside the logic comparator. The comparator will tell the operator if the two chips seem to be working the same or not. This is a simple Go/No-Go test.

The logic comparator is a fast way to check ICs in a circuit board. With a beginning price of about \$1000, they are fairly expensive, a cost made worse because you also need an IC known to be good for the device to work.

**9/PC**Personal  
Computer

9/PC - TE

Test Equipment

**IC Tester**

The IC tester is a stand-alone unit designed to test ICs out of circuit. The IC tester will have an on-board computer that will diagnose the internal workings of an IC. It can have a library of test routines that can be recalled for various ICs.

The advantage of an IC tester is that you don't have to know too much about a circuit being tested. If the IC is in the tester's library, the operator can run the test routine by calling it up to check for a Go/No Go test.

With this type of unit, you are able to test each removable IC of a board, one by one. These units can start as low as \$200.

**CPU Simulator**

A CPU simulator (or No-Op tester) replaces the operation of the CPU while testing. The CPU is removed and the simulator test connector is plugged in.

The CPU simulator can be set to send particular instructions down data lines and control lines. This will allow for checking to see if switching is being controlled properly by the CPU. This device is good for system boards that are completely dead (processing wise).

These testers cannot be used for testing dynamic RAM. RAM must be constantly "refreshed" and these signals come from the CPU. With the CPU removed, no "refresh" is sent.

On a computer with a 16-bit address bus, 8-bit bus, and 12 control lines, the simulator may have 34 or more switches. Each time a different step is selected, a switch may have to be changed. This could be very time consuming and you could easily lose your place.

**Signature Analyzer** The use of a signature analyzer assumes that proper documentation for the specific machine or circuit you are working on is available. Also signatures (predetermined codes) for the circuits must be included in the documentation for the specific machine or circuit.

A signature analyzer is a Go/No Go tester. A specific code will be generated at a test point under certain conditions. If during these conditions the codes match a look-up table, the circuit is OK. If not, there may be a component that is bad.

It is possible for a tech to make his/her own signature readings by taking readings from an identical system and comparing the two.

These devices start at about \$1000.

**Disk Drive  
 Exerciser**

A disk drive exerciser may be computer based or stand-alone. A computer based exerciser would be software that continuously tells the drive to spin or to perform some other task. A stand-alone device would allow the testing of a drive outside the computer. The stand-alone devices can be quite costly. The software is often a part of an overall diagnostics package.

**Diagnostic  
 Software**

One of the innovations that IBM put into their first consumer computers was the built-in power-on self test (POST). This runs a mini-check on the entire system each time it is turned on. The components checked are the CPU (central processing unit), ROM (read-only-memory), motherboard support circuitry, RAM (random-access-memory) and the major peripherals. The tests are brief and not very extensive, but they give the operator at least some idea when things are not working correctly.

Some of the POST error codes are audio, in the form of beeps. For example, when the PC is first turned on and completes the preliminary diagnostics, it will emit one short beep to indicate that all is ok. A longer beep or series of beeps indicates that something is wrong.

**Audio Codes**

Audio Code	Possible Fault Area
No Beep	Power supply
Continuous Beep	Power supply
Repeating short beeps	Power supply
1 long and 1 short beep	Motherboard
1 long and 2 short beeps	Video adapter card
1 short beep and bad/no display	Video cable and/or display
1 short beep and no boot	Disk cable, adapter, or drive

On most computers if the preliminary POST test is passed, the system will display the system memory that has been checked. The last number displayed will be the amount of memory that was tested properly (i.e. 1024 KB means 1 meg of memory was checked ok).

If the computer manages to get the display up and running and then develops a problem, it will indicate an error code on the screen. The device with the error will be displayed. The first two numbers are the device and the last two the error. If the last two digits are "00" the device is ok. Section "12/1-PC-POST" shows some of these error codes.

Most AT (and higher) computers have self checking diagnostic routines that can be run before any operating system is loaded. When you turn on the computer, the screen will indicate the key to press to access the diagnostics and setup sections. These are self-explanatory and will help track down possible problems.



**Software**

Other software is available for testing computers for problems. Software such as Norton's Utilities, PC Tools, Check-It and a variety of others are designed to completely test a computer with problems, as well as to perform periodic maintenance for disk drives and hard drives, and even recover from certain errors.

Some software like Spin Rite is available to reformat hard disks without removing the data that is located on the disk. These programs will also improve performance of the disk drive.

Realignment disks are available for those floppy drives that may drift. These are generally available from floppy drive manufacturers and they are documented for proper use.

There are also many public domain, shareware and "try before you buy" software programs available from your local Bulletin Board System (BBS). This is an excellent way to get good software at a cheap price.

For the professional shop, some computer manufacturers offer complete diagnostics packages containing diagnostic software and a manual (or manuals) dealing with the specific technical information on that computer. Sometimes this will even include some schematics.

Section 9 • Computer Equipment

**9/PC**  
Personal  
Computer

9/PC - TE

Test Equipment

## 9/PC - TR

### Troubleshooting and Repair

## 9/PC - TR - FDD

### Floppy Disk Drive

#### Power Leads

If a floppy disk drive is suspected of being defective, make sure that the problem isn't with the disk being used. Then check to ensure the power going to the drive is correct. The power leads for the connector should read:

Minimum	Maximum	-Lead	+Lead
+4.8	+5.2	2	4
+11.5	+12.6	3	1

#### Cables/ Connectors

Check that all the cables and connectors are plugged in correctly (not all are keyed to ensure Pin 1 and the red band are on the same side).

Refer to the POST error codes from Section "12// - PC - POST." These codes will detect which drive is bad and will be 6.xx codes.

Check to see if the drive is configured correctly. ATs have software configuration CMOS setups that must match the drive or the drive will not work properly. Refer to running the setup protocol when starting the computer or rebooting. Make sure that the drive selected is the same kind being used. PCs and XTs will have jumpers that may be set wrong.

If the light on the drive stays on when the computer is turned on, it will usually mean the disk controller cable has been connected the wrong way. This does not do any damage to the disk drive. Turn off the machine and reverse the cable. The same may be true for hard drives.

Cables for floppy drives and hard drives are usually not interchangeable. The ribbon cable for floppy drives will have a twist of seven wires starting 9 wires from pin 1 (the different colored cable). This twist determines which drive is drive A and drive B.

3.5-inch drives can have one or two heads. Most will be found with two heads (information is written to both sides of the disk).

### Read/Write Head

Each read/write head is built around a core of soft iron. The coil is tapered in the center to act as two separate coils. When information is written to a disk, a charge is applied to the coil creating a magnetized spot on the oxide layer of the disk. When the drive reads from a disk, the process is reversed. The magnetic spots induce lines of force in the soft iron core (disk head) which is then amplified to produce a signal.

### Frequency Modulation

There are several different methods for storing information on a disk. One is the frequency modulation (FM) recording formation. Normal frequency of zeros occur at specific points or clock pulses. A double occurrence of these points is read as a zero.

Higher-density floppies use a method of encoding known as modified frequency modulation. Signals are read in a similar fashion as a laser reads the pits and lands on CDs, only magnetically. As transitions occur in the recorded signal, a “0” or “1” is read.

Some drives use a portion of the read/write head to erase the edges of each track as it is written. This prevents the overlap of signals from one track onto another.

### Write Protection

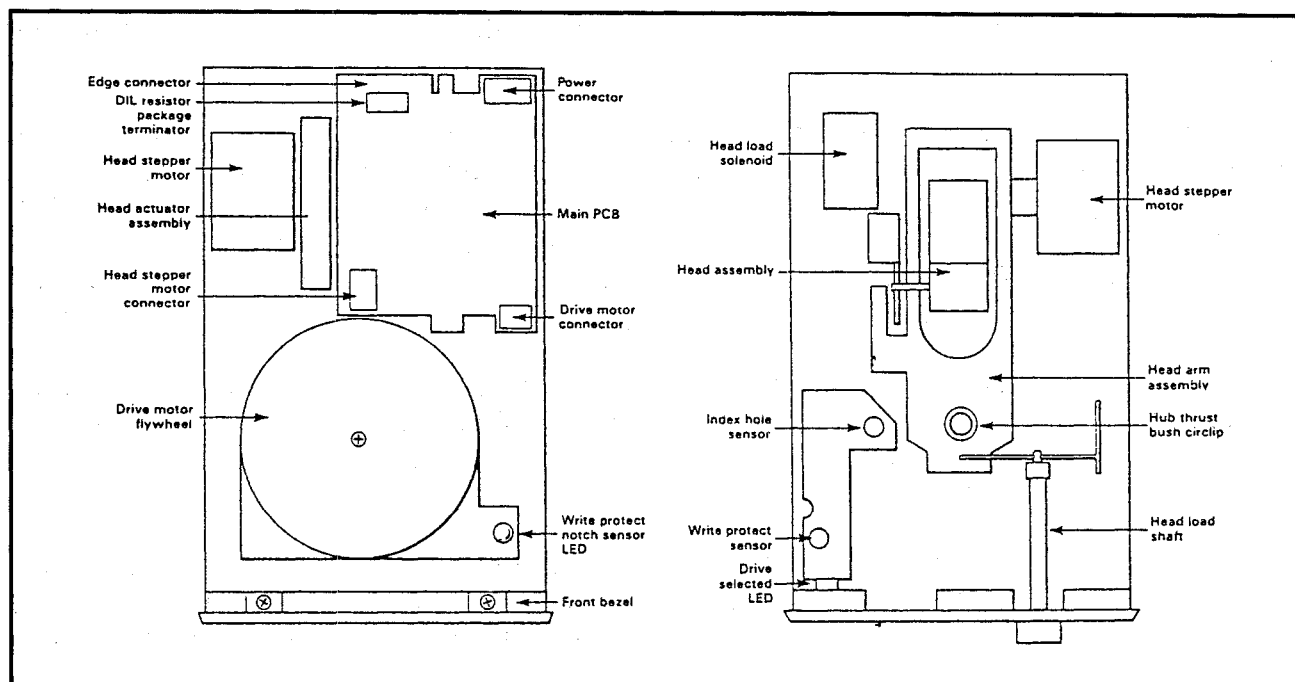
A “Write-Protect” scheme prevents a disk from being written to. On a 5.25-inch disk there is a physical notch which prevents the drive from activating the head in the write mode. When this notch is absent, the disk cannot write. A 3.5-inch disk has a little slide that is set either open (write protected) or closed (not write protected).

### Floppy Disk Types

The construction of a 5.25" floppy disk is shown in Figure 1. The casing of a 5.25 measures 5.25 inches on each side. The disk itself is made of Mylar and is coated on both sides with a metal-oxide material. There is an oval shaped opening on one end of the disk exposing it to the elements. Also there is an index hole used to give the drive a starting reference point when the disk is spun.

The disk is held by the center clamping rings. On the disk there should be reinforcing hubs to insure a good grip by the clamping rings. If not, the disk may spin irregularly.

Some cheaper disks have a no hub. If you experience problems reading data from these disks, try adding a reinforced hub ring.



**Figure 1:** Typical 5.25 inch disk

The 3.5-inch disk is made of the same material as the 5.25 disk. The housing differs from the 5.25 disk. The 5.25 disk housing is soft and flexible. The 3.5-inch disk housing is rigid, less easy to bend.

The disk opening of a 3.5 disk is covered by a metal door that is pushed out of the way when the disk is inserted into the disk drive. This cuts down on the amount of dust that can get on the surface of the disk. The disk is not grabbed but sits on a center pin and is turned by a drive pin.

### Head Movement

In a disk drive, one of the two heads will move up and down. This motion is used when loading a disk in a drive. The upper head pushes the disk toward the lower head. This happens when the disk is inserted into the drive and the head control is closed (for 5.25-inch disks). The disk grasping mechanism grabs hold of the disk.

For a 3.5-inch drive, the disk is inserted and drops down onto the center pin. The drive motor (which is directly below) spins until the disk drive hole is caught by the drive pin. The slide cover is also opened as the disk is inserted into the drive allowing the heads to come in contact with the disk.

### Drive Motor

The main drive motor turns the floppy disk at about 300 RPM. The speed remains constant for most drives. Some drive motors vary the speed depending on where the head is located. The drive will spin slowest at the center and fastest at the outer edges.

Some drives have a pattern stamped on them to test the RPMs with a strobe unit. There will be usually two patterns, one for 50 Hz and one for 60 Hz. In the U.S., make sure you are reading the 60 Hz. The lines should not appear to move (or very little) when viewed. If so, a trimmer pot will need to be adjusted.

### Stepper Motor

The drive head for floppy drives is controlled by a stepper motor. This motor causes the heads to move across the surface of a disk in steps to read the tracks on the disk.

Figure 2 shows how tracks and sectors are arranged on a floppy disk. Each concentric ring of the disk is known as a “track”. The tracks are numbered from 00 to as high as 80, with the outer portion of the disk always labeled as track “00”.

Each track is broken into subparts called “sectors”. Sector reference can refer to a part of a single housekeeping function of the drive.

The index sector detector information is used to indicate the start of a track. These index characters are written after the disk detects the index hole in the disk.

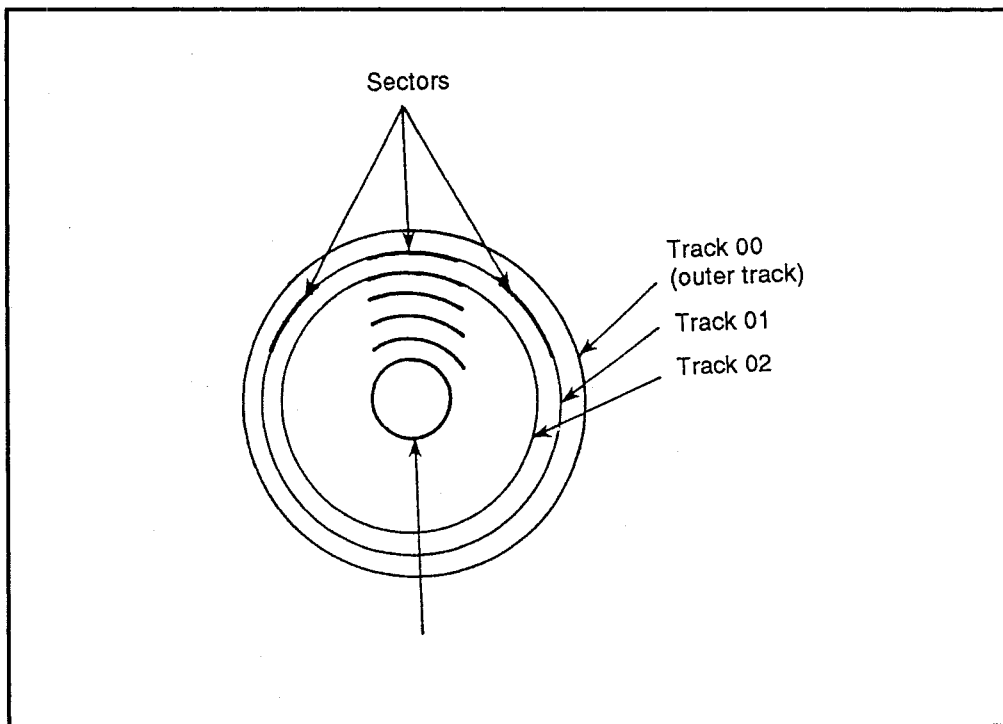
Sector data or ID blocks allow the drive to identify the sector being read. The data block contains the data being stored in that sector. This data contains information about the sector like the track number, side of the disk, the sector number, and the sector length.

The last two characters in the ID block are the error checking codes. They are called the cyclic redundancy check (CRC) which, simply put, adds the total of the sector as stored, and when retrieved, the total must equal this number.

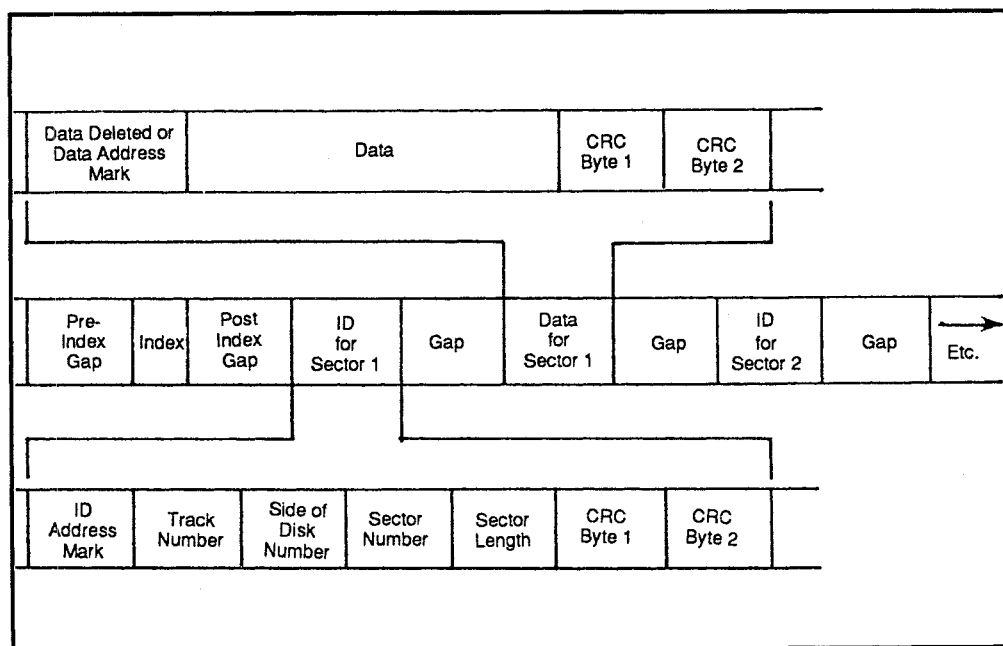
### Intermittent Read/Write Problems

If a floppy disk has intermittent read/write problems, it may mean that the heads are dirty. It could be (although less likely) that the alignment has changed. Clean the drive heads with a head cleaner. These disk cleaners will be a wet/dry system that removes particles from the drive heads as the disk spins.

If the drive can read disks it has written, but can't read disks that were written on other drives or older written disks, there is an “interchange” problem and the disk drive will need to be aligned.



**Figure 2:** Disk tracks and sectors



**Figure 3:** Track format

Some intermittent problems can be caused by poor operating procedures. Turning a computer off with a disk loaded (or the drive door closed so the heads are in contact with the disk) can damage a disk. When you first send power to a disk drive, it waits a few seconds to initialize the various circuits. A short amount of stay-data pulses may be sent through the disk head causing written changes to occur on a disk. Always open the disk drive door, or remove the disk when powering the unit off or on.

### Interchange Problems

To do an alignment, you will need an alignment disk, exerciser program, and a good oscilloscope. Before using an exerciser disk, it will need to sit at room temperature for about 20 minutes. Floppy disks change dimensions slightly as the temperature changes.

There are some exercisers that can be purchased that plug onto the disk drive connector and exercise the drive (or cause it to spin) without the use of software. With the exerciser (software or hardware based) you can step the head in and out, check the motor speed and check the head alignment.

Some alignment disks can be bought for about \$50. Others may be quite expensive, depending on the drive manufacturer. The alignment disk will be write protected, but when checking the drive if you manage to short the right pins on the drive board, you can write to the disk. Be careful.

The scope will need to be able to measure frequencies up to 30 MHz with dual trace. This will be needed to do the "head radial alignment" adjustment and the "index sector adjustment".

### Rotation Adjustment

The first adjustment to be made will be the drive RPM check. The RPM of the drive should be 300 RPM  $\pm 5\%$ . There may be a software routine that can check the speed of the drive. Refer to the drive specifications for the proper pot with which to adjust the speed.

On those drives that do not have strobe patterns on the drive, you will need to use a frequency counter to check the motor speed. The drive documentation will indicate the best points for determining the speed.

### Head Radial Adjustment

Head radial alignment assures that the disk drive head is positioned directly over the center of each track that it is reading. If the head drifts to one side of the track, the output from the drive will be unreliable.

This adjustment can be overdone and made to read the wrong track, so work carefully.



To do the head radial alignment, use the dual-trace scope. The vertical and sweep controls will typically be at 50 mV and 20 ms (depending on the drive and drive manual). The trigger will be connected to the sync test point of the drive and each channel will be connected to each of the head test points. Again, refer to the drive manual.

The computer should then be turned on and the exerciser program executed. The alignment disk is then inserted in the drive. The exerciser program is told to move the heads to step to one of the tracks that is recorded within the center of the alignment disk. On the scope should be a pattern as shown in Figure 4.

The head radial alignment is different depending upon the type of drive. The mechanism is adjusted while the drive is spinning and the results watched on the scope to achieve a waveform like that of Figure 4 (a).

### Track Zero Sensor

The track zero sensor adjustment will not vary with normal use. The systems employed may either be a small micro-switch or a track zero sensing mechanism which uses a photo-detector switch. Both are shown in Figure 5.

The switches can be checked with a DMM or logic probe. A logic probe will be connected with the two leads to the +5 VDC and ground source on the disk drive. The micro-switch can be checked with a simple continuity check.

Turn on the computer and start the exerciser program. Instruct the computer to step the Read/Write head from track 0 to track 5 and back again. Watch the results with your logic probe. If the output on your test pin is "high" when the head is at track 0, it should go low as the head passes between track 2 and 3 (or the reverse).

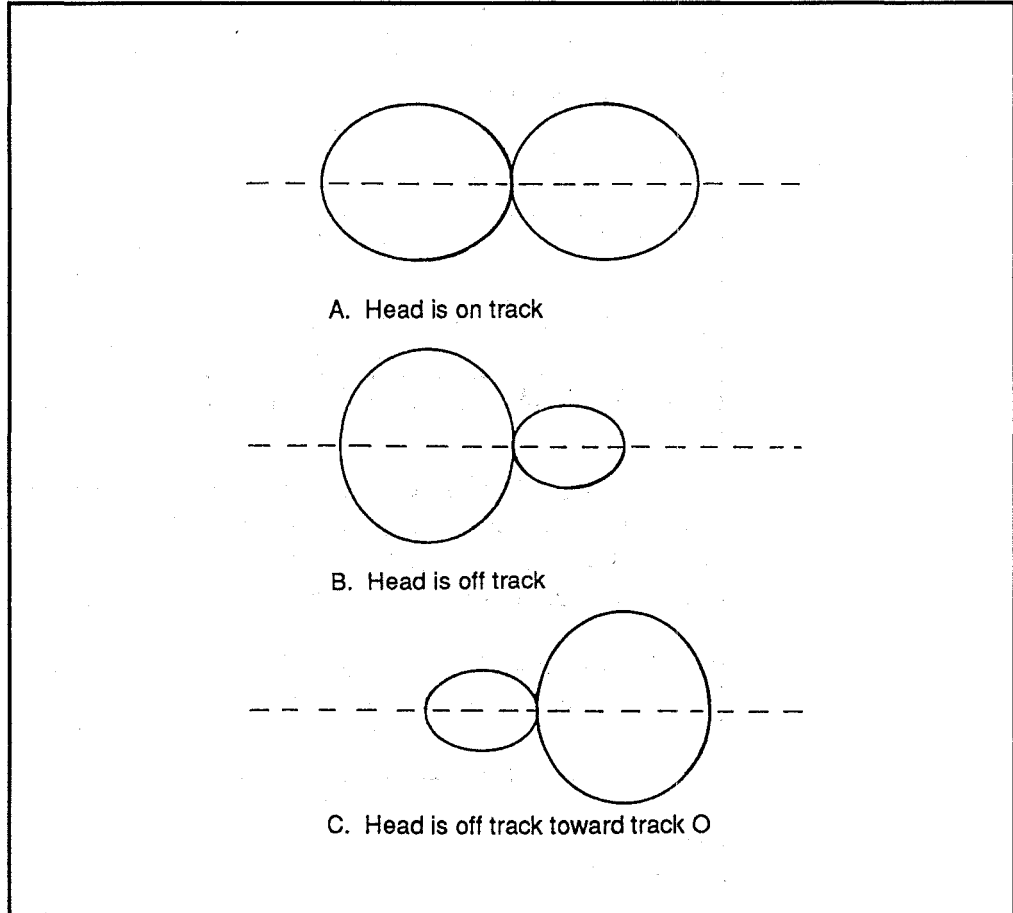
It is possible that the switch is working and the drive head is not located over track 0. If this is so, check the positioning of the head with the oscilloscope and check the alignment. The disk manual will indicate the correct placement of the oscilloscope probe.

### Carriage Stop

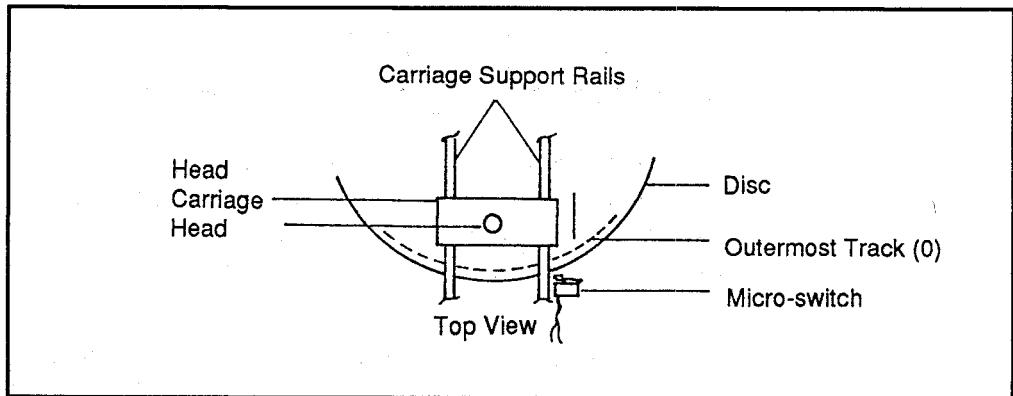
The carriage stop for most drives is some kind of sensor an arm passes through or a bumper that stops the carriage from slamming into the end of the travel rods. Usually this will not need to be adjusted, but if there is a problem, refer to the service manual for proper setting of this device.

### Index Hole Adjustment

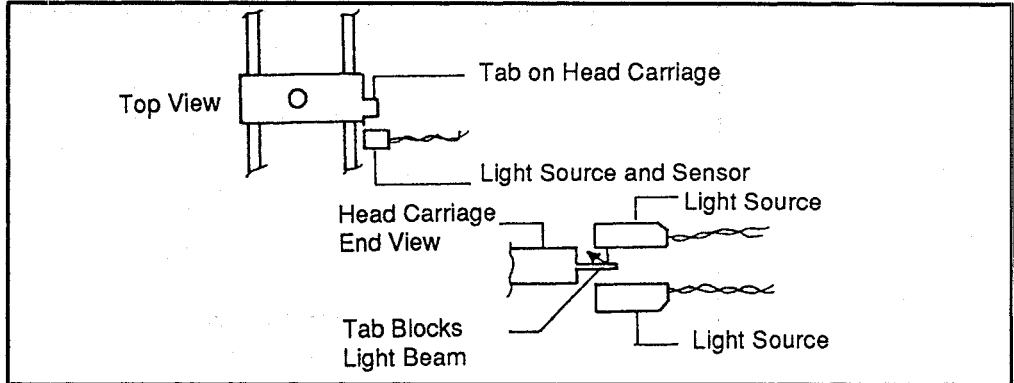
The head load adjustment tells the disk drive where the starting point of the spinning disk is. On some drives (5.25-inch drives) there is a physical hole in the disk used to reference the index point. Some drives may not use this hole and require



**Figure 4:** Head radial waveforms: (a) head is on track (b) head is off track toward track 0 (c) head is off track toward inside track



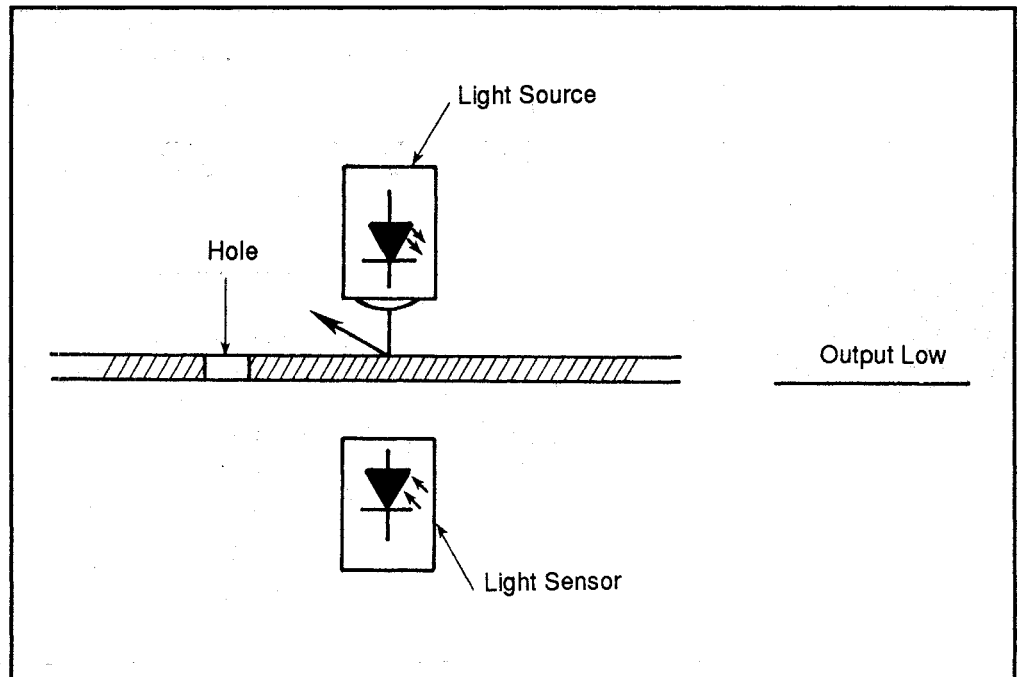
**Figure 5a:** Zero track mechanisms: micro switch sensor



**Figure 5b:** Track zero mechanisms: light source and detector

no adjustment. The index timing mechanism is very simple. An LED or infrared light source is mounted on one side of the disk and a sensor on the other. Light is passed through the hole each time the hole passes the sensor. This will occur once with each revolution. Then an index signal is sent out.

To align the index timing, you will need to use the scope. Typical settings for the vertical control is  $-.2 \text{ V/div.}$  and the sweep set is  $50 \text{ ms.}$  The scope is set to



**Figure 6a:** Index timing mechanisms and waveforms

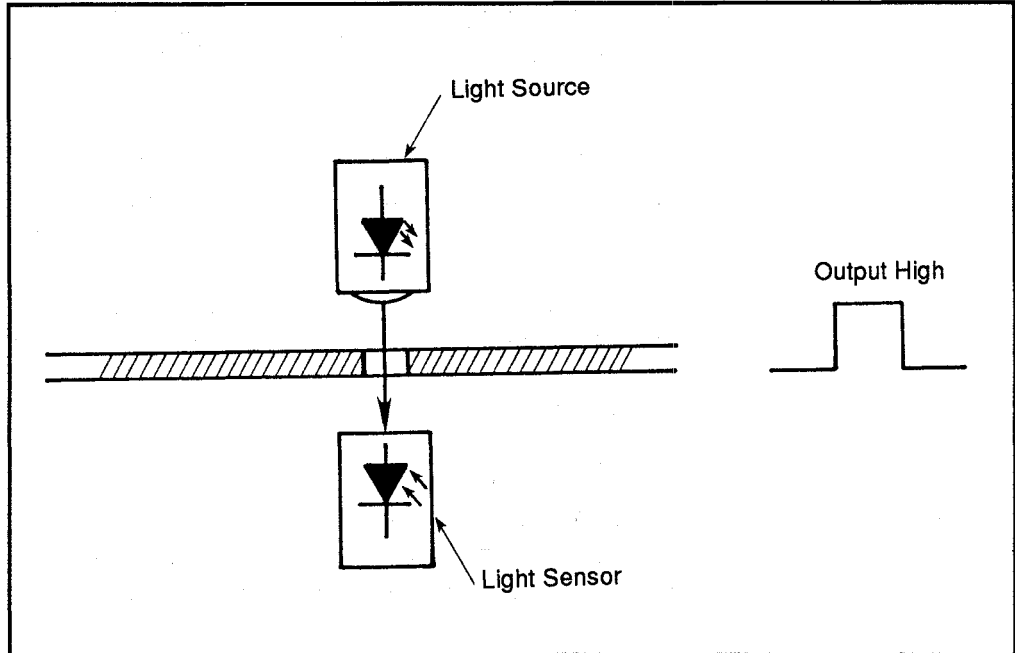


Figure 6b: Index timing mechanisms and waveforms

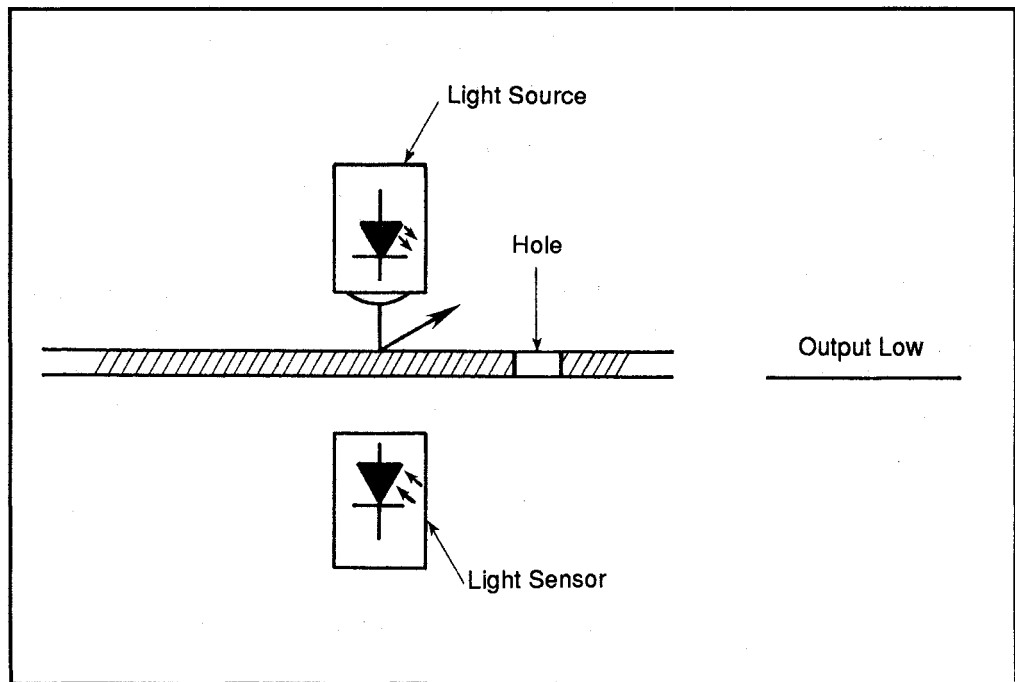


Figure 6c: Index timing mechanisms and waveforms

add channels A and B and invert the B channel. The scope is triggered by the drive as reference in the drive service manual. The channels are connected to the two head test points, with the probes properly grounded.

The exerciser program is loaded and the alignment disk inserted. The drive is instructed to read the track on the alignment disk that carries the test signal for this test. The scope trace should look like those in Figure 6.

The alignment can be made by moving either the light source or the photocell. Either one of these may be able to be moved, physically by loosening screws that attach them. One screw should be slightly loosened and the part moved until the waveform is correct.

### Raw Data Checks

The raw data test (if available) will require the use of a “scratch” disk. This is a blank disk that can be written to and read from (or any disk you don’t mind losing the data on). The scope is connected with the test for head radial alignment. The disk drive service manual will specify the correct scope settings.

The exerciser program is told to run the raw data test. The computer will write and read a pattern to the disk that will be displayed on the scope. The two waveforms should be very close. The manufacturer of the drive will specify the correct tolerances for the drive. If the waveform shows a blurred area larger than specs allow, there may be something physically wrong with the drive. Check for mechanical problems.

### Azimuth Checks

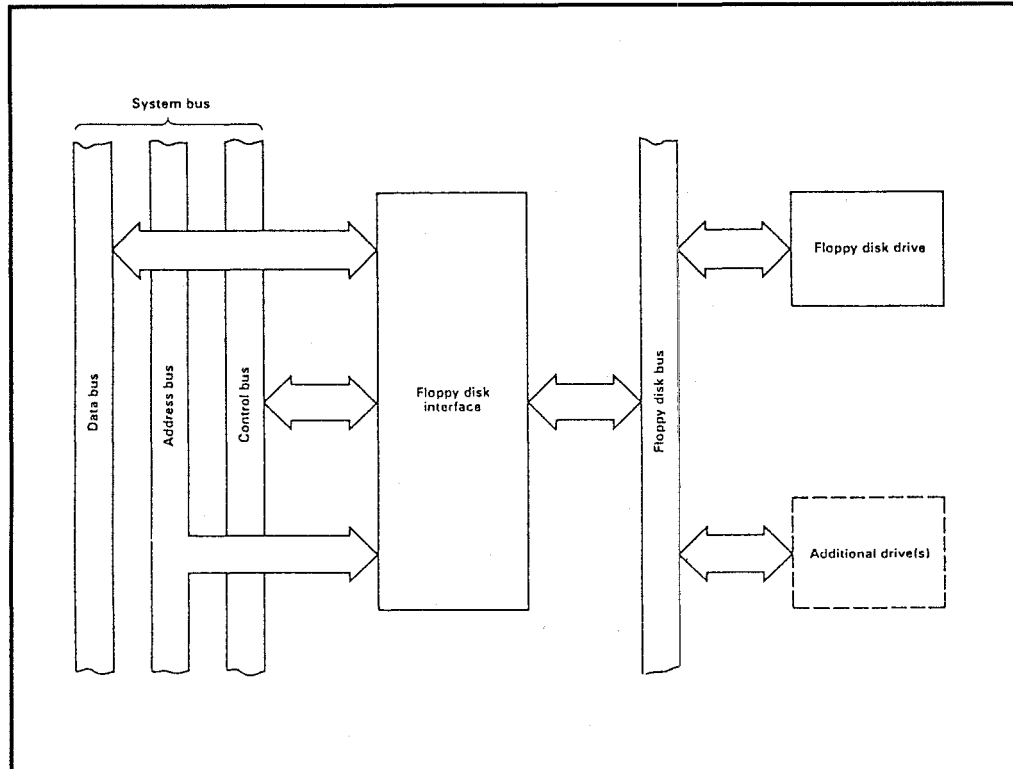
When the disk head is positioned correctly, the center of the head should lie at an angle of 90° to a line drawn to the center of the disk. This alignment can be thrown off if the head has been moved sharply such as by dropping the disk.

The disk drive manual will specify the correct setup for the azimuth position. If the azimuth can’t be adjusted to within tolerance, the head will have to be replaced. Often this means that the entire drive should be replaced, as the cost of a new drive is only slightly more than a head.

If the azimuth is off by more than a few minutes (a sub-division of a degree) one way or the other, the azimuth is incorrect. Signals that occur from the test may vary from one type of drive to the next.

## Tests for Floppy Mechanics and Individual Circuits

Various sections of the drive could be at fault when a drive is not responding the way it should. These are discussed below.



**Figure 7:** Floppy drive connector

### Cables

All the connecting cables should be continuity checked using a DMM. The cables' status should be determined before tearing into the various areas of a floppy drive.

### Drive Motor Spindle Test

The drive motor and spindle may be causing many of the alignment problems. The spindle should turn smoothly, with no catching or resistance. (With some drives, you may be able to manually rotate the spindle several turns when no power is applied.)

The bearings for drive motors are sealed and permanently lubricated. If there is a rough feel or grinding sound as the shaft is turned, the bearings have gone bad. If so, the motor should be replaced. (As with head replacement, the cost of a new motor is often nearly the same as a new drive).

The drive motor and spindle are fed a regulated voltage to maintain constant rotation. If the regulator becomes faulty, the motor will not spin at a constant speed. Check the voltage output of the regulator circuit.

Most drives use a tachometer device to detect the speed of the disk. In some drives there will be a tiny magnet mounted in the spindle. With each spin, the magnet passes a pickup which generates a pulse. These pulses keep the drive spinning at a constant speed.

### Stepper Motor Test

It's rare for a stepper motor to fail. Testing it for proper function is a matter of checking the stepper logic.

The stepper logic and stepper motor cause the Read/Write head to move in and out on a disk. The stepper motor causes the head assembly to move in precise increments.

To check the stepper motor, start the exerciser program. The drive should be instructed to step in and out. If the Read/Write head does not move, check to see if there is an obstruction preventing the movement.

Next, check the lines that carry the signals from the control circuits in the computer to the stepper logic circuits in the drive. The direction signal specifies whether the head will step out or in (either a true or false logic signal). The stepper should be stepped in both directions with the software. With an oscilloscope you can view the signals being sent to the stepper motor's four lines. Each of these lines should show some activity.

If any of the lines are missing data, the discrete component feeding the bad line should be checked. This will be a transistor of some kind.

### Write Protect Test

The write protection system is a simple switch which disables the write circuits. On a 5.25-inch disk, there is a notch which a physical arm or light sensor detects. If this notch is not present, or is covered, the disk is protected.

3.5-inch disks will use either a light sensor or contact switch. If the hole is covered (closed), the disk can be written to, and if uncovered (open) the disk is write protected.

It is possible for the write protect to become jammed and not allow any writing. This will almost always be caused by a faulty switch or light sensor. Check the alignment of the write protect switch, or light assembly in relation to a loaded disk. The two should line up. If they don't, the write protect assembly should be adjusted.

### Read Circuit Test

To check the read circuits, start by visually examining the heads for score lines or scratch marks. If the heads show visible signs of wear, the best solution is to

replace the drive. As above, the replacement heads are nearly as expensive as a new drive. In this case, if the heads are badly worn, other parts are likely to be aging as well.

Bad heads will fail a “head output test”. Set up the scope as in the head radial alignment adjustment. The exerciser program should be loaded and a scratch disk put in the drive. The program should be instructed to write a series of pulses onto the scratch disk and then read back. View the amplitude of the signal display on the scope. Place a 1/2 ounce (about the weight of a quarter) weight on the arm directly above the load pad or the upper head. View the scope trace. The amplitude of the output pattern should increase slightly. If the increase in amplitude is greater than about 10%, the drive should be replaced.

### Write Circuits

Check the control signals of a typical write circuit. These may be the write gate, write data, and write protect signals. If the inputs are okay, look at the logic and driver circuits. There may be two of these circuits for each side of the head coil.



**9/PC**Personal  
Computer

9/PC - TR	Troubleshooting and Repair
9/PC - TR - HD	Hard Disk

## 9/PC - TR

### Troubleshooting and Repair

## 9/PC - TR - HD

### Hard Disk

**Cable**

Hard drive controller cables, when used with two drives, will have a 34-pin controller cable similar to floppy drive cables, but will have a twist that starts 5 wires from the end (opposite from the different colored wire) and is five wires wide. Interchanging the floppy cable with the hard drive cable will be a source of many problems.

Problems with the hard drive will be indicated by 17xx codes. If problems with the hard drive are suspected (drive, controller, or cable), the best test is to substitute equipment that is known to work properly.

**Installation/  
Configuration**

Check for proper installation and configuration. For AT controllers, the drive must be listed in the CMOS memory. If it's not, the drive will be reported as absent. XT controller cards (8 bit) on AT machines require the CMOS setup be told no hard drive is present in order to work. Boot from floppy to run hard drive diagnostic programs or to run the CMOS setup (for ATs) hard drive diagnostic program.

**Alignment**

If there is an actual problem with the hard drive, no steps other than alignment are possible. The drive will have to be shipped to a qualified hard drive repair place. Internal work on the disk, or disk heads requires a "clean room" environment. Opening the hard drive outside such an environment invites disaster.

**Common Hard  
Disk Problems**

Common hard disk problems are listed on the following page.

SYMPTOM	CAUSE	FIX
<b>Drive motor not turning.</b>	Power supply.	Check supply.
	Defective drive motor.	Replace drive.
<b>No read or write.</b>	Power supply fault.	Check supply.
	Head not stepping.	Check hard disk controller, cable connector.
	Read/write head faulty, dirty or worn.	Replace drive.
<b>No read.</b>	Read amplifier .	Check read amplifier
	Disk controller fault.	Check controller.
<b>Intermittent data error.</b>	Speed irregular.	Replace drive.
	Defective disk.	Replace drive.
<b>Hard disk crashes after some time.</b>	Low level format.	Reformat after normal temperature has been achieved.
	Inadequate cooling.	Check cooling fan and ventilation.
	Mechanical shock.	Don't submit the unit to shock or vibration.

## 9/PC - TR

### Troubleshooting and Repair

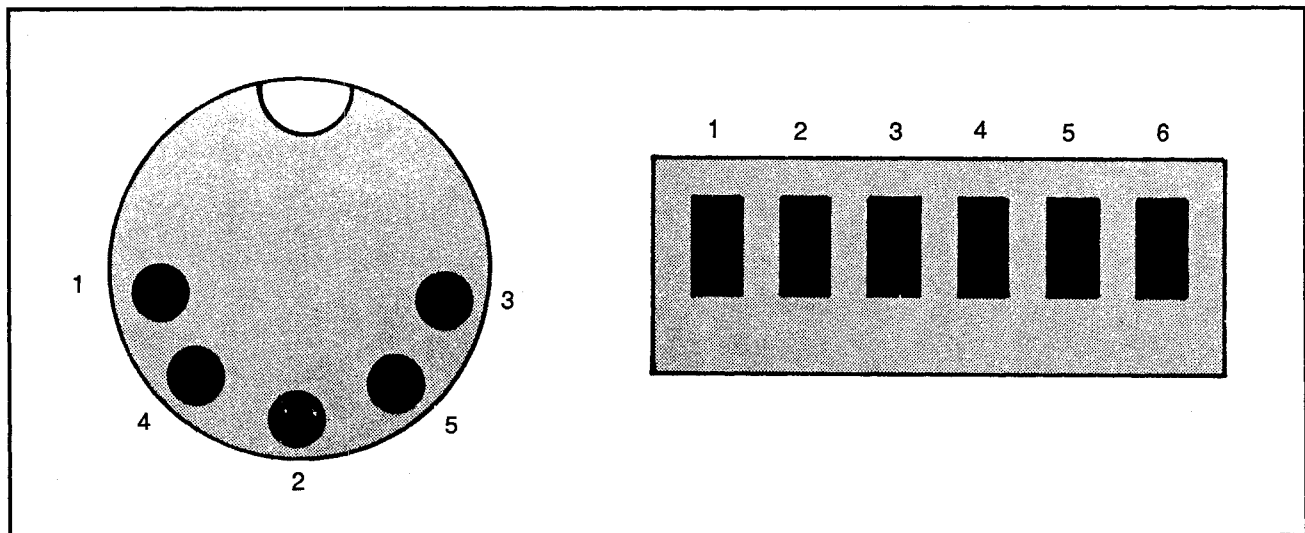
## 9/PC - TR - K

### Keyboard

Keyboard errors may be difficult to detect. When a computer is turned on, the POST tries to locate and check the keyboard. If an error is found, a 3.xx code will be reported. (Check Section "12/I-PC-PROP" for the various code listings.)

#### Power

The pin arrangement is shown in Figure 1. To check the keyboard power, turn the computer off, disconnect the keyboard and then turn the computer on again. Check the voltages at the system board keyboard connector. If the measurements are different than listed, the motherboard may be defective.



**Figure 1:** Keyboard connector pin arrangement

#### Cable

If the power ratings are correct, the keyboard or cable may be defective. Try a different keyboard to see if it works on the computer. Otherwise, replace the cable for the keyboard, or check each wire for proper connection at the din plug on the keyboard cable and inside the keyboard. (Use a DMM with continuity checking.)

9/PC - TR	Troubleshooting and Repair
9/PC - TR - K	Keyboard

### Lubrication

In the event of one or two keys having problems, first clean the key(s). Lubrication of newer keyboards is not easily possible. The keys are mounted on rods that are surrounded by a spring-load with a foam center and a foil contact. Lubrication may damage the key striking arrangement.

### Switching Mechanisms

Key mechanisms are often the most unreliable part of a computer system. Various mechanisms have been devised in an effort to improve the various problems related to the key mechanism. So far, each method of key striking seems to work just as well as another, and each will eventually wear out, or become dirty and require maintenance or replacing.

If you are working on a unit with mechanical contacts, and there is a build-up of dirt or corrosion on the contact points, this will probably be the cause of problems. Mechanical contacts can be cleaned with a TV-type contact cleaner.

If one key is causing problems due to dirt and corrosion, the chances are there are other keys causing problems too. Plan on cleaning all the keys, or replacing the keyboard.

### Removing Keys

Keys from most keyboards cannot be removed from the top easily. Gentle prying with a screwdriver may be necessary to remove the keys so you can access the key mechanism for cleaning. A common trick is to bend the end of a paper clip into a hook to lift the key cap. Regardless, be sure to note the position of the keys before you remove them.

Oversized keys such as the the spacebar, shift keys, and the enter key will have a single mechanism and spring system to keep the key balanced on the key mechanism. Removal and replacement of these can be very frustrating, but with practice (and patience) can be accomplished.

Once the keys are removed, you can clean the internal contacts and lubricate them by spraying a small amount of cleaner/degreaser on the key shaft. Be careful with the type of keyboard. In the foam and foil model you may end up destroying the foam, making the key worse than it was. (Disassembly of one of the key mechanisms may be possible to determine the type of key mechanism in use.)

9/PC - TR	Troubleshooting and Repair
9/PC - TR - PS	Power Supply

## 9/PC - TR

### Troubleshooting and Repair

## 9/PC - TR - PS

### Power Supply

#### Power Measurements

If power supply problems are suspected, you must make measurements while the supply is still in the computer, and hooked up. PC power supplies are “Switching” power supplies. There must be a load present, or the supply will shut itself down. There must be at least a motherboard and one disk drive hooked to the supply to test it. The pin voltages for the power supply connectors are shown in Figure 1.

The easiest method to assure that the power supply is at fault is to check the power at the leads connected to the devices. (For example, probe the test points where the power supply connector plugs into the disk drive.) If after this you still suspect a power problem, swap the power supply with another one that is equal or better. Power load testing may be pulled down from a faulty component on the mother board, expansion slots, or one of the peripherals.

If there is an internal problem with the power supply, your choices are to swap the supply for a new one, or attempt to repair the supply. Power supplies are relatively low-cost repairs to PCs which may warrant replacement rather than a costly, lengthy search.

#### Accessing the Power Supply

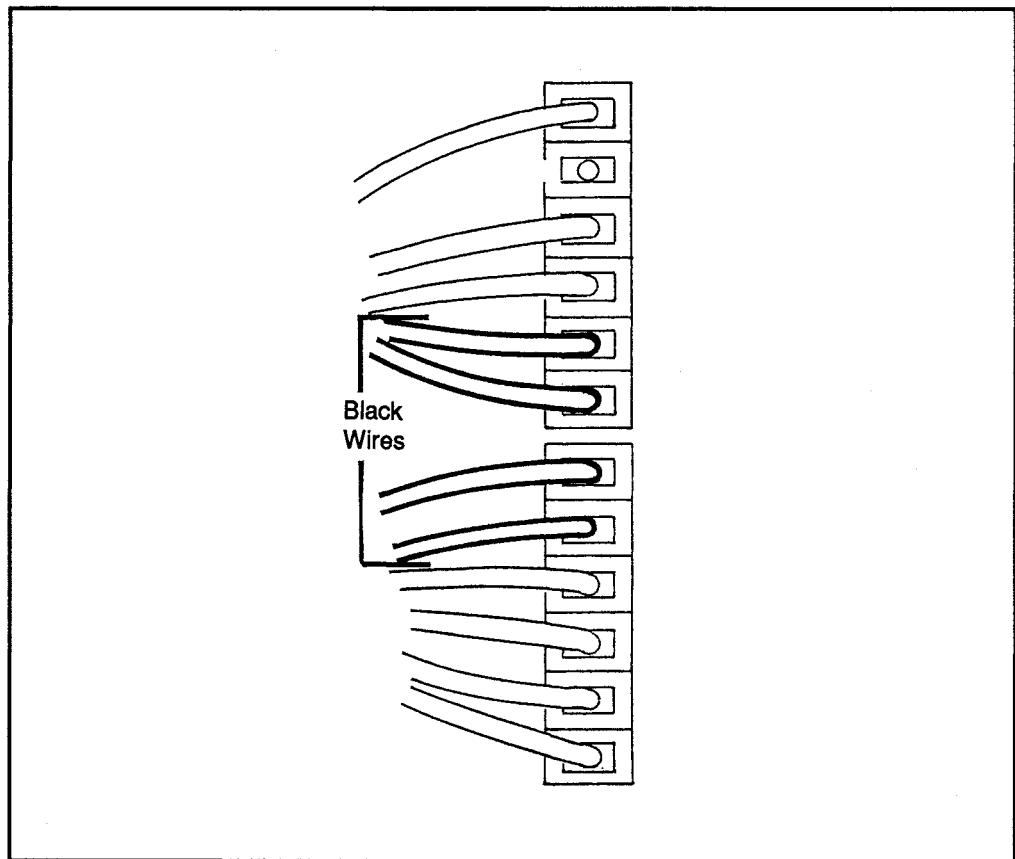
To access the internal components of a power supply, remove the supply from the case. The power supply will be held in most PCs by four screws at the back of the computer and two clips on the bottom. Disconnect all connectors, remove the four screws and slide the supply forward and lift out. You may have to remove disk cable connectors or even the disks to get the power supply to come out.

To open the supply after removal, you will need to remove several screws. This is dependent on the power supply. (Some are sealed and cannot be accessed.) After accessing the inside, you cannot test the power supply in the ON mode unless you apply the needed load (e.g., a motherboard and one drive). Standard

component checking can be done with a DMM, capacitor checkers, transistor checker, and resistance checker.

If the power supply is functioning normally, or is being pulled down by some other part of the computer, you will need to begin removing items that require power. Start with the drive units, as these will tend to fail first. (Always leave one drive connected to the power supply or the power supply will automatically shut down.)

Next, begin removing various expansion boards. Try to remove those boards not essential to power-up the computer first. The minimum required boards will be the motherboard and a video board. The video board can be removed if you are only checking the power output of the supply.



**Figure 1:** Power supply connectors

9/PC - VCS	Various Case Studies
9/PC - VCS - 286	286 Computer System

---

## 9/PC - VCS Various Case Studies

---

## 9/PC - VCS - 286 286 Computer System

---

### Introduction

A case study on the 286 computer represents the repair of most of the PC line. That is, with minor changes, the information presented here can be used to repair the 386 and 486 machines. This section deals with the IBM AT-286 machine.

Most PC lines at the AT level and above (286, 386 and 486) have built in CMOS diagnostic routines used to troubleshoot the computer. If the computer is up and running, but has faults, this software can help locate problems and aid in the repairing of them. If this diagnostic software is not enough, third party software is available. These third-party software programs will often go beyond the supplied diagnostic troubleshooting routines.

The Power On System Test (POST) covered in Section "9/PC - TE" general PC repair and maintenance section applies fully to the 286 machine. In fact, the POST applies to most IBM related PC clones as well as the official IBM PC line.

**The System Board** The system board for the IBM 286 uses the Intel 80286 microprocessor. The system board layout is shown in Figure 1. The board has a 7-channel Direct Memory Access (DMA) capability with a 16 level interrupt line. Unlike the predecessor, XT and PC models, the board has a built in system clock and a real time clock. There are three programmable times on the board.

The board can hold either 256 Kb chips, or 1 Mb chips. There is also a CMOS complementary metal oxide semiconductor) memory RAM to hold the system configuration and diagnostic information from the onboard diagnostics. The CMOS memory is battery backed-up by either a fixed 3 V battery or a battery in a removable battery holder.

The board has 8 input/output (I/O) slots. From these 8 slots, six are designed for 16-bit technology (a 36 and 62 pin edge connector) and the remaining two for 8-bit cards (62 pin card edge sockets).

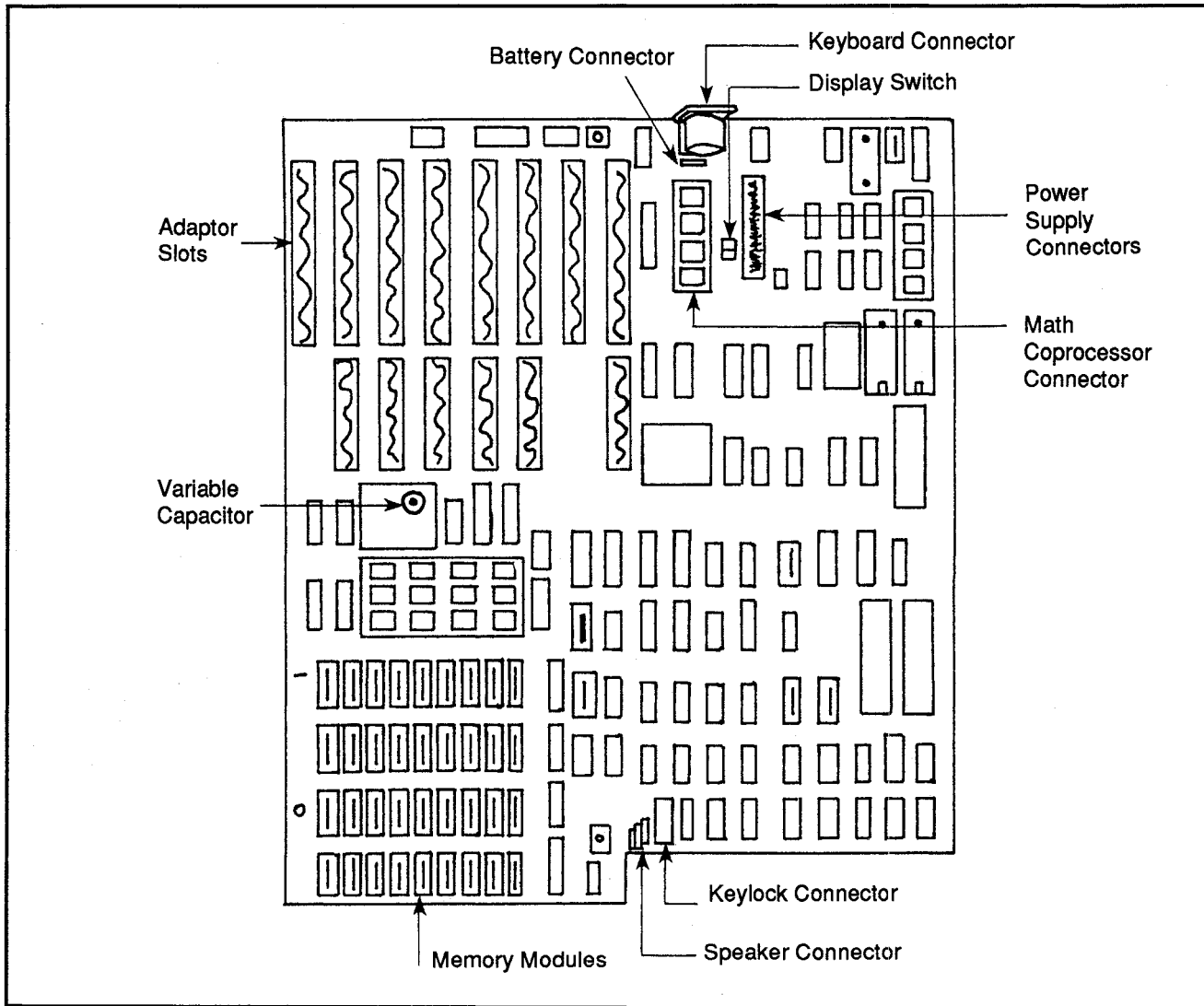


Figure 1: System board layout for IBM 286

**Microprocessor**

The 286 microprocessor has a 24-bit address line, and a 16-bit memory interface with an extensive instruction set, DMA and interrupt support capabilities, a fixed-point multiply and divide section, memory management section, a four-level memory protection, and a virtual address access range of 1 Gb of memory.

In the real address mode the physical memory is a contiguous array of up to one megabyte. This allows complete backwards compatibility with the 8086 processor and most DOS-related software.



9/PC - VCS	Various Case Studies
9/PC - VCS - 286	286 Computer System

In the protected mode, the processor can offer extended physical and virtual memory address space, memory protection mechanisms and some new operations to allow support for the operating systems and virtual memory. This protected mode allows access of up to 1 Gb of the virtual address space per task mapped into a 16 MB physical address space.

## Troubleshooting and Repairing the 286

### Tip

In all steps that follow, keep in mind that you should never make or break any connection while power is flowing. This is especially important when it comes to the plug-in circuit boards. If one must be removed or replaced for testing, completely shut down power.

All basic troubleshooting for the IBM 286 (or for any of the PC series) begins with turning the unit on and running the diagnostic routines. The computer is a marvelous tool for self diagnostics and troubleshooting. If you cannot get this far, it is due to either a power problem or a serious component problem. In such cases, the POST commands can still be your guide. If you cannot get the unit to start, you will need to fix or swap the power supply.

### Power Supply

The IBM PC power supply can be operated at either 60 Hz or 50 Hz and can be operated at either 120 VAC at 5 A, or 240 VAC at 2.5 A. The voltage is selected by a switch that is located above the power cord connector at the rear of the AT.

The output from the power supply provides +12, -12, +5, and -5 VDC. If output becomes overloaded (for example, shorting any of the many power leads on the system board), the power supply will switch off within 20 ms. This will protect the power supply from an overload condition and perhaps many of the components of the computer as well.

The power supply requires a dummy load to be connected to P10 when a hard drive is not present. The dummy load is a 5 ohm, 50 watt resistor.

If there is no load present on any of the connectors, the power supply will not be damaged. In this case, the power supply will simply not switch on. There must be a minimum load (the system board) for the power supply to switch on.

When the power supply is switched off for at least one second (preferably 5-10 seconds) and then switched on again, a power good signal is generated. This occurs only when there are no problems in the power supply or connected items.

9/PC - VCS	Various Case Studies
9/PC - VCS - 286	286 Computer System

The connectors used in the IBM PC power supply are listed below:

Load Point	Voltage (VDC)	Maximum Current (A)
PS8-1	Power good	N/A
PS8-2	+ 5	3.8
PS8-3	+ 12	0.7
PS8-4	- 12	0.3
PS8-5	Ground	0
PS8-6	Ground	0
PS9-1	Ground	0
PS9-2	Ground	0
PS9-3	- 5	0.3
PS9-4	+ 5	3.8
PS9-5	+ 5	3.8
PS9-6	+ 5	3.8
P10-1	+ 12	2.8
P10-2	Ground	0
P10-3	Ground	0
P10-4	+ 5	1.8

**Note:** P11, P12 and P13 are the same as P10.

If the power supply does not start, set the system unit power switch to off. Remove the cover for the 286 and set it aside. Use the DMM with the voltage range set to measure 20 VDC and less. Connect the black probe (common) to pin 5 of P8 and the red probe to pin 1 of P8.

Turn the power supply on. There should be a reading between 2.4 and 5.2 VDC. If there is, continue to check the rest of the connectors.

Figure 2 shows the arrangement of P8 and P9 on the system board and Figure 3 shows what one of the other remaining connectors appears as.

The following shows the voltages that should be found for the connectors.

### System Board Connectors

Min VDC	Max VDC	+Lead	-Lead
+4.8	+5.2	J9-4	J8-5
+4.5	+5.4	J9-3	J8-6
+11.5	+12.6	J9-1	J8-3
+10.8	+12.9	J8-4	J9-2

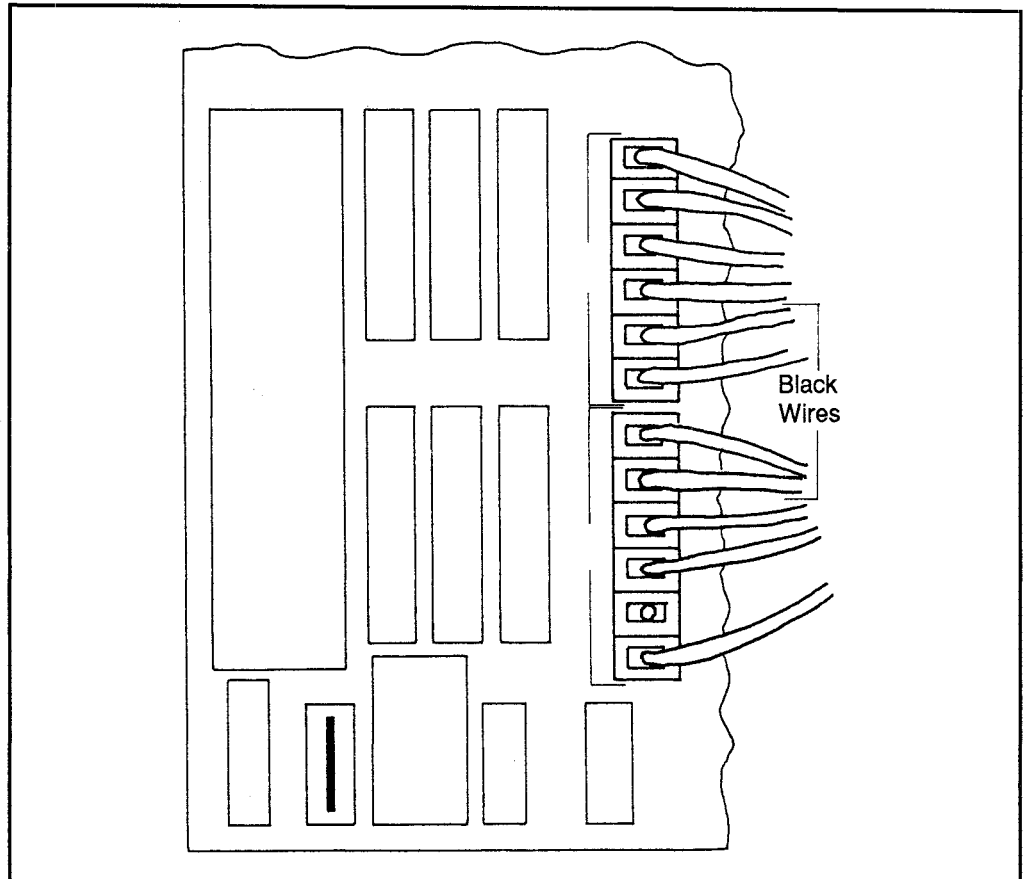


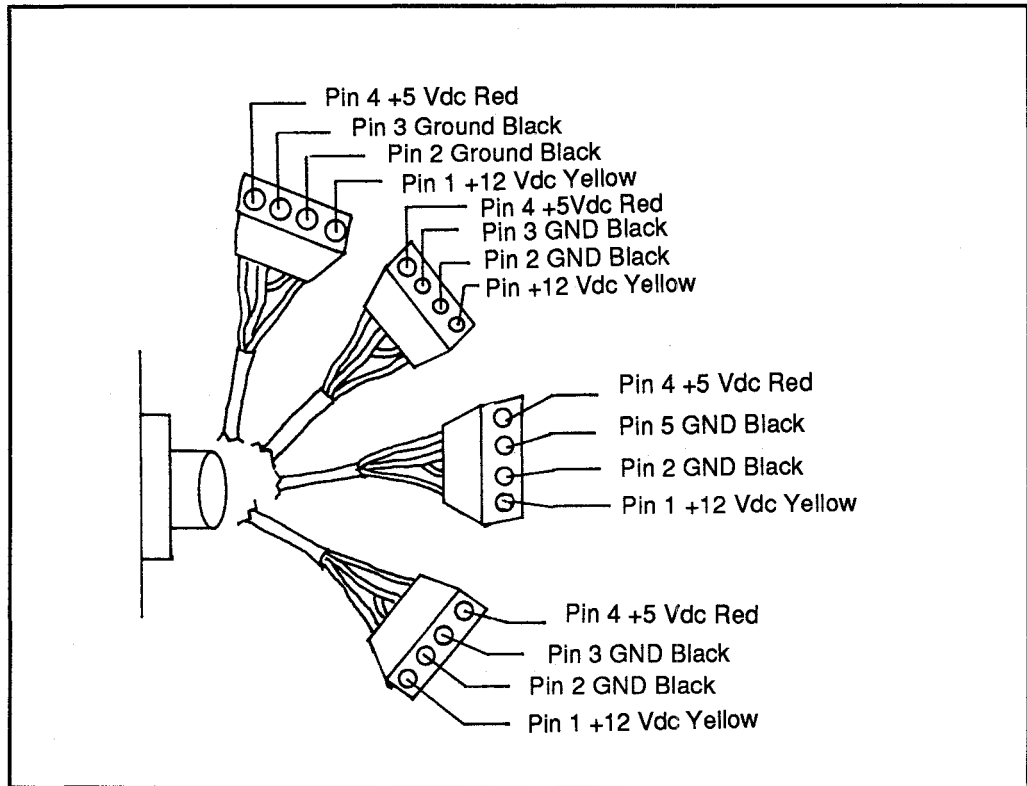
Figure 2: System board connectors P8 and P9

**Other Connectors**

Min VDC	Max VDC	+Lead	-Lead
+4.8	+5.2	2	4
+11.5	+12.6	3	1

If the system board power supplies are not at the correct voltage, replace the power supply. If any of the other connector voltages are incorrect, the power supply should be replaced.

If the power problem still remains, disconnect all drives and try turning the unit on again. Remember to use a dummy load on one of the connectors when removing the connector from the hard drive. If the power problems have been corrected, one of the drives is causing the voltage to be pulled down and should be replaced. To locate the faulty drive, reconnect each drive independently and try the power again.



**Figure 3:** Other power supply connectors

Another power problem may occur from a failing math coprocessor (if one is present). Turn the power off and remove the coprocessor from the system board. The use of an IC puller is best for this, but a small flat head screwdriver can be used to gently pry on each end to loosen the chip from its socket. If the power problem was corrected, replace the chip.

The next step requires removing the primary display adapter from the system board. Locate the video board and remove it. This will cause the system to go into the POST. Turn the system on and listen for one long and two short beeps. If they occur, replace the video adapter. If this does not correct the problem, replace the system board.

Before replacing the system board, be sure that the problem does not stem from any other boards in the expansion slots. Remove all but the necessary boards from the slots (everything but the video board). If the problem is fixed, turn the power off and add one board. Then turn the power on. If the problem returns you have located the bad board. Replace the bad board. Do this for each of the other boards in the system.

**System Board  
Checking**

There are a variety of tests that POST will use to help spot and indicate a problem with the system board (assuming you can get that far). The screen will display a 1xx error message.

If you receive a 1xx message, replace the system board. The following refer to some of the Error codes that may be received.

If you received a 101 code, there may be a failing math coprocessor. Remove this chip and try again.

<b>Error Code</b>	<b>Cause of Problem</b>	<b>Error Code</b>	<b>Cause of Problem</b>
101	Interrupt failure	110	Replace system board
102	Replace system board	121	Replace system board
103	Replace system board	151	Battery defective or new battery installed
104	Replace system board	152	Replace system board
105	System unit failure	161	Battery defective or new battery installed
106	Replace system board	162	System options error. Run Setup
107	Replace system board	163	Date and time not set. Run Setup
108	Replace system board	164	Memory size error. Run Setup
109	Replace system board	199	Option setup error. Run Setup

**System Board  
Replacement  
Codes**

If you received a 102 to 109, 121 or 152 code, replace the system board. There is a problem that will be more difficult to fix rather than replace the board. Disconnect P8 and P9. Also disconnect any JP leads that may be found which lead to various controls like the key lock, speaker, turbo switch, power LED, etc.

To pull the system board, remove all cards in the expansion slots, drives located over the system board and all screws or nuts attached. On some boards there may be a single screw or nut located at the back near the power supply on the system board that will need to be removed, then the system board can be slid to one side and lifted out. Retain any standoffs on the system board to put on the new system board.

The system board could be checked for any broken leads or burnt components that could be replaced. This may save several hundred dollars in a board replacement.

**Code 151 or 161**

A battery that has gone bad, or has been replaced will cause an error message to occur. The system cannot operate because the default parameters running the system were stored in CMOS memory and are now lost. They will have to be

replaced each time the system is started, or a new battery is installed and the settings reset.

If the battery is able to be disconnected from a battery connector, do so. Check the voltage of the battery. The reading should be a minimum of 6 VDC for a 6 V battery and 3 VDC for a 3 V battery. Refer to the battery used in the system for the correct storage capacity.

**Math Coprocessor** If the math coprocessor is failing, an error code of 7xx will be returned. In most cases, the math coprocessor will come with a diagnostic disk to check the functioning of the chip. If not, use the built in diagnostic for coprocessor checking. If the test reports a coprocessor problem, or a 701 code is reported, replace the chip.

**Memory Problems** When the computer is started, POST will do a memory count to check that all memory chips are working properly. This test is a simple parity test to detect the presence of the chip and is not an extensive diagnostic test. You will need to run a memory check program that completely checks memory suspected of having problems.

If there is a memory size error, it can be easily corrected by running the setup program. This will reset the CMOS value stored. When a memory error message is displayed, the system will attempt to tell you the location of the bad IC. This will be a ten digit code. The first two characters tell the location of the error.

The first two characters indicate the bank in which the bad IC is located. Codes beginning from 00 to 07 indicate that the problem is on the system board (00, 01, 02 or 03 being Bank 0; 04, 05, 06 or 07 being Bank 1). The last four characters indicate the specific module that is failing. For example, if the error code is 020002 8000, the IC is located in Bank 0, the 15 position. The 8000 refers to the 15 location. The different codes for the last four digits follow:

**Last Four Digits**

0000 = P	0020 = 5	0800 = 11
0001 = 0	0040 = 6	1000 = 12
0002 = 1	0080 = 7	2000 = 13
0004 = 2	0100 = 8	4000 = 14
0008 = 3	0200 = 9	8000 = 15
0010 = 4	0400 = 10	

**Keyboard** If during the POST you have received a 3xx error code, there is a problem with the keyboard. Any obvious broken parts on the keyboard should be corrected.

Keyboard errors can occur when the operator has pressed a key before the computer “looks” at it, or if a key is stuck. Most often this key press occurs when the operator tries to get the system into the diagnostic routines before DOS has been started.

The diagnostic software will allow you to test each key of the keyboard and will display a representation of the keyboard on the screen. If any of the keys do not work properly, try to clean the key if possible. If more than a few keys do not work, replace the keyboard.

Check the connector cable for the keyboard and see if all the wires are working properly. If the internal cable is good, and the problem still exists, replace the keyboard.

It is possible that a static charge has blown the keyboard IC. In this case, there will be improper key strokes seen on the screen. Static discharge can occur if you are cleaning the surface of the video screen with one hand and touching the keyboard with the other. A static charge will be transferred from one hand to the other and possibly damage the keyboard.

If the code received was a 302 error code, unlock the system unit key lock and continue. If the system key lock is unlocked, check it with a continuity checker. When the key lock is locked, there will be no continuity.

If the code received was a 303 or 304, replace the system board.

### Display Adaptor

If at anytime when you start the computer you get an audible signal of one long and two short beeps, it will indicate there is a problem with the video display card. Remove and substitute the card with another to see if the problem is corrected. If not, check to see if the system board switch setting or the setup CMOS is wrong. If all are correct, the system board will need to be replaced.

### Diskette Error

Most disk errors occur because the CMOS setup is set for the wrong type disk drive match. For instance, if the CMOS is told that floppy disk drive 1 is a 360K floppy drive and you have a 1.44 Mb drive connected, you will be unable to read any of your disks.

POST codes received will be of the 6xx variety error code. The LED of the floppy (or both floppies, one followed by the other) will be lit before a beep occurs and the system starts.

The LED for drive 1 will come on and time out if no disk is present and proceed

9/PC - VCS	Various Case Studies
9/PC - VCS - 286	286 Computer System

to a hard drive (if present) to load DOS. If no system disk is present, the appropriate status error will be displayed.

If the drive does not light, then there may be a power problem to the drive. Turn the power off and open the case. Check the voltages at the drive A circuit board. The voltages should be between 2.0 and 5.5 VDC. The pins to check are 12, 16, 18, 20, 22, 24, and 32. If they are not at the specified voltage, replace the drive. Check for voltage readings on the disk cable with the cable removed from the disk. Pins 8, 26, 28, 30 and 34 should have voltages between 2.0 and 5.5. If not, remove the cable and check for continuity. If all the lines are OK, replace the drive.

### Serial/Parallel Adaptor Ports

If a 9xx code has been received, it means that either the serial or parallel port is having a problem. Run the diagnostic routine and check each of the ports. The use of a null modem connector or serial device may be needed to check the serial port. The parallel port will usually be checked through the use of a printer (the serial port may be hooked to a serial printer as well).

If errors continue to occur, check to see that the serial and parallel are set up correctly. If not, replace the serial and/or parallel boards.

### Game Controller

The game controller will report back with an error message of 13xx. Run the diagnostic software and check the joystick for operation. If the test will not run properly, try a different joystick, or move the joystick to the other connector and try the test again. If the test continues to appear, and the joystick is known to be good, replace the game card or check the configuration.

### Hard Disk

The hard disk error code that will be received upon start up will be in the 17xx range. Most often this will occur if the CMOS memory setting has lost the drive setting. Run the setup and check to see if the drive is still selected as being present, or correctly selected. If not, correct the situation. Refer to your drive type to match the selection from the drive menu listing.

Run the diagnostic routine and check the service of the drive. If the disk has in some way lost communication with the controller card and the system board, it will need to be reformatted. If the drive does not seem to start, check the power connections.

If a code of 1703, 1705 to 1709, 1711 to 1713 was returned, check the cables for continuity and replace the bad cable. If correct, the drive may need to be reformatted or replaced, especially if the error occurs after reformatting the drive.



## 9/PR Printer

---

### 9/PR - A An Introduction

---

Printers can be a wide variety of types. There are:

- dot-matrix printers
- laser printers
- ink jet printers
- laser jet printers
- bubble jet printers and several others

#### Dot Matrix Printers

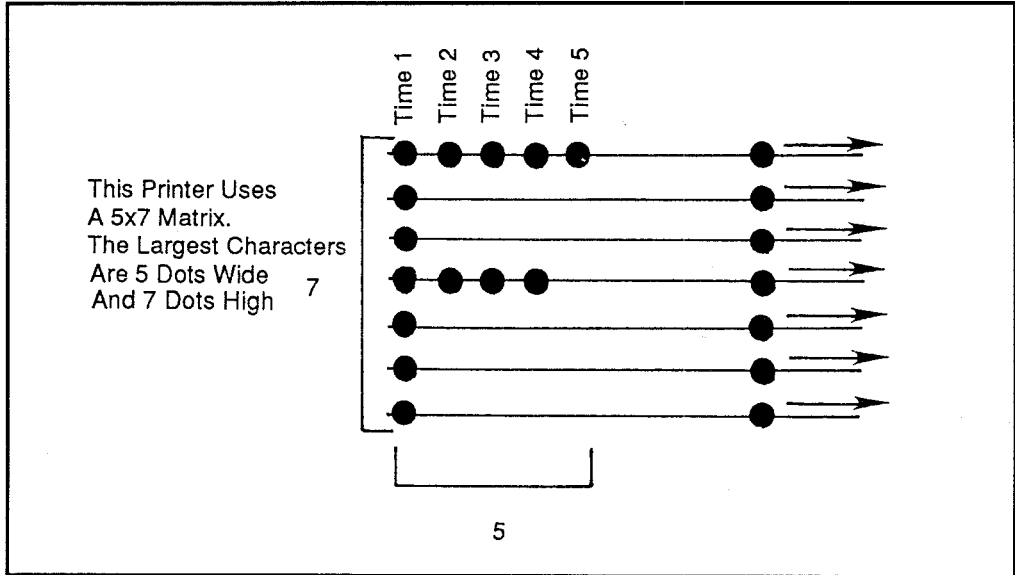
A dot-matrix printer creates characters from a print-head that consists of one or two vertical sets of print-wire mechanisms. Vertical lines of dots are printed as the print-head moves across the page. As a general rule, lower quality printers use 9 pins and higher quality printers use 24 pins. However, there are times when a good 9 pin printer can outdo a bad 24 pin printer.

A 9 pin printer can strike the paper on 9 separate lines in one column at the same time. This may be enough dots to make up a portion of a single character that is less than 9 dots high.

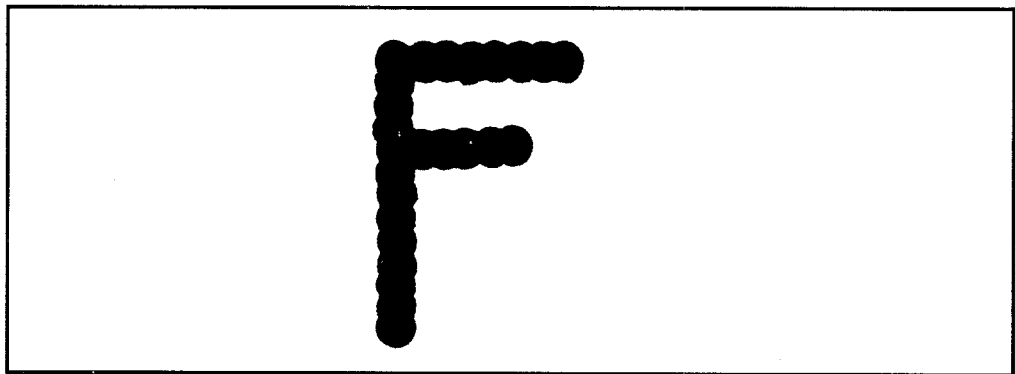
The second column would create the second portion of the character and so on to the width of the character, which may be 5 columns wide. This could be a character that is 5 columns wide by 7 rows tall or 5x7 matrix printing. Figure 1 illustrates this function.

Some printers have what is called “near letter quality” (NLQ) which makes multiple passes over the same character and fills in the gaps between the dots printed on the first pass. The results give a character that is similar to a continuously drawn character as in Figure 2.

Each wire of a print head is driven by some kind of solenoid and return spring. The solenoid is activated and the wire is sent out to strike the paper. The smaller the wire, the smaller the dot printed and the higher the resolution capable for the printer.



**Figure 1:** Printing dot-matrix characters



**Figure 2:** NLQ type of character

When damaged, print heads should be replaced as a whole. Most printers allow an easy removal and replacement of the print head.

These print heads can become gummed with ink and dust and require cleaning. The careful use of a denatured alcohol is often a good way to dissolve the residue on the print head wires.

**Daisy Wheel**

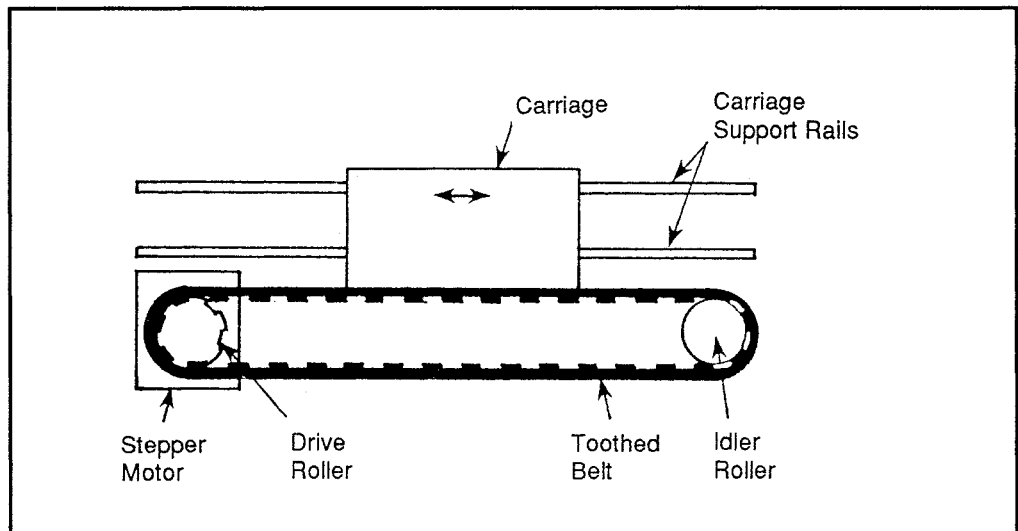
The “Daisy-wheel” is a printer that prints like a typewriter. Each letter is made on a separate petal of a wheel that is struck by a hammer. The letter then strikes a ribbon and prints a letter.

The wheel rotates to the letter desired and is then struck by a single solenoid driven hammer. On some printers, this hammer has a notch that mates with the back of the letter on the print wheel to insure that the letter does not slip from the hammer.

The wheel is turned by a stepper motor. The letters are rotated in precise steps and stopped in front of the hammer for striking. The wheel does not spin back to a home position before printing the next character, rather the printer remembers the position and advances to the next location, either by spinning the wheel clockwise or counter-clockwise.

### Carriage Drive

The print-head is moved across the carriage by a toothed belt as shown in Figure 3. These belts are connected to a series of gears that are turned by a drive motor. This belt can be damaged from a printer head that jams, or if the print head is moved by hand while the printer is on. If the teeth are removed from the belt, the printer will skip when printing. Replace worn or loose toothed belts.

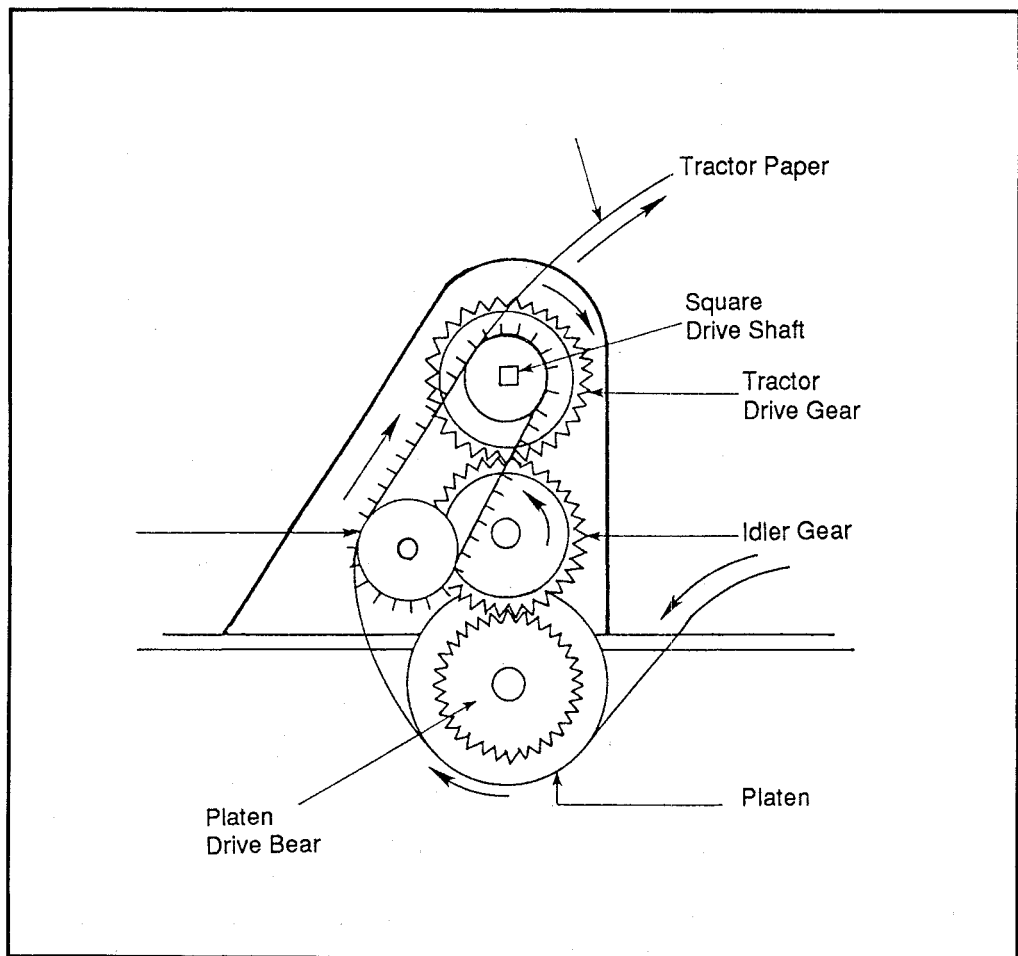


**Figure 3:** Carriage drive belt system

The print head rests on support rails that are lubricated to allow easy movement. Usually one of the two rails will be mounted off center so that the print head can be moved closer or farther away from the paper.

On other printers, the print head carriage may be pulled by a cable and stepper motor. If this cable becomes loose, the carriage may slip and not print evenly across a page.

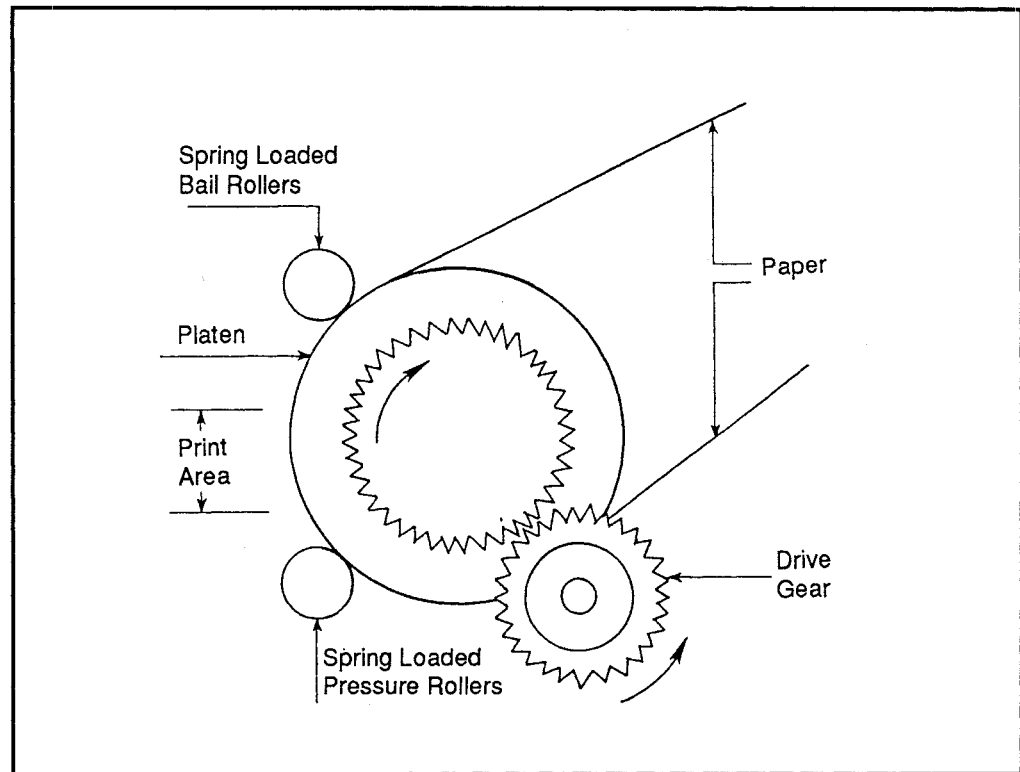
The stepper motor is told to step in increments (some as small as 1/120 of an inch) to place the print head along the platen. When the printer is first turned on, or must return to the home position, a carriage stop sensor tells the stepper motor to stop.



**Figure 4:** Tractor feed mechanism

### Paper Feed Mechanisms

Figure 4 shows the print mechanism for a tractor feed printer. The tractor is turned by a series of gears. On the tractor assembly is a gear with pins that pull the paper, or push it, past the print head. Some printers employ a flexible gear with pins to pull the paper. These pins fit the extra edge of paper made for tractor feed. Some printers allow the removal of the tractors (or disabling) to accommodate friction feed.



**Figure 5:** Friction feed mechanism

A friction feed printer has a platen and roller assembly designed to give a certain amount of friction to a piece of paper to push it past the print head. This allows for inserting single sheets of paper.

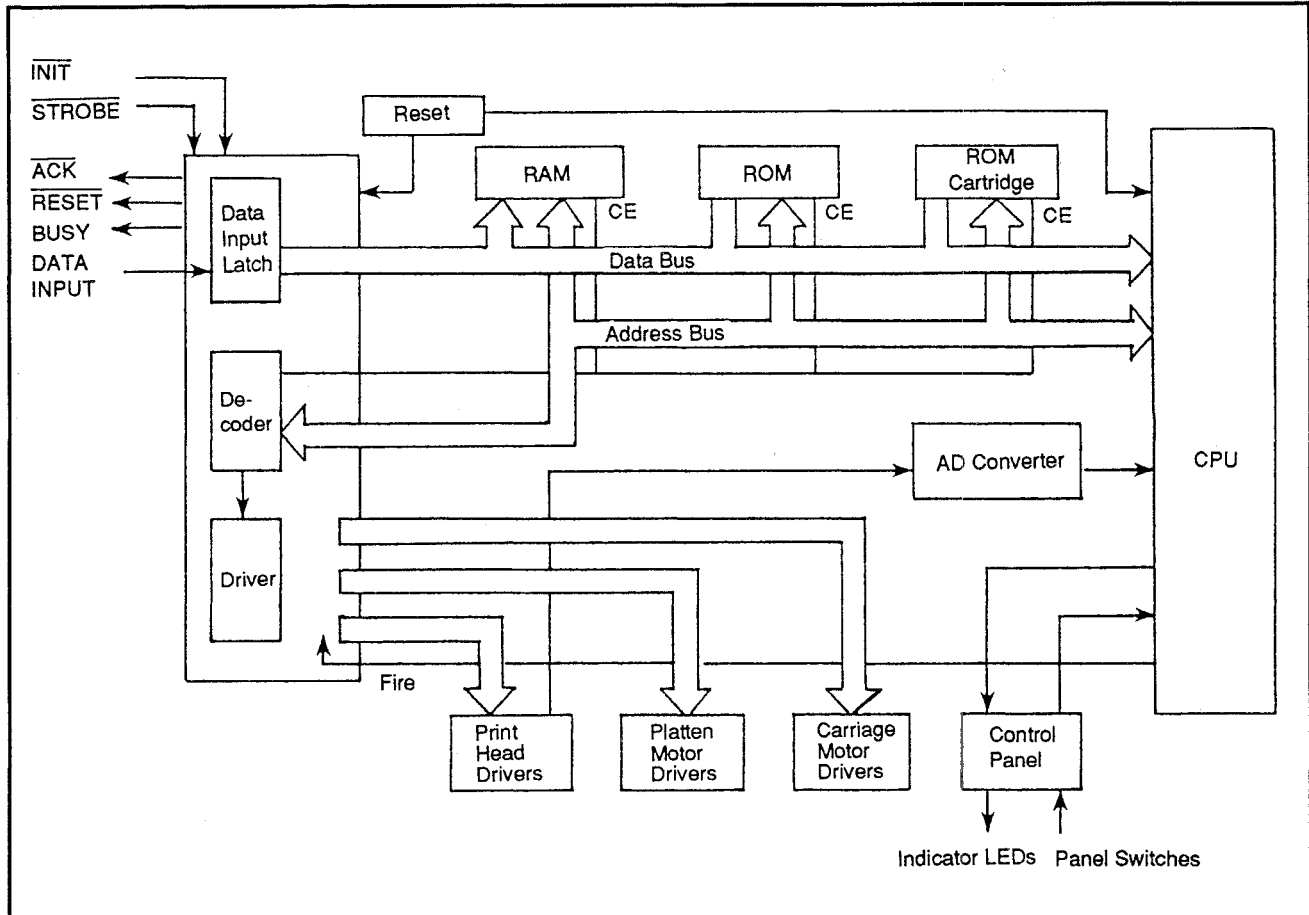
A stepper motor receives signals from the printer CPU that tells the motor to step to the next line. This drives the platen drive gear and tractor feeds (if present).

### Printer Control Section

The control section of a printer is operated by a small CPU IC. The printer CPU uses an address bus to address the inputs, memories and outputs of the system.

Data goes from one part of the printer to another by means of a data bus. Figure 6 shows a block diagram of a printer's control circuits.

A set of ROMs contains the necessary instructions to control the printer CPU. These ROMs may also define a pattern of every character used for typing by the printer. When the code for a particular letter is received, the print looks up the code and knows how to reassemble the letter. Usually, the CPU of a printer will be 8 bit.



**Figure 6:** Block diagram of a printer's control circuits

Many of the newer printers will have as few as two ICs, with every operation the printer does handled by these two. This is highly efficient, but makes repair work difficult or impossible if you cannot get replacement chips.

On the other hand, if replacement parts are available, troubleshooting such a printer is simple. If the problem does not occur in the two main ICs, it will be found in one of the discrete components or in one of the ROM chips, RAM chips or various other sections.

Problems that are found on the one or two PC boards in the printer are most easily fixed by board swapping. This is the method that the printer manufacturers suggest, especially if one of their proprietary chips malfunctions. If the problem is a discrete component, tracing and fixing the part may be possible.

# 9/PR

## Printer

9/PR - M

Maintenance

## 9/PR

### Printer

### 9/PR - M

#### Maintenance

Printers become dirty over time and need periodic cleaning and maintenance. The printer should always be stored covered when not in use to avoid a build-up of dust in the mechanisms.

For periodic cleaning and maintenance (once or twice a year) the printer should be completely cleaned. Unplug the printer and remove the case. Blow (with a clean air source) any dust or paper fragments that may have collected in the casing or on the printer parts.

#### **Pulleys/Gears**

Inspect all the pulleys, gears and belts for signs of wear. Replace any partially stripped gears and pulleys.

#### **Print Head**

The print head mechanism should be cleaned with denatured alcohol (or some other suitable cleaner) and cotton swabs to remove any grime that has built up. Work carefully and slowly so as to not bend the wires or get cotton caught in the print wires. Do not get the cleaner on any of the rubber parts as this can cause them to break down and become brittle.

#### **Platen**

Clean the platen (with platen cleaner, not alcohol). The purpose is to remove any ink that may have become embedded in the platen. This is best done with the platen removed. If the platen cannot be removed, clean it by rotating while wiping with a soft cloth dampened with the cleaning fluid. (NOTE: Never turn parts of the printer while it is on. There will be a resistance factor that will strip gears making the printer skip in some fashion or causing other damage.)

#### **Lubrication**

The next step is to lubricate those parts that require it. Printer manufacturers will usually specify their choice of lubrication. Use only their recommendation or a certified substitute. The grease and oils must be viscous enough to do the job, but not migrate to areas where lubricants are not wanted (or cannot be tolerated). If all else fails and you cannot find manufacturer recommended products, off-the-shelf products can be used if you spend the time to compare the specifications.

**9/PR**  
Printer

---

9/PR - M

---

Maintenance

---

---

The service manual will indicate the areas requiring grease and oil. These will include the platen drive gears, the platen bearings, pulleys, and rollers.

Grease will be used to lubricate the large mechanisms that handle power. Grease all gear teeth (not the paper pins), and mechanisms that slide or rotate against a cam.

Oil is used for mechanisms with smaller spaces between parts and for parts that move only a short distance. Oil should be used for bearings and bushings that carry rotating shafts.

**Motors**

Motors will most often be permanently sealed and cannot be lubricated. Those motors that can be lubricated (relatively rare) will probably have a felt wick for the oil. This wick will provide oil over a long period of time. If present, the wicks will most often be hidden under shielding, with the only way to get oil to them being to apply oil to the rod that holds the wick.

Print head wires, solenoids, and armatures should not be lubricated on dot matrix printers. These operate too fast to benefit and will often gum up from lubrication. Many good ribbons have lubricants built in and apply some when they come in contact with the moving parts.

The final check is to run a self test on the printer and see if everything prints. For most printers the self test is initiated by holding down the line feed key (or one of the others) when turning the unit on. The printer will then print continuous rows of characters sets set up in the test protocol.



---

## 9/PR - TR

### Troubleshooting and Repair

---

## 9/PR - TR - LP

### Laser Printers

---

#### Introduction

Laser printers work in a way very similar to copiers. The major difference is that a copier takes an original and makes a copy of it, whereas a laser printer takes information sent digitally to it from a computer and creates an image. This difference is in the front end. The copier uses light to scan the original—the laser printer has a data port. The rest (drum, cartridge(s), etc.) is almost the same. Most of the repair and cleaning procedures for copiers apply to the laser printer. See Section "11/C Copiers".

Many of the important operational parts of the laser printer are mounted in a single removable cartridge. This means that most laser printers require the drum and toner to be replaced at the same time (and you have no choice since both are in the same cartridge). Some, however, allow toner replacement. This is because the drum can last to make about three times as many copies as a single toner charge.

#### General Operation

Within a laser printer is a drum to which a dark toner powder is transferred by the developing roll. The toner image is pressed to the paper and then fused to the paper by hot fusing rollers. The photosensitive drum is turned several times per page to complete an image. Sections of the image (say 1/3 each) are transferred from the drum to the paper with each revolution.

As the drum rotates, it does several things. First, the drum picks up toner. Another part of the drum places the toner on the paper. A third section has the residue toner removed and discarded so the process can start again.

The drum is photosensitive. It has a light-sensitive layer of organic-photoconductive material on its surface. Therefore, by its nature the surface of the drum is very sensitive to light and should not be exposed to direct sunlight or even to room lights for long periods of time. If so exposed, the ability of the drum to hold an image and transfer it to paper may be degraded.

The inner part of the drum is made from an aluminum sheeting. This aluminum

tube is electrically grounded. As the drum is turned, it is exposed to light and becomes conductive. If the outside of the drum at that point is charged, and the drum is struck by a bright light, the charge on the drum will be drained off to ground.

At the start of a printing process the surface of the drum is charged with a uniform negative charge. This charge may be about -600 V. This “conditions” the drum.

A long narrow wire, called the primary corona wire, is mounted in a long enclosure. This wire is given a charge of as much as -6000 V. This voltage causes the air molecules around the wire to break down and become ionized. The air around the wire is no longer an insulator and is able to transfer charged particles (ions) to the drum. As the drum moves under this corona wire, ions from the corona transfer to the surface of the drum which is what gives the drum its uniform charge of -600 V.

To create an image on the drum to transfer to paper, the printer turns on a small laser diode. The beam from this diode is reflected by a series of mirrors and aimed onto the surface of the print drum. As the beam reaches the photosensitive material on the drum, the material becomes conductive. The negative charge of the -600 V is reduced to a charge of about -100 V. Each dot of the image to be created on the drum is made of tiny -100 V charges.

As the drum continues to turn with the new charges attached, they pass the toner section. The toner is a black plastic powder that has small particles of iron within. The iron particles can be attracted by magnets and can then be carried along. A fixed magnet is mounted inside the developing cylinder which attracts the toner powder. A blade levels off the toner so the surface of the developing cylinder carries a uniform layer of toner. The developing cylinder has a negative charge and the toner particles take on this negative charge. As the amount of charge is varied, the amount of toner picked up is varied and changes the density of the print.

Then the drum turns and comes in contact with the paper. Beneath the paper is a second corona wire which generates a positive charge. The positive charge is strong enough to attract the negatively charged toner dots off the drum and onto the paper.

At this point the toner dots are sitting loosely on the paper, being held there by the electrostatic charge only. A negative charge is created by the static charge eliminator which weakens the attractive force between the paper and the drum and allows the paper to be pulled away easily.

To make the image permanent, the toner dots are joined to the paper by fusing. The fusing section consists of two rollers with the upper roller containing a very hot lamp. As the paper passes through the fuser section, the heat from the lamp melts the plastic material in the toner, and presses the toner into the fibers of the paper.

Fusing occurs at about 180°F. When there is no paper present, the fusing elements rest at about 165°F. A feedback circuit adjusts the circuit's fusing temperature to keep it at a constant. A protective switch called a thermoprotector keeps the fusing rollers from overheating. If the rollers reach 210°F, the thermoprotector switch will open and cut off all power to the lamp. These fuser rollers are Teflon-coated so toner will not stick to them.

A cleaning pad clears any excess toner or dust from the rollers as they rotate. It also applies a thin coating of silicone oil which helps to keep toner from sticking to the roller.

The drum continues to turn and must be cleaned for the new information to be transferred to it. A rubber cleaning blade scrapes off any remaining toner which then drops to the bottom of a cartridge. A sweeper blade rotates and brushes away any toner that has accumulated in the cartridge. This excess toner is then passed to a discard bottle.

The drum continues to rotate and then passes under erase lamps. These lamps drop the charge on the whole surface of the drum to a uniform -100 V. The drum is now conditioned and ready to start the entire process over again.

### Laser Diode

The job of the laser diode is to create an image across the entire width of the drum. Some laser printers may employ several laser diodes with each working a section of the drum.

The laser diode creates a beam of laser light which is then focused by a series of lenses. The beam is aimed at a rotating six-sided mirror. As the mirror turns, it causes the beam to sweep across the surface of the photosensitive drum. As the beam moves across the drum, the laser is switched on and off by a beam detect sensor. When the beam hits a point where the drum should have a dot, the laser is energized. If the drum should have a blank spot, the laser is turned off.

It should be noted at this point that the resolution of laser printers is rated in dots per inch (dpi). Most laser printers today are rated at 300 dpi, which means that they are capable of focusing the laser to create as many as 300 dots for each inch on the drum, which means that each dot is approximately 1/300th of an inch. As

with a computer monitor, the dots are often referred to as pixels. Many make the mistake of thinking that the laser printer creates a continuous image, which it does not. You can see the pixels with a magnifying glass, and sometimes with your eyes alone. You can expect to see resolution improve as technology improves.

Once a single pass has been made, the drum steps (or turns) to the next line and begins the process over again. Each side of the rotating mirror works on a single line across the drum. This continues until the image is complete, at which point it is printed.

### Control Circuits

The control circuits of a laser printer are themselves a mini, slave computer. Information from the PC is sent to the printer's CPU which then must convert that information into a memory-stored representation of the image to be produced. Each storage unit (or dot representation) is held in a matrix configuration memory. This is then transferred to the drum surface by the scanning laser diode. The information received may be individual codes representing letters or actually dots to create a picture. The more information for a page, the more printer memory required to generate a complete image, and the longer it will take to print that page.

Many laser printers are shipped with the minimum of 512 K of memory. This is sufficient for printing a full page of text along with some minor graphics. A full page of graphics, or complicated graphics (a picture) may require a laser printer with 2 megabytes or more of memory, depending upon the complexity of the drawing.

To give you an idea of why so much memory is needed, think again about what the 300 dpi rating means. With 300 dots per inch, each square inch of the drum (and on the paper) can contain up to 90,000 dots (300 x 300). Now imagine a standard 8.5x11 sheet of paper, with a 1/2 margin all around. This means that the surface area will be 75 square inches. The total number of dots possible, then, is 6,750,000. Each of those dots must be represented in memory.

### Possible Service Problems

Laser printers include many electromechanical parts. When they work, they are great, but if problems occur, it will usually be time to call in the service repair person. Specific service information is virtually always proprietary and manufacturers won't release it except to their own technicians. Much the same is true for replacement parts. Until this policy changes (unlikely), only the most basic repairs can be accomplished.

### Paper Jams

Paper jams occur most frequently and are handled in the same fashion described in the copier section. The travel path will be slightly different. It will also be shorter and generally less complicated than in a copier. This makes it easier to clear paper jams.

If paper jams occur often, the cause could be as simple as poor quality paper, improperly stored paper, or a printer that needs a thorough cleaning. Also examine the rollers and other feed mechanisms.

With some laser printers, if the paper tray (and the paper in it) isn't exactly flush with the entrance to the paper path, the paper will enter at an angle and cause a jam. Although this isn't a common problem it is worth consideration.

### Toner

Toners are the only chemical required in the laser printer system. With most laser printers, the toner is inside the drum cartridge, which makes proper storage even more important. Whether integral or separate, the toner chemical/cartridge is highly sensitive to improper storage. It must be kept in a cool, dark (or at least dim) and dry place.

Even with the best storage conditions, toner has a definite shelf-life. This is usually 2-3 years, but the shelf-life decreases dramatically if storage conditions are poor. Under certain circumstances the shelf-life could be 6 months or even less. Old toner shouldn't be trusted. It can cause a variety of problems — from poor print quality to gumming up the printer.

If there is a problem with the image quality, suspect first that the toner is bad. (Even a brand new cartridge may be bad. Even if your own storage practices are perfect, you have no control over the storage practices of the person or company who sold it to you.)

When replacing toners/cartridges, do as recommended both by the owner's manual for the printer and by the toner manufacturer. Replace all the parts recommended at the toner change time.

### Drums

As above, the drums are light sensitive. For this reason they are put in light-free packaging. The replacement cartridge must be kept in this packaging until needed. Drums can be damaged by strong light. You don't need total dark when replacing the drum cartridge, but try to minimize both the quantity of light and the intensity of light that falls on the drum.

### Smearing

Smearing and printing problems that occur will either be software based, or similar in fashion to those described in the copier section. The major

**9/PR**  
 Printer

9/PR - TR	Troubleshooting and Repair
9/PR - TR - LP	Laser Printers

difference is that the drums in laser printers fail more often than those in a copier due to the organic material present.

**Test Page**

Most laser printers can be made to print some form of test page. If the test page is being printed properly, but the pages being sent from the computer are not, the problem is not in the printer. It will be found in the connection between the printer and the computer, or in the software.

**Some Additional Safety Factors**

The laser printer should not be operated with the cover open. Fortunately, this is impossible unless a safety switch has been over-ridden in some manner or has become nonfunctional.

There are several reasons for this design. As just discussed, light falling on the drum should be minimal. It should never fall on the drum while printing is being done.

**Warning!**

*There are high voltages present when the laser printer is operating — as high as 6000 V. This is extremely dangerous. Also, the laser diode in the printer produces laser light and is invisible to the naked eye. When the unit is operating under normal circumstances (closed) the laser emission is safe. But if the case is open and somehow made to operate, the laser light could be present and cause some eye damage. Avoid even trying to look through paper slots to see into the printer when it is operating. The laser light may be shielded from being seen in this manner, but don't take the chance that it is. Damage to the retina of the eye from a laser beam can be instantaneous, and is usually permanent.*

# Section 10

# Home Appliances

---

## Table of Contents

<b>10/A</b>	<i>An Introduction</i>
<b>10/A - BPS</b>	<i>Basic Power Supplies</i>
<b>10/A - W</b>	<i>Wiring in the Home</i>
<b>10/TR</b>	<i>Troubleshooting and Repair</i>
<b>10/TR - A</b>	<i>An Introduction</i>
<b>10/TR - A/C-R</b>	<i>Air Conditioners, Refrigerators</i>
<b>10/TR - A/C-R - A</b>	<i>An Introduction</i>
<b>10/TR - A/C-R - EP</b>	<i>Electrical Problems</i>
<b>10/TR - A/C-R - MP</b>	<i>Mechanical Problems</i>
<b>10/TR - C</b>	<i>Controls</i>
<b>10/TR - ECM</b>	<i>Electronically Controlled Motors</i>
<b>10/TR - T</b>	<i>Transformers</i>
<b>10/TR - Th</b>	<i>Thermostats</i>

Table of Contents

---

---

---

---



# 10/A

An Introduction

10/A - BPS

Basic Power Sources

## 10/A

### An Introduction

## 10/A - BPS

### Basic Power Sources

The most basic power used in the home to power devices is the AC current supplied to the home. The power is delivered to the home via some kind of circuit breaker box, or for older homes a fuse box.

#### Maximum Current

A typical maximum current available in the circuit breaker boxes may be 100, 125, 150, 200 and 400 A service to the home. There is a main circuitbreaker (rated at full service box load), with sub-breakers for the various sections of the home. Each sub-section might be broken down to 15 or 20 A breakers for sections of the home's normal wall sockets with a 50 or 60 A breaker for the stove or range and a 50 A breaker for the AC/heating unit.

Homes of the past had electric loads much less than those used today. A 60 A service, using just two wires (one hot and one neutral) and delivering 120 V was fairly standard. Today such a home is "antiquated," and 100 A service is considered to be minimum.

#### Three-Wire System

Connection to the outside world for most homes is now done through a three-wire system. This system consists of two hot lines and one neutral. They deliver 120 V between each hot wire and the neutral, and 240 V between the two hot wires. This is a standard 120/240 V service.

#### Volts Rating

Systems are rated at 120 V, but more typically deliver supplies that vary from 115 to 125 V throughout the day, due to normal daily fluctuations in the utility's supply lines because of varying loads, daily switching procedures, and other activities in remote parts of the utility system. Each line referenced here will be called out as 120 volts for each hot wire to ground and 240 V for measuring between two hot wires. Bear in mind that these are nominal values.

#### Overhead Three-Wire System

The typical overhead three-wire service from a utility consists of two insulated wires twisted over a bare stranded wire and is known as a "triplex". Aluminum conductors are most often supplied, but copper conductors may be used when the house is located near salt water areas.

**10/A**  
An Introduction

This type of system will be connected at the customer's end above or below the roof line depending on the height requirements set by local codes. The three utility wires will connect to the three service entrance wires at a "drop loop." This drop loop is done to keep water from getting inside the house wiring mast that houses the wires running to the meter and circuit breaker box. There are minimum clearances that must be met for proper placement of this wiring.

An underground electrical system may be used in some areas. Usually, this system of wiring will be found in newer home areas, or older areas converted for beautification. In this case the utility line will be buried up to the point where the breaker box and meter are located on the home.

The mains (the two hot wires and neutral wire) are fed into the box. The hot wires are fed through a double-pole double-throw circuit breaker and then connected to separate bus bars. The neutral line is fed to a third bus bar, is active at all times, and will be connected to ground.

**10/A**  
An Introduction

10/A - W

Wiring in the Home

**10/A**  
An Introduction

**10/A - W**  
Wiring in the Home

**National Electric Code**

The National Electric Code (NEC) designates what type of wire, connections and connectors can be used for power lines in the home. Each circuit within a home is known as a branch. There can be two or more outlet branch circuits in five ratings allowed in residential wiring. Those circuits handling 50 A circuits or more can be used but can only serve one outlet each. These high amperage circuits may be in air conditioning and heating systems.

**Circuit Amperage**

The amperage of a circuit is determined by the circuit breaker or fuse protecting the circuit. The breaker or fuse rating will be (usually) determined by the wiring size, which in turn is determined by how the outlet(s) will be used and the expected current draw.

**Wire Rating**

Circuit Rating in Amps	Copper Wire Size (AWG)
15	14
20	12
30	10
40	8
50	6

**Number of Outlets**

The NEC has no limitation upon the number of outlets that can be connected on a single branch circuit (although local building codes might). If there is a sufficient number of circuit branches provided, there will be no need for overloading any one circuit.

**Electrical Load**

The load on these branches should balance across each of the main bus supplies found in the circuit breaker box. If the loads are unbalanced, tripping of the breakers can occur.

In other words, if there are six branches, the draw on them should be more or less equal. The home should not have a condition in which 3 of the branches are used heavily and the other 3 not at all.

Building codes generally require that the home has an outlet for every 10 or 15 running feet of wall, and at least one outlet in every room. Good building practice (and sometimes by local building code) will never have all the lights and outlets in one room connected to the same breaker. Instead, the ceiling light in the room will probably be on a completely different circuit. You may even find that the outlets in the same room are on different branch circuits. This practice not only helps to balance the load, it helps to ensure that if one circuit has a problem, there will still be some power available in a given spot.

The caution in this case is that when you flip the breaker and kill a particular outlet, do not assume that all other outlets in that area are likewise killed.

### 15 A and 20 A Branches

A 15 A branch circuit is used for ordinary lighting and general-use receptacle outlets. A 15 A circuit breaker or fuse is used to protect the No. 14 wire used in these types of circuits. Only 15 A rated receptacles can be attached to them. Any type socket for lighting load may be connected to the receptacle, but must be at a maximum load of 12 A, or 1440 W. If the circuit feeds lighting outlets or small appliances are used on this type of circuit, the total load of the fixed appliances must not exceed  $7\frac{1}{2}$  A or 900 W.

The NEC requires that two 20 A branch circuits be provided for all small appliance loads including refrigeration equipment that may be used in the kitchen, pantry, etc. No lighting outlets may be connected to them except for possibly a clock hanger-type outlet, or an outdoor receptacle. Both of these type of circuits must run to the kitchen so that some of the receptacles in the kitchen will be connected to them and may be found in other rooms as well.

### Tip

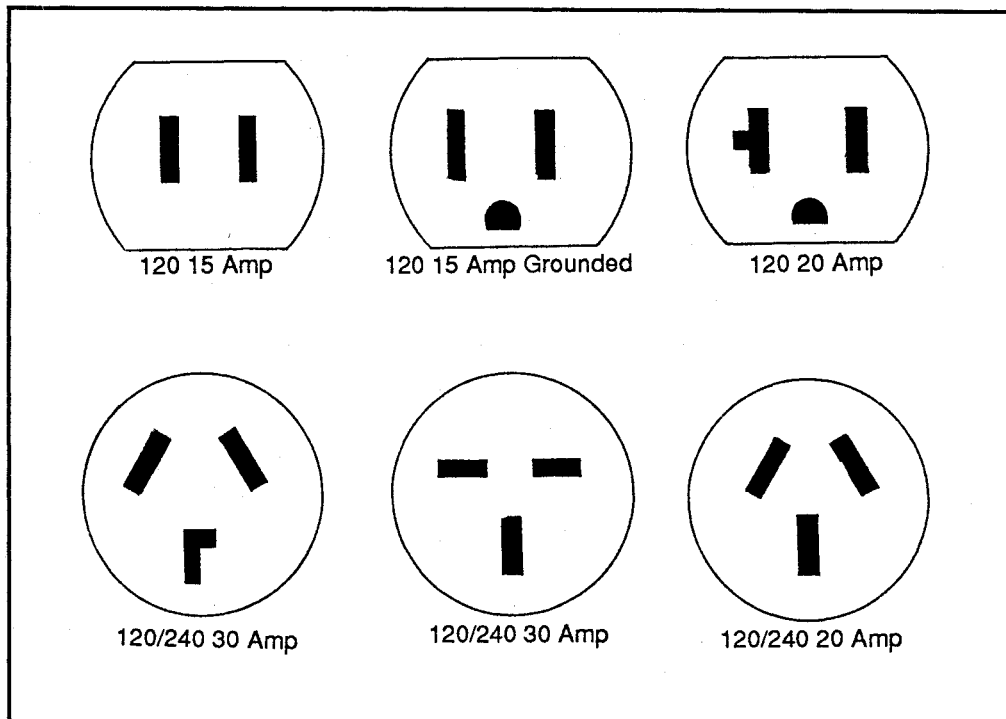
Although many people fail to do so, or cannot do so, it is best to have major kitchen appliances, including the microwave oven, on dedicated branch circuits.

The 20 A circuit must also be provided for the laundry area where it may supply one or more receptacle outlets. If a 20 A circuit is provided, receptacles of either 15 or 20 A ratings may be provided. Plugs that fit 20 A receptacles will not fit into 15 A receptacles, but 15 A receptacles can fit in 20 A receptacles.

The various type of outlets that you may find connected to the appliance you are to be working on is shown in Figure 1. These devices should always be removed from the receptacle when servicing.

### Receptacles

The NEC also requires that one receptacle in any counter space wider than 12" be provided. These receptacles are best placed staggered from one circuit to another to prevent overloading. Spaces that are separated by refrigerators, sinks, and range tops are regarded as separate spaces.



**Figure 1:** Receptacle types

### Larger Amp Branch Circuits

Larger ampere branched circuits (30, 40 and 50A) are not allowed in dwellings to supply lighting outlets. They are to be used for ranges, clothes dryers, or other such similar appliances. There is rarely more than one outlet in use that supplies this kind of current.

### Wiring Used

The only wiring that is acceptable to be used is that wiring that has been UL stamped. Any properly sized UL wiring will be acceptable for use by the NEC. Local wiring codes may vary and should be checked before changing or adding wiring.

Each individual wire consists of a single conductor that is either sheathed or bare, solid or stranded. All wire has resistance that limits the flow of current and causes the voltage applied to the current to drop off as the current flows along the wire. The wire size must be selected so that the voltage drop is not too excessive to operate the circuit in which it is applied for a specific load.

Wire used in homes is most often copper, but some areas may still use aluminum and copper clad wiring. The latter are being phased out for two reasons. Aluminum and copper clad wiring are not as efficient conductors as copper and

will usually need to be larger to handle the same load requirements. Worse is that aluminum has a greater tendency to oxidize, and when this happens the connection may become loose, and could even begin to arc. If this happens, not only may electrical service be disrupted, but there is a greatly increased chance of fire.

The NEC defines a cable as more than one conductor in an overall insulated wrapping. Wires in a cable are shielded from one another by an insulating material (dielectric) which is a material that does not conduct current. The most common type used is made from thermoplastic materials and is generally color coded similar to the standards established.

As current flows through a wire, heat is generated and this heat varies as the square of the current. The heat poses a stress on any wire insulation. There is a limit to the amount of heat each type of insulation can withstand. Bare wire can also overheat and anneal. This changes its properties and causes some failure to occur when overheated too much. The NEC has created a list that shows the maximum current-carrying capacity in amperes (called ampacity) that is safe for different wire sizes and different insulation types used under varying installation situations. Refer to an NEC wiring code book for more information on this topic.

### Wire Sizing

Wire has a diameter-area relationship used to make measurement standards. The units of measurement are in mils and circular mils. A mil is 1/1000 of an inch and a circular mil is the area of a circle that has a diameter of 1 mil. Since the area of a circle is always proportional to the square of its diameter we can use the following as an example:

Diameter in Mils	Area in Circular Mils (cm)
1	1
2	4
4	16
16	256
50	2,500
500	250,000

The measurement is taken at the cross-section of the conductor wire only and not the casing which holds the wire. It is obtained by multiplying the diameter in inches or mils to get the area in square inches or circular mils (cm).

Wire sizes are designated by numbers for the common sizes of electrical wires in use rather than referring to areas or diameters. The gauge most often used is

the American Wire Gauge (AWG) which is also the same as the Browne and Sharpe Company gauge. Gauges for measuring wires in this manner are available at most hardware specific stores that carry electrical supplies.

The larger the wire, the smaller the gauge number. A number 14 wire is the smallest wire that can be used on branch circuits and has a diameter of 64 mils. Smaller wires (16 or 18 gauge) wire can be used for electric cords. Gauges 20 to 50 are for manufactured electrical products and for use in other nonhouse wiring schemes.



**Figure 2:** Cross sections of copper wire

Figure 2 shows some actual sizes of wiring that can be found in a dwelling. Wiring numbers for homes will usually start at 18 and increase in size to 1, then 1/0, with 2/0 (which would be 2 naught wire) as the largest home wiring.

18 and 16 wiring sizes can be found in such items as door bells, thermostats, flexible cords and other small appliances. Wiring for 120 and 240 V lighting and receptacle circuits will typically be 14, 12 and 10 AWG wiring. Wiring beginning at 8 and larger will be used for service entrance cables, feeder cables, ground or 240 V appliances. Most wiring will have printed on the casing the size and type of wiring it is and will be found continuously marked.

### Stranded Wire

The most common wire to be found in a home will be the 14, 12 and 10 AWG solid wire. These sizes are easily shaped and handled without being too stiff to cause problems in routing them. 8 gauge wire and larger must be a stranded wire for practical reasons. The stranding for these wires is standardized for each size with the number of strands and the size of each strand specified in the NEC.

### Color Coding of Wire

Building wire will be found in standardized colors to identify their purpose once they are installed. A common misconception is that white or gray wire is used only for ground. This is not necessarily true. For example, when a white and a black wire are used in a switch loop, white may be used as the hot wire going from

the source to the switch. Another exception is when a two-wire cable of white and black wires is used to supply a single outlet for a 240 V appliance. If white is used in this manner, it must be painted black to identify it as a non-neutral conductor.

Do not take any chances. If you assume every wire to be hot, you're less likely to run into trouble. The most commonly found wire colors are:

No. of Circuit Wires	Color of Wire Insulation
2	White, Black
3	White, Black and Red
4	White, Black, Red and Blue
5	White, Black, Red, Blue and Yellow

In cables and cords the same color scheme will be used. If an additional insulated conductor is provided for bonding, it must be green. A bare wire may also be included for bonding. Bonding wires may also be considered the grounding wires.

Terminal colors are also used to identify the type of connections to be made. They are listed below:

Terminal Color	Wire Type to Connect
Silver	"Grounded" Wires
Green	Bonding or "Grounding" Wires
Copper or Brass	Hot Wires
Oxidized Finish	"Common" Wire (3-way switch)

### Low Voltage Wiring

Many electronic items in the home will be connected to the house wiring and require very little power. These devices (like door bells and chimes, loudspeakers, intercom wiring, heating and cooling relays, some types of outdoor lighting) may use smaller nonstandardized wiring. These devices will typically use less than 24 V and pose little or no safety hazard.

The power for operating the low-voltage circuits comes from smaller transformers rated at no more than 100 W. Small transformers supply the low-voltage for circuits that operate indoor signal or control circuits. These may be mounted directly to an outlet box cover or to a joist or stud near an outlet. The primary



**10/A**  
An Introduction

winding for the transformer is rated at 120 V and is connected to an outlet or hard-wired. The secondary winding is usually a fixed rating from 8 to 24 V with some having taps that permit voltage choice such as 8, 12, 16 or 24 V depending on the need. These transformers are designed so that if the secondary windings are shorted, the capacity rating of the transformer will not be exceeded. This limits the current output and reduces any chance of secondary fire. The low-voltage also eliminates the shock hazard. These devices are UL listed transformers and rated in watts and/or volt-amperes (VA). The most typical will be 5 to 10 VA, with a few rated at 100 VA.

Low voltage wires should never be run in the same conduit or cable with wires carrying full voltage. They must never be installed in an outlet box or switch box that has full voltage wires unless a metal barrier of the same thickness as the box walls separates the two wiring types.

**10/A**  
An Introduction

---

10/A - W

---

Wiring in the Home

---

---

## **10/TR** **Troubleshooting and Repair**

---

### **10/TR - A** **An Introduction**

---

The exact procedure for troubleshooting will vary depending on the appliance being examined, but in general will follow the same basic pattern. That is, you will begin with the most broad, the most obvious, and the easiest. Is the device getting power? Is it being operated correctly? Has it ever worked? Has it ever been made to perform that particular function before?

#### **Current Draw**

Many computers draw just slightly more current than a light bulb — an electric dryer can draw as much current as all the rest of the house combined. Even a coffee maker can draw appreciable current (when compared to many other electronic devices). This means that if a fuse or breaker outside the device is being blown, the problem isn't necessarily in the device itself. It could be that you have simply overloaded the branch circuit supply power. While this isn't likely when dealing with lower-draw items, it's a distinct possibility when considering appliance failures. How far "up the list" you place it depends on the appliance itself and the amount of current it draws.

Keep in mind that this factor applies to more than just those appliances which provide heat. Another major source of current draw is a motor, especially when it is starting. Items which use large motors are particularly prone to popping breakers when the circuit is at or near overload.

In short, what may seem to be a major problem may be cured by simply unplugging a few things, or not using them all at the same time.

#### **More Complex Appliances**

As devices become more and more versatile they also become more difficult to operate. All the buttons, knobs and controls may function perfectly, but if the person operating them is doing so incorrectly, the function of the device won't be what it should. It may not operate at all.

Making matters worse in this, owner's manuals are notorious for being poorly written. A classic (and unfortunately true) story is of an instruction manual in which Step 7 warned the person to complete this step before trying Step 3.

**10/TR**  
Troubleshooting

This problem is particularly troublesome to someone who has never used that kind of device before, or even someone who is using a different function of a familiar device. The technician often finds himself or herself facing a parade of different appliances, each with its own idea of how the controls should be set.

The best teacher for this is time and experience. Even if you're relatively inexperienced with the operation of a specific appliance, there will be certain similarities that will provide at least a starting place. You might even find that there is some logic in the way manufacturers arrange and label the controls.

Whether it be operation, troubleshooting or repair, it helps to understand how things work in general. The remainder of this section will discuss the major parts used in many different kinds of appliances. Specific examples of each will also be provided, with the concentration being on the similarities.

For example, the heating elements in a stove and coffee maker are different, yet are still very much the same. The function and testing of a thermostat is essential the same whether the thermostat is controlling a small warming plate or a housewide air conditioning system.

## **10/TR - A/C • R**

### **Air Conditioners, Refrigerators**

---

## **10/TR - A/C • R - A**

### **An Introduction**

---

#### **General Overview**

As with many large appliances, air conditioners are primarily mechanical and secondarily electrical. There is very little electronics about them except in the control system, and even there the electronics tend to be very simple.

The same is true of system problems. Most are mechanical or electrical. When the problem is electronic, it usually involves some kind of sophisticated temperature control inside the home as part of the thermostat. Such units can rarely be fixed. They have to be replaced as a unit. This is because other than the very common components (such as resistors) replacement parts simply aren't available.

To troubleshoot an air conditioning system you will use your own knowledge of electronics troubleshooting as a starting point. The principles are the same. The problem can only be in so many places. By eliminating those areas which are NOT causing the problem, you'll find the one that IS.

Where you begin is determined by the symptoms. Where you stop is determined by your specific training and available equipment.

Much of the information in this section applies to anything that cools—a household air conditioner, window air conditioner, refrigerator, freezer, etc. As far as the technician is concerned the major differences are in size and voltage.

For example, a household air conditioner uses both 120 VAC and 240 VAC, with the high voltage used to drive the compressor motor.

A window unit, refrigerator or freezer operates by the same principles but uses only 120 VAC. (In addition, most refrigerators and freezers do not use a condenser fan.)

## Refrigeration Basics

To truly understand how air conditioners and heat pumps work, you may have to change your thinking. Basically, there is no such thing as cold—there is only a lack of heat energy. The less heat energy there is, the more cold it seems to be. Imagine having a large block of ice sitting in a confined area. As the ice melts, the area becomes cooler. Or so it seems. What is actually happening is the opposite. As the ice changes from solid (ice) to liquid (water), heat energy is absorbed from the surroundings. In other words, the ice is not adding “cold,” it is taking out “heat.”

The function of air conditioning is to move heat energy. To cool an area or substance, heat energy must be removed. To warm an area or substance, heat energy must be added.

This happens because of the direct relationship between temperature and pressure. As you raise pressure you also raise the boiling point of the substance. Pressure cookers use this same principle. At a pressure of 1 atmosphere (standard), water boils and turns into a vapor (steam) at 212°F (100°C). As the pressure inside the cooker increases, so does the boiling point. The water can be considerably hotter than 212°F but not boil. It will remain in its liquid state.

Likewise, were you to lower the pressure, the boiling point would decrease. Were you to try to pour a cup of water on the moon, where the pressure is nearly zero, the water would boil even as it poured.

This fact is important because an air conditioning system uses changes in pressure to cause the refrigerant to change from a liquid into a vapor and back into a liquid again. Just as important is what happens to the flow of heat energy when there is a change in the state of the matter.

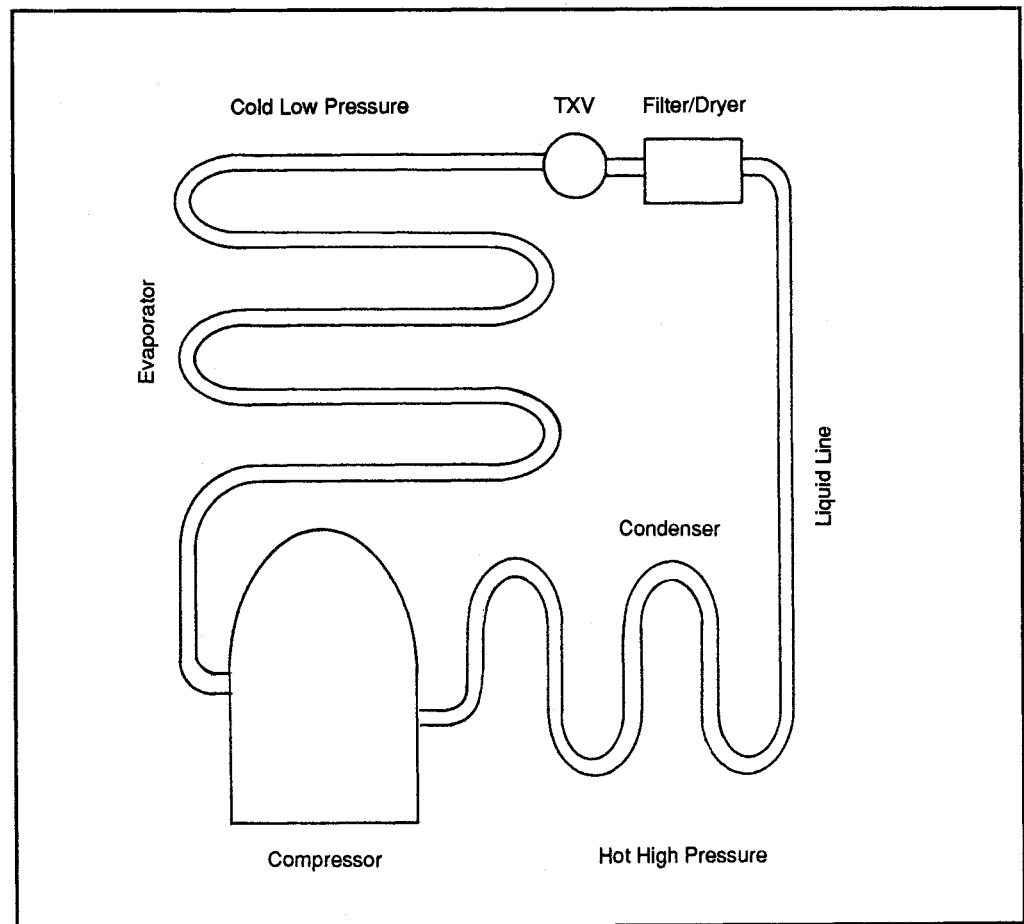
A pan of boiling water at normal pressure is 212°F. Turn up the burner on the stove and you'll be adding more heat energy. You will not be increasing the temperature of the water, only the rate at which it changes from a liquid into a vapor. The heat energy is absorbed as latent heat, which means that all of the energy is being used to change the water from liquid to vapor.

This absorption of heat energy as a liquid changes into a vapor is the key to refrigeration. This happens in the evaporator, with the heat given off in the condenser.

## The Basic Parts

There are four basic parts in an air conditioning system: evaporator, compressor, condenser, and metering device. In the evaporator a liquid refrigerant enters an area of low pressure. This causes it to boil easily, which means that it changes from a liquid into a vapor. To do that it absorbs heat energy. If you blow air over the tubes of the evaporator, that air gives up heat energy to the tubes, and to the refrigerant. The air becomes cooler.

The compressor then squeezes (compresses) the refrigerant vapor. The increase in pressure lowers the boiling point, making it easier for the vapor to change back into a liquid. In the condenser, air blown across the tubes removes the heat energy and the refrigerant changes back into a liquid again.



**Figure 1:** The basic parts of an air conditioning system

The metering device is the spot at which the liquid is “sprayed” back into the low pressure side (evaporator) from the high pressure side (condenser). It meters the flow of refrigerant so that not too much, or too little, passes through.

These are the four basic parts of the system. Each has variations, depending on the system.

**Evaporator**

The evaporator tubing is wrapped back and forth to become a coil. This puts a greater length into a smaller space and allows a greater transference of heat energy. Most often, fins are attached to the tubing, which further increases the effective surface area where heat transfer can occur. The fan used to blow air across the coil and into the area to be cooled is usually of the squirrel-cage type.

**Compressor**

In almost all home air conditioning systems, the compressor is hermetically sealed. It cannot be repaired in the field. In many cases, if the problem is the compressor, the solution is to install a new compressor. However, new EPA restrictions could one day make this impossible. (This depends on the characteristics of the refrigerants used to replace the flouorocarbons employed now.)

**Condenser**

The condenser is much like the evaporator. It consists of a tube that is bent back and forth into a coil, and has fins to increase the transfer of heat. The fan used to blow air over the coil is almost always of the blade (propeller) type. (Note that the condenser of a household refrigerator does not have a fan. This condenser is the large set of coils and wires attached to the back of the unit. It loses its heat by convection, which is why it is important to provide plenty of circulation around the unit.)

**Metering Device**

The kind of metering device used depends on the system. It could be nothing more than a narrow capillary tube with a small orifice at the end. More often it is some sort of automatic valve, the most common of these being the thermal expansion valve, or TXV.

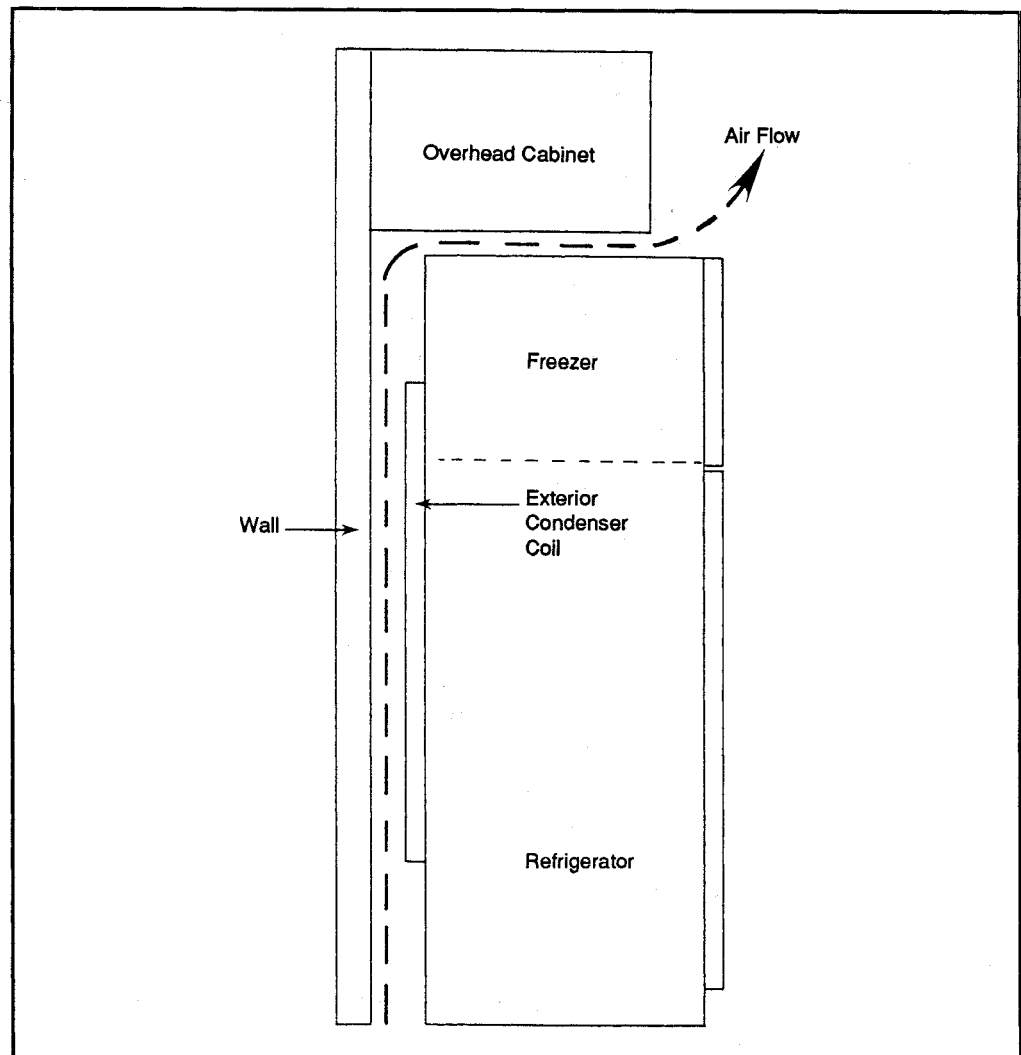
**TXV**

The TXV uses a heat sensing bulb located on the suction line at the end of the evaporator, just before it enters the compressor. The measurement of heat at this point tells the valve if the evaporator is getting too much or too little refrigerant, and the valve adjusts accordingly.

**Superheat**

What is being measured is called superheat. As the liquid refrigerant changes into a vapor, it absorbs heat energy but does not change its own temperature. There is no change in the temperature until all of the refrigerant has become a vapor. It then begins to climb in temperature. This rise above the refrigerant’s boiling point is superheat, and is what the TXV sensing bulb measures.





**Figure 2:** When the condenser does not use a fan, such as on a refrigerator, it's important to provide plenty of circulation. Failure to do so prevents the condenser from losing heat and causes problems.

If the level of superheat is low, the evaporator is receiving too much refrigerant. The TXV valve begins to close to reduce the flow. At the other end, if the level of superheat is too high, the refrigerant is evaporating too quickly which means that there isn't enough refrigerant. The valve opens to increase the flow.

## Heat Pumps

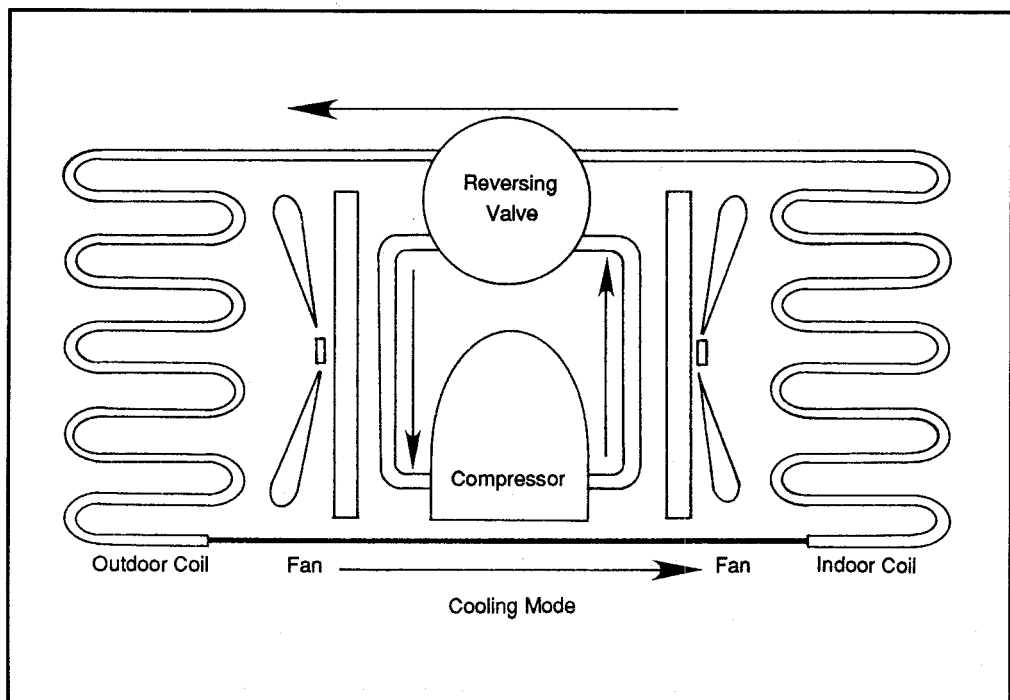
A heat pump operates in much the same way as a standard air conditioner. The

difference is that a reversing valve is used to change the direction of refrigerant flow. In the cooling mode, the flow of refrigerant is the same as in an air conditioner. Refrigerant in the evaporator turns to a vapor and absorbs heat, then changes to a liquid in the condenser and gives off heat. A fan blows air across each of the coils, with the evaporator fan blowing cooled air into the home, and the condenser fan venting heat to the outside.

### Indoor/Outdoor Coil

In the heating mode, the reversing valve changes the direction of refrigerant flow, causing the evaporator to act as the condenser and vice versa. Because of this changing, the coil over which air is blown into the home is called the indoor coil, and the one over which air is blown to the outside is the outside coil. When the unit is in the cooling mode, the indoor coil acts as an evaporator and draws heat from the air. The cooled air is then blown into the home. When placed in the heating mode, the reversing valve changes the direction of refrigerant flow, causing the indoor coil to act as a condenser. The coil is now giving off heat. This warms the air being blown into the home.

In the cooling mode, the outdoor coil acts as a condenser. Inside is hot refrigerant under high pressure. It's hot in part because the evaporator (indoor coil) has absorbed heat from the air blown into the home. A fan blows air over the outdoor



**Figure 3:** Basic operation of a heat pump

coil and the heat is blown into the atmosphere. All this reverses in the heating mode. Now the outdoor coil is acting as an evaporator, which means it is taking in heat from the surrounding air.

This is a puzzle for many people. If the ambient temperature outside is only 35°F, how can heat be extracted? The answer is in the statement at the beginning of this section—that there is no such thing as cold, only a relative lack of heat. Until the temperature reaches absolute zero (which it never does), there is heat energy present. At 35°F, there is plenty of heat energy. To extract it, all you have to do is make sure that the coil temperature is lower than the surroundings.

### Heat Transfer

A practical limit is reached, however. The evaporator can be made to be just so cold. And an additional factor plays a part. The rate of heat transfer is dependent on the difference in temperatures. If the ambient temperature is 60°F and the coil temperature is 34°F, the rate of transfer is fairly quick. If the ambient temperature is 35°F with the coil temperature at 34°F, the rate of heat transfer is very slow. In other words, the efficiency of the heat pump decreases as the ambient air temperature decreases. Eventually a point is reached at which the unit will not function at all. For this reason, many heat pumps are also equipped with one or

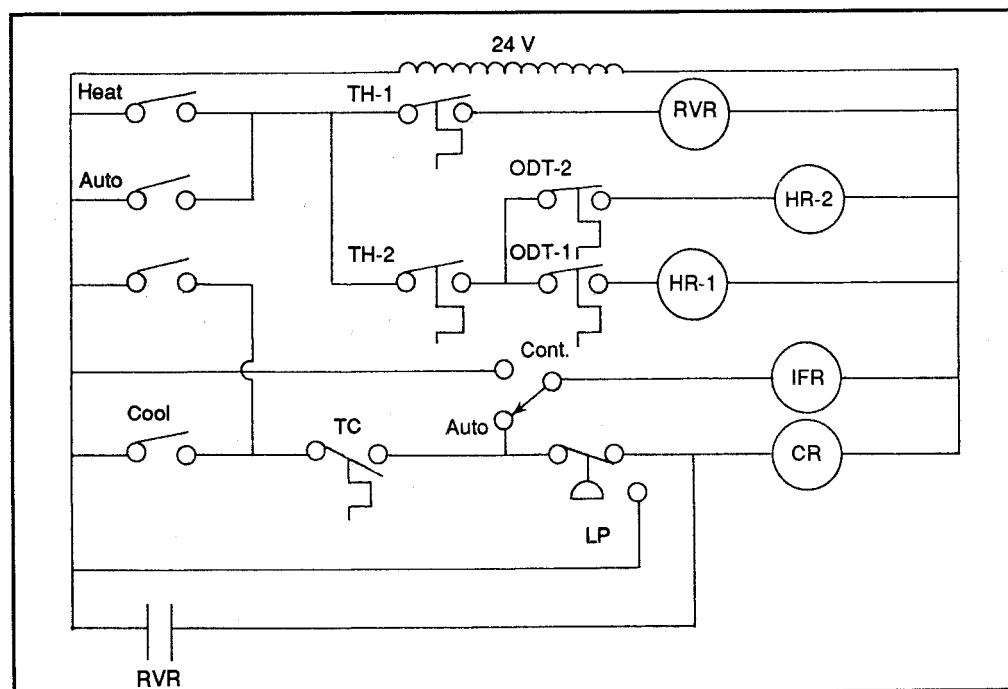


Figure 4: Heat pump wiring diagram showing method for activating auxiliary heat strips

# 10/TR

Troubleshooting

10/TR - A/C • R

Air Conditioners, Refrigerators

10/TR - A/C • R - A

An Introduction

two auxiliary heat strips. These are resistance-type heating elements usually installed in the ducting.

Sensors are used to automatically activate these elements. A common set-up for this is shown in Figure 4.

## Thermostats

When the heat pump is in the heating mode, the HEAT switch is closed. As the temperature in the home decreases the thermostat TH-1 closes. This energizes the reversing valve relay (RVR), which causes the reversing valve solenoid to change position so that the direction of refrigerant flow reverses.

Also located in the inside thermostat housing is a second thermostat, TH-2. This is set to close at about 2 degrees lower than TH-1. That is, if the thermostat setting is at 74°F, TH-1 will close at this temperature and start the heat pump but TH-2 will remain open. If the temperature inside continues to fall—as it will if the ambient outside air temperature is causing a loss of efficiency—TH-2 will close. Outside are two more thermostats, one for each of the auxiliary heating strips.

As the outside air temperature decreases below a preset level, and unit efficiency decreases, ODT-1 will close. This energizes the heating relay (HR-1) which allows the first heating strip to come on. If the temperature outside continues to drop, ODT-2 will close. HR-2 is then energized and the second heating strip comes on.

## System Accessories

### Filter/Drier

Most systems use other parts, which are often termed as “accessories” because a refrigeration system can operate without them. One of the most common is a filter/drier. This device removes moisture from the system. (In the “Warning” section you’ll learn why this is so important, and how even one drop of moisture can cause the system to fail.) Filters/driers may be located almost anywhere in the system.

### Sight Glass

Usually located in the liquid line just before the metering device is a sight glass. This is a diagnostic device the technician can look through as the refrigerant flows through the line. For example, bubbles show that there is either a restriction or that there is air in the line. Streaks show a serious condition of low refrigerant level. Often a part of the sight glass is a moisture indicator which changes color if moisture is present.

### Oil

Oil is needed in the compressor but is not needed (or wanted) elsewhere in the

# 10/TR

Troubleshooting

10/TR - A/C • R

Air Conditioners, Refrigerators

10/TR - A/C • R - A

An Introduction

system. To reduce the amount of oil that circulates, and to keep it in the compressor crankcase, an oil separator might be used. If used, this device is installed just after the compressor.

### Crankcase Heater

Especially in colder areas, the system may use a crankcase heater. The purpose is to keep the oil in the crankcase warm. This makes starting the compressor easier. It also helps to keep refrigerant from mixing with the oil.

### Accumulator

In some systems, the evaporator has an accumulator installed. Its function is to collect any liquid refrigerant that remains so that only vapor goes into the compressor. If liquid gets into the compressor it will cause a condition called liquid slugging, which means that the compressor's piston is literally slamming against the liquid. This can cause serious damage if allowed to continue. An accumulator helps to reduce the chances of this.

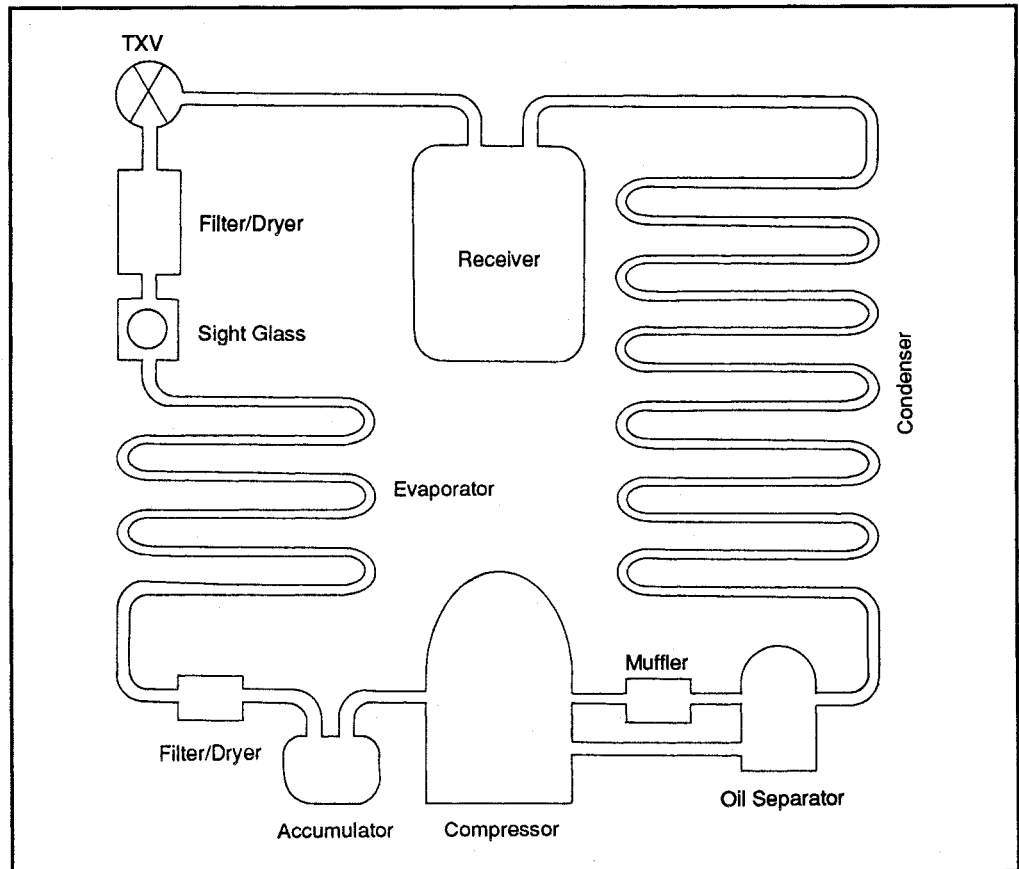
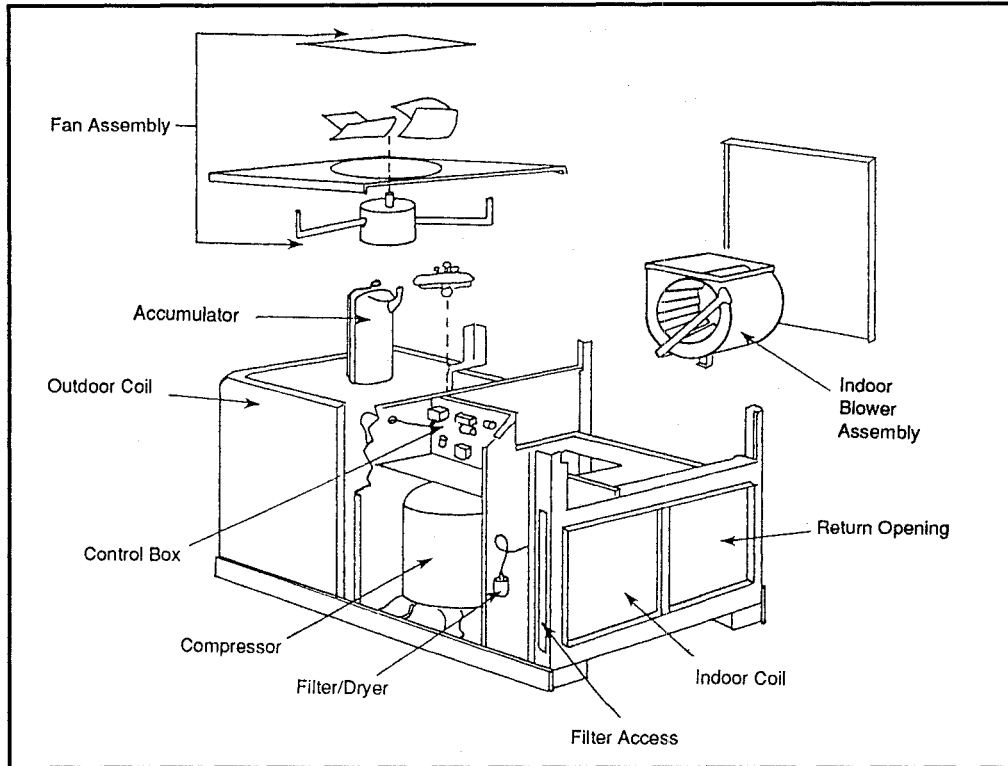


Figure 5: A system with accessories



**Figure 6:** Exploded view of a heat pump

### Receiver

The condenser might use a receiver. This collects and holds liquid refrigerant until needed by the system. The service technician may use the receiver to hold all of the system's refrigerant while performing work on the lines. To do this, he shuts off the receiver's output and has the compressor pump all of the refrigerant into the receiver. Once this is done the receiver's inlet is closed.

### Valves

Throughout the system may be various valves, especially check valves which allow refrigerant to flow in one direction only. Sensing devices, particularly those which measure temperature in different parts of the system, are often employed to assure better control.

### Thermostat

The system will also have a control, the heart of which is the thermostat. These will usually be operating at 24 V, and will use a bimetallic strip and perhaps a mercury switch to send the control voltage to turn on the air conditioner when the temperature inside the home rises above the set level. Also in this part of the system is a transformer to bring the 120 VAC line voltage down to the needed 24 V.

**10/TR**  
Troubleshooting

---

10/TR - A/C • R

Air Conditioners, Refrigerators

---

10/TR - A/C • R - EP

Electrical Problems

---

---

**10/TR - A/C • R**  
**Air Conditioners, Refrigerators**

---

**10/TR - A/C • R - EP**  
**Electrical Problems**

---

**Electrical System**

The electrical system of a household air conditioner consists of the incoming line voltage, usually at both 120 and 240 VAC. The 120 VAC generally powers the evaporator and condenser fans, and the other electrical parts that require the lower voltage. The compressor is usually at 240 VAC. (As above, most refrigerators, freezers and window air conditioners use 120 VAC only.)

Power for household units passes through two high capacity fuses mounted in a box separate from the home's main power box. Usually, the power comes from the meter, through the main circuit panel, through this fuse box and then into the air conditioning unit. Power is then routed to the different circuits.

Because the circuits are actually in parallel, if one circuit goes out, the others will still be active. For this reason, it's very important to understand the schematics used in air conditioning if you are to do electrical troubleshooting.

**Air Conditioning Schematics**

Many electronics technicians can soon become lost when looking at a schematic for air conditioning. One reason is that some of the symbols are unique to refrigeration technology. Another is that the terminology is somewhat different (mostly because of the kinds of components used).

Another cause for confusion is that the structure of the schematic is different. Electronics schematics consist of parallel and series circuits and are dealt with that way.

In air conditioning, there is more concentration on individual branch circuits, each of which is treated as a separate series circuit. The fact that each of these is connected in parallel to all the others is virtually ignored, and can be because of how the system works.

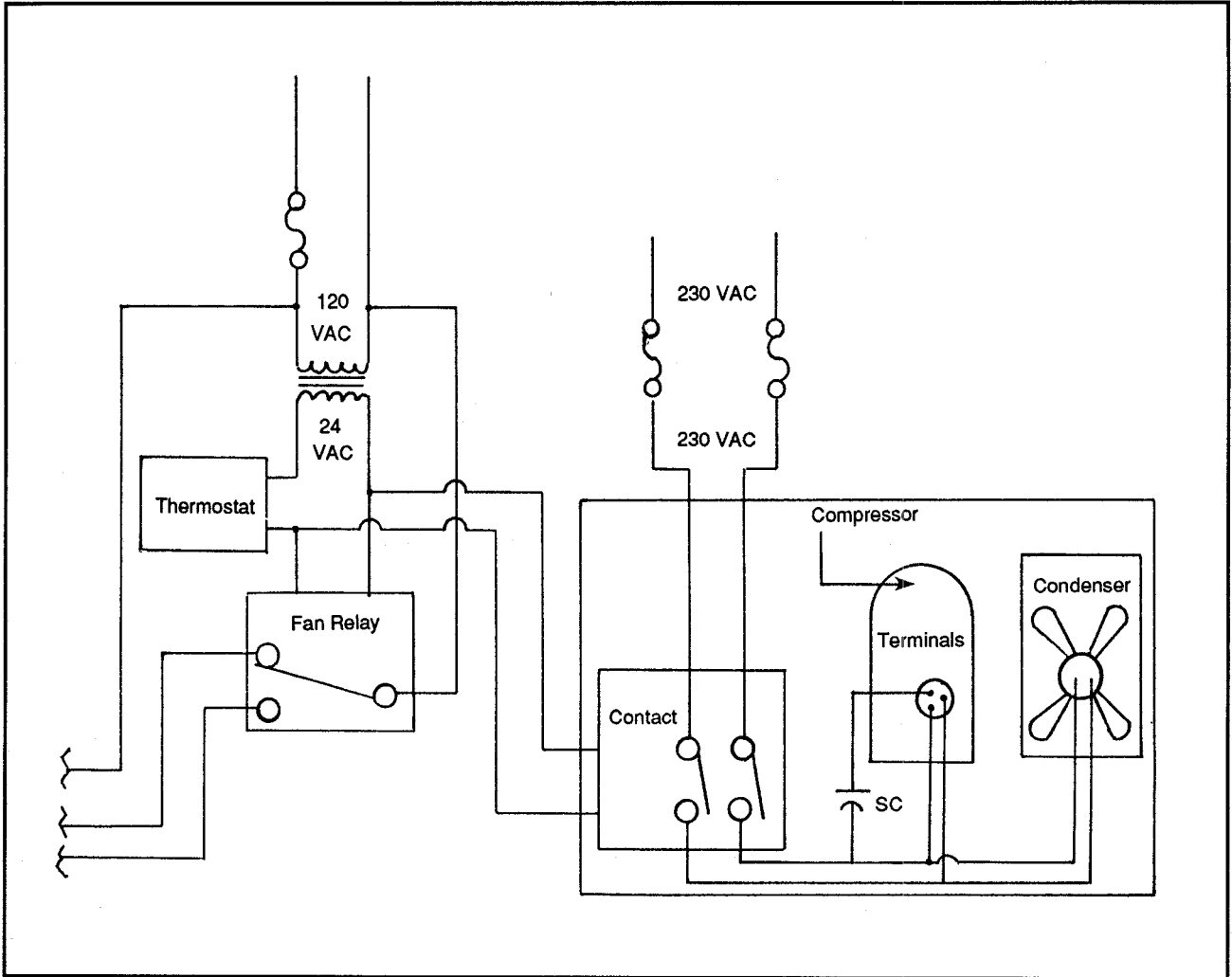
**10/TR**  
**Troubleshooting**

10/TR - A/C • R

Air Conditioners, Refrigerators

10/TR - A/C • R - EP

Electrical Problems



**Figure 1:** A typical electrical wiring diagram for power flow

**Special Schematic Symbols in Air Conditioning**

	SPST		SPDT
	N.O. - N.C. Pressure		DPST



**10/TR**  
**Troubleshooting**

10/TR - A/C • R

Air Conditioners, Refrigerators

10/TR - A/C • R - EP

Electrical Problems

**Special Schematic Symbols in Air Conditioning (Continued)**

	Close/Open on Rise Temperature		Disconnect
	DPDT		Selector
	N.O./N.C. Flow		Power (factory wired) Control (factory wired) Power (field wired) Control (field wired)
	Make N.O./Break N.C.		Single Phase Motor
	Liquid Level		Single Phase Motor
	Make Before Break		Single Phase Motor
	Segment Selector		Three Phase Motor
	Double Circuit Push Button		Three Phase Motor

**10/TR**  
**Troubleshooting**

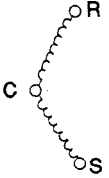
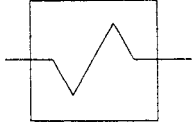
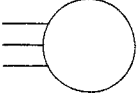
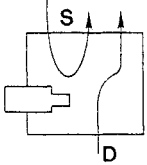

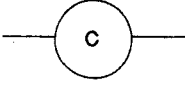










10/TR - A/C • R

Air Conditioners, Refrigerators

10/TR - A/C • R - EP

Electrical Problems

**Special Schematic Symbols in Air Conditioning (Continued)**

	<p>Three Phase Motor</p>		<p>Reversing Valve Solenoid</p>
	<p>Squirrel Cage Induction Motor</p>		<p>Reversing Valve Solenoid</p>
	<p>Thermo Couple</p>		<p>Solenoid Coil</p>
	<p>Voltmeter</p>		<p>Solenoid Coil</p>
	<p>Ammeter</p>		<p>Klixom Relay 2 - Terminal</p>
	<p>Contactor</p>		<p>Male</p>
	<p>Plain</p>		<p>Female</p>
	<p>Colored</p>		<p>Engaged</p>

**10/TR**  
**Troubleshooting**

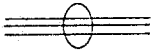
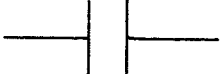


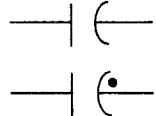


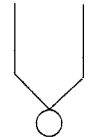
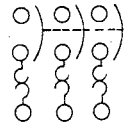

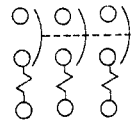

10/TR - A/C • R

Air Conditioners, Refrigerators

10/TR - A/C • R - EP

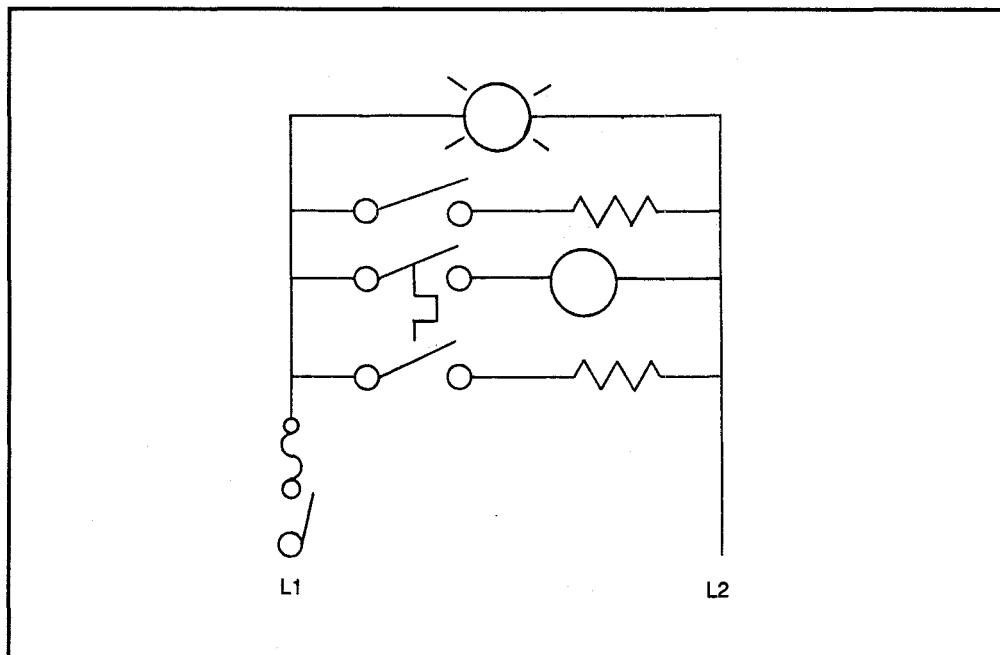
Electrical Problems

**Special Schematic Symbols in Air Conditioning (Continued)**

	Cable		Open Contact
	Shielded Cable		Closed Contact
	Capacitors		Relay Contact
	Fusible Link		Thermocouple
	Thermal Circuit Breaker		Thermo Oveload Coil
	Magnetic Circuit Breaker		Thermal Relay

The rules of electronics still apply. In a series circuit the voltage changes (drops) while the amperage stays the same. In a parallel circuit the amperage changes and the voltage stays the same. In the air conditioning schematic, the voltage is the same through each of the legs.

In Figure 2, each leg is powered because the voltage is the same across each of the series legs. The indicator light will show this. In this particular case, the refrigeration technician referring to the schematic will know to check for voltage drop across the suspected leg when troubleshooting.



**Figure 2:** A simple schematic. Each of the parallel legs is treated as its own series circuit. Note that the “hot” line is labeled L1, and that the electrical return is labeled L2.

As shown in Figure 2, each leg consists of a load (such as a motor, light or the coil of a relay) and a switch to control it. The switch may be a manual (mechanical) switch which has to be physically pushed or flipped, or an automatic switch, such as a thermostat. It may also be the contacts of a type of relay.

It’s important to note that in a refrigeration schematic, the relay appears in two or more places. The coil that activates the relay’s contacts are in one circuit—the contacts are elsewhere. Although this might sound confusing, it is actually done for clarity, and because of what the relay is doing.

Figure 3 is a partial schematic for a heat pump, simplified for easier comprehension. (Note that a real schematic does not have the individual circuits labeled with letters.)

L1 (“hot”) and L2 (return) are both fused. The switches shown are actually together, as a DPST power disconnect switch. Circuit A is the contactor circuit. (A contactor is a kind of relay designed to carry large currents. In this case, the contactor controls the compressor motor.) CR denotes the normally open contacts of the control relay (also labeled CR and located in leg H at the top).

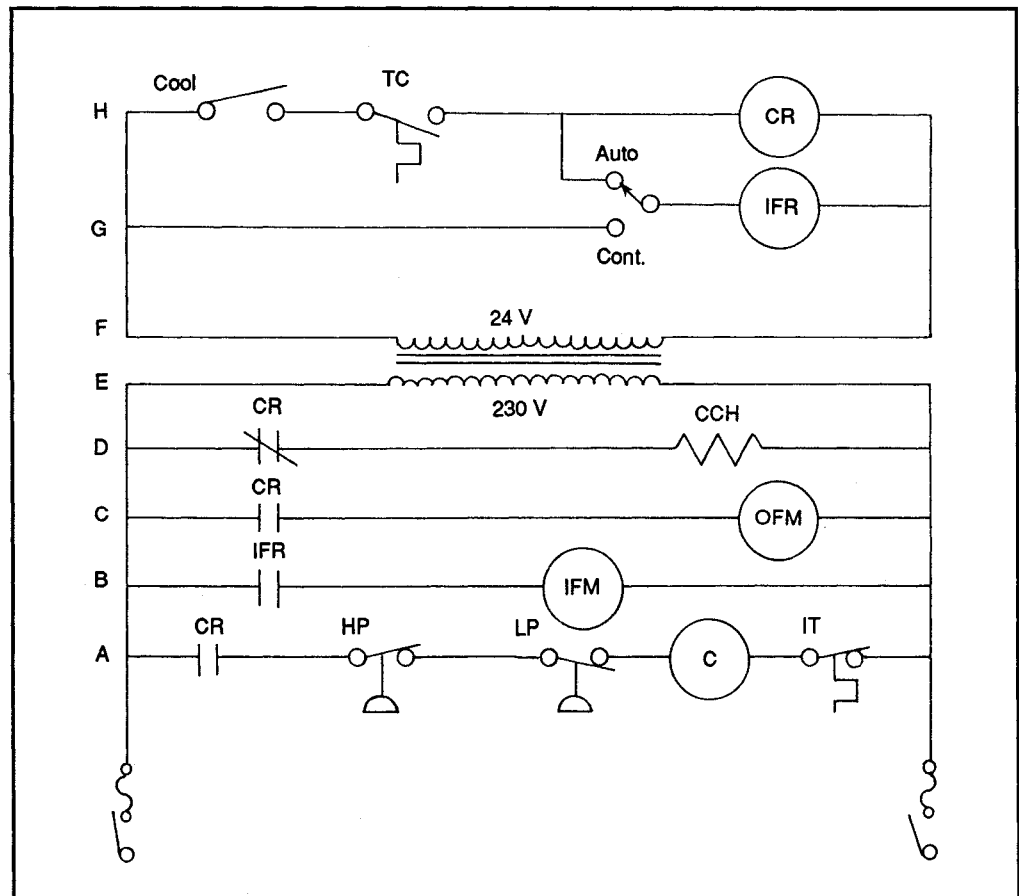


Figure 3: Heat pump schematic

Since these contacts are normally open, the circuit does not carry any power unless the control relay is energized.

#### High/Low Pressure Switch

Protecting the compressor are a high pressure switch and a low pressure switch. If the refrigerant pressure in the system goes above the preset limit, the high pressure switch will open and cut power. If the pressure drops below a preset limit, the low pressure switch will open and cut power. Also shown is an internal thermostat (IT) built into the contactor. If current flow is excessive, this thermostat will open and again power will be cut.

#### Indoor Fan Motor Circuit

Circuit B is the indoor fan motor circuit. This circuit contains the fan motor and a pair of contacts on the indoor fan relay (IFR), which is located in leg G. These contacts are normally open, so no power will go to the fan unless the relay is

# 10/TR

Troubleshooting

10/TR - A/C • R

Air Conditioners, Refrigerators

10/TR - A/C • R - EP

Electrical Problems

energized to close the contacts. Circuit C is similar. Here we find the outdoor fan motor (OFM), and another pair of normally open contacts on the control relay (leg H).

## CCH

In circuit D the load is a crankcase heater (CCH), and a third pair of contacts on the control relay. This time the contacts are normally closed, which means that the crankcase heater stays on when the system is not in use, but shuts off as the contacts open when the control relay is energized.

## Transformer

We next come to the transformer which changes the incoming 230 VAC to the lower 24 VAC used in the control circuits. Keep in mind that although there appear to be two separate sections, the components in the 24 V side are controlling the components in the 230 V side.

Leg G contains a switch that can energize the indoor fan relay continuously, and thus keep the fan running, or can be placed in the automatic setting so that the fan comes on only when the compressor is running.

## Control Relay Circuit

This brings us to the control relay circuit, H. Until the “cool” switch is closed, no power will flow and the control relay will not be energized. Once this switch is closed, current still won’t flow unless the temperature rises above the set level and closes the contacts of the cooling thermostat (TC).

If the cooling switch is turned on (contacts closed), and the temperature is high enough to close the contacts of the thermostat, current flows to the coil of the control relay. The plunger inside causes the three pairs of contacts to change position. The normally open contacts in leg A close, energizing the compressor contactor which starts the compressor. The normally open contacts in leg C close, which starts the outdoor fan that blows air across the condenser coils. The normally closed contacts for the crankcase heater open and this heater is shut off.

## A Complete Schematic

Depending on the manufacturer and the design, a complete system schematic can be very complex or relatively simple. A simple schematic of a typical window air conditioner is shown in Figure 4.

Remember that small air conditioning units like this are designed to operate on the nominal 120 VAC. Consequently, the schematic shows only L1 (hot) and L2 (return). Both the compressor and fan motors are single-phase. These, and the system in general, are protected by a high pressure switch (HP) and a low

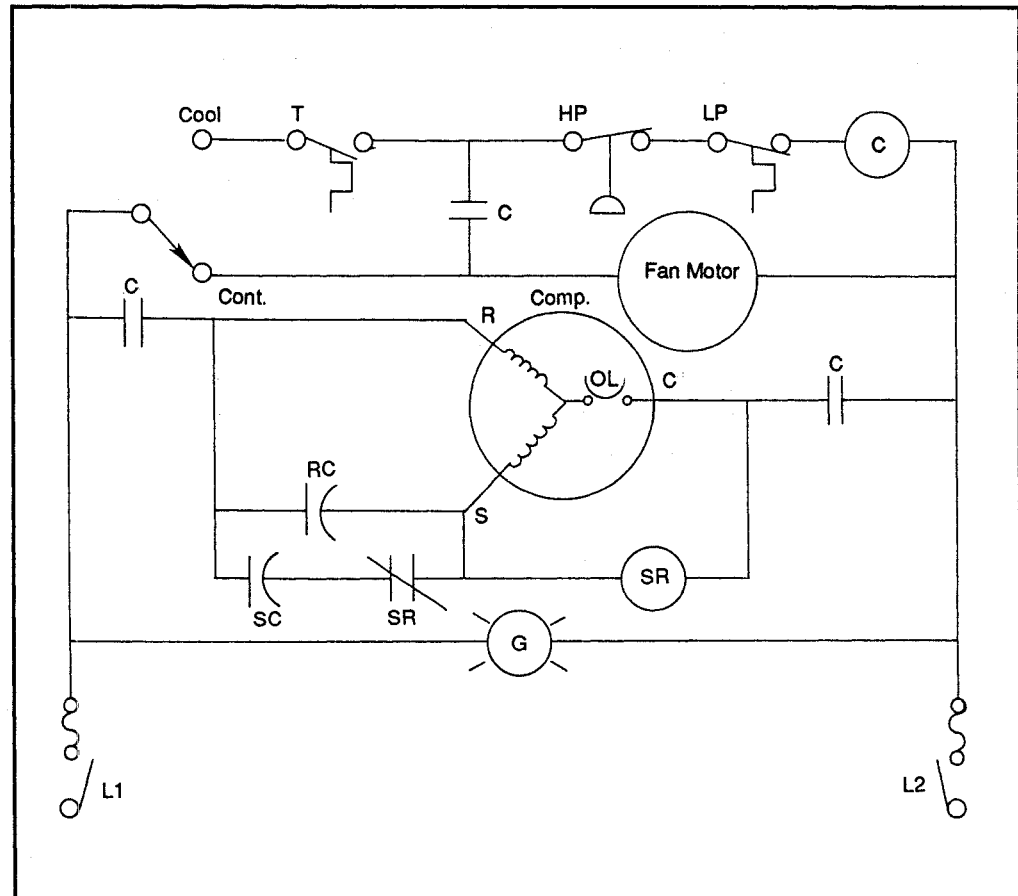


Figure 4: Schematic of a window air conditioner

pressure switch (LP), both in series with the contactor. If the system pressure rises too high, the high pressure switch breaks the circuit and the contactor (C) is de-energized. If the pressure decreases, the low pressure switch will break the circuit and again the contactor will be de-energized. Either way, the contacts to both the fan motor and compressor will open and the system will shut down.

### Klixon

The compressor motor in this unit is internally protected from overload. In this case a temperature sensing Klixon is used. If the compressor motor begins to work too hard, its temperature increases. If the rise is too great, the Klixon releases and contact is broken. The motor shuts off.

### Fan Motor

The fan motor can be set for the fan to run continuously (upper position), or to run only when cooling is desired (lower position). In the COOL position, the circuit is operated through a thermostat (T). Note that this thermostat also

# 10/TR

Troubleshooting

10/TR - A/C • R

Air Conditioners, Refrigerators

10/TR - A/C • R - EP

Electrical Problems

completes the contactor (C) circuit, and that the fan motor circuit has contacts operated by the contactor.

As the switch is placed to COOL, the start relay (SR) activates the circuitry to the start winding of the motor. The relay contacts (SR) are normally closed, which keeps the starting capacitor (SC) “on hold.” The charge in the capacitor momentarily flows through the start winding, giving the motor a “boost” to start turning. The contacts when open and the starting capacitor is taken out of the circuit. This leaves the running capacitor active to smooth the motor’s operation.

## Mechanical Examination

In troubleshooting such a system, you would begin by carefully examining the mechanical parts and conducting a visual examination. Exactly how you proceed depends on the symptoms. (See the Troubleshooting chart.)

Look at the schematic again. Air conditioners virtually always have a number of components designed to protect the system. In this case, there are both high and low pressure switches, plus internal thermal protection in the compressor motor. If the pressure goes up or down, either of the two pressure switches will cut the power. At the same time, these conditions (and others) can cause the compressor motor to overheat. This trips the internal Klixon and again the system shuts down.

A common misconception is that a system that fails to operate means that the compressor has gone out. Compressors are fairly tough by design, and as you’ve seen from the schematics there are a number of components which help to protect the compressor from damage. The compressor is unlikely to be the source of the problem. Suspect first the various components which control and protect it.

A system which starts, or tries to, then stops, is unlikely to have a compressor problem. First check the controlling components, such as thermostats, relays, contactors and capacitors. Any one of these can make a minor problem seem major and all are fairly easy to check with a VOM or DMM. Test for the presence of voltage and for continuity.

For example, the thermostat controls the cooling cycle. When the contacts are open (the temperature is cool enough), there should be infinite resistance across the contacts. As the temperature rises the contacts close. At this point there should be no resistance. If the contacts have closed (or are supposed to have closed) and the resistance across the contacts is still high, the thermostat will have to be replaced.

Much the same is true of the other electrical components. Keep in mind that many



**10/TR**  
Troubleshooting

---

10/TR - A/C • R

Air Conditioners, Refrigerators

---

10/TR - A/C • R - EPElectrical Problems

---

of the control relays and contactors have more than one pair of contacts, each controlling a different leg of the system. Sometimes these contacts are labeled. Other times you'll be able to visually track what each pair of contacts controls. With a little thought, now that you know the fundamentals of how an air conditioner is designed, you should have no problem figuring out if the contacts should be open or closed.

For example, the contacts that control a motor are always the open type. With the system off, the reading across these contacts should be infinite ohms and no voltage or current. If the reading is other than this, the contacts are likely fused shut and the relay unit should be replaced.

With the system on, and the contacts closed, there should be line voltage present across the contacts. If there isn't, something earlier in the line is stopping the flow of power. Test backwards in the line, beginning with the incoming side of the relay or device. If the device is energized but is not responding properly, the device will have to be replaced. If no power is coming in, again something earlier in the circuit is stopping the power.

The same technique applies to all power controlling devices. This includes pressure and flow switches. Testing these for voltage and resistance will indicate either a bad switch or a problem with the system's refrigerant level.

**10/TR**  
Troubleshooting

---

10/TR - A/C • R

Air Conditioners, Refrigerators

---

10/TR - A/C • R - EP

Electrical Problems

---

**10/TR**  
Troubleshooting

---

10/TR - A/C • R

Air Conditioners, Refrigerators

---

10/TR - A/C • R - MP

Mechanical Problems

---

---

## **10/TR - A/C • R**

### **Air Conditioners, Refrigerators**

---

## **10/TR - A/C • R - MP**

### **Mechanical Problems**

---

#### **Introduction**

Mechanical and in particular system (refrigerant) troubleshooting are necessarily limited. However, there are some relatively simple steps that can be taken. (These steps apply to all air conditioning and refrigeration systems, including those of your automobile.)

As stated earlier, most problems are caused by mechanical parts. Squeaks, for example, are a sign of worn bearings or a misaligned motor shaft. If you listen carefully, you can often hear the contacts of a relay open or close. (Keep in mind that the relays and contactors used in air conditioning tend to be rather large.)

In a few cases, repair is possible. You might, for example, be able to clean the contacts of a relay if they have become corroded (although you should investigate the cause of the corrosion if possible). A misalignment may be brought on by nothing more sinister than loose mounting bolts.

Other noises, such as rattling, are often caused by a pipe or line that has become loose. Also, these lines are sometimes passed through bushings or other insulating material. In both cases, the purpose is to absorb vibration. If these parts have come loose or have worn, the lines could begin to vibrate, causing noisy operation.

Especially if you suspect that the system is malfunctioning due to a refrigerant related problem, examine all the lines, and particularly the connections, for signs of a leak. The most common indication is an oily appearance. The refrigerant itself evaporates almost instantly, but since at least some oil is carried through the system, and does not evaporate, a leak is often apparent.

Unfortunately, if this is the problem, there is little choice but to call a certified technician.

# 10/TR

Troubleshooting

10/TR - A/C • R

Air Conditioners, Refrigerators

10/TR - A/C • R - MP

Mechanical Problems

Troubleshooting an air conditioning system is much like troubleshooting anything else. Begin with the symptoms, determine the probable causes of those symptoms, and by the process of elimination locate the source of the trouble. The main problem you will encounter is if the problem has to do with the refrigerant part of the system. As above, this kind of diagnostics and repair has to be left to a certified technician. If your efforts in this regard cause a loss of refrigerant, you'll have only worsened the situation.

The troubleshooting chart below is limited to the things you can check and usually cure.

### Air Conditioning Troubleshooting Table

Problem	Cause	Cure
Poor cooling	Dirty filter Dirty condenser or evaporator coil Damaged coil fins Dirty or broken fan blades Fan motor (s) bad Wind around coils  Low refrigerant or other system problems	Replace Clean coils  Repair, clean or replace Examine, test, replace if needed May be correctable, or you may have to wait Call a certified technician
Low ventilation	Blockage in duct Damage to duct Dirty or broken indoor fan blades Indoor fan motor bad	Examine and clear Examine, repair Repair, clean or replace Examine, test, replace if needed
Unit cycles on and off too often	Thermostat bad Protective device (pressure, flow, level of overload) bad Improper refrigerant level	Test, replace if necessary Test, replace if necessary  Call a certified technician
Solenoid or relay hums	Low voltage Loose connections Sticking valve plunger	Test, correct if possible Examine, tighten connections Replace solenoid unit
Unit is noisy	Mounting bolts loose Compressor is damaged	Check all bolts and screws, tighten Call a certified technician
Unit does not work	No power Blown breaker or fuse  Thermostat bad Relay or contactor bad Protective device bad Control (low voltage side) transformer bad System problem	Test for power Examine, test, reset or replace (but try to find out why it blew!) Test, replace if necessary Test, replace if necessary Test, replace if necessary  Test, replace if necessary Call a certified technician

# 10/TR

## Troubleshooting

10/TR - A/C • R

Air Conditioners, Refrigerators

10/TR - A/C • R - MP

Mechanical Problems

Refrigeration Troubleshooting Table (Continued)

Problem	Possible Causes	Symptoms
Reduced Air Flow	Dirty condenser or evaporator coils Damaged cooling fins Air flow restriction(s) Fan blades or motor(s) Overload devices tripping Loose fan belt Improperly adjusted pulley Improper unit ventilation	High suction and head pressure Flooded evaporator Possible liquid slugging Insufficient superheat in suction line Insufficient sub-cooling in condenser
Refrigerant Overcharge	Too much refrigerant	High liquid level High suction and head pressure Flooded evaporator Liquid slugging in compressor Excessive sub-cooling
Refrigerant Undercharge	Leak Improperly charged refrigerant	Starved evaporator Low suction and head pressure High superheat Reduced cooling Flash gas in liquid line (shows as bubbles in sight glass) Frost line on evaporator line
Compressor Pumping Poorly	Blown head gasket Bad compressor valves	Noise Improper cooling Overheating
Compressor Overheating	High voltage Low voltage Refrigerant undercharge Oil undercharge Excessive evaporator load Bad valves	Noise Improper cooling Burned out compressor
Compressor Seizure	Refrigerant floodback Flooded starts (due to oil migration) Oil trapping Insufficient oil Insufficient refrigerant Compressor burnout	System failure/shutdown
High Head Pressure	Refrigerant overcharge Reduced air flow	Hot liquid line Intermittent bubbles in sight glass
TXV Overfeeding	Improper superheat setting Improper sensing bulb placement Loose sensing bulb Excessive oil in system Wrong type of TXV Bad or sticking TXV	Evaporator flooding High suction pressure Low sub-cooling in condenser Compressor runs cooler
TXV Underfeeding	Improper superheat setting Improper sensing bulb placement	Starved evaporator Low suction pressure

# 10/TR

Troubleshooting

10/TR - A/C • R

Air Conditioners, Refrigerators

10/TR - A/C • R - MP

Mechanical Problems

Refrigerant Troubleshooting Table (Continued)

Problem	Possible Causes	Symptoms
TXV Underfeeding (cont'd)	Loose sensing bulb Bad sensing bulb (loss of internal refrigerant) Plugged drier Restriction in TXV inlet screen Plugged line(s) Refrigerant overcharge Wrong type of TXV Bad or sticking TXV	Low head pressure High superheat in suction line High sub-cooling in condenser Frost or ice on evaporator
Erratic TXV Operation	Oversized TXV Rapid evaporator load changes Very light evaporator load Flash gas in liquid line	Low or high suction pressure Low or high sub-cooling in condenser Evaporator flooding or starved evaporator Improper cooling

## Sight Glass Readings

Sight Glass Indication	Possible Causes
Clear Sight Glass	Proper refrigerant charge Overcharge No charge
Bubbles in Sight Glass	Refrigerant undercharge Liquid line restriction Air or moisture in system
White, Foamy Bubbles in Sight Glass	Dessicant core in drier breaking down
Oil Streaks in Sight Glass	Extreme undercharge No refrigerant

**Warning!**

Unless you have the proper training and equipment you are strongly advised NOT to attempt work on the system in any way that will affect the refrigerant level. That is, while you can work on the electrical and electronic parts of the system, don't attempt repairs to the compressor, tubes or coils. There are a number of reasons for this.

**Government Regulations**

As of July 1, 1992 new regulations went into effect that limit and will eventually ban the release of any fluorocarbon into the atmosphere. More and more suppliers won't even sell refrigerants to anyone who is not certified. So far, getting certified isn't difficult. It has been predicted that the testing for certification (or re-certification) will become more and more difficult.

If you make a mistake and allow even a small leak, the refrigerant level will decrease and you won't have any way to replace the lost refrigerant. This in turn will cause the system to function less efficiently and could cause it to fail completely. If too much refrigerant has escaped, the system could self destruct. As refrigerant escapes, so does oil. This oil isn't needed in most of the system but is critical in the compressor. If the level is too high or too low, the compressor will almost certainly be damaged.

It's possible to recover the refrigerant, to complete the work and to then put the refrigerant back in. This will be allowed by law but is a complicated process involving expensive equipment. It also brings considerable risks. (The same is true of doing any work in this part of the system.)

Great care is taken by manufacturers to be sure that the refrigerant is uncontaminated. The two worst contaminants, often introduced by a careless technician or improper procedures, are air and water.

### **Air in the System**

Air takes up space in the system. This isn't as critical in the evaporator, but can reduce the cooling available. In the condenser, as the refrigerant changes back into a liquid form, the air does not. This creates bubbles which can cause a variety of problems. The liquid refrigerant is purposely kept right on the edge of turning back into a vapor. It's designed to do this when the pressure drops. Air bubbles cause small areas where the pressure is lower than in the surrounding liquid. This can cause the liquid to "flash", which means it turns back into a vapor and changes temperature quickly. The system is supposed to do this through the metering device and in the evaporator, but NOT in the condenser.

### **Moisture in the System**

Worse is that air can contain moisture. Moisture of any kind, in any amount, in the system is disastrous. Depending on its size, the average home air conditioning system will contain somewhere between 10-15 pounds of refrigerant. If there is as little 1 or 2 drops of water in that, the system will quickly degrade.

### **Icing**

One of the simplest and least destructive things that can happen is icing of the metering device. The temperature there is below the freezing point of water. Remember that water expands when it freezes. This can cause the orifice to clog, partially or completely. If the refrigerant flow stops, the system just isn't going to work. It's possible that damage could result.

### **Chemical Reactions**

Worse are the chemical reactions, and the worst of these is a reaction with the copper in the system. The copper may be dissolved. Heat, especially in the compressor, causes the dissolved copper particles to be desposited on any parts

**10/TR**  
Troubleshooting

10/TR - A/C • R	Air Conditioners, Refrigerators
10/TR - A/C • R - MP	Mechanical Problems

that are made of iron or steel. The effect is almost the same as if you electroplated the copper onto the steel.

Clearances of the bearings and other mechanical parts are critical. As copper gets plated onto the parts, the clearances are reduced. Friction increases. Efficiency decreases, heat and current draw increase. In time the compressor will seize.

Once again, you are strongly advised to leave this kind of work to trained professionals with the proper equipment. It is too easy to cause irreparable damage to the system. Imagine making a mistake and releasing all the R-12 refrigerant. R-12 is no longer available, and there is not (as yet) a legal substitute. A relatively simple problem can easily become a complicated and expensive mess. Due to the cost, it is often less expensive to replace the entire unit.



# 10/TR

## Troubleshooting

10/TR - C

Controls

## 10/TR

### Troubleshooting and Repair

### 10/TR - C

#### Controls

#### Overview

Many controls are mechanical or electro-mechanical in nature. A simple 2-pole switch uses a mechanical (physical) motion to make or break a contact. More complex switches will allow positioning of the contacts to operate a choice of functions. Other controls allow adjustments via changes in resistance or capacitance. Some are spring-loaded and thus perform functions such as “temporary on” (the sending of a temporary electrical pulse) or perhaps allow timing.

The problem is that anything mechanical is subject to mechanical wear. Not only can the control itself wear as a whole, the contacts inside can wear and can corrode. It’s not uncommon for an appliance or other device that is in perfect working condition to fail because a mechanical switch has worn out.

#### Testing

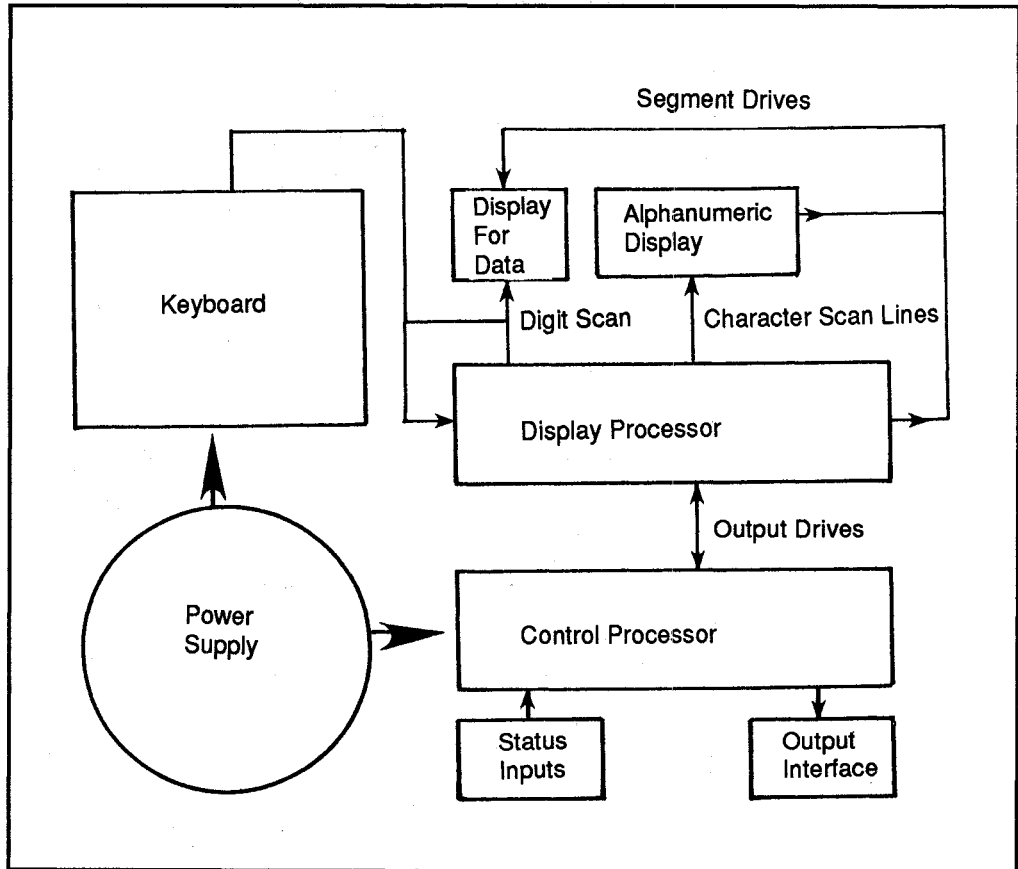
Testing of such controls is almost always a matter of using a DMM to check for continuity and shorts. That is, when the contacts are in place the resistance should be  $0\ \Omega$ , while when the contacts are not in place the resistance should be infinite.

This kind of control is still the norm. Various electronic controls which limit physical motion are becoming more common.

#### Electronic Control Panels

Electronic control panels for various electronic devices in the home can vary greatly in the number of buttons and the number of controls they support. For example, a typical microwave oven control panel may offer 18 or more different buttons to control each of the functions of the microwave. When multi-function panels such as this are provided, the signals are usually processed by an onboard microprocessor.

Figure 1 shows a typical microprocessor control section. This particular section is controlled by a Hitachi HMCS 45A microprocessor. The driver uses some 44 I/O lines to input information and control various aspects of the microwave. Figure 2 shows a section breakdown of how these interrupts connect to the keyboard. Checking each of the I/O lines with a logic probe is an easy method

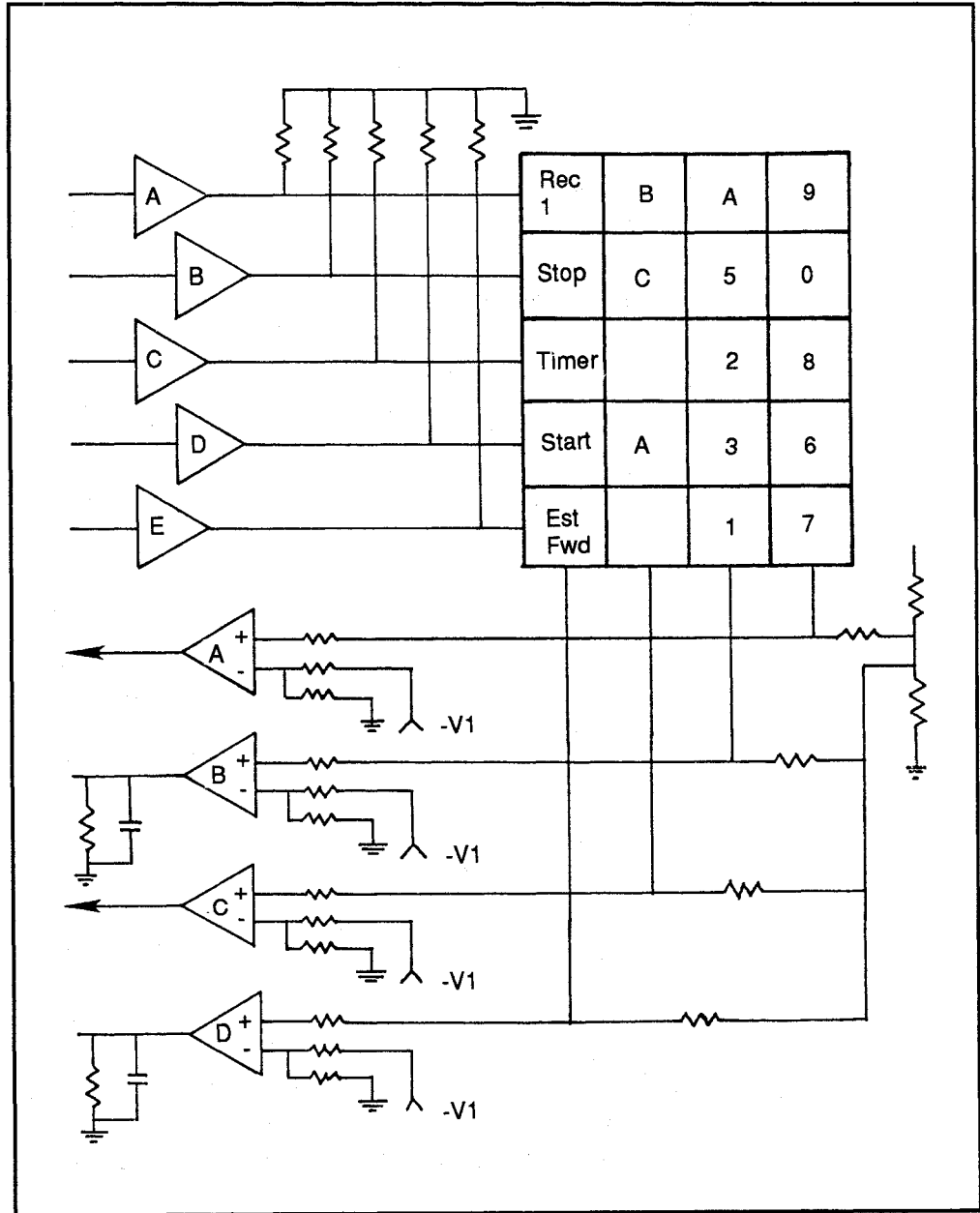


**Figure 1:** Typical processor control block diagram

for determining if problems are occurring in switch or I/O lines.

Touching a key inserts a capacitance between the drive pad and signal ground. This forms an AC voltage divider and the signal which is applied to the comparator that is reduced in half. This is not enough for the output to change states and the microprocessor sees the absence of a signal as a key being pressed. This is then converted and processed by the control microprocessor and activates the required function for the microwave.

Much the same is true in any multiple-control panel. It should be noted that it isn't uncommon for the panel to be built and installed as an assembly. Replacing just one of the button switches (usually of the membrane type) is often difficult or impossible. The best you may be able to do is to gain access to the processing chip, test it for incoming signals with a logic probe and determine if the control panel or the chip must be replaced. Quite often both are the same, since the microprocessor is mounted to the control panel circuit board.



**Figure 2:** Interrupt connections to keyboard

Most other testing requires either the specific service manual or some good guessing. For example, you may be able to trace the wiring responsible for a certain function from the switch to the chip, from the chip to the outlet plug or some other combination.

# 10/TR

## Troubleshooting

10/TR - C

Controls

### Fuzzy Logic

Fuzzy logic is finding its way into microwave ovens and other appliances. Fuzzy logic stems from the fuzzy set theory proposed by Lofti Zadeh in 1965. It has been only recently that these theories have been put to use. Conventional theories say that an object is either in or out. For example, the numbers 2 and 4 are in the set of even numbers and the number 3 is out. Zadeh's theory allows an object to have a partial membership, which means that an object can be sort-of in and sort-of out. (2.03 is sort-of even). With this, a state doesn't necessarily have to be just on or off, it may also be sort-of on, or sort-of off.

Partial membership then approximates human reasoning and lends itself to automation. Microcomputers can make faster decisions based on sensor data and can be programmed faster if using fuzzy logic. The value of this predicts that fuzzy logic devices will become more and more common in the future.

Sharp Electronics now has available a fuzzy-controlled microwave that, at the touch of a button, can grill, roast, or bake a variety of items such as cookies, bread, chicken, meat, and fish. There are various built in sensors which "talk" to the microprocessor to determine the type, shape, height and quantity of food in the oven. It then automatically calculates the optimal degree of "doneness" and the ideal heating time.

Other options include the one-touch reheating and defrosting button. Humidity and aroma sensors can help decide if the job is done.

### Fuzzy Vacuum Cleaners

Some modern vacuum cleaners are using fuzzy logic controllers. For example, a dust sensor can be used to determine how much sucking power should be supplied. The sensor's voltage is converted to a fuzzy variable and then the microprocessor determines how hard the vacuum should suck up the dirt.

Fuzzy logic vacuum cleaners are made by Hitachi, Sharp, and Matsushita and can also determine the type of floor surface being cleaned and adjust accordingly. The change in dust flow determines where the dust is coming from. A wood floor, for example, will allow dirt to flow faster than a shag carpet which would release dirt more gradually.

Matsushita uses a 4-bit microprocessor in its fuzzy logic vacuum cleaners. The chip pulses an infrared LED and monitors the output of a phototransistor. As dust passes between the two components, it blocks light and changes the output signal. The fuzzy logic infers and the computer adjusts suction power and then controls the motor fan speed.

**10/TR**  
Troubleshooting

---

10/TR - C

---

Controls

---

---

**Conclusion**

Many appliances are becoming available that have electronic controls. Many are microprocessor based (simple microprocessors) and can be easily checked with logic probes, and IC checkers. The service manual for each specific unit will indicate proper test points and levels to be found. Replacement parts can usually be easily obtained from the manufacturer or local authorized service representative. IC component boards for many of these simple appliances must be replaced as a whole. Parts for many of these devices may be found at local electronic stores, but as items become more and more sophisticated, the number of proprietary ICs being used increases.

**10/TR**  
Troubleshooting

---

10/TR - C

---

Controls

---

---

## 10/TR

### Troubleshooting and Repair

## 10/TR - ECM

### Electronically Controlled Motors

#### Electronically Controlled Motors

Many devices in the home may have some kind of motor within it. Advances in magnetic materials technology and ICs have led to the rise in popularity of brushless DC motors. To control these devices a variety of linear controller ICs are making many features and advantages of brushless motors available at an economical price.

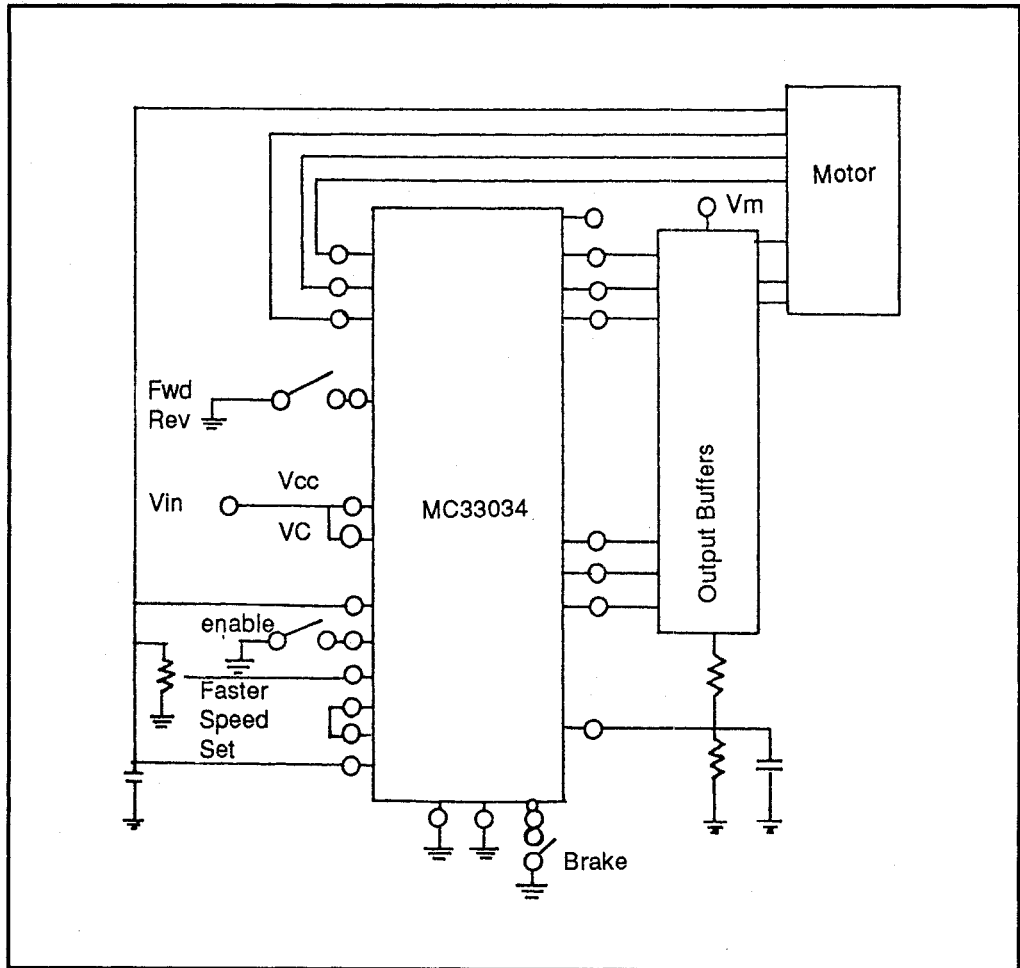
These IC-based controllers are now offering capability and control at a fraction of the cost of discrete component controls. These kinds of controllers may be found in a variety of appliances, from the smallest appliance to the air conditioning and heating system for your home.

#### MC33034 Brushless Motor Control

Figure 1 shows an arrangement with an IC and a motor that is capable of controlling a 3- or 4-phase motor. The system can drive a motor in forward or Motor Control reverse; provide dynamic braking control; speed control; or run enable controls. Cycle-by-cycle current limiting, under voltage lockout and internal thermal shutdown protection are also provided.

This IC operates at a temperature compensated for 6.25 V reference power. If there are problems with this type of circuit, most likely it will be in the motor and not the IC. The IC is merely the switching controller for the motor. To test this circuit, try each of the different functions first to determine what works and what does not. If the motor will not turn, or hums when trying to turn but does not turn, the motor is bad and should be replaced.

It is possible that the IC is at fault. To check if the IC is causing the problem, try the motor without the IC connected and power each of the windings separately. If the motor works without the IC connected, chances are good that the IC is at fault and should be replaced.



**Figure1:** MC33034 IC controller with motor attached

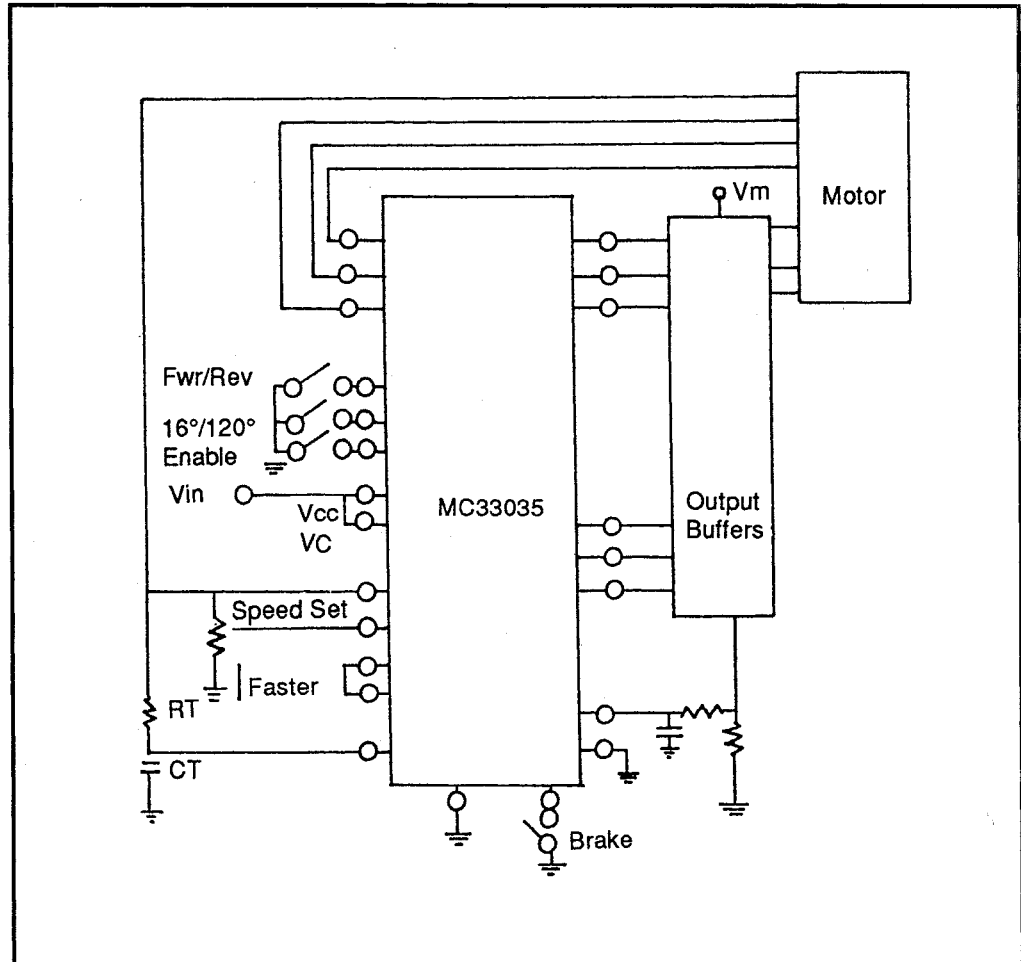
The MC33035 is a high performance brushless DC motor controller that contains all of the active functions of the MC33034. It also allows the user to select 60/300 or 120/240 sensor electrical phasing and access to both inverting and noninverting inputs of the current sense comparator.

Phase controlling can offer some additional faults that will need to be checked completely before replacing either the motor or the IC. Check (as before) all functions and the motor isolated from the IC before replacing.

### TDA1085A Universal Motor Speed Controller

At times a motor must be able to operate at variable speeds for different applications. A simple version of this would be an oscillating fan that must be able to operate at three different speeds to allow different amounts of air flow. One way to control the motor speed is with a chip. The TDA1085A is one such IC that would be able to control either an AC or DC motor in an open or closed loop configuration.





**Figure 2:** MC33035 IC controller hooked to a motor

The TDA1085A is shown in Figure 3. In this configuration the IC allows the device to operate in one of three different speeds. Bypassing the IC and checking the motor with current hooked directly to it will determine if either the IC is the cause of the problem or if the motor itself is the problem. The TDA1085C is similar to the TDA1085A but is found more often in commercial washing machines. This chip, and others similar, can also be found in a wide variety of applications.

**10/TR**  
Troubleshooting

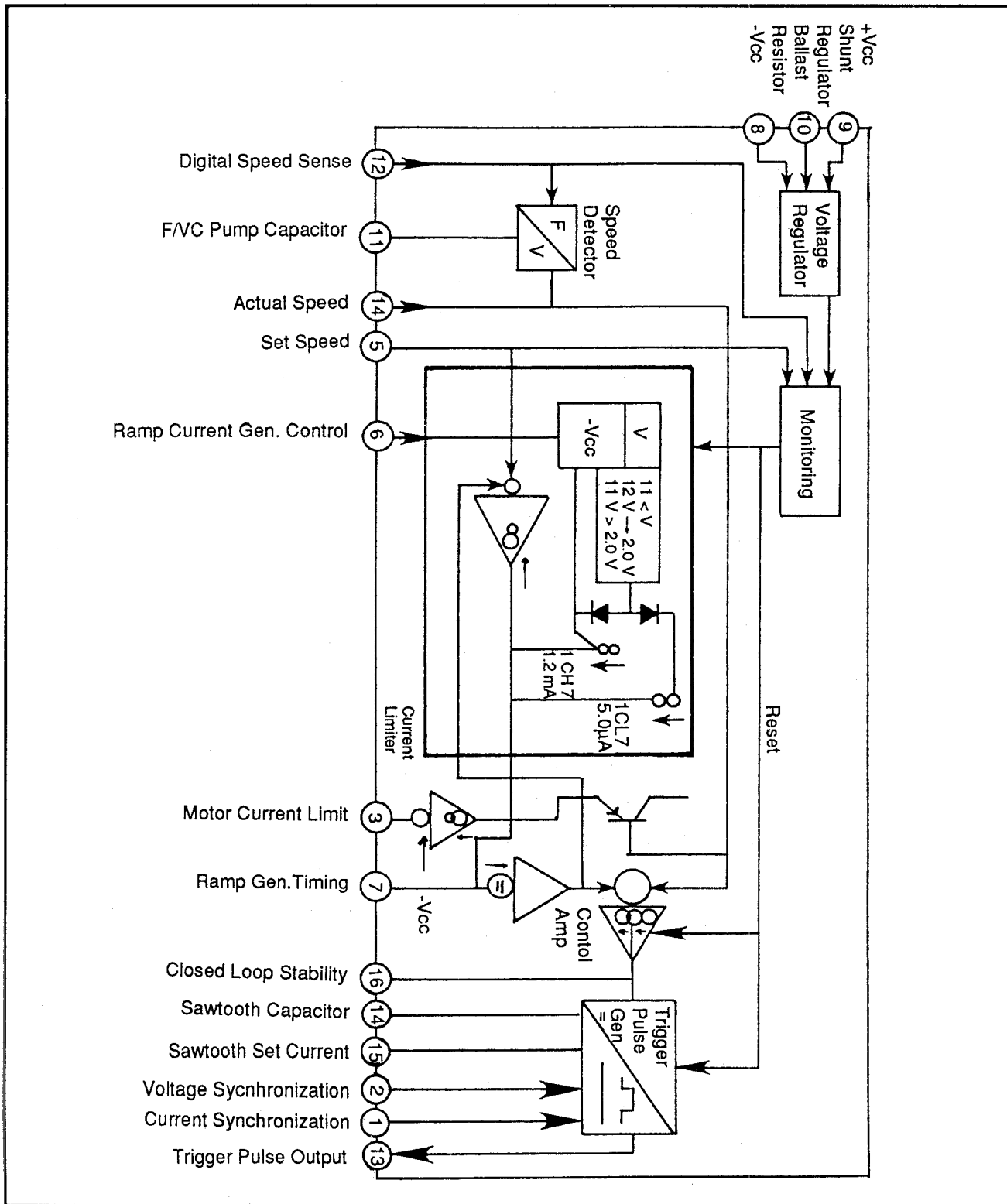


Figure 3: TDA1085A in fan motor shop

# 10/TR

Troubleshooting

10/TR - T

Transformers

## 10/TR Troubleshooting and Repair

### 10/TR - T Transformers

Transformers change one value of voltage and current to another. In most appliances in which transformers are used, the component will step-down (reduce) the voltage from the standard 120 VAC to values such as 18 or 24 VAC.

#### Testing

Testing the transformer can be done in several ways. While in-circuit, the DMM is used to test for voltage coming to the component and for voltage coming out. Out-of-circuit, a DMM set to read resistance should show very low resistance in a winding, and an infinite resistance between windings (i.e., between the primary and secondary windings). Specific tests as they apply in practice are detailed below with the examples given.

Probably the most common use, as far as household appliances are concerned, is the doorbell.

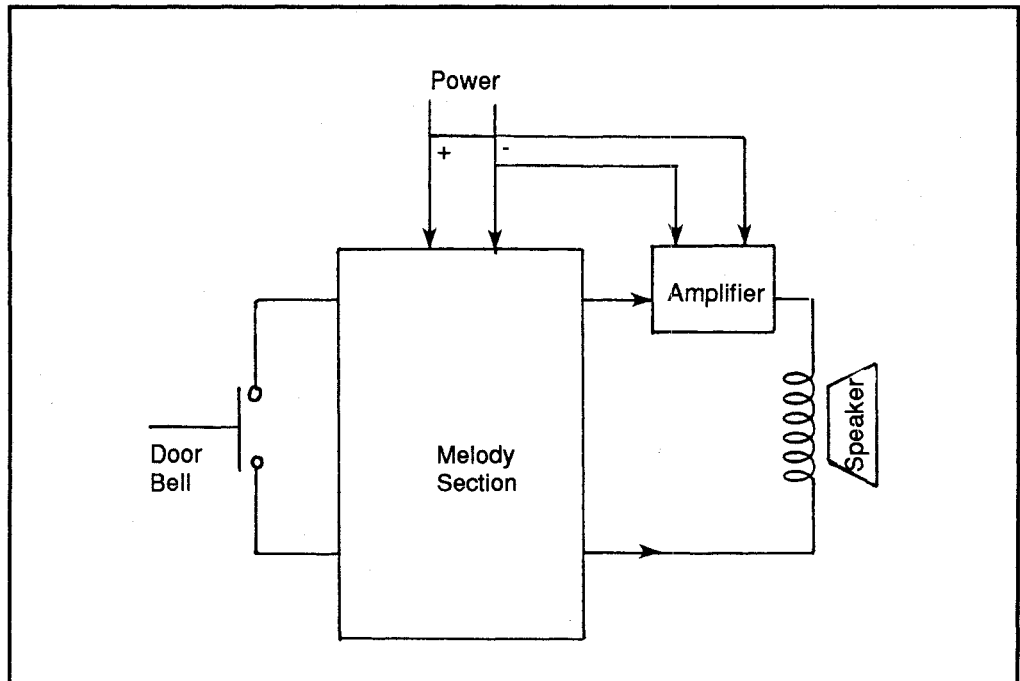
#### Electronic Doorbell

A typical low voltage application is that of a doorbell circuit. Figure 1 shows the circuit hookup for an electronic doorbell hooked to a home. Troubleshooting and repairing such a device is straight forward.

First make sure that voltage is getting to the transformer and that it is coming out. Input will be the standard 120 VAC nominal. Output will generally be between 14 and 24 V but may vary. The actual output value is rarely critical as far as testing the transformer is concerned. If there is an output voltage across the secondary, the transformer is probably performing correctly.

Next ensure that power is getting to the doorbell switch, and that it is coming out when the button is pushed. To test for power coming to the switch, simply check across the wires on the input side. If the transformer is supplying voltage but none is found at the switch, you know that there is a break in the wires between the transformer and the switch.

To test for power on the output side of the switch, test across the wires when the button is pushed. A voltage reading should be present. If voltage gets to the



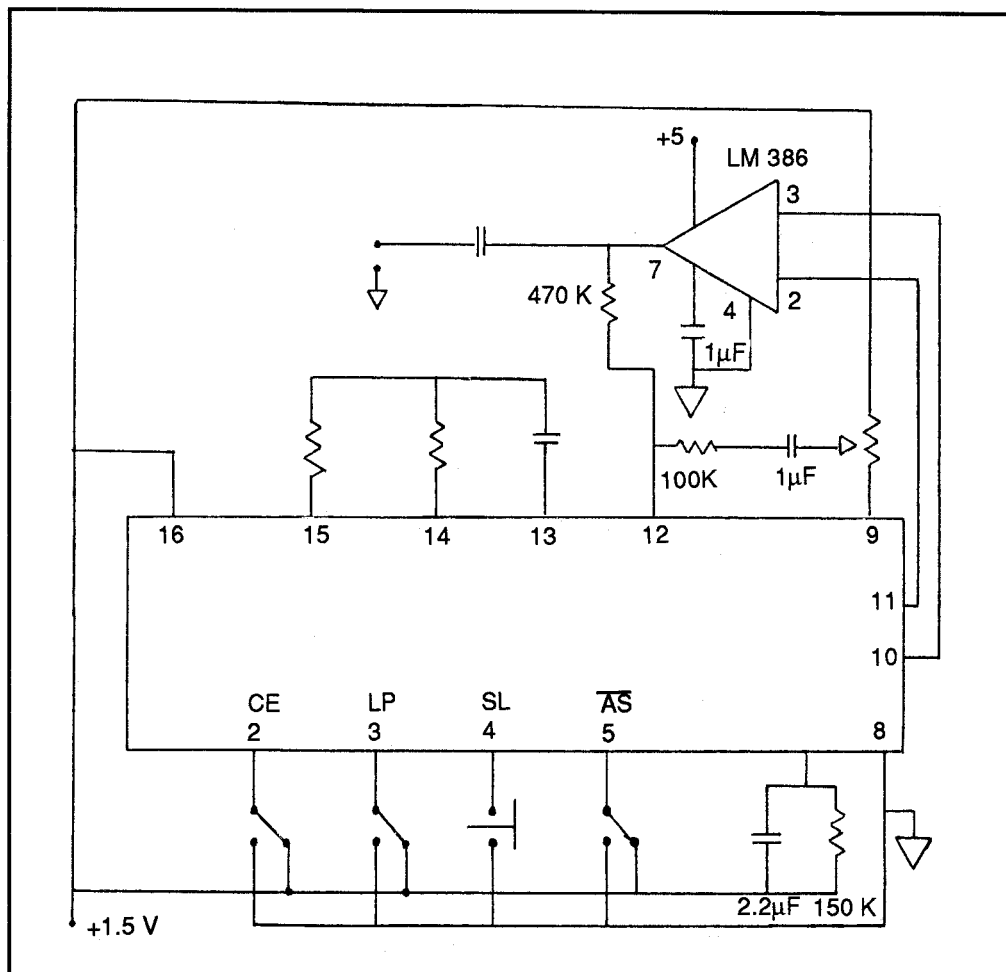
**Figure 1:** Electronic doorbell circuit arrangement

switch but doesn't go through when the switch is pressed, the switch is bad and must be replaced.

Next test for voltage at the doorbell itself. You should get a voltage reading at the doorbell input of the same value as was output at the transformer. If you don't, there is a break in the wire between the switch and the doorbell.

If power is getting to the doorbell device but it is not working, something is wrong with the doorbell. This could be a unit failure or could simply mean (if it is an electronic device) that you haven't selected one of the programmed tunes or chimes. If the unit has failed, you will probably have to replace it as a whole. These devices are usually single chip (IC) driven, and it's somewhat difficult to find just the replacement chip. You can, however, test the chip.

Figure 2 shows a simple melody doorbell based on the UM3482A chip. This chip has twelve different songs built in with no provision for adding more. It is a multi-instrument melody generator using the newest ROM CMOS technology. The chip is designed to play melodies according to preprogrammed data. The data is placed into the ROM memory during the manufacturing process. Because of this configuration, information is permanently stored internally and does not

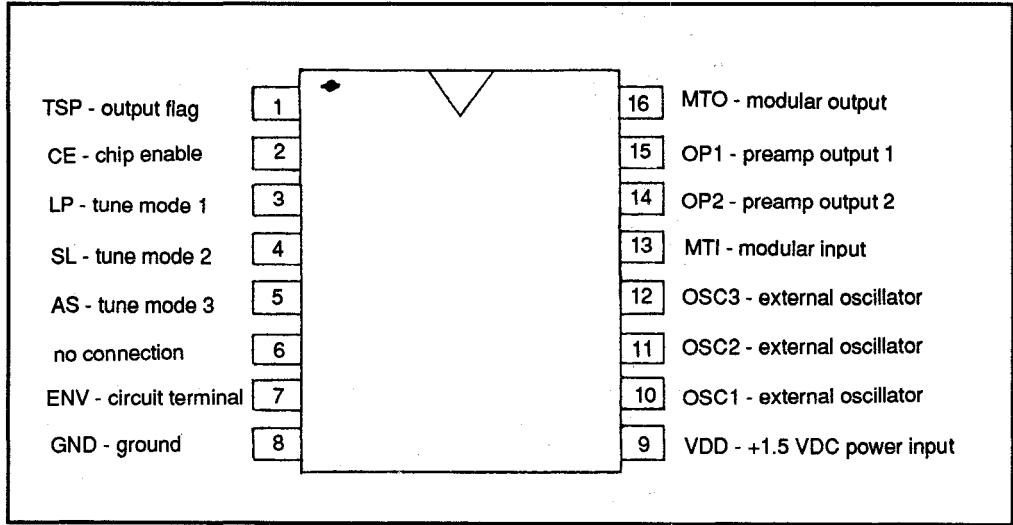


**Figure 2:** Melody doorbell using the UMA3482A chip

require CPU support to reload this information every time power is removed from the circuit. The internal storage is in 512 seven-bit words with three instrument sounds (piano, organ and mandolin).

To test the IC, a logic probe can be used to check the states at the various pins. Figure 3 shows the logic that can be found at the pins.

If the voltage for the IC checks out OK, but the logic does not, suspect the IC is bad and replace it (if you can find a replacement chip). If the power is correct and the IC logic seems fine, suspect that the speaker and/or amplifier sections are not functioning properly.



**Figure 3:** Logic on the UM3482A doorbell music chip

# 10/TR

Troubleshooting

10/TR - Th

Thermostats

## 10/TR

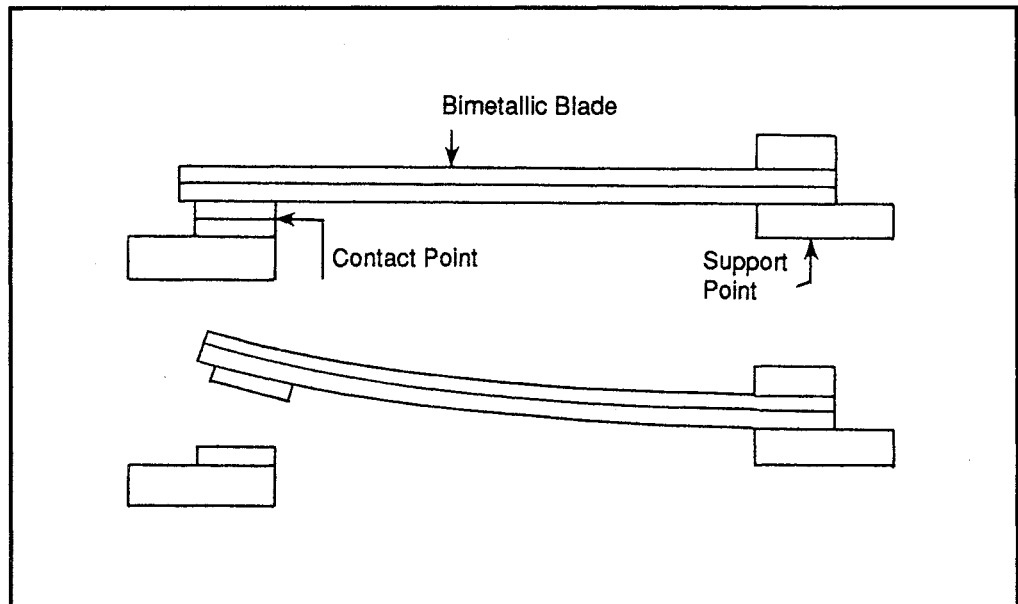
### Troubleshooting and Repair

### 10/TR - Th

#### Thermostats

Thermostats are used in virtually every appliance (and in many other places) where heat or cold must be controlled. Most work on the same basic principle, which is that different substances expand and contract at different rates when the temperature changes.

#### Bimetallic Strip



**Figure 1:** A basic bimetallic strip

The most common form of thermostat is a bimetallic strip. In this two thin strips of metal are bonded together. As the temperature changes, one expands or contracts faster than the other. Since the two strips are bonded, the result is that the strip is warped, it bends. As it does, an electrical contact is made or broken.

For example, as the temperature rises inside your home, the metals of the bimetallic strip expand — one faster than the other. The strip bends and makes

# 10/TR

## Troubleshooting

10/TR - Th

Thermostats

contact. This trips a relay which in turn starts the compressor of the air conditioner. As the temperature lowers, the metals contract. Eventually the strip snaps back and away from the contact, and the air conditioner shuts off.

For appliances that provide heat, the action is usually reversed. That is, instead of being normally open and making contact, the heating-type thermostat is normally closed, breaking contact (and stopping current flow) when the desired temperature is reached.

### Heat Coil Thermostat

Somewhat similar is the heat coil thermostat. Instead of being in a strip, the metal is in a coil. With increased heat, the metal expands and the coil presses outwards. Quite often this outward expansion is used to physically move a switch. One common example is the mercury switch. The mercury is inside a small tube. As the tube is tilted, the mercury slides from one end to the other which makes or breaks electrical contact.

### Thermistor/ Varistor

A variation on the thermostat are the thermistor and varistor. Both are electronic solid-state devices and both are sensitive to changes in temperature and voltage. For heat sensing, as the temperature changes, so does the internal resistance of the device. This in turn is used to control the flow of current. Exactly how depends on the unit involved. It's even possible for the heat sensing device to be built into an IC (rather than being separate from it).

### Thermocouple Device

Still another option is to use a thermocouple device. In this case, heat applied to the thermocouple generates a small electrical current. This current can be used to active a relay, to trigger an IC or other circuit.

### Heat Sensing

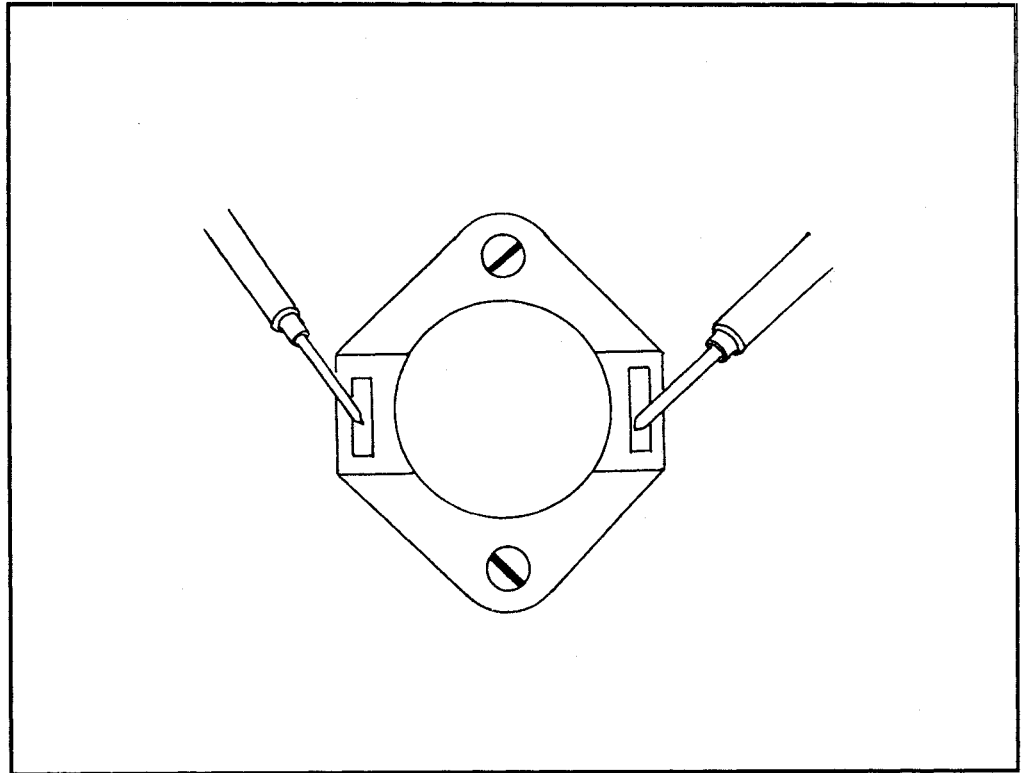
Some thermostats are preset. That is, they are made to work at a predetermined temperature. Many warming plates and most coffee makers are like this. Other thermostats can be adjusted so that the operator can select the temperature at which the thermostat triggers the circuit(s).

However the method of the heat sensing, and however this is used to control the appliance, the thermostat device acts like an automatic switch. It is tested as a switch.

### Testing

The first step is to determine if the thermostat is normally closed or normally open. This can be easily deduced by what the thermostat is supposed to control. In most cases, the thermostat will allow the flow of current until a determined temperature is reached. This is the case in virtually everything that is meant to supply heat. Again, such a thermostat is normally closed. The contacts touch and allow current flow until the set temperature is reached. Contact is then broken, and current flow stops.





**Figure 2:** Testing a thermostat

To test a standard thermostat the DMM should read almost  $0 \Omega$  when the appliance is off, and infinite resistance when the appliance reaches the set temperature. The opposite is true with the normally open thermostat. In this case, the reading will be infinite normally, and near zero at the set temperature.

**10/TR**  
Troubleshooting

10/TR - Th

Thermostats

# Section 11

# Miscellaneous Devices

---

## Table of Contents

11/A	<i>An Introduction</i>
11/C	<i>Copier</i>
11/C - A	<i>An Introduction</i>
11/C - TR	<i>Troubleshooting and Repair</i>
11/F	<i>Fax Machine</i>
11/F - A	<i>An Introduction</i>
11/F - M	<i>Maintenance</i>
11/Tel	<i>Telephone</i>
11/Tel - A	<i>An Introduction</i>
11/Tel - TE	<i>Test Equipment</i>
11/Tel - TR	<i>Troubleshooting and Repair</i>
11/Tel - TR - CP	<i>Cordless Phones</i>
11/Tel - TR - SP	<i>Standard Phones</i>
11/Tel - TR - TL	<i>Telephone Line</i>

Table of  
Contents

---

---

---

---

## **11/A**

### **An Introduction**

---

As this manual was being planned and assembled we quickly realized that many devices fit into more than one section, while others didn't quite fit anywhere.

Since our goal is to be of maximum value to you, both now and in the future, we created this "miscellaneous" section. This allows for an open-end structure to the manual. This section is reserved for items:

- that don't fit elsewhere
- that involve new technology not applicable elsewhere
- which are relatively rare
- which are difficult to fix because of a lack of information from manufacturers, but which deserve coverage.

Concentration in this base manual will be on various business machines like FAX machines, copiers, telephones, etc. Other items of interest will be added in future supplements. As always, we welcome your input. In this particular case, we especially invite any technical information you can share concerning items about which data is difficult or impossible to obtain. (This does not mean "trade secrets", but simply the solid technical data needed by the technician in the field to diagnose and repair malfunctions.)

**11/A**  
An Introduction

---

11/A

---

An Introduction

---

---

## 11/C - A

### An Introduction

---

Copiers, fax machines and laser printers all have one thing in common: they convert images to print by means of a drum and toner (and perhaps developer) system. Copiers and fax machines must convert an image to a digital representation and then return that image to print like the original. Laser printers merely take digital information from a computer and arrange it in a printable format. (Many newer PC-based fax machines do this as well).

Copiers are perhaps the most difficult item to get service literature on. Copier distributors and manufacturers are unlikely to be of help when requesting service information.

First, copier manufacturers do not wish to be liable for any injury that may incur to the untrained technician working on their machine. These machines have many areas across the drum and fusing elements that have very high voltages. The untrained person risks great danger.

#### Warning

*In fact, this information is given to you both for your own safety, and as our own disclaimer. Working on a copier can be extremely dangerous. You do so at your own risk.*

Second, copier information and design is proprietary information. Only a qualified (through factory authorized training) individual may be permitted to work on these items. These people are usually also the only ones who have access to replacement parts.

To become a factory authorized repair person requires being trained at one of their service centers and/or working for their company. Some copier manufacturers offer a general, broad-based copier training course that the general technician may take for a fee. This course can give the general technician the required background to do enough repair work on copiers for the most common repairs. The course includes generic diagrams and schematics to aid in the understanding of copier functions. This can then relieve them of some of the liability for any individuals injured.

The more detailed training requires that the technician go to work for the company. Generally he or she must sign a "secrecy" form, and promise to not reveal any of the proprietary information.

### Copier Basics

In preface, it was mentioned above that copiers transpose the original image into digital format. This is true only in the most technical use of the word “digital.” The image on the drum is created, and held, electro-statically, which means that it uses positive and negative charges. This is the + and -, or the 1 and 0. Do not confuse this with digital technology, but keep the information in mind as it will help you to understand the similarities, and differences, between machines such as copiers and laser printers. These two share certain technologies, just as laser printers and fax machines share certain technologies.

A copy machine takes a “picture” of supplied image, converts that image to a “charged” data image that is transferred to a specially coated drum which is pressed against a piece of paper. The image is then fused to the paper and sent out.

### Drum

The drum is a photosensitive device that actually has the mirror image of the original attached (electro-statically) to its surface. These particles are composed of a powder called the toner which is normally black, but could be produced in a wide variety of colors.

### Digital Keyboard

All copiers will have some kind of digital keyboard which allows you to input various information about the copy you are trying to make. This information includes how many copies of the original you wish to make, the size of the copy and the contrast level of the copy.

There will be various indicator lights, either on the keyboard panel or status lights located inside the front cover of the copier. These status indicators may be icon based to indicate the particular mode of operation (copying, reducing, error type) to indicators that turn on next to a list of functions.

### Paper Input

There will be at least one input for copier paper and one exit point for the finished copy. The paper to be copied onto may either be hand fed (Canon PC-3 copier) or tray fed (Xerox 1040) copier. Some copiers (Ricoh FT6200) have the ability to have two trays with varying sizes of paper (one for 8.5x11 inch and the other for 11x14 inch paper). Professional copiers can handle multiple trays for paper storage, with multiple trays for output which allow for collated copying. Some machines can even staple a finished section together. In addition, some allow the paper to be printed on both sides (for copying double-sided original material).

The original (the item being copied) is placed on the glass document surface with the side to be copied down (toward the glass). The copier then either moves the document glass over a very bright bar light and light reflectance reader, or passes a light bar across the paper with a lens picking up the image. Either way, the image is sent to the drum for printing.



Basic copiers require each original to be placed manually. Many larger machines allow for many originals to be placed in an auto-feed system that either uses a vacuum or various rubber wheels to pull the paper through the copier.

The contrast level control will adjust the difference between the light and dark portions of the image. If there are lines that are very light, or drawn in various colors, the contrast level may need to be set higher so the copier can reproduce the image. The result is sometimes an over-blackening or smudging of other portions. Similarly, if the darker portions are set for more accurate reproduction, the smaller, lighter lines may disappear.

## Paper

Paper made for copiers is different from standard bond paper. Copier paper is thinner and is also more slick. These characteristics help it to move through the copier more easily and help to reduce the amount of paper dust left behind. Except for older copiers, you can successfully substitute bond paper. Copiers designed to handle bond paper are often referred to as “plain paper” copiers. These are becoming more and more popular. You can select the kind of paper on which the copy will be made. Making copies of a resume on the slick-type copy paper is much less appropriate than having it copied onto a nice cotton bond paper. Or a copy may require the use of a pre-printed letterhead.

To reduce the amount of dust that gets into the copier, and thus reduce both the maintenance and malfunctions, paper should always be stored properly. This begins by keeping the paper dry and away from contaminants.

It's important to keep the paper dry, but this simply means that it shouldn't have excess moisture. Heat can cause the paper to become too dry. This will allow it to pick up too much electrostatic charge. Under the best of circumstances the paper can pick up a charge from the drum, causing the sheets to stick together. If the paper is overly dry this tendency increases.

You must also be sure that it isn't damaged. Paper that is curled or is in some other way bent, kinked or folded will most certainly result in a jammed copier and poor image reproduction.

The paper should be on a flat surface. Although it's okay to stack reams of paper, never lay any heavy objects on the paper. This can cause bends and creases in the paper which can later make the paper useless for the copier.

## Toner

For a copier to produce an image, it needs a powdered chemical called toner. This product is continuously replaced with each copy made. Unused toner is never returned to the original container. Once toner has been in contact with the drum or any other surface in the copier it is considered spent and cannot be used again.

Toner is a heat-sensitive chemical. It is fused to the paper by means of heating elements and rollers which literally press the toner to the paper and melt it into the paper fibers. (Feel the paper coming out of the copier. It will be warm.)

Only factory authorized toners should be used in copiers. A poor example of this is where a customer was using toners created by a third party for his Xerox 1040 copier that was "supposed" to be as good as the real thing. After using the product for a short time, the machine began to malfunction. He had to call (and pay for) the Xerox service technician to repair his machine. He was told the product being used was not a proper mix for the particular machine and that the drum, toner and developer (for this machine) would need to be replaced. The little he saved ended up costing him hundreds of dollars.

Wherever you purchase your toner, be sure to store it in a cool, dry, dark place. When loading the new cartridge, take care. It's all too easy to have the powder fall out.

If it does fall out, gently sweep it up. Do not try to wash it up with a wet rag, especially if it has fallen onto carpet. When it is wet, it has a greater tendency to smear.

### **Developers**

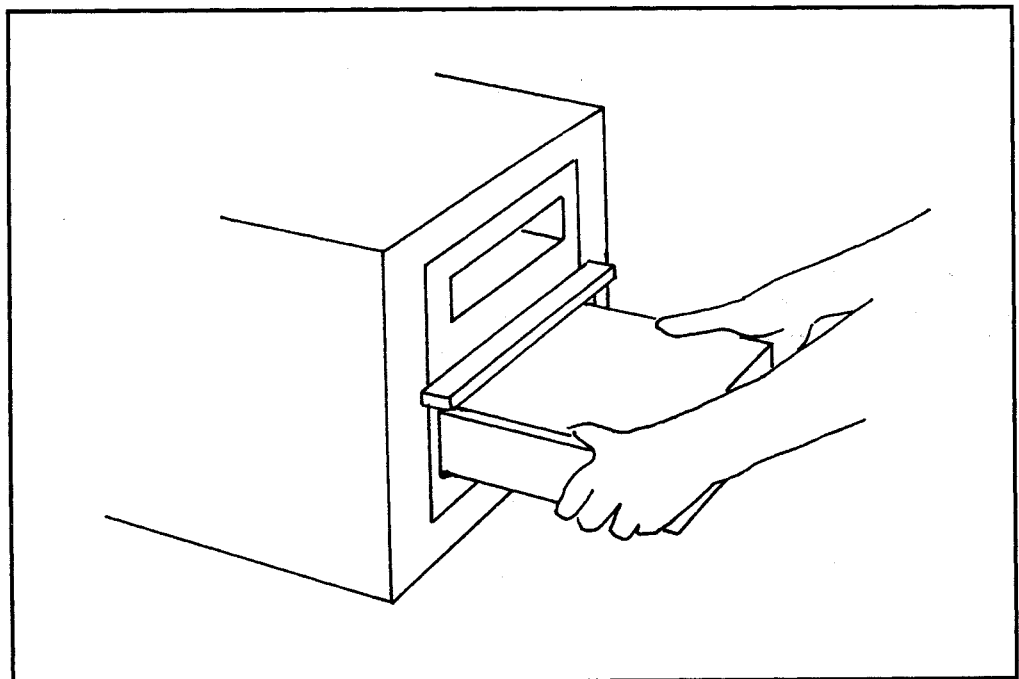
Developers are used in some copy machines in conjunction with toner to produce an image on paper. The developer and toner work together in a similar fashion to the way developer and fixer work in printing pictures. One cannot work without the other in copiers requiring a developer.

Developers are replaced less frequently than toners. They are replaced when the drum is to be replaced, which means that the owner usually doesn't have to worry about it. If it is used, the developer must be stored in the same manner and conditions that paper and toner are stored.

**11/C**  
**Copier****11/C - TR**  
**Troubleshooting and Repair****Misfed Paper**

Paper for copiers is fed through a series of friction wheels (pinch rollers) and fuser rollers in a twisting, curving path before exiting a copier. On occasions, paper will become jammed in the copying process. When this occurs, various sensors located throughout the travel path sense the papers location. If the paper does not pass these sensors in a prescribed time, the copier alerts the user and shuts down the copying process.

Most often the paper misfeed will be found at the entry point. A part of the reason is that sometimes a “misfeed” signal will result from an empty paper tray, or from a tray in which too much paper has been loaded. In either case, the paper problem will need to be fixed.



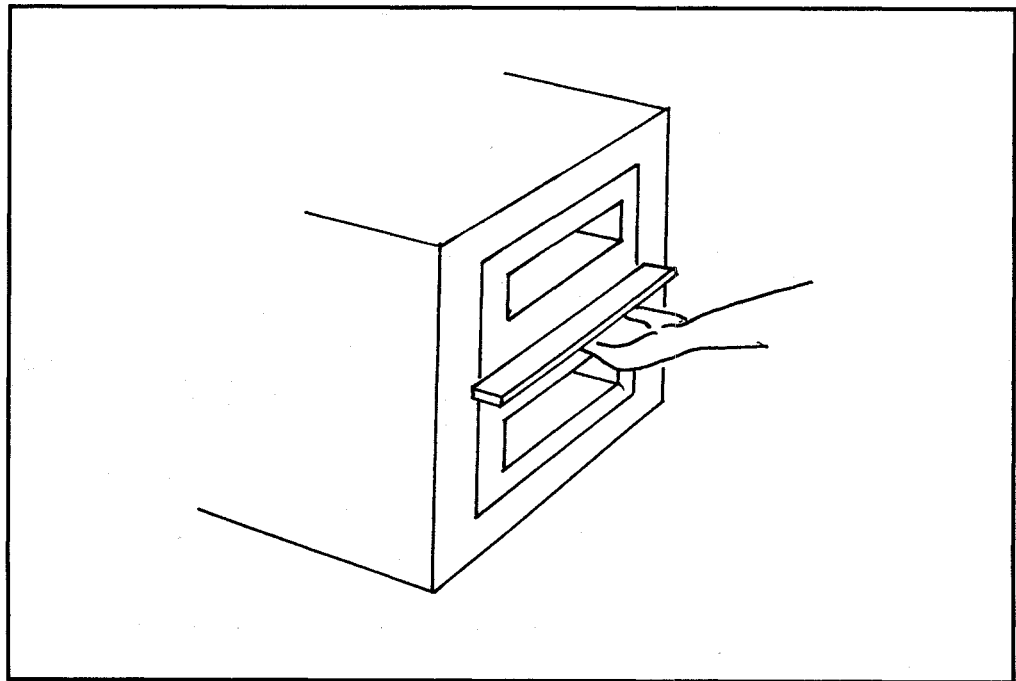
**Figure 1:** Before suspecting the copier, inspect the paper tray.

Remove the tray and ensure there is paper present. Next see if there is any paper protruding from the copier. If there is, remove the paper and replace the tray. The front cover on many machines will need to be removed to reset the copier sensors so copies can continue to be made.

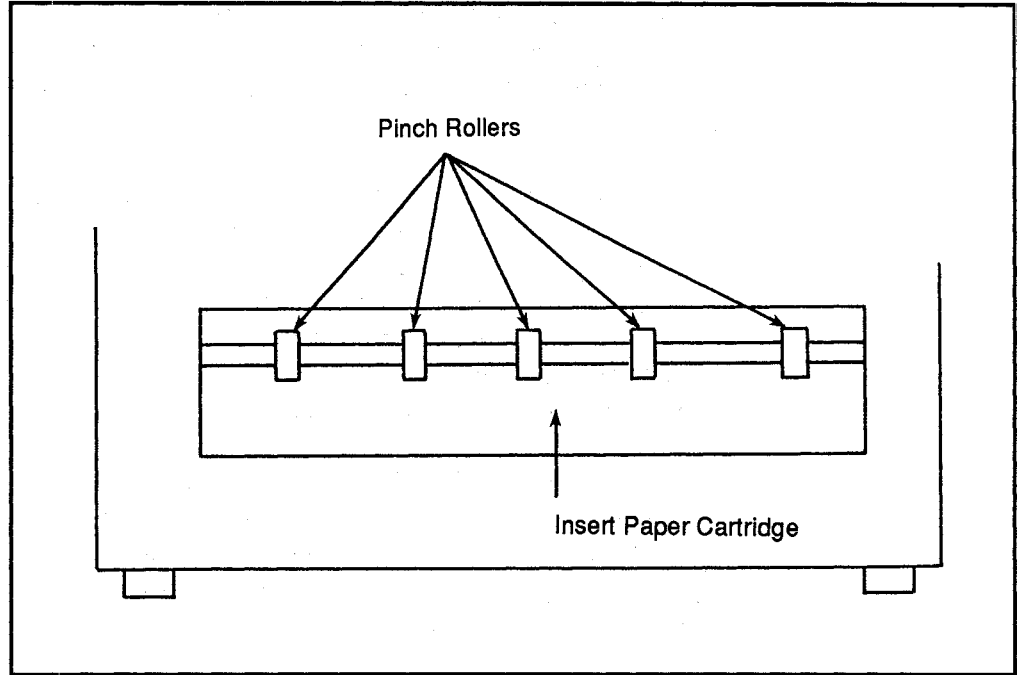
If the problem was not found at the paper cassette entrance, the misfeed might be found within the copier. Most copiers will have a handle that is lifted or pulled to remove the fusing section and travel path for the copier. Do so and check the travel path for any paper, or paper pieces. Be careful when touching any part of the fusing section. This area generates a large amount of heat and current, needed to fuse the paper before exiting. Also, touching the drum and some other parts with your fingers can cause damage.

On larger copiers (Ricoh FT 6200, for example) the paper travel path is longer than a smaller copier (like the Canon PC-1). The front cover will need to be opened and the turn guide unit removed. This will be seen (in the FT 6200) as a bright orange square with a large handle attached. Pull it out and remove any paper found in the turn guide section.

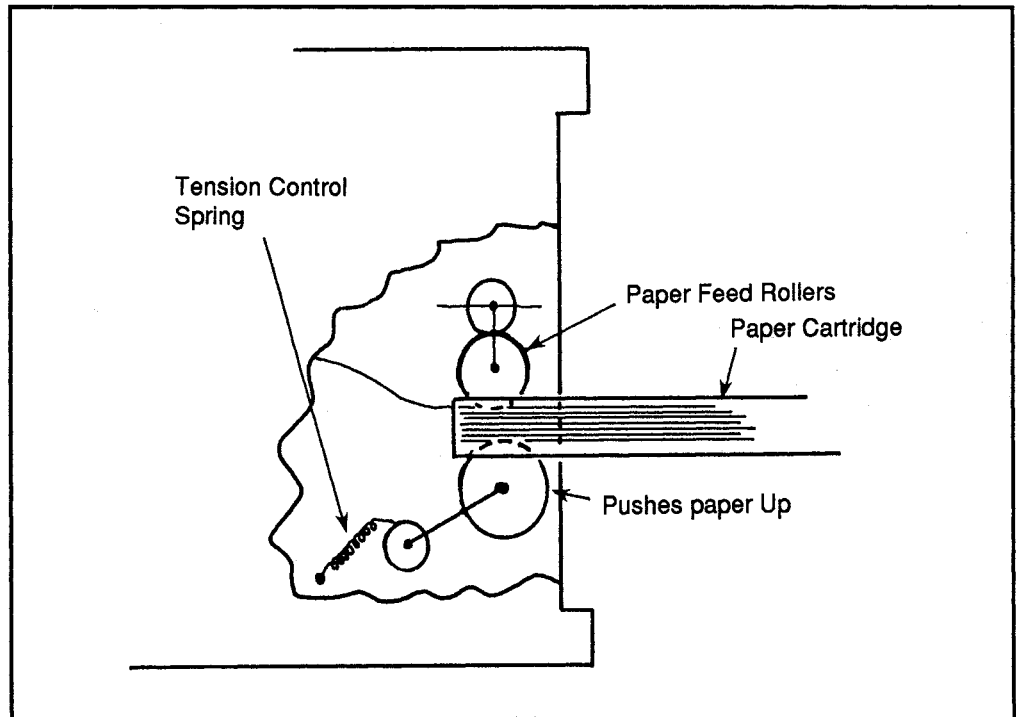
Larger copiers may have reset buttons that need to be pressed before the unit will allow any further copying. On smaller copiers (Canon PC-1, Xerox 1040, Sharp



**Figure 2:** Access to the paper path



**Figure 3:** Inspect the copier pinch rollers for wear.



**Figure 4:** Tension control adjustment

76, etc.) the reset happens when the front cover is opened and closed, or when the fusing section is replaced.

Frequent misfeeds can be the sign that there are more advanced problems. Paper that continuously jams at the tray may mean that the paper is bad, that the pinch rollers that grab the paper are bad, or that the tension for the pinch rollers is not set properly. In any event, try replacing the paper with a fresh batch before tearing the unit apart, or calling a service repair-person.

If the misfeeds continue, first suspect there is a problem with the pinch rollers. These rollers grab a single sheet of paper and pull it into the machine. If they become worn or broken they cannot properly grab the paper. In either case they will need to be replaced. Order new parts from the local authorized dealer.

If the tension control is set wrong, the paper may not be grasped properly and can cause misfeed. This will usually be indicated by the paper not leaving the tray and a slipping sound when the copier tries to pull a sheet of paper out of the tray. Most of these tension controls are spring controlled. Adjusting the tension of the spring can control the grasping power of the pinch rollers. Too much tension, however, can cause more than one sheet of paper to be fed into the machine or cause some other form of jamming to occur. Adjustment must be made carefully and a little at a time. Adjust until paper is fed correctly.

### **Printing Does Not Occur**

Most copiers require a warm up period. Trying to make copies before the machine is ready will give poor results at best. Chances are, the machine won't work at all. (Most will have a "Ready" light to indicate when the copier has completed the warm-up.)

There will be indications that this is happening. Lights may come on (including a "Wait" light). You will usually hear sounds from inside.

If nothing at all happens, begin with the most obvious. Is the unit plugged in? Has it been turned on? Look for status lights. If there are any, the unit is at least plugged in. It's possible that the unit is getting enough power to drive the lights and nothing else, but this is unlikely.

Accessing the power supply section may be difficult. If it's possible to get inside, you can perform the usual visual checks to see if any fuses are blown, and the usual DMM checks to find if power is actually getting to the unit, if power is coming out of the supply, etc.

Quite often the status lights will give you a good indication of which area is not

working properly. These indicators may be in the form of lights alongside words, LED-type words or as icons. For example, if the copier is out of paper you may see a light come on next to “Paper Out,” you might see those words light up on the status panel, or you might see an icon that represents sheets of paper.

In the case of icons, it’s not always obvious what they mean. You may have to turn to the copier manual.

One of the most common “errors” that will prevent printing is the “Paper Out” indication, with “Add Toner” being a close second. Most of the time the indicator means just what it says. You have only to fill the paper tray or replace the toner cartridge to fix the problem. (Note that you will probably have to wait through the warm-up period again.)

Other times the indicator can mean something more serious. For example, if the “Paper Out” indicator comes on yet there is paper in the tray, for some reason it is not feeding into the machine. (See “Misfed Paper” above.) A visual inspection will probably show you where the problem lies.

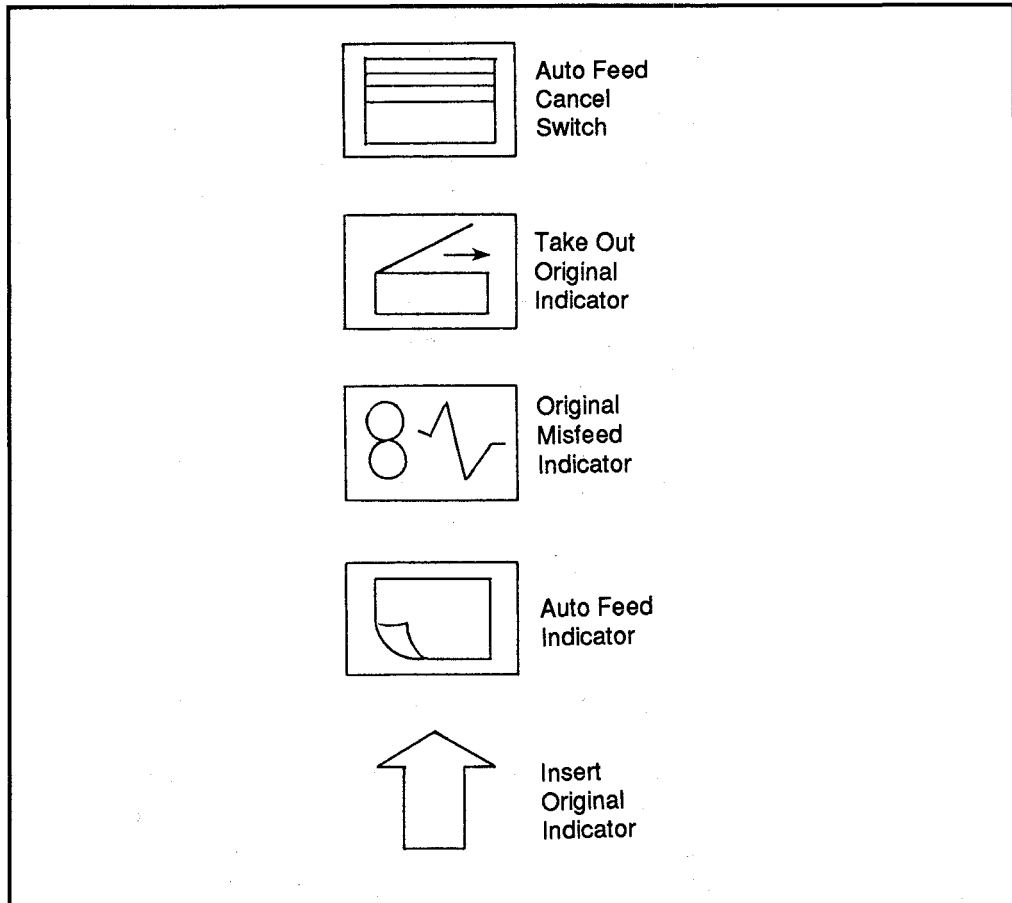
“Check Paper Path” indicates that there is a piece of paper stuck somewhere within the unit. This icon may look like a number “8” with a “Z” on its side. Locate the kammed paper, remove it and try again. If the problem occurs again, try a fresh batch of paper (preferably from a new ream). If it still happens, it’s mostly likely that something in the paper path is causing the paper to jam. This could be anything from some physical obstruction (which includes general dirtiness), worn or damaged rollers or a paper that has caught in the exit.

If Service indicator lights (a common icon for this is a picture of a little mechanic) you will need to call the customer service representative. This indicator tells that something more serious has happened. If a visual examination doesn’t reveal the cause, there is little that can be done without the service manual for the machine.

### Poor Copies

Poor copies can occur from a variety of problems. The most obvious is that the original may not be as clean as required, or is so thin that light is passing through the item if the cover is not closed when copying. (The copier cover offers a 100% white background for originals when being copied and should be used whenever possible.)

The next most common problem is a dirty platen cover or exposure glass. This could be due to visible stains or less visible smudge marks from fingers and hands. The glass surface must be kept clean to ensure proper copying. Clean the glass with a soft rag and glass cleaner. Both sides of the glass may need to be



**Figure 5:** Some common copier icons

cleaned, especially in those copiers that the document glass moves to make copies. The document glass can usually be slide far enough in both directions to allow the cleaning of more than half of the glass.

Some copiers (like the Xerox 1040) have a release catch found behind the front panel at the top right. Moving this catch allows the document glass to slide further than normal in one direction or the other for cleaning.

In some copiers, there may be a number of small long rectangular windows through which the light must pass before the final copy is made. These can be found after opening the front cover. Each of these windows can be removed from the copier for cleaning. Refer to the operating instructions for the placement of these windows (if present) for your particular copier.



Another common cause of poor copies is a poorly set exposure level setting. This can cause the copies to be too light, too dark or even muddy in appearance.

On the control panel can be found a selection that may allow automatic exposure and/or manual settings. If poor copies occur with the automatic exposure set, try setting the exposure to manual and choose an appropriate level. This may require some experimentation.

Streaking or lines within the copy can be caused by dirty travel paths, old toner/developer, or a drum that is beginning to fail. Clean the travel path first, then try making a copy again.

Next, inspect the drum for any lines or marks that should not be present. A new drum should be shiny, very reflective (almost like a mirror), and very smooth. If there is stray toner on the drum, it can be wiped off with a good optical chamois or other very soft cloth.

If the drum appears to be OK, replace the toner and/or developer. Run several copies through the machine to see if the problem has been fixed. If not, the drum is probably bad and will need to be replaced.

The problem of poor copies could be caused by sections of the copier (other than already mentioned) that may not have been suspected before. Copies that come out of the copier smeared, or with the toner falling off indicate that the fuser section is not operating properly. One of the heating elements is probably burned out.

Each of the fuser heating elements may need to be pulled and checked. How this is done depends on the specific make and model but the method of removing them is usually fairly obvious. Bear in mind that there is a potentially very high current in this area. It's best to unplug the copier before attempting any work in this area.

The fuser heating elements will usually be light rods that are the width of the fuser section. Each rod may appear as a series of small bulbs, or as one continuous quartz crystal bulb.

The easiest method for testing is to use a DMM and do a continuity check on the element. The reading is not important. Your goal is simply to find if there is a reading at all. Resistance should be low across the element.

The greatest problem you will have is that even if you test and find that the

element is bad, finding a replacement will be difficult and sometimes impossible. You may have no choice but to call an authorized service technician to make the replacement even though you've diagnosed the problem and can easily cure it on your own.

### Contrast and Background Adjustments

It is possible, over time, that the adjustment for the contrast and background have changed. Usually there will be at least a contrast adjustment other than the control panel that can be set for the normal contrast level.

On the Xerox 1040, there is a background adjustment and a contrast adjustment. These are located inside the front cover on the copier frame. Here you will find a hole with a plastic flat-head screw adjustment. This is the contrast adjustment. By adjusting the control in one direction or the other you can lighten or darken the copier contrast range. Turn the control in small steps and check copies. If the background appears too muddy, but the foreground is at the level you like, you can adjust the background adjustment. This adjustment will lower, or increase the overall level of black in the copy, and a balance between the contrast and background adjustments should be met.

Behind the left fold down panel (as you look at the copier from the front) is the

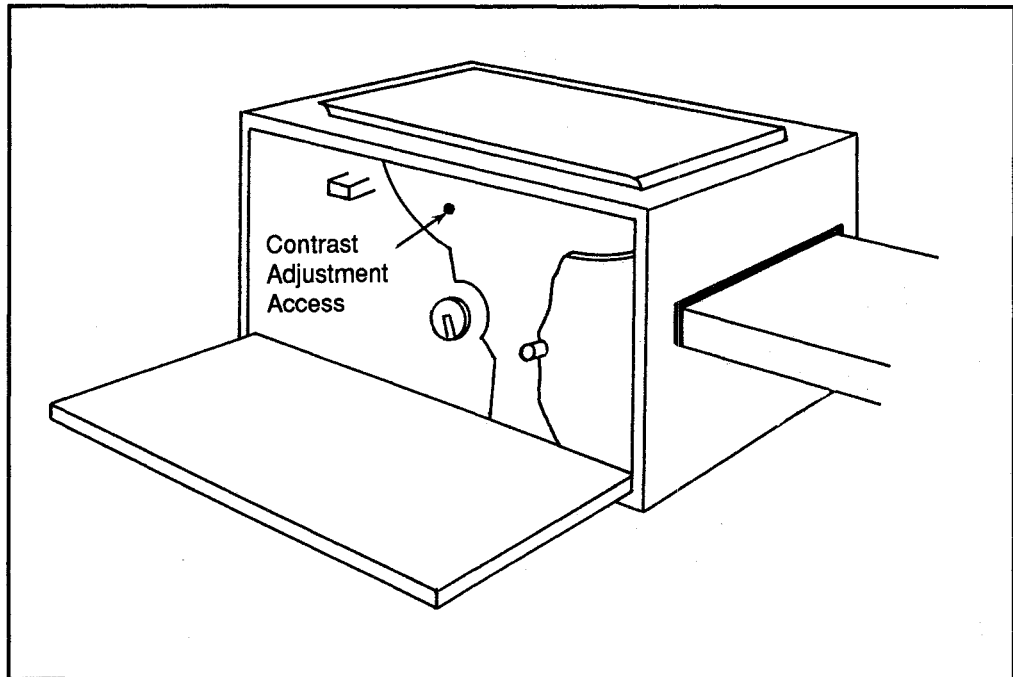
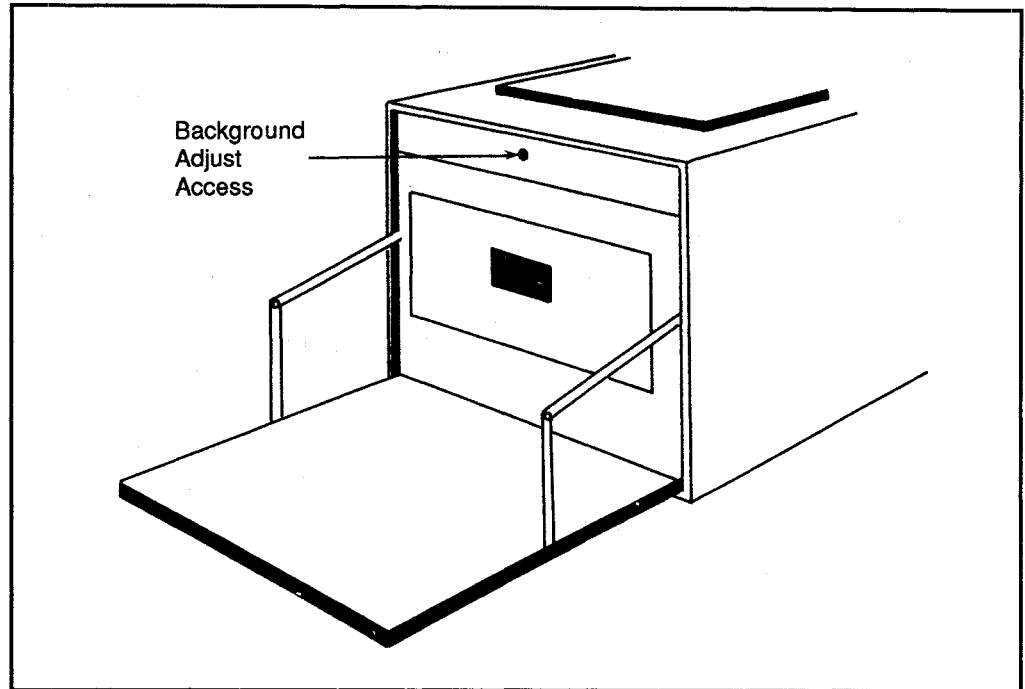


Figure 6: Contrast adjust on a Xerox 1040



**Figure 7:** Background adjust

developer loading section. At the top, and near the center will be a small round opening. A small jeweler's screwdriver can be used to access the adjustment here and change the background level. Adjust in small increments in either direction to change the background level. You may have to bounce back and forth between this adjustment and the contrast adjustment to get copies that meet your needs.

### Miscellaneous Problems

Various other problems may occur within the copier. If copies always exit the copier as a black sheet, it can be assumed that the main element has gone bad, or that there is a major misadjustment of the contrast and background controls.

Toner can become abundantly scattered throughout the copier and cause the performance of the unit to drop. The copier should be periodically cleaned with a sweeper to remove any miscellaneous toner deposits. Again, using a wet rag or dry rag to wipe up toner may not work and will usually grind the toner into the surface being cleaned or make a bigger mess.

### Warning

*Always shut off and unplug the unit before cleaning! Any work on the copier without the service manual is a major risk. Voltages within a copier can exceed 600 volts at some points. Not all of these are obvious. Not knowing what is safe*

*to touch and what is not can be hazardous. If service literature cannot be obtained, either because the information is proprietary or for some other reason, let a qualified service technician handle the work.*

As has been mentioned, quite often it is irrelevant if you can safely find the cause of the trouble or not. If replacement parts aren't available, troubleshooting the copier won't be of much help.

**11/F**  
**Fax Machine**

11/F - A

An Introduction

**11/F**  
**Fax Machines**

**11/F - A**  
**An Introduction**

Facsimile machines, or fax machines as they are referred to today, are considered by most as being a relatively new invention. This is true only concerning the exact technology now being used.

**Facsimile  
Machines**

Facsimile machines have been in existence since the advent of the telegraph, and in a more limited way since before this. These early machines were able to systematically punch paper from a fed Morse code that was sent over the wire. The images were crude, but it was the forerunner of modern fax.

Most advancements for facsimile machines came from the needs of businesses, media and police departments who were looking for methods to send pictures across a wire to help speed the information gathering/sharing process. Many of these early systems would have a rotating drum to which a picture was attached. The drum would rotate and the image would be scanned. Each light and dark portion (or variations thereof) were scanned and then transmitted across the telephone and reproduced in a similar fashion at the other end. Over time, advances in technology have led to the invention of the modern, digital facsimile machine.

**Fax Transmission**

Fax transmissions are rapidly overtaking even overnight mail as the most rapid method for sending printed material. Fax machines can be either stand-alone machines or the less expensive computer-based circuit boards.

In a stand-alone fax machine, the document or other image to be transmitted is inserted. An array of photodiodes scan the image in a manner similar to that of a laser printer. The image is digitally converted into the thousands of dots required to represent the image. The binary pulses are sent over the phone line and are then reconverted to an image (again in a fashion similar to that which a laser printer uses to create an image).

**Elements**

Most stand-alone fax machines contain three elements:

**11/F**  
**Fax Machine**

11/F - A

An Introduction

- the scanner
- the modem
- the printer

**Scanning Process** The scanner scans an image on paper and converts the information to digital data. Simple fax machines merely decide if the portion being scanned is a black or a white and transmits this. More advanced machines can decipher different levels of gray to create pictures that do not have to be “line art only” (text or simple lines). Typically these will range from as few as 16 gray levels to 256 gray levels. The higher the number of levels possible defines the clarity available to recreate a faxed image.

**Internal Modem** Regardless, the scanned data is transmitted via the fax machine’s internal modem. This modem modulates the digital information and sends it over the telephone. The telephone network is an analog device, so the information must be modulated (converted from digital to analog).

The receiving modem does the opposite by demodulating and then reassembling the information into digital information. The text/image can then be printed.

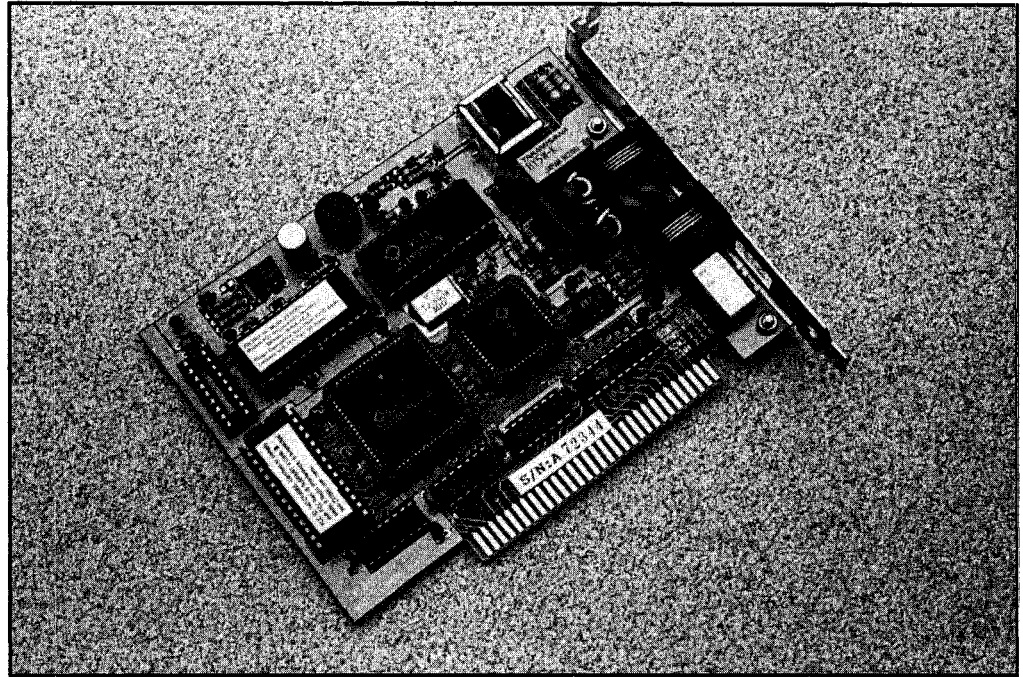
**Printer Section** The printer section of the fax is similar to that of a laser printer. The image is created in the fax memory, to be transferred to paper via a rotating drum. The paper is then output as a completed fax image.

**PC-based Fax** The PC-based fax unit is a plug-in circuit board that makes use of the computer system’s power and devices. It is considerably less expensive because of this. For example, printing of the faxed image is handled by the printer already connected to the computer.

The basic operation is the same. The fax card takes digital information from the PC, converts it to data that can be transmitted over the phone line, and modulates it for transmission. In the receive mode, the incoming data is demodulated, converted into the digital computer language and can then be sent to the printer.

There are some major differences. The PC-based fax card relies on the computer and its connected devices. Since the computer is also used for other purposes besides fax transmission, special software must be loaded for the fax card to operate.

The stand-alone fax unit works with pre-printed material while the PC-based fax unit deals with material already on computer disk. Unless a separate scanning



**Figure 1:** Fax circuit board

device is attached to the computer, a PC-based fax unit does not and cannot send pre-printed material. (It can, however, receive such material and will reproduce the image if the attached printer is capable of printing it.) In other words, the PC-based fax cannot take a sheet of paper and transmit it directly. The page would have to be scanned and converted first.

In essence, the PC-based fax unit is less expensive because it consists only of the center function of a stand-alone unit. It doesn't scan or print by itself. In virtually every case, the circuit board will be a combination of modem and fax.

Someone purchasing a modem circuit board (card) can spend just a little more (usually less than \$50) and have fax capability.

**11/F**  
**Fax Machine**

---

11/F - A

---

An Introduction

---

---



**11/F**  
**Fax Machine**

---

11/F - M

---

Maintenance

---

**11/F**  
**Fax Machines**

---

**11/F - M**  
**Maintenance**

---

With prices going down, and manufacturers becoming more and more reluctant to release any technical data, fax devices are going the way of the transistor radio. This unfortunate tendency is that it's often less trouble and cost to replace the unit than to attempt a repair. Once again, even if you manage to troubleshoot the unit, replacement parts are unlikely to be available. This often makes even the effort to bring about anything but the most basic repair a waste of time. If you track the problem to a specific component but cannot get a replacement for that component, you've gained nothing but the knowledge of what failed.

Fax machines are being made by more than forty different manufacturers. Most of these fax machines are created by the same people that create copiers and laser printers. Unfortunately, this means once again that service data and replacement parts are extremely limited because of the manufacturer's stand concerning what they consider to be proprietary information.

**Internal Problems**

If the fax develops an internal problem, there is little you, as a general technician, can do. Repairs will have to be done by an authorized service center. There are, however, some basic precautions that can be done to avoid the risk of damage to the fax machine.

Fax machines should be located on a stable surface free from vibration. The unit should always be used on a level surface.

Dirt and moisture should be kept from the fax machine. Keep liquids away from the fax. In addition, don't place the fax unit near a humidifier or even an open window.

The fax machine is sensitive to temperatures outside the 41° to 95° F range. Therefore, the fax machine should be kept in an area with no extreme temperature fluctuations.

**11/F**  
**Fax Machine**

11/F - M

Maintenance

**Original Documents**

Original documents affect not only the quality of the images copied and/or transmitted, but also the condition of the fax machine. Documents must be clean and dry. Excessive dirt or moisture on the original as it is fed into the fax machine can cause a build up on the paper-feed rollers. This is guaranteed to eventually cause problems such as paper jams and perhaps complete unit failure.

Each original should be inspected to ensure there is no kind of wet ink, paste, liquids, or correction fluid that can chip or flake. There should be no staples, paper clips or tape, any of which can come loose or otherwise damage the fax unit. When in doubt, make a clean copy and use this for faxing.

Even the paper stock of an original must meet certain specifications. Coated or carbon-backed originals should not be used in fax machines. In addition, originals must not be too thick (greater than 0.13 mm) or too thin (less than 0.06 mm). 20-pound paper is best used.

Originals must not be damaged in any way before feeding through a fax machine. If the paper is curled, wrinkled or torn, it could jam the fax machine. This can also lead to a faulty transmission.

Again, in such cases make a copy first and feed the copy through the machine.

**Cleaning**

The fax machine needs to be cleaned on a regular basis. This cleaning is needed both inside and outside to keep the unit in top performance.

Use a soft, nonabrasive cloth. The use of an abrasive cloth could scratch or in some other way damage the unit being cleaned. If a cleaning fluid is used, be sure that it is meant for the job. Residues left behind defeat the purpose of cleaning. Just as bad are those fluids which cause damage. Refer to the fax manual for cleaning solutions allowed.

There may be a document glass where the original is placed when being scanned for transmission. The document glass may be only a narrow strip called a scan glass. Even so, it should be periodically cleaned.

The recording (thermal) head heats up to react with the heat-sensitive recording paper to which images are recorded as information is received. There is no toner in most fax machines, but rather this heat sensitive paper. (Plain paper fax machines use a toner/developer cartridge, in much the same way as a plain paper copier does.) The thermal head should be cleaned every three months, and more often if the machine is used heavily. The various rollers and separation rubber

**11/F**  
**Fax Machine**

---

11/F - M

---

Maintenance

---

---

should also be cleaned every three months. Be sure to use a cleaner safe for rubber parts. Alcohol will dry out those parts and can cause more harm than good. As is so often true, what seems to be a major problem could be nothing more than a filthy machine.

The rollers feed the document into the fax machine. Paper feed rollers advance the recording paper to the printer as well. With normal use, these rollers will collect ink, dust and graphite, all of which can cause image problems like spots or vertical lines to appear in the image and/or cause document jamming to occur. The separation rubber is used to feed the originals into the fax machine one at a time. This area may also accumulate foreign matter, which can cause jamming or the feeding of more than one page at a time.

Section 11 • Miscellaneous Devices

**11/F**  
**Fax Machine**

---

11/F - M

Maintenance

---

---

## 11/Tel Telephone

---

### 11/Tel - A An Introduction

---

The telephone used today is surprisingly similar to the original device created by Bell in 1876. The telephone can be classified into two main categories: the tone dial (touch tone) and the rotary dial (older type) telephones. These may be divided into the single line and the multiline telephones.

With the new electronic phones, many of the primary features, and most new ones, are now handled by microcircuitry. This has brought down the cost of a standard telephone, but has also in many cases made anything but basic repairs all but impossible.

#### **Rotary Phone**

In most cases, a rotary dial phone malfunctions it will be thrown away and replaced with a more modern version. Still, there are times when bringing a rotary phone back into service is desirable. In addition, some electronic phones have a pulse option, making it important to understand how this system of signals works.

There haven't been many changes in rotary phones since the 1950s other than the connectors and look. The mechanical nature of the dial is the source of the most malfunctions. In many cases all that is needed is a good cleaning. By turning current off or on in the local-network cable pair, rotary dialing creates (or pulses) a telephone number. This pulsing in turn causes relays (digitally or mechanically) to be selected at the telephone office which then select the correct line connections to complete a call.

The pulses are created as the finger wheel returns to the rest position. The number of pulses created are determined by how far the wheel is turned. That is, a 1 produces 1 pulse whereas a 0 will produce 10. The rate of pulses is 1 pulse per second with a make-break ratio of 61.5%.

#### **Touch-Tone Phone**

The touch-tone phone is basically the same internally as the rotary phone. The only major difference is the ability to produce tones as specific frequencies via

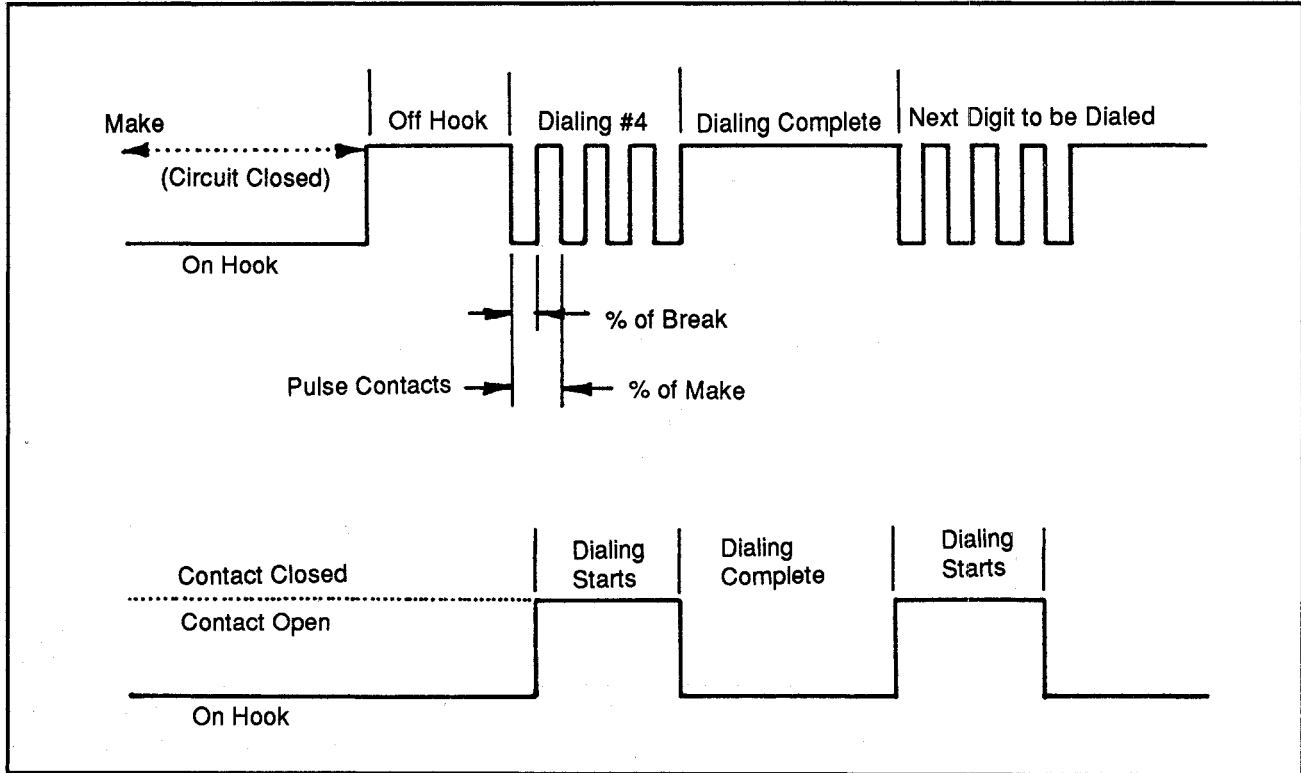
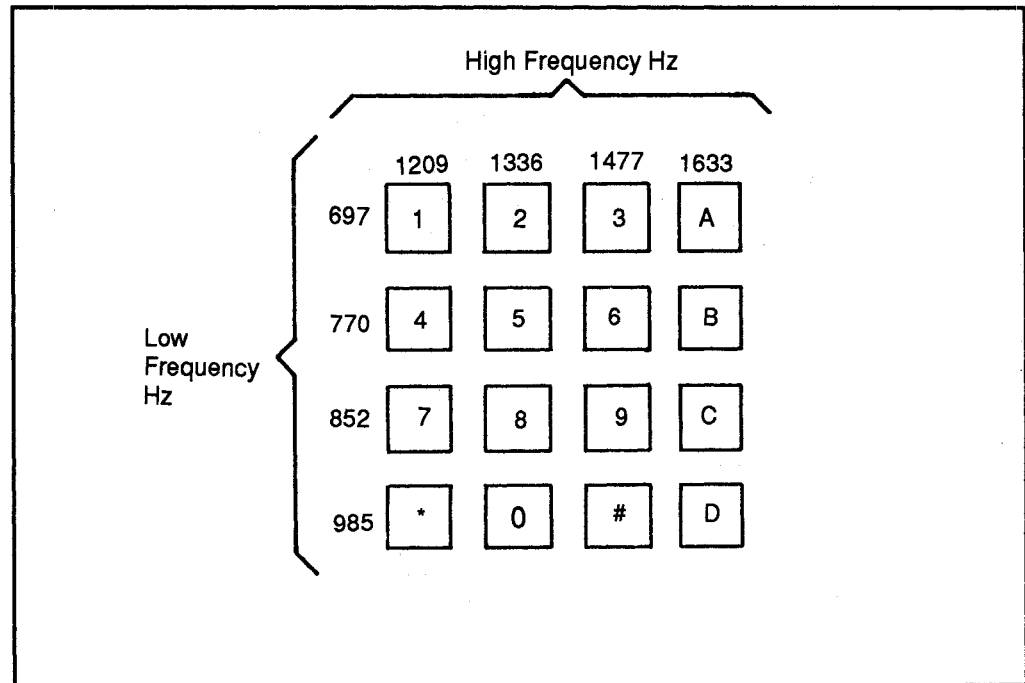


Figure 1: Pulses from a rotary phone

a keypad input instead of the original rotary (pulse) method. The tones from a touch-tone phone are sent out in combination tones known as Dual Tone Modulation Frequencies (DTMFs). Most touch-tone phones are able to “act” like rotary phones when used on a non-tone phone line with a proper switch setting (pulse) on the phone.

Figure 2 shows the frequencies sent by a touch-tone phone as related to the keypad. To generate the base tone for the row or column, press all the buttons for that row or column simultaneously. For example, pressing the 3, 6, 9 and # buttons together would produce a signal at 1477 Hz (or any combination greater than 1 button: 3 and 6, 3 and 9, 9 and 6, etc.). The same would occur for the rows. Pressing a 1 and 2 simultaneously would produce a signal of 697 Hz. These can be viewed on an oscilloscope. When a single number is pressed, the combined tones for the column and row are sent out. For example, pressing the number 5 on the keypad will send the signals 1336 Hz and 770 Hz simultaneously.



**Figure 2:** Touch-tone keypad with related signals

An additional column of buttons and signal not found on most home telephones are the buttons A thru D. This column will produce a signal of 1633 Hz and can be used for special telecom and telephone central office purposes.

### The Handset

The telephone handset is the device which contains the microphone (transmitter) and earpiece (receiver). Handsets may be the same for both touch and rotary phones. Figure 3 shows an exploded view of a typical handset.

### Transmitter

The transmitter transforms the variation in air pressure that result from the movement of sound waves into electrical impulses. Sound waves bombard a thin layer called the diaphragm. The internal workings of a carbon microphone is shown in Figure 4.

By compressing and expanding the reservoir of carbon granules, a resistance that varies in proportion to the applied pressure is created at output points A and B. When an electrical voltage is applied, a current is created. This current is passed through the phone line to a receiver and recreated to produce the original speech pattern.

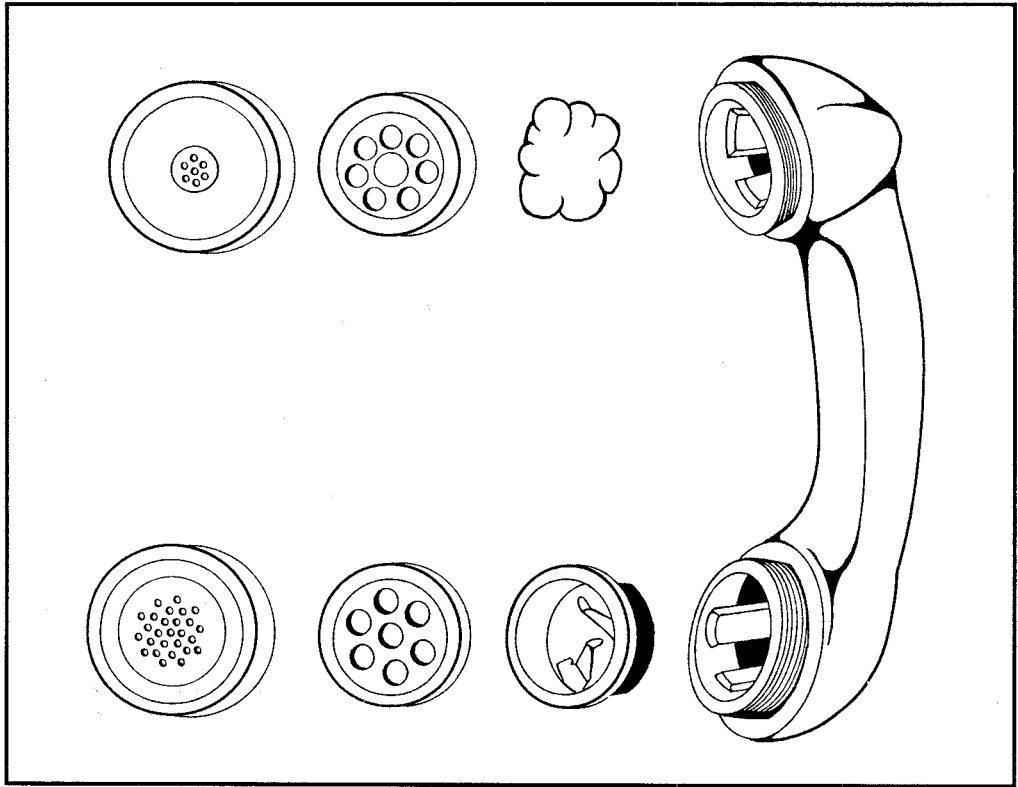


Figure 3: Exploded view of a standard handset

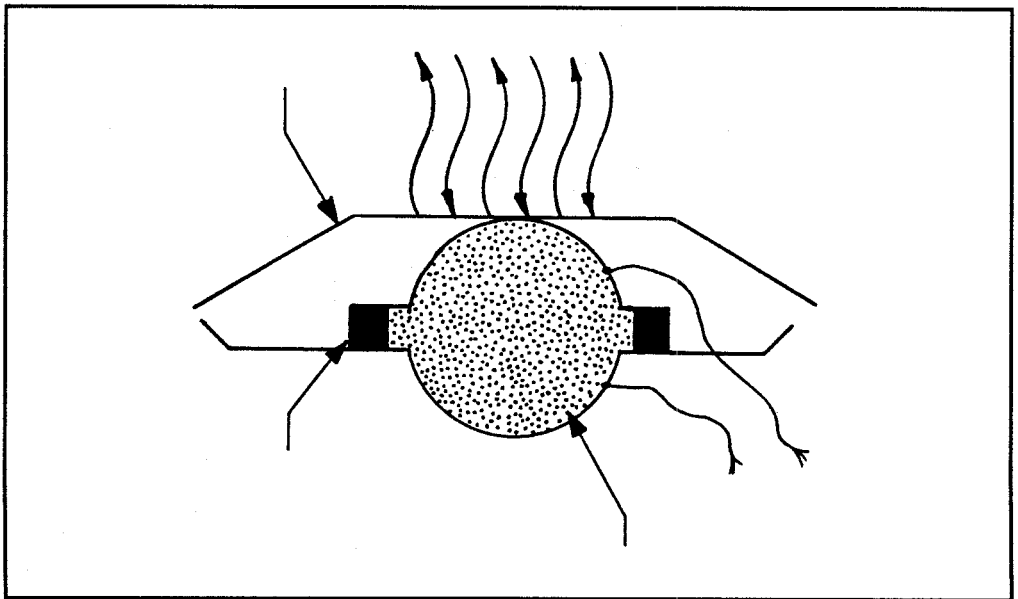
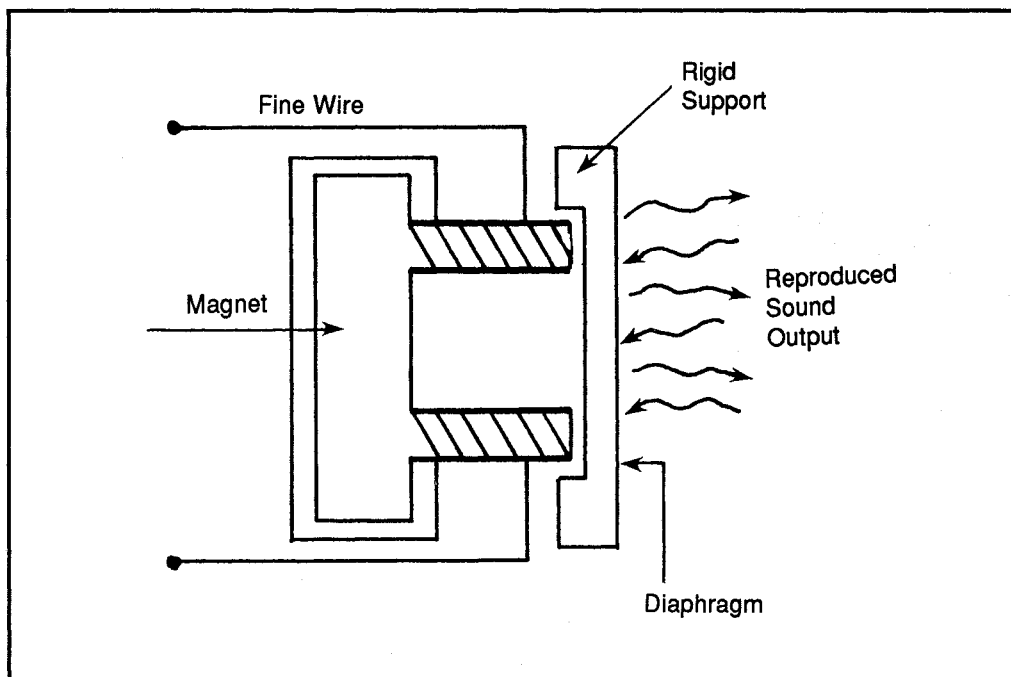


Figure 4: Internal workings of a carbon microphone





**Figure 5:** Internal mechanics of a typical telephone receiver element

### Receiver

Figure 5 shows a typical telephone receiver (earpiece). The receiver changes the varying current generated by the transmitter back into intelligible sound signals. Inside the receiver is a permanently magnetized soft iron core encased by turns of fine wire. The varying electrical pulses received by the wire attracts and repels an iron diaphragm located on the front of the receiver.

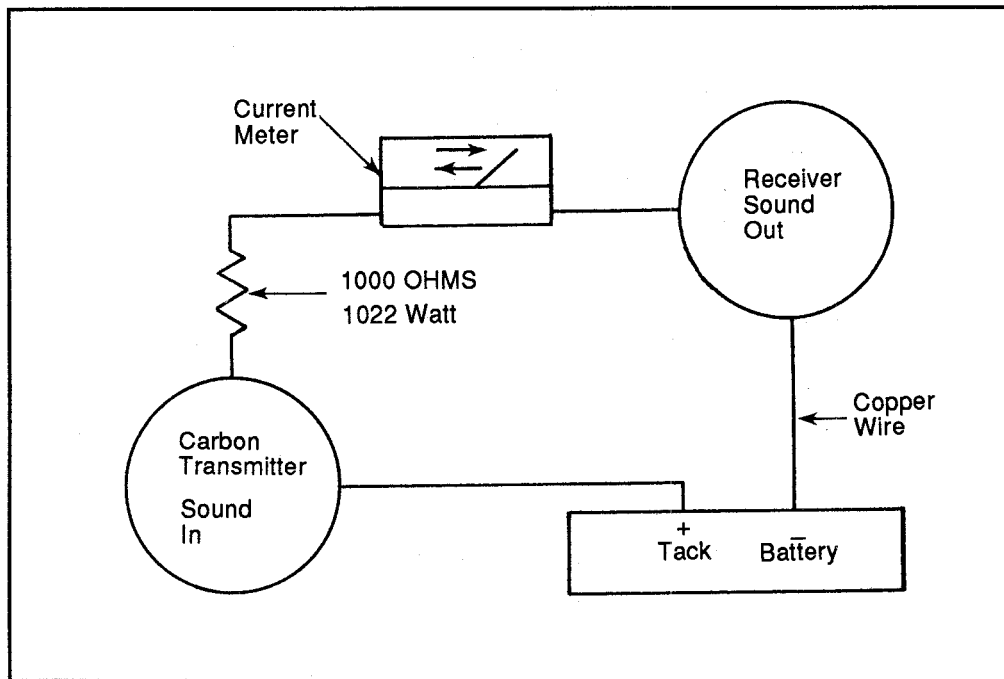
The vibrating action produces different variations in air pressure which are translated by the ear into useful sound.

Figure 6 shows an overly simplified telephone. This would be the minimum required to make a working telephone. It consists of a transmitter (carbon microphone), receiver (earphone), resistor (1000 Ohms, 1 or 2 Watt), and a battery (at around 6 volts).

### Telephone Network

Older telephones use an electronic box for the needed electronics in a telephone whereas newer phones use a PC board. These devices are known as the telephone network.

Both types of network use RF filters, side-tone balancing circuits and impedance-matching components. These networks are the most reliable (especially the older electronic box) components in a telephone.



**Figure 6:** Simple, but operational telephone

### Telephone Ringer

The telephone ringer circuit is typically activated by a 30 Hz signal. In those areas in which more than one home share the same line, each phone on the party line is tuned to activate at a different frequency. Any other telephones will experience a high impedance at the tuned location and not cause a ringing.

When the correct frequency (30 Hz) is received, the circuit causes the hammer to strike the bells and indicate an incoming call. It should be noted that the electronic “buzzer/bell” functions in the same way except that there is no mechanical bell.

The ring duration in the U.S. is set for 2 seconds on and 4 seconds off. In England, the ring is set for two short bursts followed by 2 seconds off.

### Wiring Specifications

Wire for telephone service (by ANSI standards) must be solid copper wire and should have at least eight conductors, or four pairs of wires. Approved wiring will be classified as Communication Wire (CM). Older wire is 4-wire (two pair) and is still acceptable in household wiring.

These wires must be individually paired and twisted together. Flat wire is not acceptable. Wire smaller than 26 gauge should not be used at any time. Typically, wire run distances are limited to no more than 250 feet for 22 gauge wire, 200

feet for 24 gauge, and 100 feet for 26 gauge. Distances greater than these can result in an overloading of the wiring system and cause telephone sets or systems to malfunction. The universal standard color code is:

**Two-Pair Wiring**

	Tip/Voltage	Ring/Ground
Pair 1	Green	Red
Pair 2	Black	Yellow

**Four-Pair Wiring**

	Tip/Voltage	Ring/Ground
Pair 1	White	Blue
Pair 2	White	Orange
Pair 3	White	Green
Pair 4	White	Brown

Two-pair wiring allows for two phone lines to be connected in one home, although typically only 1 line is hooked up. Four-pair wiring allows up to four lines to be connected within a home. Standard telecommunications wiring can carry from 48 to 240 volts DC. To avoid any accidental shock, disconnect wires from the customer service box before attempting any wire repairs.

**Customer  
 Telephone Access  
 Box**

Since the breakup of A.T. & T., phone maintenance by customers became optional. Telephone maintenance and service by the telephone company ends at the point where the outside telephone wire meets the customer telephone access box. Internal maintenance and servicing is provided for a fee by the telephone company.

A typical modern access box is shown in Figure 7. The incoming telephone cable is located in the center housing and is not accessible to the average person. Only certified telephone repair-persons are allowed access to this section. Within a typical box will be the provisions for two phone lines (four are possible with the eight wires provided).

On one side is the wire pair for line one and the other side is for line two. The wiring color scheme depends on the company that installed the telephone drop cable to your home. Either there will be two sets of two-pair wiring or one set of four-pair wiring.

The only maintenance you can do is to inspect the wires leading into the house and test the incoming signals. These boxes will have the provision for plugging a phone into the modular connections for line one and line two (if used) to decide if the problem is within the home wiring or is a fault needing correction by the phone company.

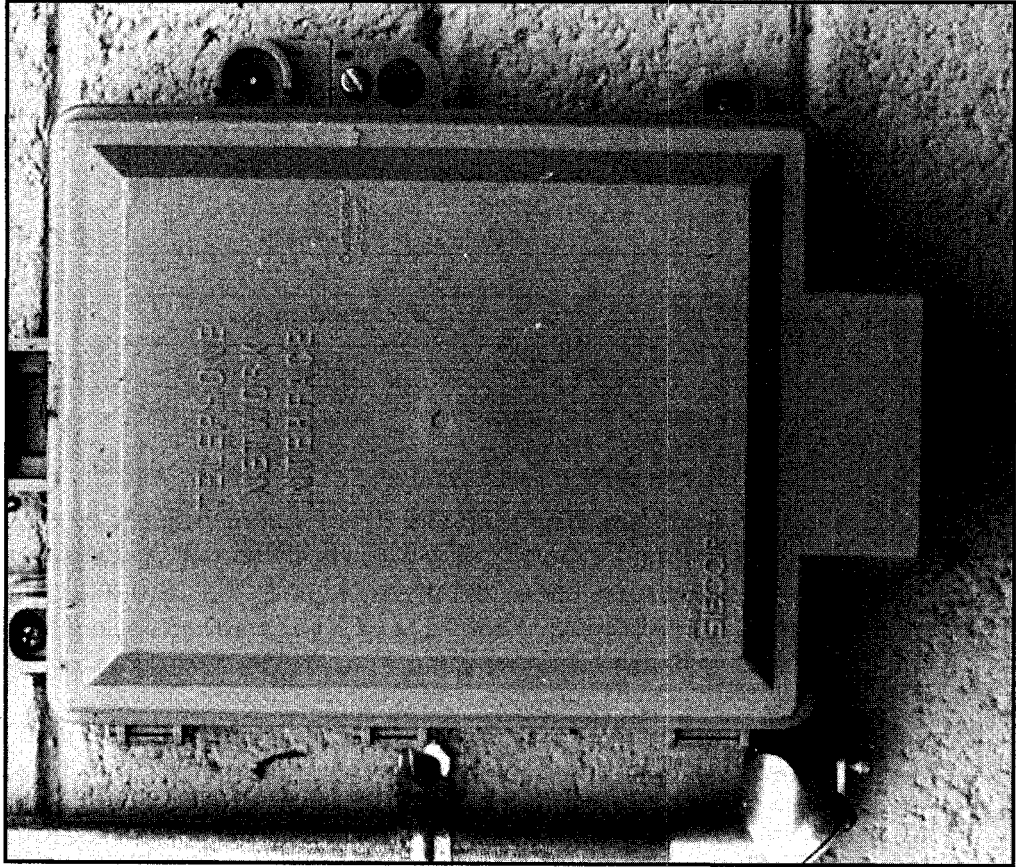


Figure 7: Customer access box

# 11/Tel

## Telephone

11/Tel - TE

Test Equipment

## 11/Tel

### Telephone

### 11/Tel - TE

#### Test Equipment

Besides the normal bench test equipment used for troubleshooting, a tone generator and a test phone are invaluable for checking telephone systems. All should be available from various electronic test equipment suppliers. Access to this equipment is fairly simple, especially since consumers and companies other than the phone company are allowed to work on home wiring and phones.

#### Tone Generator

A tone generator is hooked to a phone line to trace a signal. When the signal cannot be found, you know your problem lies between the signal and the test point. Tone generators are ideal for locating breaks in phone lines. Tone generators will perform such functions as pair identification, line continuity checks, and on and off hook/line activity indications.

The tone generator can be used with either the line probe or the test phone (handset) below. If you don't care to spend the money on an actual tone generator, you can often get by using almost anything that emits a low-power signal. For example, a transistor radio that has an earphone jack is sending a low-voltage signal through that jack. By adapting an earphone plug and wire with alligator clips (instead of an earphone), the radio becomes a small tone generator of sorts. The signal will be weak but in many cases can still be detected on the other end of the wire pair with a probe, test phone or even with a DMM.

#### Line Probe

A line probe will be needed to find the tone being generated. A simple line probe has a sensing probe and a test light or a speaker that provides an audible sound when the signal is found. This probe is also good for finding a signal in one wire from a group of wires. For example, if a signal is fed into a cable of wires at one end, it's a simple matter to probe the other end to find which wire is carrying the signal (and which wires are not). This not only helps you to identify the wires being used, but also the condition of those wires (i.e., is there continuity?).

#### Test Phone

A test phone is another good piece of test equipment. A test phone is simply a portable phone with the ability to be clamped (with alligator clips) to wire pairs

**11/Tel**  
Telephone

---

11/Tel - TE

---

Test Equipment

---

---

for checking a phone line. You can make your own by taking an existing inexpensive handset and fitting the cable from it with alligator clip leads. If the handset has a modular plug, you can easily make a separate wire with the clips, thus making the handset useful as a test set while still being able to use it as a regular phone. (If you make this, keep in mind that the jack for the handset is smaller than the jack for the wall outlet. You must have the proper sized wire and jack.)

11/Tel - TR	Troubleshooting and Repair
11/Tel - TR - CP	Cordless Phones
11/Tel - TR - CP - D	Design

## 11/Tel - TR - CP

### Cordless Phones

## 11/Tel - TR - CP - D

### Design

#### Introduction

The invention of the telephone revolutionized our world. The first telephones were crude, required an operator to make calls, and tended to have short cords. Longer cords soon became available. This gave the user some room to move, but a wire still had to be dragged along.

Advances have made telephone service extremely reliable. The first steps have been taken to make this mode of communication virtually wireless. Geosynchronous communications satellites can be used to send signals across country (or around the world) without the need for wires or cables between the cities. It is predicted that before much longer cellular phones will pass signals through satellites, giving them coast-to-coast capability.

The cordless phone was first introduced in the early eighties. Suddenly people were no longer tied to wires or outlets. The base unit could be located at almost any convenient phone outlet. The handset could be taken anywhere in the home, without any connecting wires.

When cordless phones first became available, stores had a hard time keeping up with the demand. Especially during the holidays, the stock was often depleted. As with everything else, the cordless phone of today is different from those first models. The earliest models could only receive calls and the signals tended to be somewhat noisy. Today, even the least expensive models have remarkably quiet signals. You can even find models that have two lines, built-in intercom features and much more. Today's units are much smaller and lighter.

A few years ago, Uniden produced one model with two very interesting features. One was that the phone folded. Even unfolded the handset was small. Folded, it fit very easily into a shirt pocket. Even more interesting and useful was a headphone jack on the top of the handset. This made it possible to insert a headphone/microphone, tuck the phone in your pocket, and be mobile while having both hands free.

# 11/Tel Telephone

11/Tel - TR	Troubleshooting and Repair
11/Tel - TR - CP	Cordless Phones
11/Tel - TR - CP - D	Design

**Simplex vs. Duplex** Originally, except for the larger and more expensive commercial equipment, phone/radio patching could only work in one direction (called simplex). Each person would have to wait for the other to finish talking because the signals could only flow in one direction at a time.

Regular telephone service is duplex. Signals can go in both directions, meaning that both users can talk simultaneously. Cordless phones also use this method. Two frequencies are needed — one for transmission from the base unit to the handset, and one for the signals from the handset to the base.

## Frequency Allocations

The most important changes in cordless phones have been the frequency allocations for duplex operation. Originally, 1.7 MHz (base transmitter) and 49 MHz (handset transmitter) bands were used. These are now called low band units. The main reason for using the 1.7 MHz band for the base units was to couple the base transmitter to the AC power lines of the home. This allowed the wires of the home to become the base transmitting antenna. The idea was to increase the range. The problem was that electrical interference was increased. Worse, in some cases the wiring was inside metal conduit. This effectively blocked the signals. It was particularly common in commercial buildings.

Another problem with the 1.7 MHz band was that only 9 frequencies were available. The more popular cordless phones became, the more of a problem this caused. It wasn't uncommon for neighbors to find themselves on each other's phone lines. Making matters more frustrating, most of the earlier cordless phones came with a preset frequency and no switch to change it.

By changing the base transmitter to the 46 MHz range, more frequencies were available. Interference dropped and now is generally a problem only in high density apartment complexes. In such buildings it's not unusual to hear one side of a conversation — or to find yourself charged for someone else's phone call.

## Security

This brought out models with built-in security systems. These may be as simple as dialing lock-outs. In this case, as long as the handset is in the cradle of the base, the dial-out function of the base is shut off. You can still use the other telephones in your home as normal, but the base will reject any radio signals.

As with any telephone, the cordless phone must be able to handle several conditions that occur on a typical telephone line. Usually it does this in much the same way as any telephone. Other times, the base must interpret the condition, send this to the handset and be able to receive the handset's response.



# 11/Tel Telephone

11/Tel - TR	Troubleshooting and Repair
11/Tel - TR - CP	Cordless Phones
11/Tel - TR - CP - D	Design

## Open Circuit Voltage

The standard telephone line has 48 V across it with the telephone disconnected (“on-hook”).

## Line Current

When the telephone is taken “off-hook,” it is connected to the telephone line, allowing current to flow from the main telephone lines and through the telephone. The current is produced by the telephone company’s central office. It flows through their switching equipment, through the lines, through the telephone, back through the lines and again through the switching equipment. When the phone is taken “off-hook” and is dialed, the central office routes the call. When the phone is put back “on-hook,” the central switching equipment automatically brings everything back to normal.

## Dial Tone

Once the central office equipment recognizes the “off hook” condition, it sends a dial tone signal, indicating that the switching equipment is ready.

## DTMF Tones

Dual-tone multi-frequency (DTMF) signals are sent by the telephone to the central office using the keypad of the handset. This combination of blended frequencies tells the switching company which number is being dialed. As shown in Table 1, when a key is pressed two tones are sent at the same time. One is related to the row in which the key is located; the other is related to the column. For example, the numbers 1, 2 and 3 are all in the same row but in different columns. The numbers 2, 5, 8 and 0 are all in the same column but in different rows. It’s the combination of row and column that generates the specific DTMF for that key.

Row 1,2,3	697 Hz	Column 1,4,7,*	1209 Hz
Row 4,5,6	770 Hz	Column 2,5,8,0	1336 Hz
Row 7,8,9	852 Hz	Column 3,6,9,#	1477 Hz
Row *,0,#	941 Hz		

## Call Flash

If the line you are using has special features such as call waiting, the telephone must momentarily be disconnected by “flashing” the hookswitch. The central office recognizes this “flash” as a request to transfer the line to the waiting call and to put the original call “on hold.” Some older cordless phones are unable to provide a call flash from the handset.

## Ring Signal

When an incoming call occurs, 90 V at 20 Hz is sent to the telephone. In a conventional phone this operates the bell, buzzer or other signaling device. In a cordless phone the ring signal is interpreted by the base unit and sent by radio to the handset.

## Power Circuits

The base unit provides two important functions. One, of course, is to provide the link between the handset and the telephone lines. The other is to recharge the nicad batteries of the handset.

### Base Unit Power Supply

Figure 1 shows a typical base unit power supply. It takes power from the nominal 120 VAC and converts it to the needed value of DC for the handset. There are two general ways to do this. One is to plug the base directly into the wall outlet, with an internal power transformer handling the job. The other, more common way, is to use a wall transformer. This kind of transformer plugs into the wall outlet and converts the power to the needed value before it ever enters the base unit.

### Wall Transformer

There are advantages to using a wall transformer. It reduces the weight of the base unit. More important, it keeps 120 VAC out of the base, making the unit much safer. Because the wall transformer essentially isolates the base, you will probably not find a fuse in the base unit. Typically, the wall transformer is a high impedance device that is fairly immune to most short circuits in the transformer secondary winding. It is usually the only part of the phone that is UL listed.

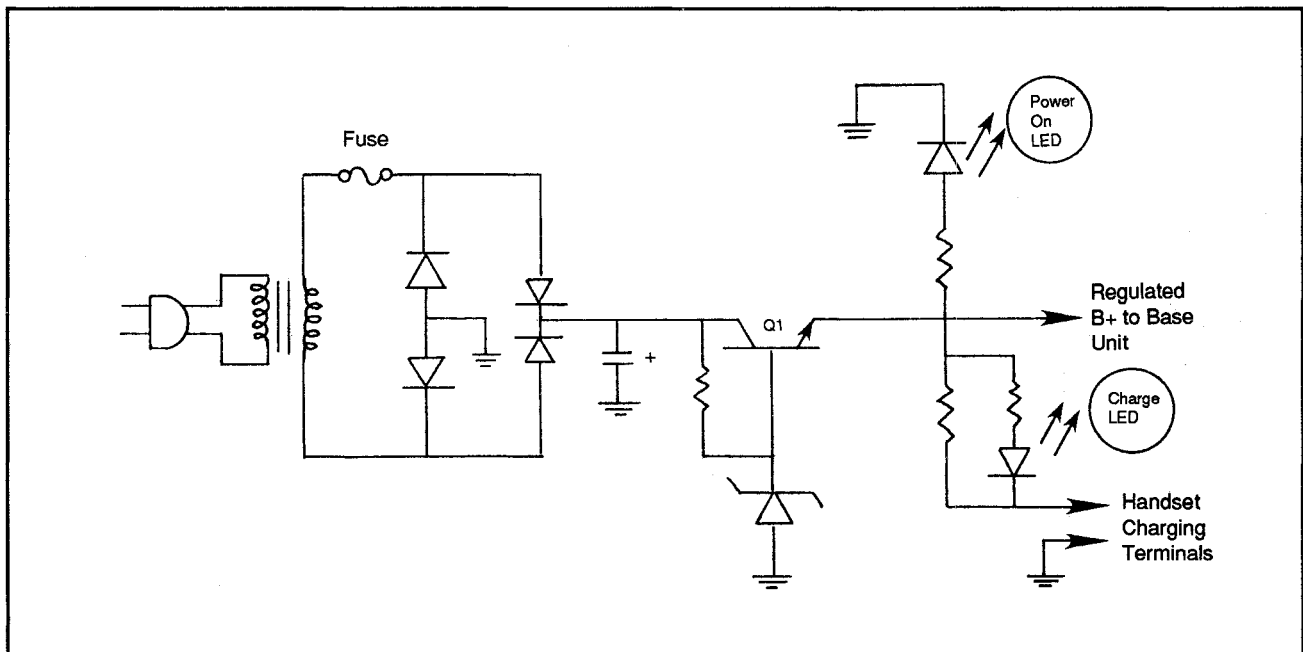


Figure 1: Base unit power supply

### Rectifier Filter

The rectifier filter is a standard bridge configuration. A series-pass transistor with the base regulated by a zener diode provides the regulated DC voltage to operate the electronics of the base unit. It also supplies the low level DC voltage to the contacts of the charger. Note that when the handset is placed in the base cradle, the contacts complete the circuit and the LED indicator lights.

The nicad batteries in most handsets are 3.6 VDC. As is often the case in battery-powered devices, particularly those that use nicads, most problems can be traced to the battery pack rather than to the phone itself.

### Battery Pack

The typical battery pack consists of three prewired cells connected in series. The individual cells may be wrapped in plastic, or could be inside a case. Although it is preferable to get an exact replacement pack, sometimes the only choice is to purchase individual cells of the appropriate size, and then output and wire them yourself.

### Nicads

Nicads hold voltage well and give a consistent supply. Once they approach the discharged state, they tend to drop power rather suddenly. Worse is that some can develop a memory. The usual cure is to let the batteries discharge completely.

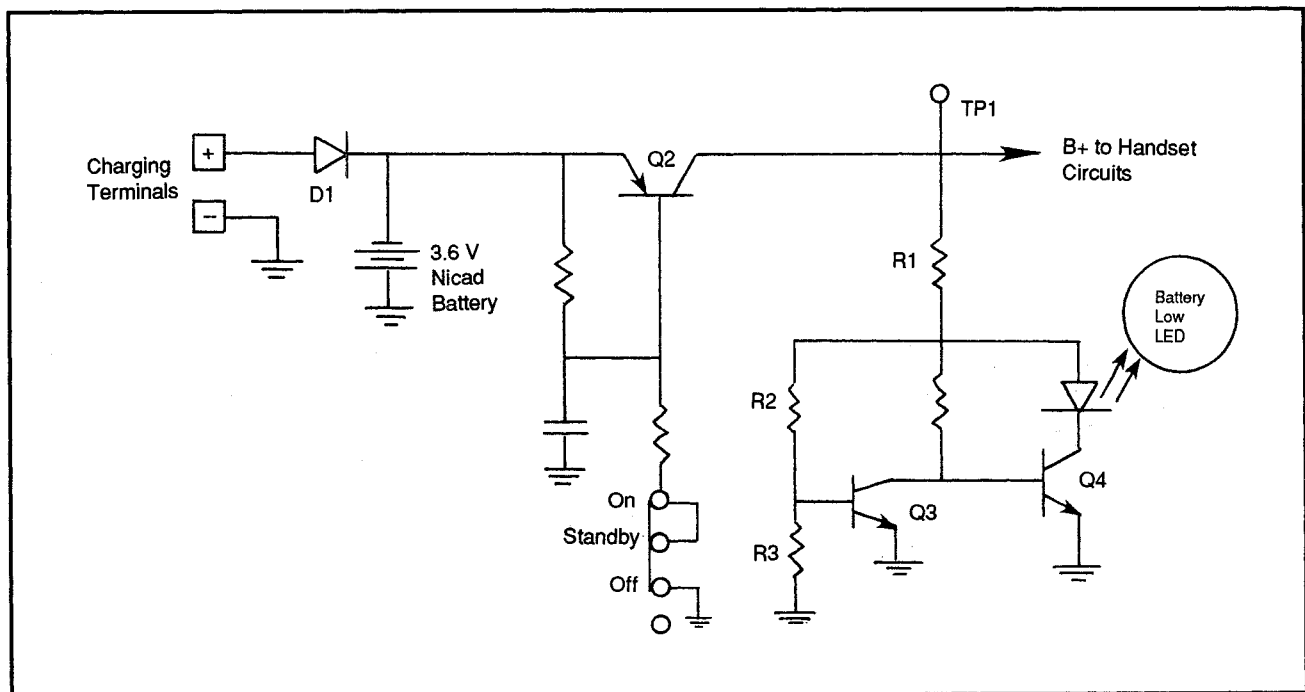


Figure 2: Typical handset power circuit

11/Tel - TR	Troubleshooting and Repair
11/Tel - TR - CP	Cordless Phones
11/Tel - TR - CP - D	Design

Some suggest the risky procedure of “kicking” the batteries with forced high current.

Measuring the voltage of the battery pack usually requires removing the handset case (or battery door) and measuring directly across the battery terminals. This is because a diode (D1 in the schematic) is used to prevent reversed voltage from being applied to the handset circuits. Testing for battery level by probing at the charging contacts on the outside of the case is likely to give a false reading. Don't be misled into thinking that the battery pack is dead when in fact the protective diode is simply blocking the meter's current.

If the handset doesn't have an access door for the battery pack, carefully inspect the case. If entry isn't clear, look for plastic covers. In many cases a screw is hidden beneath the phone number cover. This screw is almost always a phillipshead. With this screw removed, carefully unsnap the two halves of the case. Work around the crack between the two parts with a small flat-bladed screwdriver. Pushing in on the sides may also help.

In some models, power to the handset circuits is controlled by a simple switch. In our example (see Figure 2), a PNP transistor is used between the battery pack and the circuitry. The base of this transistor is biased to the emitter while the power switch is off. This makes the transistor “Off” and no current flows. When the power switch is set to either standby or on, the biasing is changed to bring the base of the transistor toward ground, which turns the transistor “On.” Whichever way power switching is handled, the point marked TP1 is a good spot to measure the voltage being made available to the set.

## LED

Many sets have an LED showing a low battery condition. Obviously, if the battery is completely dead the LED will not light at all. It also won't light if the battery is providing sufficient voltage.

The LED is controlled by transistors Q3 and Q4. Q3 is forward biased by the series resistor network of R1, R2 and R3. Being forward biased, the collector of Q3 is near ground, causing Q4 to be open. This turns off the LED. As the battery drops below 3.6 VDC, bias on Q3 shifts, raising the collector voltage on Q3. This turns on Q4 and the LED lights.

## The Base Unit

The interconnection between the base and the outside phone lines is made through a standard modular jack and connector. The connection is made directly

**11/Tel**  
Telephone

11/Tel - TR  
11/Tel - TR - CP  
11/Tel - TR - CP - D

Troubleshooting and Repair  
Cordless Phones  
Design

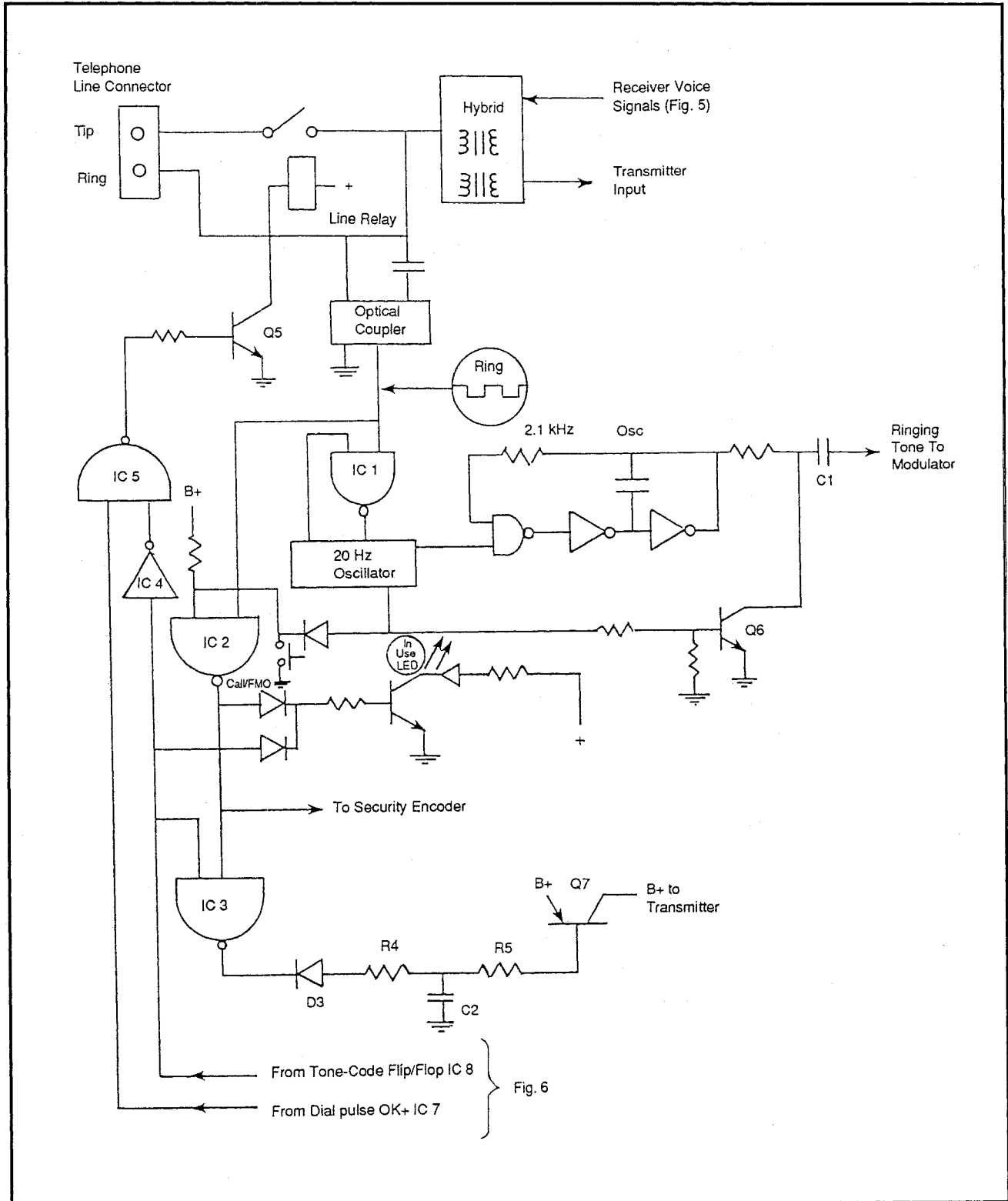


Figure 3: Incoming ring detector and DC control

# 11/Tel Telephone

11/Tel - TR	Troubleshooting and Repair
11/Tel - TR - CP	Cordless Phones
11/Tel - TR - CP - D	Design

to the tip (T) and ring (R) of the telephone lines. Some of the newer models offer two-line service. In such cases the base usually has two modular cords — one for each line. It may also use a single four-wire cord. Troubleshooting two-line phones is the same as single-line phones. The only real difference is that the connection side is much like having two separate phones.

**Hybrid Transformer** Interface to the telephone line is accomplished by using a hybrid, as shown in Figure 3. This hybrid consists of a specially wound transformer that can handle the line current without saturating the core, and still provide isolation between the talk and receive paths. The transformer must be able to pass frequencies from between 300 and 3500 Hz. The normal impedance of the hybrid transformer is 600  $\Omega$ .

As stated earlier, the function of the hybrid transformer is to isolate, transmit and receive. This separates the signals coming from the telephone line so that the incoming voice signals are sent only to the transmitter. Similarly, the signals from the receiver of the base must be separated from the transmit signals and applied to the telephone line. (If the transmitter and receiver were tied rather than separated, excessive signals from the receiver would be retransmitted in a sort of feedback.)

It's important to note, however, that a small amount of the signal going out to the telephone line from the handset transmitter is purposely fed back to the handset receiver. This produces a low level sidetone. The purpose is to allow the user to hear himself or herself talking. This is important. Without the sidetone, speaking is more difficult. The user also has a tendency to speak louder if he can't hear himself in the receiver.

Note in Figure 3 the relay contacts between the hybrid and the telephone line. This is the "hookswitch." When the handset is turned off, placed in the base unit for charging, or when the base unit is disconnected from the incoming 120 VAC supply, power to the relay is removed. The relay contacts open and the telephone line is disconnected.

This same relay handles other important operations. When the "flash" is sent (such as to switch lines during call waiting), this relay is momentarily opened. If the handset is switched to send pulse signals for dialing instead of tone, the relay pulses. (This is done by the base detecting a pilot tone sent from the handset. If this pilot tone is absent, the tone/pulse flip-flop shown in Figure 6 is reset.) The relay driver is transistor Q5. When in the off state, it releases the line relay. Incoming calls bring the 90 V 20 Hz ring signal. Figure 3 shows the circuitry used to detect this, and to send the ring to the handset.

11/Tel - TR	Troubleshooting and Repair
11/Tel - TR - CP	Cordless Phones
11/Tel - TR - CP - D	Design

Typically, an optical coupler is connected across the telephone line and in series with a DC blocking capacitor. As soon as ringing starts, the optical coupler output goes low, enabling the OR gate (IC-1) that is connected to the 20 Hz oscillator. With the OR gate enabled, the 20 Hz oscillator is released and begins to turn the free-running 2.1 kHz signal on and off at a rate of 20 Hz. The 2.1 kHz signal is fed to the transmitter modulator through capacitor C1.

Just ahead of this capacitor is the tie to the collector of transistor Q6. If the base of Q6 is biased high, it clamps the 2.1 kHz signal to ground, blocking the tone from transmit. With the input to Q6 low, the tone is released. This high/low condition is provided by either the 20 Hz oscillator or by the “page” button on the base unit. (This feature is meant to signal a person carrying the handset from the base unit, but in reality is more often used to locate a misplaced handset.)

Diode D2 provides isolation between the 20 Hz oscillator and the “page” button. The output of a NAND gate (IC-2) goes high when there is an incoming ring signal, or when the “page” button is pressed. This high from the NAND gate turns on the “in use” LED and activates the security encoder to send the signal to the handset.

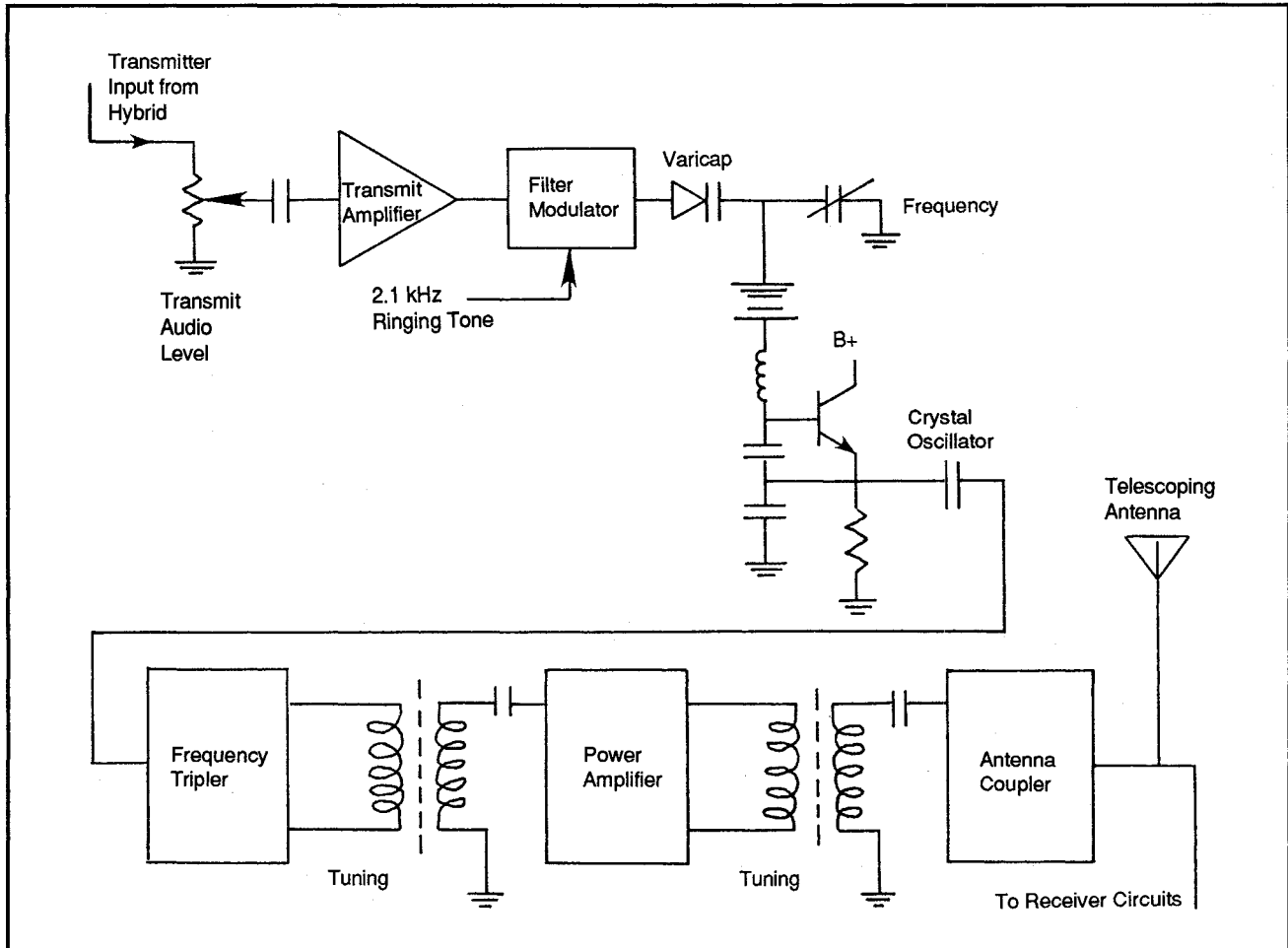
As all this happens, IC-3 turns on the series-passing transistor Q7 to provide power to the transmitter. When the output of IC-3 goes low, the base of Q7 is biased low through the network of D3, R4, R5 and C2. (The capacitor C2 is discharged through R4 and D3.)

Between the incoming ring signals, IC-2 output goes low which in turn causes the output of IC-3 to go high. Because of diode D3, the capacitor C2 is discharged, then slowly raises its voltage charge. As a result, Q7 stays turned on and power is continued to the transmitter.

When the handset answers the call, the input from the tone/code flip-flop goes high, dropping the output of IC-3 low, keeping the transmitter powered and turning on the “in use” LED.

This high is inverted in IC-4 and is fed through the NOR gate, IC-5, to Q5. Q5 is turned on which closes the line relay, thus seizing the telephone line. (IC-5 turns on Q5 if there is a high on the flip-flop and a low on the dial pulse circuit. See Figure 6 for more details on this part of the circuitry.)

Once the call has been established, incoming voice signals form the telephone line and are separated from the outgoing voice signals by the hybrid transformer. Figure 4 shows the base unit transmitter section. The input from the hybrid



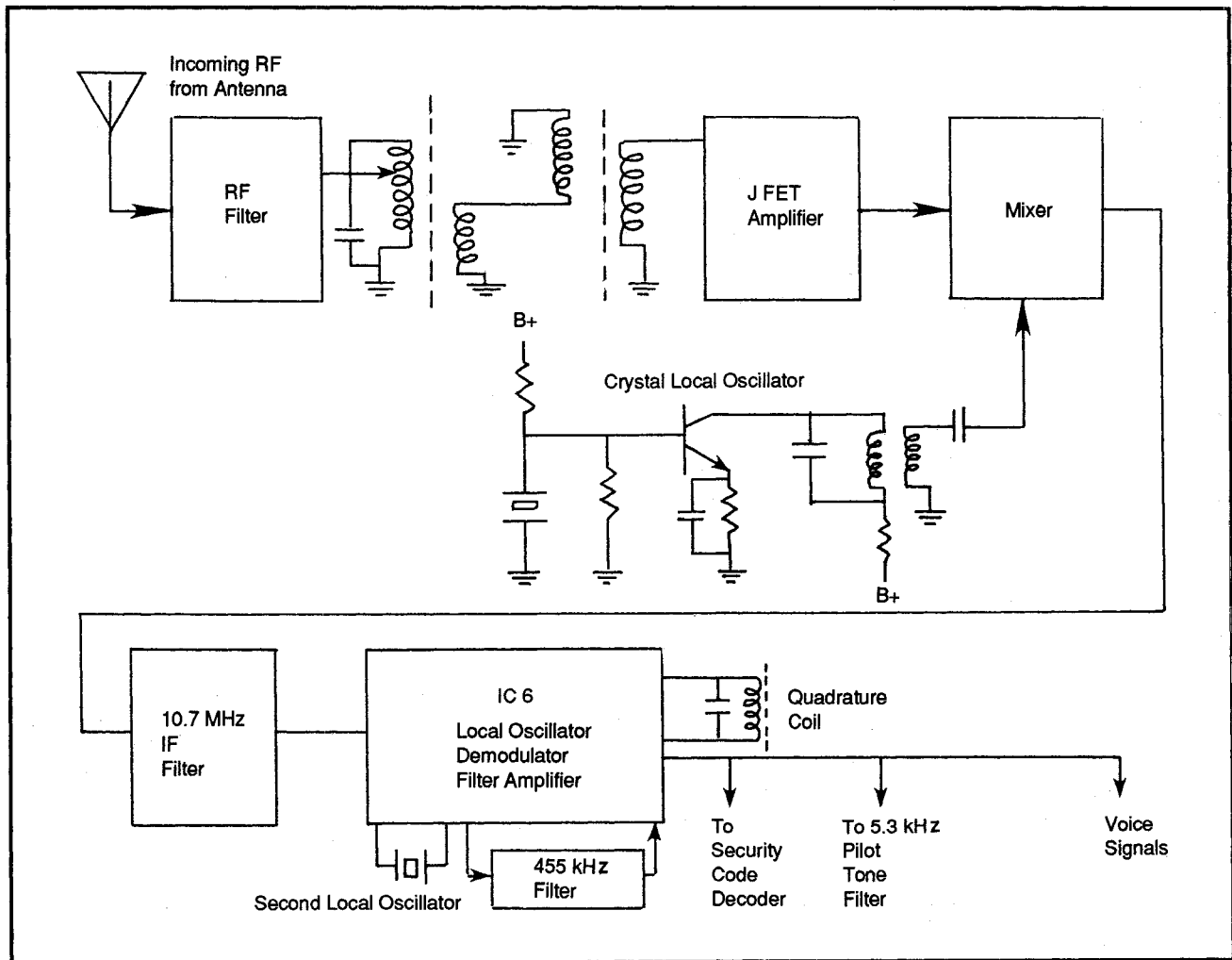
**Figure 4:** Base unit transmitter

transformer is fed through an amplifier into the transmitter modulator circuit. The modulator is a varicap diode across the crystal trimming capacitor.

Varicap diodes have the characteristic of changing in capacitance as the voltage across them changes. In this case the varying voltage is either the audio voice signal or the 2.1 kHz ring/page signal. The varying capacitance pulls the crystal frequency slightly to follow the audio voltage. This results in a frequency modulated (FM) carrier signal, with the carrier using a crystal in the 16 MHz range. This is tripled in frequency, then amplified and fed into an antenna matching network, and finally to the telescoping antenna that is shared by the transmitter and the receiver.

Figure 5 shows the block diagram of the base unit receiver. RF signals from the

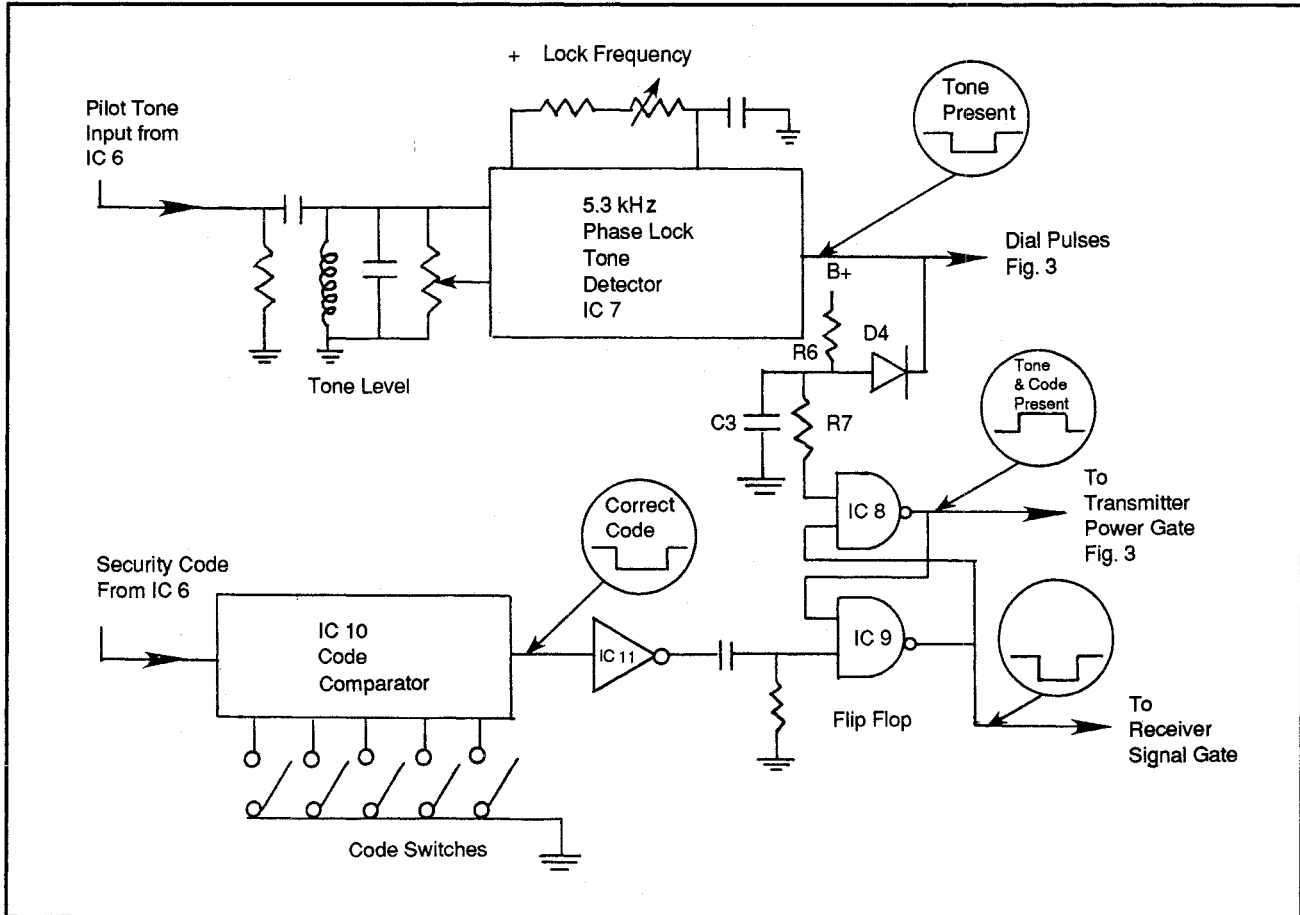




**Figure 5:** Block diagram of base unit receiver

telescoping antenna are fed through the RF filter. (This filter keeps the transmitter RF out of the receiver.) The incoming signals go to the JFET driven RF amplifier and then to the first mixer. The first local oscillator, attached to the mixer, is crystal controlled.

The first IF (intermediate frequency) is in the 10.7 MHz range. From here the signal passes into IC-6, which is a MSSP-type (medium scale special purpose), and the heart of the receiver. It contains the second local oscillator and a filter for the second IF frequency of 455 kHz. There is also a limiter to reduce noise spikes and a quadrature coil FM demodulator. The demodulated signals consist of the voice signals, a 5.3 kHz pilot tone and the security code from the handset.



**Figure 6:** Tone/code detectors and transmission flip-flop

### Pilot Tone

Figure 6 shows the pilot tone coming from IC-6 (the demodulator). It is filtered, then adjusted in level and fed to IC-7. IC-7 is a 5.4 kHz phase-lock loop tone detector. Note that the locking frequency is adjustable. The operating bandwidth is preset. Adjustments aren't critical and only rarely need resetting.

With no tone present, the high from IC-7 to the flip-flop (IC-8 and IC-9) forces the output of NOR gate IC-8 to be low. This low output enables NOR gate IC-9. Since the other gate input to IC-9 is held low with a resistor, its output is high. This ensures that the IC-8 output is kept low. The transmitter is then turned off and kept off.

With a pilot tone present, the low from IC-7 enables NOR gate IC-8. Its output becomes high when the output from IC-9 is low. This happens when the security code is received from the handset transmitter. If the code matches the preset code,

a “correct code” signal is sent by the code comparator (IC-10) in the form of a low output. This is inverted in IC-11 and is sent to IC-9 in the form of a short positive pulse. The pulse drives the output of IC-9 to go low, which forces the IC-8 output to go high. The interconnection between IC-8 and IC-9 causes this condition to keep the IC-8 output low.

The flip-flop is set and a signal is sent to the circuitry (see Figure 3) to turn on the “in use” LED indicator. The transmitter is powered and the line relay is closed due to being pulled by Q5. (Q5 is turned on when both inputs to IC-5 are low.) The setting of the flip-flop results in a high level into the inverter IC-4. This in turn provides one of the lows being fed into IC-5. (The other low input is provided directly from the tone detector, IC-7, when the tone is present.)

If the tone/pulse switch on the handset is in the pulse position, pushing a key generates a string of pulses which interprets the 5.3 kHz pilot tone. IC-7, the tone detector, outputs a string of pulses which matches the number pressed on the keypad. This string of pulses, and a second input with IC-5, drives the line relay Q5 on and off.

## Relay

The relay triggers pulses in the telephone lines. The central switching office reads these as coming from a dial-type telephone. If the # key is depressed on the keypad, there is a 500 ms interruption of the pilot tone. This short pulse is sent

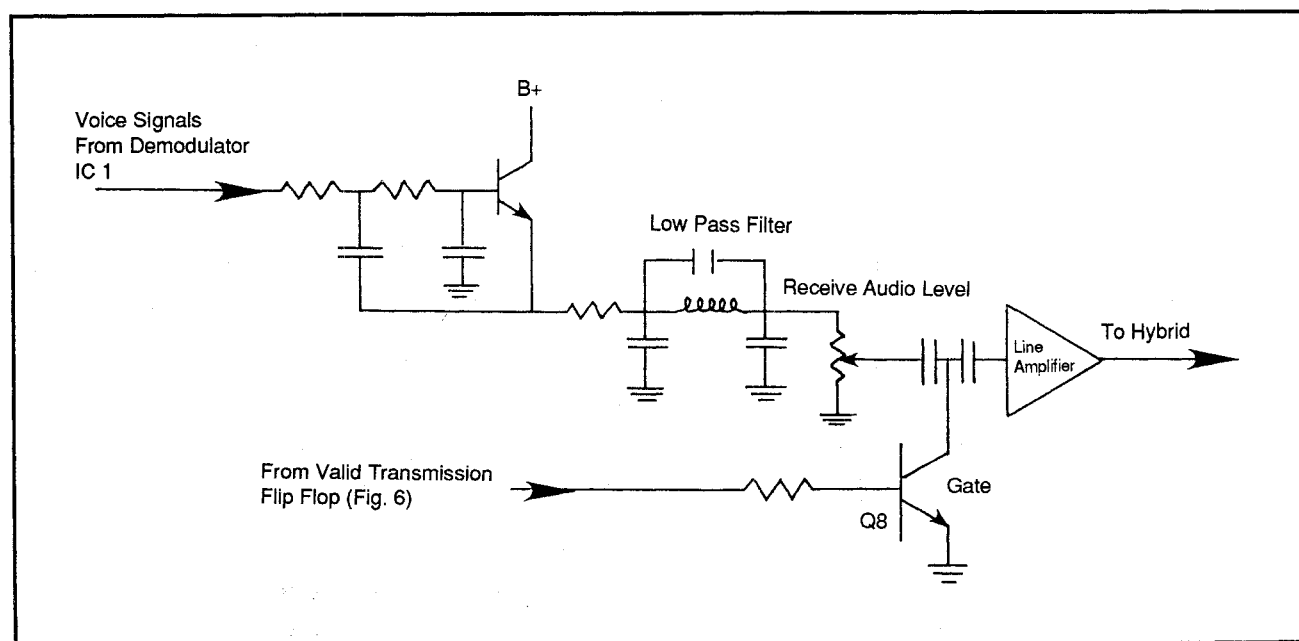


Figure 7: Receiver filter-amplifier-gate

# 11/Tel

## Telephone

11/Tel - TR	Troubleshooting and Repair
11/Tel - TR - CP	Cordless Phones
11/Tel - TR - CP - D	Design

to the line relay and is interpreted by the central office as a hookswitch flash. (This activates features such as “call waiting.”)

The network of R6, R7, C3 and D4 between the output of IC-7 and the input of IC-8 keeps the flip-flop set during the interruptions caused by using dial pulses or by using the # key. When the output of IC-7 goes high momentarily, the diode is back-biased and the capacitor begins to charge slowly. IC-8 remains on. When the output of IC-7 returns to low, the capacitor is discharged through the diode. This action causes a time delay so that the flip-flop ignores the pulses.

Thus far we have two time delay circuits. The one just discussed keeps the transmitter powered between dial pulses. The other, shown in Figure 3, keeps the transmitter powered between incoming ring signals.

**Audio Voice Signal** The third incoming signal from the demodulator (Figure 5) is the audio voice signal. Figure 7 shows how the signal is fed through a low-pass filter. This removes the 5.3 kHz pilot tone and any other frequencies above the filter cutoff (usually in the 3.5 kHz range).

The received signal is gated off by shunting the signal to ground via transistor Q8 when a high level signal is given to the base of this transistor. This occurs when the pilot tone and security code have not been received, and the flip-flop has not been set. Once both signals are received, the gate is opened and received signals are fed through the line amplifier to the hybrid and on to the telephone line.

**Handset Circuits** Figure 8 shows the handset receiver circuitry. As with the base unit, the handset uses a telescopic antenna. Normally, the receive sensitivity is good enough to pick up the ringing and “page” tones even if the antenna is collapsed all the way. The voice receive and transmit capabilities are significantly improved with the antenna extended.

From the antenna, the received signals go through a 46 MHz filter to remove any of the transmitted frequencies. (The transmitter uses the same antenna through its own 49 MHz filter.) From the filter, the receive signal is amplified and mixed with a crystal controlled local oscillator to get the first IF frequency of 10.7 MHz. This is filtered and sent to IC-11, which is similar in function to IC-6 in the base unit. It provides a second local oscillator and a second IF filter at 455 kHz. It also has a quadrature coil for detecting the FM signal. Outputs consist of the digital security code and the 2.1 MHz ringing tone from the base unit, and the audio signals from the telephone line as processed through the base unit.

**11/Tel**  
Telephone

11/Tel - TR

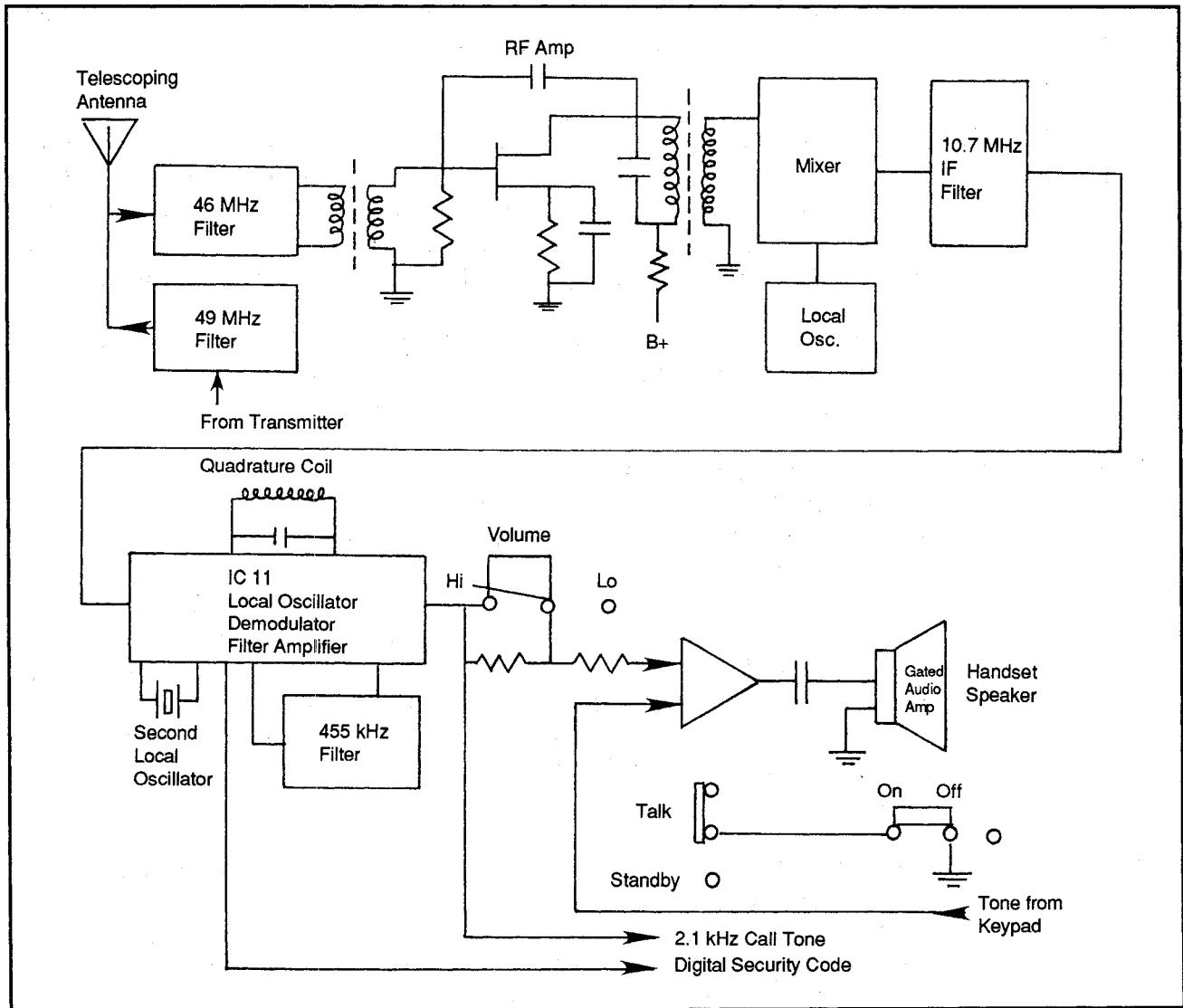
Troubleshooting and Repair

11/Tel - TR - CP

Cordless Phones

11/Tel - TR - CP - D

Design



**Figure 8:** Handset receiver circuitry

The audio is sent through a simple low/high volume switch into an audio amplifier to the handset speaker (earphone). The amplifier is turned off when not in use by the on/off and talk/standby switches. Tones are sent from the keypad circuit to the amplifier so the tones may be audibly heard during dialing.

**Transmit Circuitry**

The transmit circuitry is similar to the base unit transmitter circuitry. This is shown in Figure 9. A microphone in the handset provides the audio signal source. This signal is amplified and fed to the varicap FM modulator along with the

# 11/Tel Telephone

11/Tel - TR

Troubleshooting and Repair

11/Tel - TR - CP

Cordless Phones

11/Tel - TR - CP - D

Design

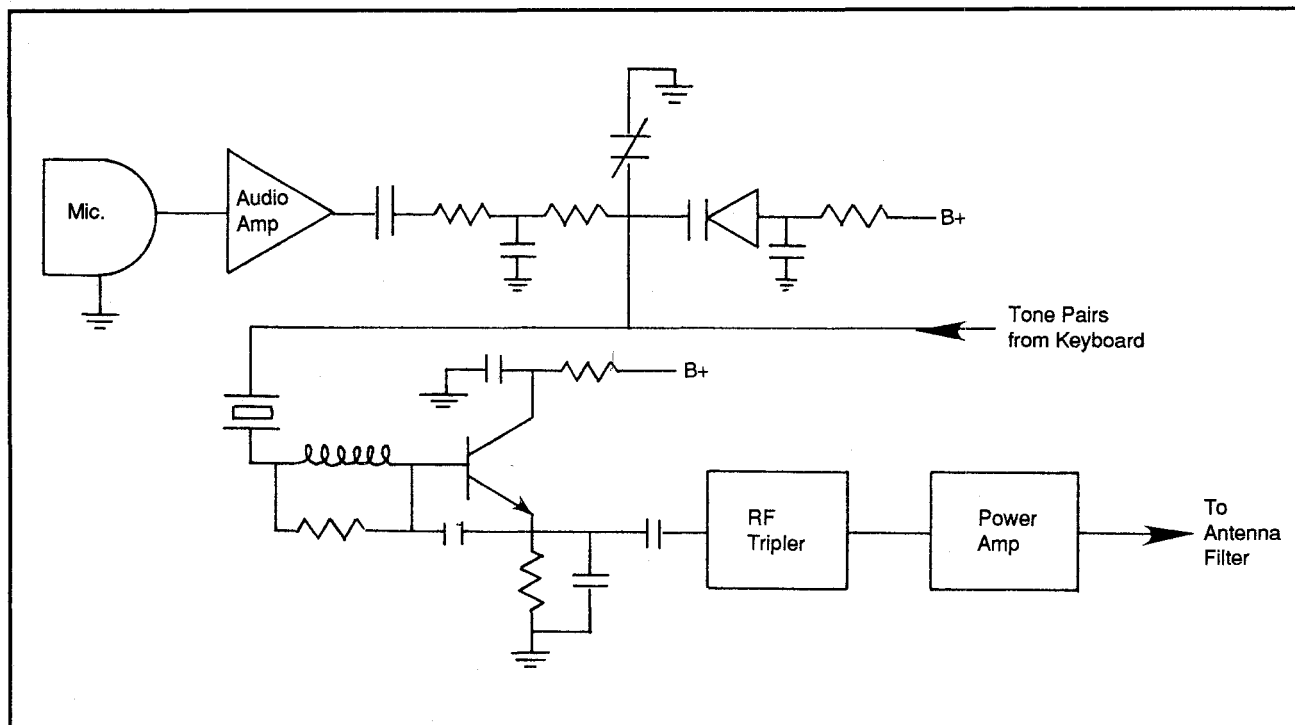


Figure 9: Block diagram of handset transmitter

dialing tone pairs (DTMF), the 5.3 kHz pilot tone and any security codes in use. As with the base unit, the FM signal generated by the crystal oscillator is tripled, amplified and sent to the transmit antenna through the 49 MHz filter.

Figure 10 shows the dual tone, pilot tone and code generator. This is the heart of the cordless handset. The keypad has 7 basic connections plus a special line for the # key. The # connection turns off the 5.3 kHz gate, stopping the signal from the free-running 5.3 kHz pilot tone generator. This gate has a 500 ms delay time so that no matter how long the # key is depressed and held, the pilot tone is only removed for 500 ms at any time. The hookswitch flash needed to activate call waiting is thus available without the chance of total disconnection.

The 7 basic connections from the keypad represent the 4 rows and 3 columns on the keypad that are responsible for the dual tones generated by the oscillator.

## Keypad/Oscillator Circuitry

The keypad and oscillator circuits are typical of every conventional touch-tone telephone. They are fed into a gated amplifier in addition to the gated pilot tones. These are sent to the handset speaker so that they may be heard while dialing.

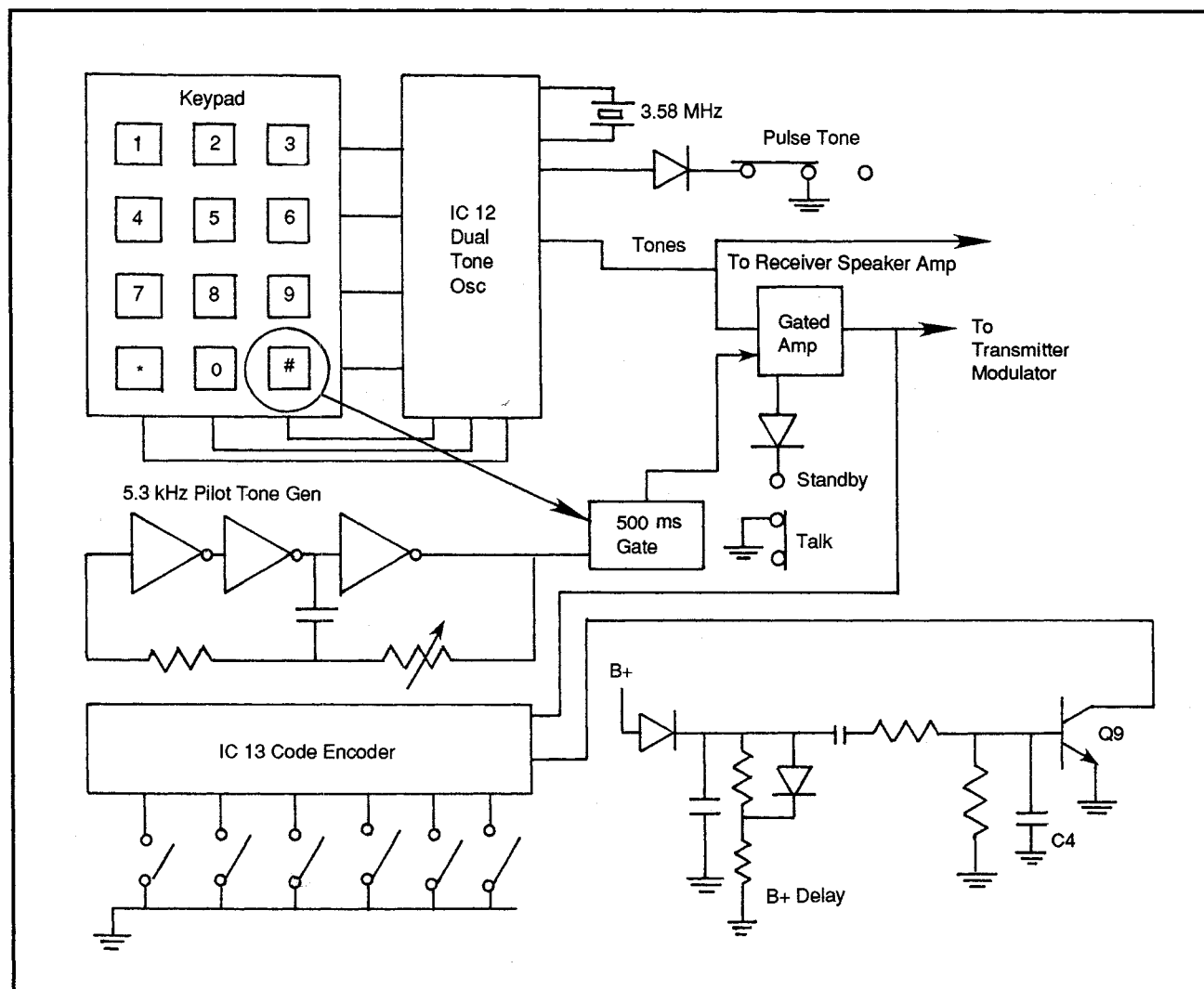


Figure 10: Dual tone, pilot tone and code generator

### B+ Delay

The B+ delay circuit shown in Figure 10 is used to delay the turn-on of the code encoder until the B+ has been applied to the transmitter and the 5.2 kHz pilot tone has been started. This delay allows the enabling of the flip-flop in the base unit, allowing this device to be set when the proper code is received.

The amplifier is gated off to reduce power consumption and to block the pilot tone until the switch is placed in the “talk” position. The output is fed to the transmitter modulator along with the output of the code encoder.

If the keypad is set to the pulse mode, pulses, not dual-tones, are sent to the gated

# 11/Tel Telephone

11/Tel - TR

Troubleshooting and Repair

11/Tel - TR - CP

Cordless Phones

11/Tel - TR - CP - D

Design

amplifier. These pulses gate the 5.3 kHz off and on to follow the dial pulses, triggering the base unit's line relay.

The 2.1 kHz call tone and the digital security code from IC-11 (see Figure 8) are used in the call signal circuit shown in Figure 11.

The security code is compared with the code switches. If the code is correct (matches), a high level signal is sent to the tone amplifier allowing the 2.1 kHz ring/page tone to pass to the tone detector. This detector is similar to the base unit detector IC-7 shown in Figure 6.

Note that the security/pilot tone system in the handset is more complicated than the one in the base unit. The reason is to prevent accidental — or purposeful — access to the base unit, and thus the telephone line, through another handset.

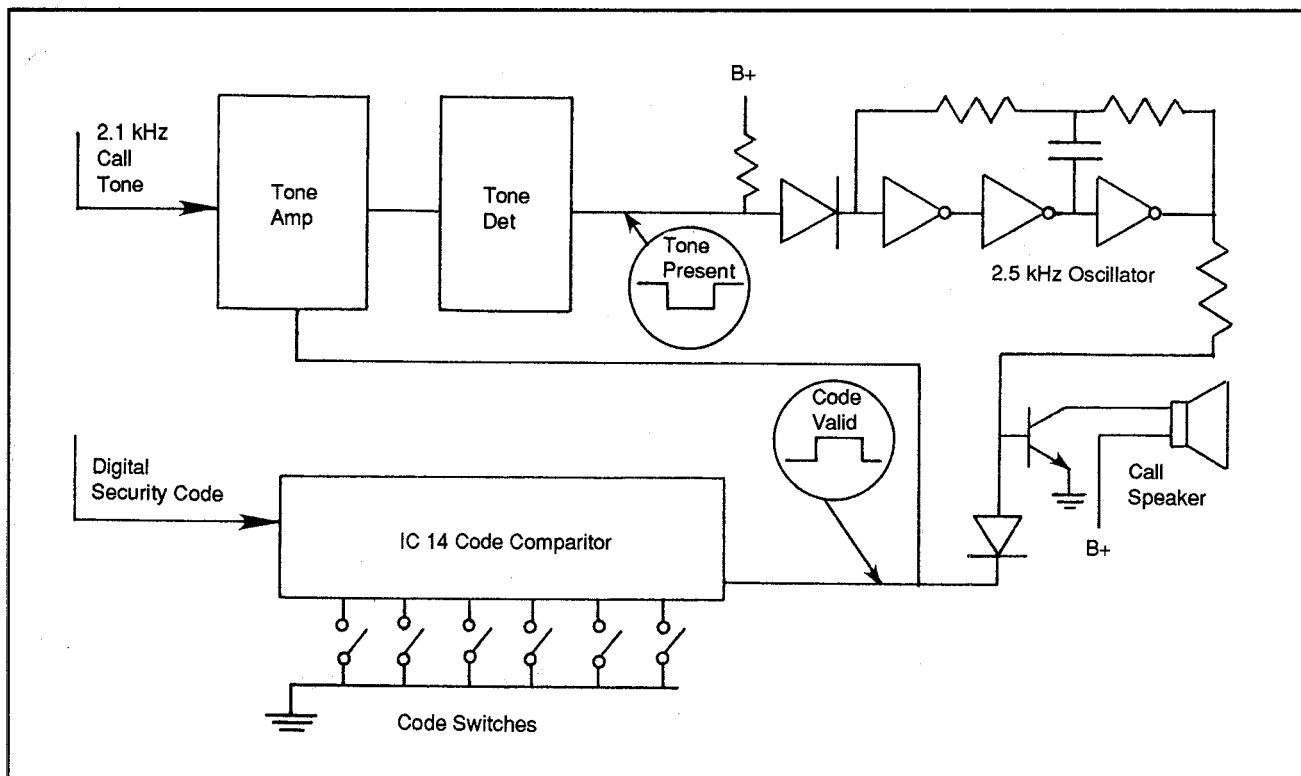


Figure 11: Handset call signal circuitry





11/Tel - TR	Troubleshooting and Repair
11/Tel - TR - CP	Cordless Phones
11/Tel - TR - CP - D	Design

### Troubleshooting Chart

Symptom	Comments	Refer To
Base unit dead	Check base power supply Check incoming power	Fig. 1
Handset not charging	Check base unit supply Check handset charging Check battery pack	Fig. 1 Fig. 1, 2
No ring	Check incoming line Check for B+ to transmitter Check for 2.1 kHz tone into modulator Test for constant tone into modulator Test for 2.1 kHz tone at output of IC-11 Test base transmitter Test handset receiver Test for high out of IC-14 Test for 2.5 kHz	Fig. 3 Fig. 4 Fig. 3, 4 Fig. 8 Fig. 4 Fig. 8 Fig. 11 Fig. 11
Line not seized	Test for 5.3 kHz pilot tone into modulator Test for 5.3 kHz pilot tone from IC-6 Test IC-13 output Test for low from IC-7 and IC-10; if both are present test for high from IC-8 and low from IC-9 If IC-8 is high and IC-9 is low, test for high from IC-5 and operation of line relay by Q5	Fig. 10 Fig. 5 Fig. 10 Fig. 6  Fig. 3
No voice from handset	Test microphone and audio amp	Fig. 9
No tone from keypad	Check DTMF from IC-12; check tones into transmit modulator Check tones out of IC-6; if not present, check handset transmitter and base RF Check tones through hybrid and line relay	Fig. 10 Fig. 5  Fig. 3
No voice to handset	Test for voice signals from hybrid through transmit amplifier Test for voice signals from IC-12 through volume switch, gated audio amp and speaker	Fig. 3, 4 Fig. 8
# button (flash) drops line	Test for momentary + pulse at output of IC-7 when # is pressed; check IC-8 and if low check delay circuits (R6, R7, C3 and D4) Test for dropout of B+ to transmitter Check delay circuit	Fig. 6  Fig. 3



---

11/Tel - TR	Troubleshooting and Repair
11/Tel - TR - CP	Cordless Phones
11/Tel - TR - CP - D	Design

---

11/Tel - TR	Troubleshooting and Repair
11/Tel - TR - SP	Standard Phones

## 11/Tel - TR

### Troubleshooting and Repair

## 11/Tel - TR - SP

### Standard Phones

Phones come in many styles, shapes, colors, and degrees of complexity. A touch-tone phone is more electronically complex than a rotary-dial phone. However, a rotary dial phone (older model) is more mechanically complex.

If after testing all the house lines and determining the phone is at fault, it is time to open the phone and begin work. First you have to decide whether it would be cheaper to replace the ten dollar phone rather than spend the time to troubleshoot and repair it.

#### Phone Cords

The first items to check (after it has been determined the house wiring is OK) are the phone cords. Most phone cords today are easy to check. As always, this begins with a visual examination. Then, simply unplug the modular cord and replace the cord with another. If you don't have a spare cable, you can check each wire for continuity with a DMM.

Handset cords and wall plug cords are not the same (assuming the phone is a two-piece model). The plugs on the two cords are different sizes. Although the two can be forced to make marginal contact even if mismatched, it is best to use the proper cords for the handset and the base.

#### Handset

In the handset of Figure 3 in Section "*11/Tel - A An Introduction*," very little can go wrong. Either all the wires and connections are good, or they are not. Checking the operation of a handset is straight forward. Pick up the handset and listen. If there is sound and the other party can hear your voice, it works fine. (Chances are, the slight and intentional feedback will allow you to hear your own voice.) If not, try a different handset of the same type to see if the problem is fixed. If so, the problem is in the handset, otherwise the problem is in the phone or phone line.

#### Tip

Using different handsets with different phones may or may not work. Older handsets employ the use of a carbon microphone. Newer handsets use dynamic microphones. The two are not interchangeable.

The wires running through the handset can be easily checked for continuity with a DMM. Open the handset by removing the receiver cap and the transmitter cap. (With some phones, the entire front of the handset is removed as a single piece.) Remove the transmitter (it will probably fall out upon opening the transmitter section). Inspect to see if the contacts are clean and are properly touching the transmitter. The transmitter depresses the spring-like connectors when normal. Make sure one connector touches the inside contact of the transmitter and the other touches the outside.

With a DMM, check to see if the contacts are connected to the outside wiring. Transmitter wires (or mike wires) are often color coded yellow and black. They will connect to the outer terminals of a receiver modular jack. Check for continuity from each pin to its corresponding wire.

The receiver wires will be red and green and connected to the two inner terminals of a modular jack. Check each for continuity. With some receivers (speakers) there may be a resistance value read when checking the wires. This occurs when checking the green wire and the red terminal connection.

### Rotary Dial

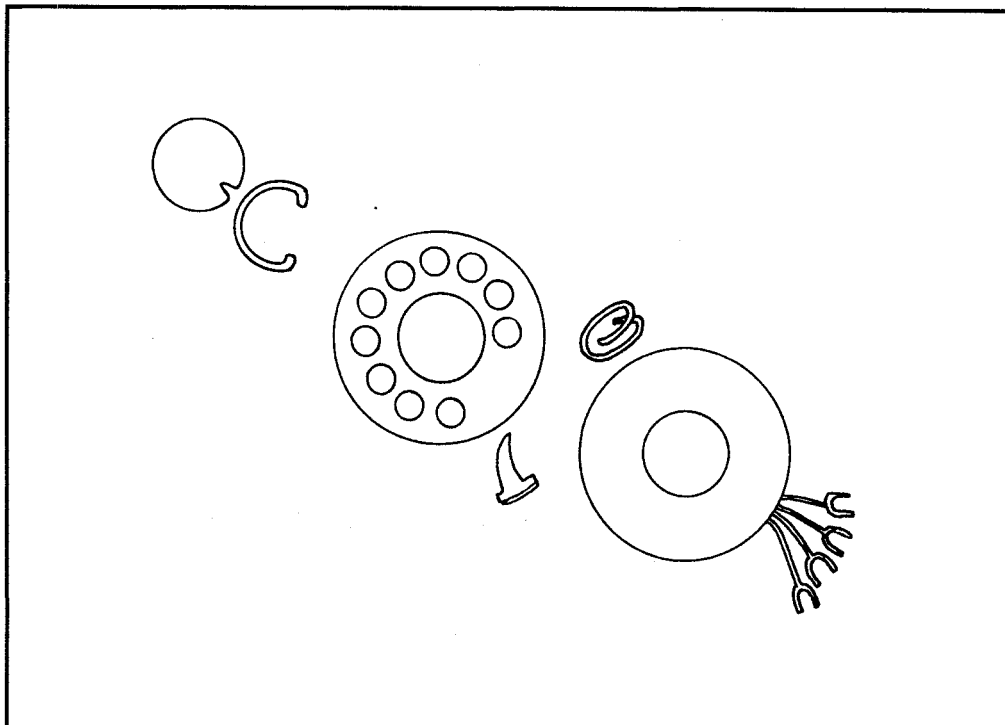
Figure 1 shows an exploded view of a typical rotary dial. The rotary dial is a mechanical device that requires little maintenance. As a number is dialed and then released, the rotary is returned to the rest position by a spring load. The contact spring assembly is open and closed as the rotary closes, pulsing the number.

If any part of the assembly becomes worn or broken, it could prevent proper rotation of the rotary system. Begin by thoroughly cleaning the parts. If this doesn't solve the problem, or if there is obvious damage, the defective part should be replaced (usually from a compatible replacement). Since replacement parts are usually scavenged from other old phones, care must be taken that the parts are compatible, and that they aren't in worse condition than the parts they are replacing.

### Touch Tone Dial

Touch-tone dial modules are simply a collection of buttons that open and close a circuit to create a combination of tones. If these contacts become dirty or shorted, proper operation of the keypad will not work. Opening the phone and cleaning contacts will usually correct the problem.

Older-touch tone modules are spring loaded and may be difficult to reassemble. Many newer touch tones use "pop" circuits. The contacts are conductive soft material in a non-conductive membrane. When these come in contact with a PC board, a circuit is closed. Figure 2 shows a circuit diagram for a typical touch-tone dial.



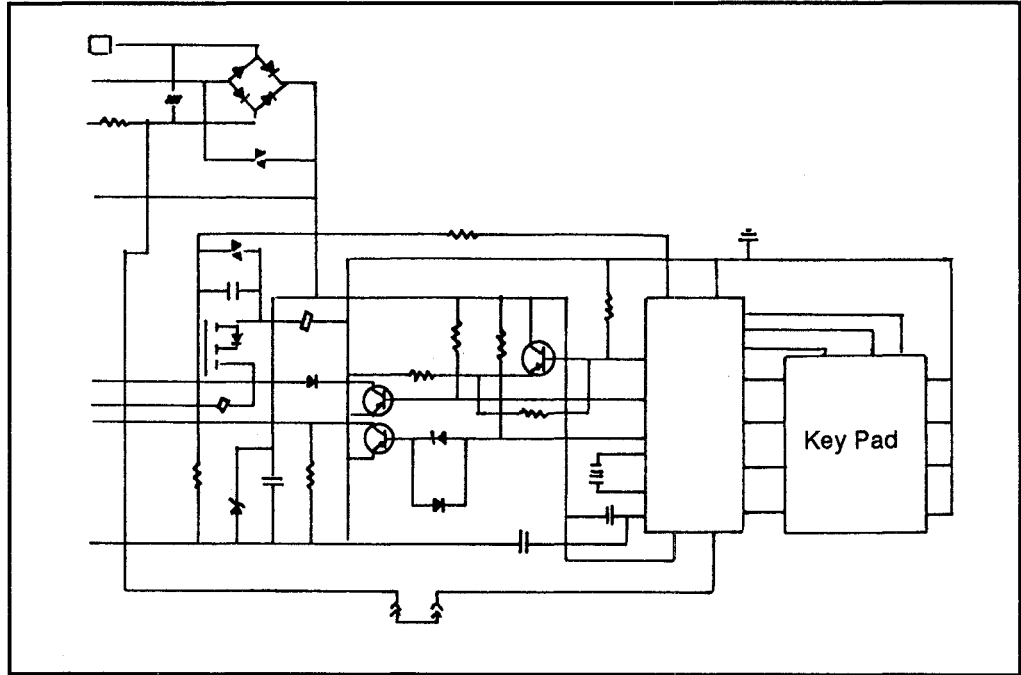
**Figure 1:** Exploded view of a rotary dial

### Networks

Networks are used in older rotary dial and tone dial phones. Newer phones use complete PC board mounted components and do not need this kind of network. Figure 3 shows a telephone network and its related circuit layout. The network contains most of the required components needed to make a phone operate. These are simple discrete components like capacitors, resistors, diodes and transformers that can be individually checked. Figure 4 shows an older style box-type telephone network.

### Ringers, Buzzers and Bells

Telephone ringers have developed from the older single or dual bell system, to the coil-driven buzzer, to the newer electronic chipper (ringer). In all cases, the ring voltage is applied (directly or indirectly) to the assembly which brings about the appropriate sound(s). In older units, the voltage will usually be applied to a coil. In newer units the voltage will go to a circuit or IC chip (or a portion of an IC chip). In the latter case, it may also go through a circuit to reduce the voltage. In older telephones with separate ringing devices, tracing the wires is simple because the components, including the bell or buzzer, are discrete. In such cases testing is nothing more than using a DMM to test for current going to the ringer/buzzer. If it is getting current but is not working, it needs to be replaced. If no current is getting to it, the problem is elsewhere.



**Figure 2:** Touch tone phone diagram

For newer telephones, the ringer is more likely to be an IC, or within an IC connected to a piezo sound element. To identify the component you will often need the exact manual for the unit (if one is available). Lacking this, one way to trace it is to follow the contacts from the ringer volume control. At least one leg of this, and sometimes both, will be between the ringing device and the speaker. Once you have found the correct leads, these can be tested with the DMM in much the same way you'd test discrete components. If voltage goes to the device, and if signals come out of the device, chances are good that the device is okay. Test the speaker by injecting a low-power signal to it. A sound should be heard, or clicking.

Many tone ringers can be found to replace the bulky bell assembly of a telephone. These provide the same function and performance under a variety of conditions. The tone ringers must meet FCC and EIA-470 regulations. All that is required by these is that the ringer circuit must function when a ringing signal is provided and not function when other signals are present (speech, dialing, or noise).

Some various tone-ringer ICs are available which require very little external connections other than connecting to the phone line and the speaker. Figure 5

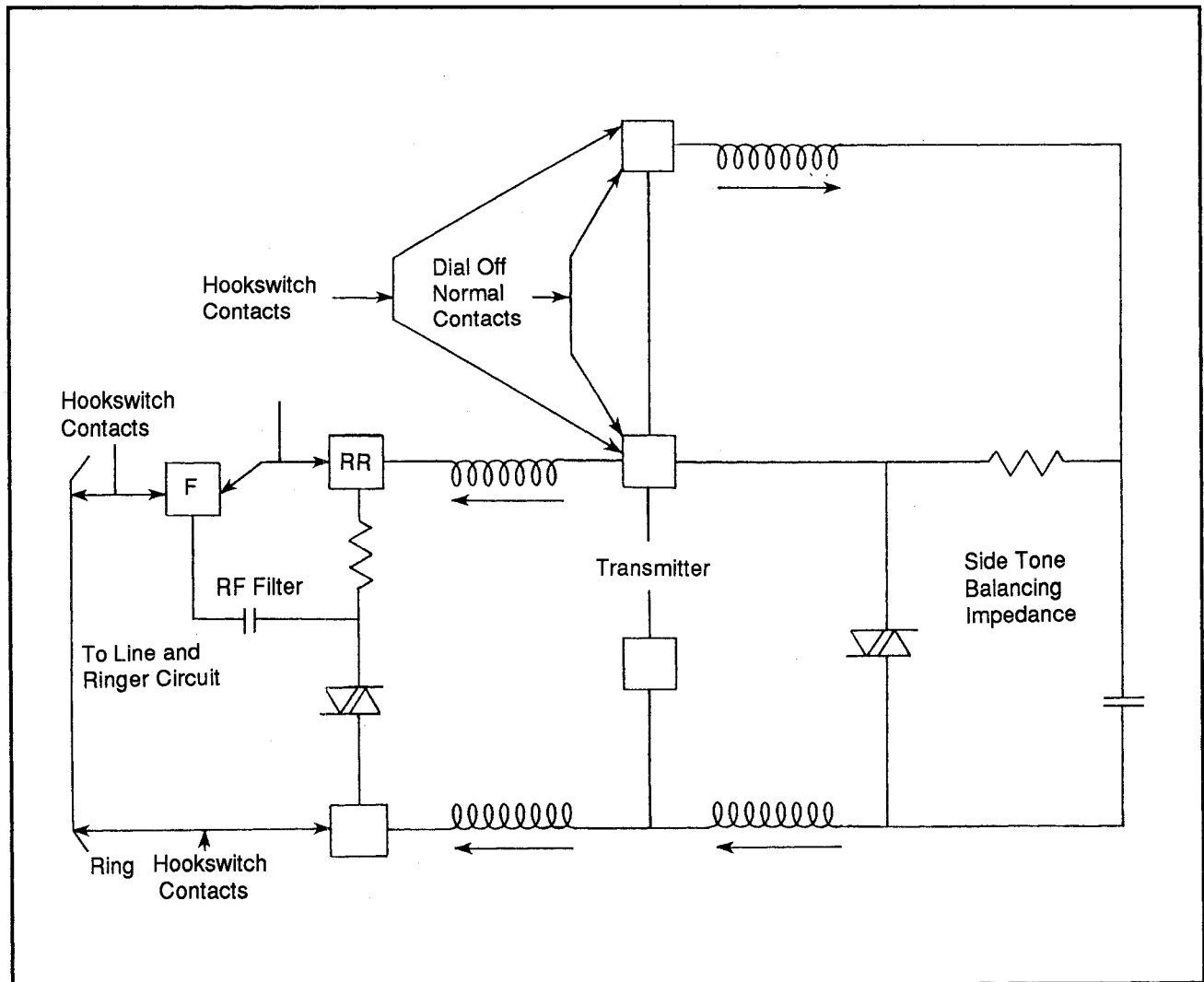
**11/Tel**  
Telephone

11/Tel - TR

Troubleshooting and Repair

11/Tel - TR - SP

Standard Phones

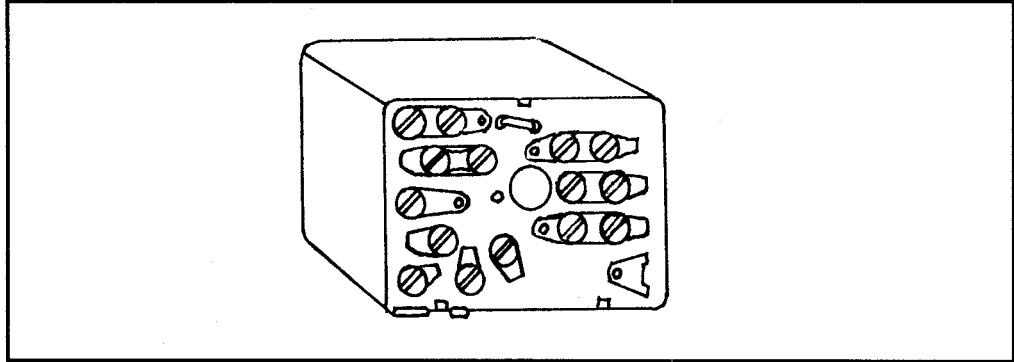


**Figure 3:** Telephone network and related schematic

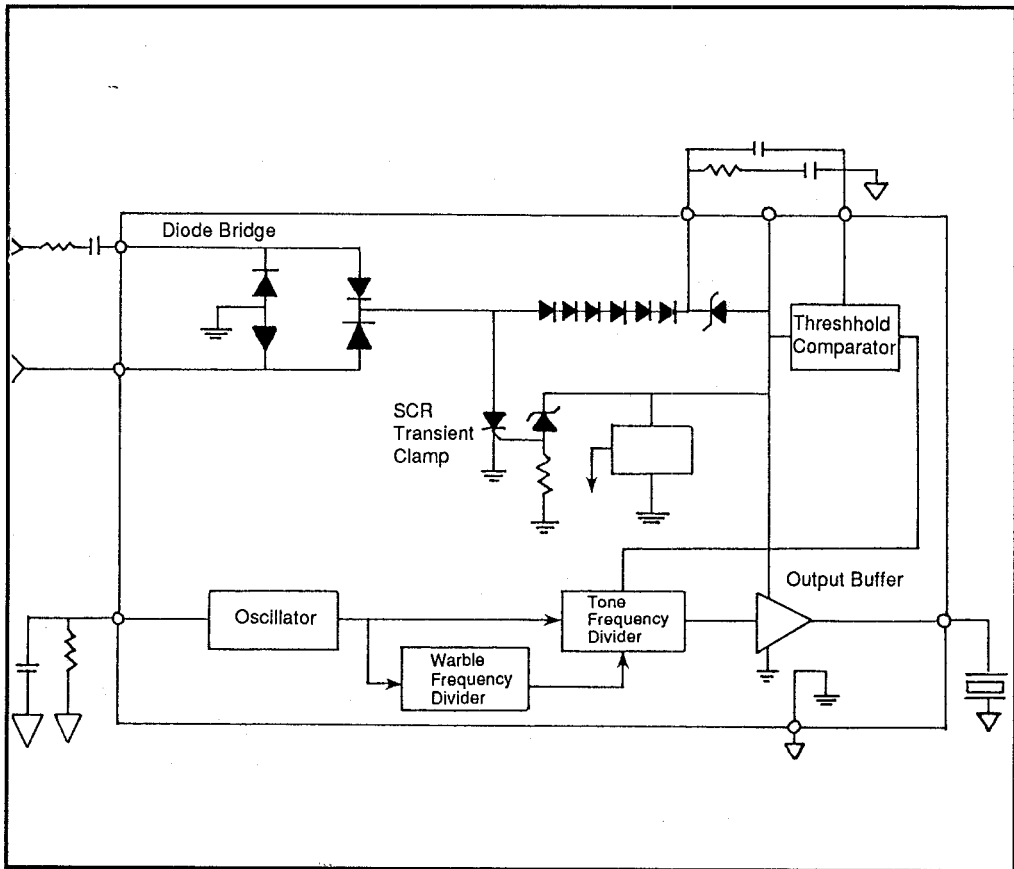
shows an MC34012 telephone ringer connection. This chip is a complete telephone bell replacement and has all the necessary internal components required to sense when a ringing voltage has occurred. The output is connected to a piezo sound element which then gives a pleasant electronic chirping when a call is received. The output can be set to warble at different ratios to the user's liking.

**Simple Electronic Phone**

The simplest electronic phone that can be purchased today can employ as few as one IC to operate, but more often two or more. There will be a few discrete



**Figure 4:** Older style box-type telephone network



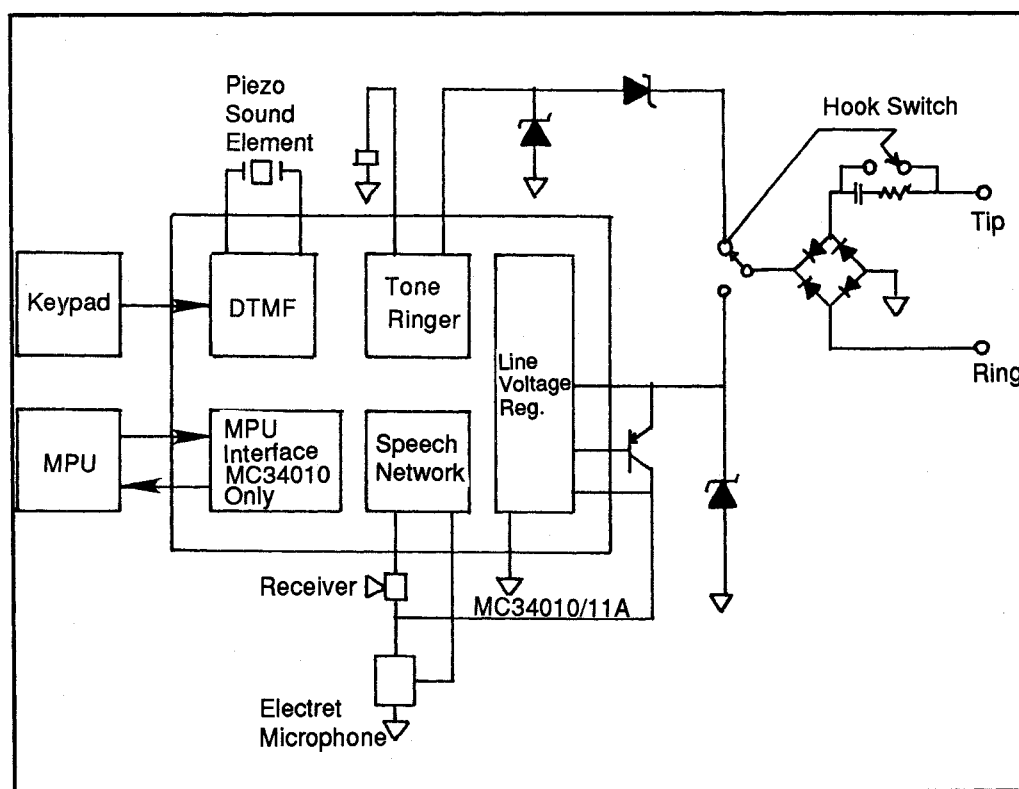
**Figure 5:** MC34012 telephone ringer replacement IC

components (various diodes, resistors and capacitors) all of which will connect in some way to the main IC. The main IC is in itself a complete electronic telephone circuit. An additional IC may be used for functions such as a



microprocessing unit for control of automatic dialing procedures. Such a simplified phone is shown in Figure 6.

This technology is completely compatible with existing phone systems and can be found in many low-cost touch-tone phones. Repairing such a phone would require the ability to replace the IC (which is impractical both because the chip is hard-soldered to the PC board and because the replacement chip will be difficult to find, and probably as expensive as a new phone) or replacing the phone. If all connections to and from the IC seem to be OK, the IC may be bad and the phone should be discarded. If the problem is determined to be in one of the discrete components, replace the component and check the operation of the phone.



**Figure 6:** The complete, simplified electronic telephone



---

11/Tel - TR

Troubleshooting and Repair

---

11/Tel - TR - SP

Standard Phones

---

# 11/Tel Telephone

11/Tel - TR

Troubleshooting and Repair

11/Tel - TR - TL

Telephone Line

## 11/Tel - TR Troubleshooting and Repair

### 11/Tel - TR - TL Telephone Line

Phone problems don't always occur in the phone or even in the household line. Most problems are due to problems in the outside phone line. The reason is simple. The lines in your home are fairly well protected from the elements. The outside lines that carry the signals are exposed to all sorts of conditions. Even lines buried in the ground have to contend with the natural corrosive effect of earth, with burrowing animals, etc.

There isn't anything you can do about the outside lines. It's not legal for you to try. Any of the equipment owned by the phone company is not to be touched. Failure to heed this can put you in serious danger.

Even so, it helps to have some understanding of the symptoms common with outside lines as this will help you to determine if the problem is located in your home.

#### Testing

Unplug everything and then use a phone you know to be good to test each outlet. You may also be able to test at the service access box, which will quickly point out if the problem is inside or outside the home.

#### Intermittent Problem

Intermittent problems are more difficult to diagnose. This could be caused by something in the home, or an intermittent short or open in the outside line, the service post or elsewhere in the outside system.

#### Crackling/Static

Crackling or static in the background are usually caused at the tie point on the pole to your house, or at the post if there is no pole. Connections break down and tend to spark by making open and closed connections. For buried cables, the problem could be caused by a nick in the wire, or just corrosion from age, which allows water to bring on the intermittent shorts or opens.

These are problems the phone company must take care of. Again, you cannot legally touch lines or equipment owned by the telephone company.

# 11/Tel

## Telephone

11/Tel - TR

Troubleshooting and Repair

11/Tel - TR - TL

Telephone Line

### Automatic Test Equipment

Telephone companies use automatic testing equipment to monitor telephone lines within the central office. If at any point a telephone line pair develops a problem, the pair at fault can often be disconnected and rerouted. The circuit will then be corrected by a service technician and repaired. It is possible that the phone company knows about problems with your line that you do not.

### Corrosion

Corroded pins on the modular connector can also cause a problem. For example, when voltage from an incoming call reaches this corrosion, the voltage can jump across the pins within the connector, disconnecting the call.

### Damaged Wires

A fairly common problem is when the wires in the home have been chewed by an animal, or have been otherwise damaged. Inspection of the lines inside the walls is often difficult and is sometimes impossible. Testing, however, is fairly simple if you have the proper equipment.

### Testing the Wire

Your goal is essentially to test each wire, and each wire pair, for continuity. Because of the length of the wires, something must be on one end injecting a signal, with a probe or other test device used at each junction box inside. This will tell you quickly if there is a break, and where that break is located. For example, if you inject a signal on the yellow wire, and find this signal at the first and second outlets but not at the third, you know that the break is between the second and third outlets.

### Symptoms

There are certain symptoms that can help guide you to discovering what has gone wrong. Note that these symptoms will occur regardless of where the problem is. That is, the symptoms of an open circuit will be the same if the cause is a particular telephone, the pedestal or a main trunk line.

### Open Circuit

An open circuit shows that one or more wires are not making contact. This can be caused by a break, by corrosion or by a faulty connection. This may happen to both wires or to either individual wire. In general an open circuit is detected by a lack of voltage (and thus lack of operation) in the home equipment.

If both wires are open inside the phone, there will be a dial tone and line voltage on the telephone company side but none on the home equipment side. You won't hear a dial tone, and probing the wires/contacts of the telephone with the DMM will give no reading. In other words, the telephone will be completely dead. If only the ring wire is open, there will be no dial tone. You may be able to use the phone, but there will be a loud humming on the line. To test, hook the leads of the test phone between the tip wire and ground, thus bypassing the ring wire. You should now get a clear dial tone. If you don't, the tip wire is open. (If the tip wire is open, you will be unable to read any line voltage.)

As above, track the problem backwards. If it is occurring at one outlet but not another earlier in the system, you know that the open is between those two.

If you suspect that the open circuit is in a particular telephone, the easiest test is to unplug that phone and try another you know to be good in that outlet. If the problem clears, the open is in the telephone. If it doesn't clear, the error is in the wiring.

If the problem is in the telephone, open the phone and visually examine the wires and connectors. If you can't spot the source of the problem you can inject a signal where the wires enter the phone and probe other spots to find out where the open has occurred. For example, if you inject a signal and also find that signal at the handset connector, the problem is in the handset or its cord. If the signal is not present at this connector, the problem is inside the phone. (This can be done without even opening the telephone.)

### Grounded Circuit

A grounded circuit happens when one of the two wires is shorted to ground. The exact symptoms will tell which wire is grounded. One problem you encounter, however, is that if there is a grounded wire inside the telephone, the entire circuit (outside the telephone) will be affected. It's entirely possible that this will be detected by the phone company with the result being a disconnection of service until the problem is fixed.

If both wires are grounded (rare), the phone will be completely dead. This is because all signals, including line voltage, are going directly to ground. If you measure the two wires with the DMM you will find indication of a dead short between the two wires.

If just the ring wire is grounded, you will hear a busy signal masked over by loud humming and static. A test for voltage across the two wires will show a low line voltage.

When just the tip wire is grounded, you will hear a dial tone, again covered over with heavy static and humming. You may be able to dial out but talking will be difficult or impossible.

### Phone Goes Dead or Disconnects

If the phone goes dead, or is intermittent, it is possible there is a bad cord connecting to the phone. The cord may be damaged, or of the wrong kind. Using a handset cord as the wall-to-phone cord can cause intermittent phone operation simply because the connector doesn't fit. Both have their wire terminals spaced the same, but the width of the housing for each is different. A bad cord may mean

# 11/Tel

## Telephone

11/Tel - TR	Troubleshooting and Repair
11/Tel - TR - TL	Telephone Line

one of the pairs (tip or ring) is broken. Changing the cord is the easiest method to determine this.

The modular plug, or hardwired plug, may have a loose connection internally. Most of these cannot be opened. Both testing and fixing is by replacement. Modular wall sockets have wires that lead to terminal blocks and it could be that the screws on the terminal block are loose. Open and inspect the wall telephone socket for loose or corroded terminal connections.

As a note on this, many “home installers” will connect only two of the four wires, since only two are needed, and leave the other two unconnected. Finding this condition does not necessarily mean that you have found the problem, only that the installer took a “short cut”.

In general, this practice will affect the system only if the original pair has been damaged and is switched for the second pair. If this is done, and that second pair isn’t connected to anything in the outlet, obviously the phone won’t work until you open the outlet and connect the wires.

### Noise on the Line

A noisy line is usually caused by a wire making partial or complete contact with ground. This means that somewhere along the line a part of the insulation has been removed through age or damage. It’s not uncommon for such problems to occur only during rainy weather. If so, this generally indicates that the short is being caused by a partially degraded wire, or that dripping/running water is causing a short between a connector and ground.

Another possible cause of line noise is an appliance being operated near the phone or phone line. Some appliances generate low-grade RF noise which can be picked up by the wires. This is particularly true of cordless phones which, by their nature, work with RF signals. If appliance noise is the problem, it will disappear when the appliance is not in operation.

To determine if the hum comes from the home or from the phone company’s line, go to the customer access box. Open the box and unplug the modular jack for the phone line. If there are two lines, unplug both. (Figure 1 shows the internal design of a typical customer access box.) This is to be sure that the house is isolated and that the only signals present are from outside the home.

Plug a phone into the jack (or each jack) and see if the hum is still present. If so, it is the phone company’s problem. Replace the house modular connections, close the box and call the phone company.

# 11/Tel

## Telephone

11/Tel - TR	Troubleshooting and Repair
11/Tel - TR - TL	Telephone Line

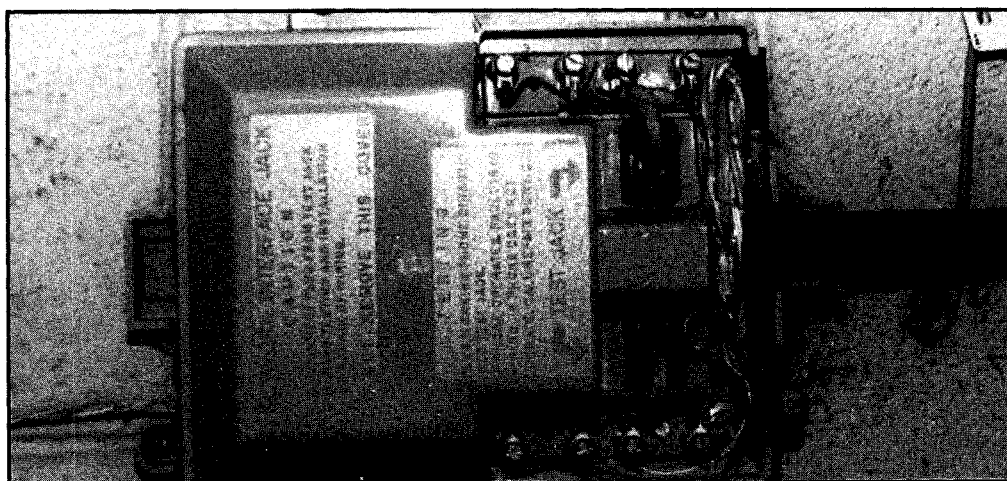
If the phone access box is of the older block type with terminal screws, remove the wires that feed the home. Connect a test phone to the red and green wires, or to the yellow and black wires when the spare pair is being used either for the main line or as a second line. The same procedure applies. If the hum is still present, the problem is the phone company's.

When the problem of humming is inside, your options are to repair the wire with the short to ground, use the spare pair, or replace the wiring - either between outlets or entirely (depending on where the problem is found).

Repairing the wire with the grounding problem, or replacing that section, requires that you trace the problem to a particular section. As above, this means tracing the wire from outlet to outlet until the problem section is found.

Obviously, using the second pair requires that this second pair isn't already in use. Also be warned that if there is only one pair in use, and it is the black and yellow pair, chances are good that the red/green pair already went bad at some earlier time. If so, you'll have no choice but to replace the cable (and find out why both pairs went bad). You will also have to go through the house, outlet by outlet, to be sure that the new pair is connected properly to the terminals.

**Crossed Telephone Circuit** Hearing other conversations on the line is a symptom of a crossed circuit. They may be very dim and distant, or could be loud enough that you can even talk to the other party. Such a symptom is always a problem within the phone company's wiring.



**Figure 1:** The inside of a typical customer access box



---

11/Tel - TR	Troubleshooting and Repair
11/Tel - TR - TL	Telephone Line

---

Crosstalk can also occur when the ground is wet after a heavy rain. If this occurs you may just have to wait for it to dry out. If it occurs frequently or is annoying, the phone company should be called to repair it.

They may not be willing to fix the problem if it happens only rarely. The reason for this isn't just lack of consideration. The more rare a problem is, the more difficult it is to track down. In this case, it is virtually impossible to find the source of crosstalk if it's not occurring right at the moment.

**Radio Signals  
Over the Phone**

A rare but sometimes annoying symptom is hearing a radio station on the line. This almost always means that there is an exceptionally strong radio station transmitting nearby, with the cable serving as a receiving antenna. The phone company may or may not cure the problem by installing a filter on the line.

**Dust, Debris and  
Webbing**

Spiders tend to enjoy finding small housings to fill with cobwebs. A telephone access box is an ideal place to find a collection of webbing. A buildup of webbing can cause a variety of problems, especially after moisture develops on the webs. This moisture will not only cause problems in itself, it will increase the rate of corrosion.

Much the same is true of other contaminants. Dust, dried leaves, grass, etc. can all find their way into the service access box.

The cure is regular inspection of the box. If the outside is filthy, you know that the inside probably is as well. Gently brush out the inside with a small (1" or 2") paint brush. If the problem persists or is regular, you might have to relocate the box so that it is better protected. (Check with the phone company as to their policies before doing this on your own.)



---

# Section 12

## Reference Materials

---

### Table of Contents

<b>12/A</b>	<i>Addresses</i>
<b>12/A - MA</b>	<i>Manufacturer Addresses</i>
<b>12/A - MA - EE</b>	<i>Electronic Equipment and Supplies</i>
<b>12/A - MA - TE</b>	<i>Test Equipment</i>
<b>12/A - MA - TV</b>	<i>TV Receivers and Monitors</i>
<b>12/A - MA - VP</b>	<i>Video Products</i>
<b>12/I</b>	<i>Indices</i>
<b>12/I - A</b>	<i>Abbreviations</i>
<b>12/I - IC</b>	<i>Integrated Circuits</i>
<b>12/I - IC - A</b>	<i>Audio Devices</i>
<b>12/I - PC</b>	<i>Personal Computers</i>
<b>12/I - PC - POST</b>	<i>POST Screen Error Messages</i>
<b>12/S</b>	<i>Schematics</i>
<b>12/S - Cam</b>	<i>Camcorders</i>
<b>12/S - Cam - Pan</b>	<i>Panasonic</i>
<b>12/S - Cam - Pan - PV-602, 4, 10</b>	<i>PV602, 4, 10</i>
<b>12/S - CD</b>	<i>Compact Disc Player</i>
<b>12/S - CD - Hi</b>	<i>Hitachi</i>
<b>12/S - CD - Hi-DA-C60</b>	<i>DA-C60</i>
<b>12/S - CT</b>	<i>Cordless Telephones</i>
<b>12/S - CT - Pan</b>	<i>Panasonic</i>
<b>12/S - CT - Pan - KX-T3000</b>	<i>KX-T3000</i>
<b>12/S - Tel</b>	<i>Telephones</i>
<b>12/S - Tel - Pan</b>	<i>Panasonic</i>
<b>12/S - Tel - Pan-KX-T1423/-T2325</b>	<i>KX-T1423/KX-T2325</i>

Table of Contents

---

---

---

---

12/S - TV	TVs	
12/S - TV - RCA	RCA	
12/S - TV - RCA - CTC140		CTC140
12/S - VCR	VCRs	
12/S - VCR - Hi	Hitachi	
12/S - VCR - HiVT-34A		VT-34A
12/S - VCR - Pan	Panasonic	
12/S - VCR - Pan - PV-4860, 2; VH5685		PV-4860, 2; VH5685
12/S - VCR - SO	Sony	
12/S - VCR - SO-VO-5800		VO-5800

Index

**12/A**  
**Addresses**

12/A - MA	Manufacturer Addresses
12/A - MA - EE	Electronic Equipment and Supplies

**12/A - MA**  
**Manufacturer Addresses**

**12/A - MA - EE**  
**Electronic Equipment and Supplies**

<p><b>AD ELECTRONICS</b> Blissfield, MI 1-800-843-6659</p> <p><b>ALMAC STROUM ELECTRONICS</b> Bellevue, WA 1-800-426-1410</p> <p><b>ALSTON ELECTRIC SUPPLY</b> Pensacola, FL 1-800-521-1043</p> <p><b>AMERICAN ANTENNA</b> Elgin, IL 1-800-323-5608</p> <p><b>AMERICAN DESIGN COMPONENTS</b> Moonachie, NJ 1-800-227-2185</p> <p><b>AMERICAN TECHNOLOGY LABS</b> Stevenville, MT 1-800-223-9758</p> <p><b>AZ-TECH ASSEMBLIES INC</b> TUCSON, AZ Georgetown, KY 1-800-624-4827</p> <p><b>B &amp; B INTERNATIONAL</b> <b>ELECTRONICS</b> Minneapolis, MN 1-800-826-7623</p> <p><b>CAPACITOR SALES</b> Sunnyvale, CA 1-800-538-8587</p>	<p><b>CIRCUIT SPECIALIST</b> <b>OF ARIZONA</b> P.O. Box 3047 Scottsdale, AZ 85271-3047 <b>WAREHOUSE</b> 220 S. Country Club Drive Mesa, AZ 85210 1-800-528-1417 Fax: 1-602-464-5824</p> <p><b>COMPUADD COMPUTER</b> <b>CORPORATION</b> 12303 Technology Blvd. Austin, Texas 78727 1-800-627-1967</p> <p><b>ELECTRONIC PRODUCT</b> <b>SALES</b> Dayton, OH 1-800-638-6558</p> <p><b>GOLDSTAR INTERNATIONAL</b> <b>ELECTRONICS</b> Lyndhurst, NJ 1-800-562-0244</p> <p><b>HARD DRIVE INTERNATIONAL</b> 1912 W. 4th St. Tempe, AZ 85281 1-800-767-3475 1-602-350-1128 Fax: 1-602-829-9193</p> <p><b>INSIGHT COMPUTERS</b> 1912 W. 4th St. Tempe, AZ 85281 1-800-767-7600 1-602-350-1176 Fax: 1-602-829-9193</p>	<p><b>PREMIUM PARTS PLUS</b> PO Box 28 Whitewater, WI 53190 1-800-558-9572</p> <p><b>MEGATRON ELECTRONICS</b> Irvine, CA 1-800-528-5014</p> <p><b>VACUUM TUBE INDUSTRIES</b> Brockton, MA 1-800-528-5014</p>
--	--	--

**12/A**  
**Addresses**

---

12/A - MA

Manufacturer Addresses

---

12/A - MA - EE

Electronic Equipment and Supplies

---

# 12/A

## Addresses

12/A - MA

Manufacturer Addresses

12/A - MA - TE

Test Equipment

## 12/A - MA

### Manufacturer Addresses

## 12/A - MA - TE

### Test Equipment

<p><b>AUDIO TEST ALIGNMENT AND MEASUREMENT</b></p> <p>AMBER ELECTRO DESIGN 6969 Trans-Canada Highway St. Laurent, Que. Canada H4T1V8 514-333-8748 800-361-3697</p> <p>ARIEL CORP. 433 River Road Highland Park, NJ 08904 201-249-2900 Fax: 201-249-2132</p> <p>AUDIO PRECISION P.O. Box 2209 Beaverton, OR 97075 503-627-0832 800-231-7350 Fax: 503-641-8906</p> <p>B &amp; B SYSTEMS, INC. 28111 N. Ave. Stanford Valencia, CA 91355 805-257-4853 800-345-1256 Fax: 805-257-8065</p> <p>B &amp; K PRECISION MAXTEC 6470 W. Cortland Chicago, Il 60635 312-889-1448 Fax: 312-794-9740</p>	<p>BOLAND COMMUNICATIONS 24386 Totuava Circle Mission Viejo, CA 92691 714-951-7557 Fax: 714-588-1070</p> <p>DELTA ELECTRONICS, INC. 5730 General Washington Drive Alexandria, VA 22312 703-354-3350 800-833-5828 Fax: 703-354-0216</p> <p>DORROUGH ELECTRONICS 160 First St. S.E. New Brighton, MN 55112-7894 612-633-1742 Fax: 612-633-7025</p> <p>FM SYSTEMS, INC. 3877 S. Main St. Santa Ana, CA 92707 714-979-3355 800-235-6960 Fax: 714-979-0913</p> <p>KAY ELEMETRICS CORP. P.O. Box 2025 Pine Brook, NJ 07058 201-227-2000 Fax: 201-227-7760</p> <p>MARCONI INSTRUMENTS, INC. 3 Pearl Court Allendale, NJ 07401 201-934-9050</p>	<p>MULTIDYNE ELECTRONICS, INC. 244 Bayville Ave. Bayville, NY 11709 516-628-1495 800-765-8200 Fax: 516-628-1496</p> <p>NEUTRIK USA, INC. 195-S5 Lehigh Ave. Lakewood, NJ 08701 908-901-9488 Fax: 908-901-9608</p> <p>SENNHEISER ELECTRONIC CORP. P.O. Box 987 Old Lyme, CT 06371 203-434-9190 Fax: 203-434-1759</p> <p>TEKTRONIX P.O. Box 500, M/S 58-699 Beaverton, OR 97077 503-627-4486 Fax: 503-627-4486</p> <p>TENTEL CORP. 4475 Golden Foothill Parkway El Dorado Hills, CA 95630 916-939-4005 800-538-6894 Fax: 916-939-4114</p>
---	---	---

# 12/A

## Addresses

12/A - MA

Manufacturer Addresses

12/A - MA - TE

Test Equipment

<p><b>AUDIO SIGNAL GENERATORS</b></p> <p>AMBER ELECTRO DESIGN 6969 Trans-Canada Highway St. Laurent, Que. Canada H4T1V8 514-333-8748 800-361-3697</p> <p>ASACA/SIBASOKU CORP. 12509 Beatrice Los Angeles, CA 90066 213-827-7144 Fax: 213-306-1382</p> <p>AUDIO PRECISION P.O. Box 2209 Beaverton, OR 97075 503-627-0832 800-231-7350 Fax: 503-641-8906</p> <p>B &amp; K PRECISION MAXTEC INTERNATIONAL PRODUCTS DIV. 6470 W. Cortland Chicago, IL 60635 312-889-1448 Fax: 312-794-9740</p> <p>BECKMAN INDUSTRIAL CORP. INSTRUMENTATION PRODUCTS DIV. 3883 Ruffin Road San Diego, CA 92123 619-495-3200 800-854-2708 Fax: 619-268-0172</p> <p>RICHARD W. BURDEN ASSOCIATES 20944 Sherman Way Canoga Park, CA 91303 818-340-4590</p> <p>DBX, A DIV. OF AKG ACOUSTICS, INC. 1525 Alvarado St. San Leandro, CA 94577 510-351-3500 800-243-7885 Fax: 510-351-0500</p>	<p>DELTA ELECTRONICS, INC. 5730 General Washington Drive Alexandria, VA 22312 703-354-3350 800-833-5828 Fax: 703-354-0216</p> <p>LEADER INSTRUMENTS CORP. 380 Oser Ave. Hauppauge, NY 11788 516-231-6900 800-645-5104 Fax: 516-231-5295</p> <p>LEITCH INC. 825-K Greenbrier Circle Chesapeake, VA 23320 804-424-7920 800-231-9673 Fax: 804-424-0639</p> <p>NEUTRIK USA, INC. 195-S5 Lehigh Ave. Lakewood, NJ 08701 908-901-9488 Fax: 908-901-9608</p> <p>SENNHEISER ELECTRONIC CORP. P.O. Box 987 Old Lyme, CT 06371 203-434-9190 Fax: 203-434-1759</p> <p>TEKTRONIX P.O. Box 500, M/S 58-699 Beaverton, OR 97077 503-627-4486 Fax: 503-627-4486</p> <p>VIDEOTEK INC. 243 Shoemaker Road Pottstown, PA 19464 215-327-2292 Fax: 215-327-9295</p> <p><b>AUDIO TAPE, TEST &amp; ALIGNMENT</b></p> <p>FIDELIPAC CORP. P.O. Box 808 Moorestown, NJ 08057 609-235-3900 Fax: 609-235-7779</p>	<p>GENEVA GROUP OF COMPANIES, INC. 9909 S. Shore Drive Plymouth, MN 55441 612-546-5620 800-328-6795 Ext. 382 Fax: 612-546-0933</p> <p>NEUTRIK USA, INC. 195-S5 Lehigh Ave. Lakewood, NJ 08701 908-901-9488 Fax: 908-901-9608</p> <p><b>TENSION GAUGES</b></p> <p>TENTEL CORP. 4475 Golden Foothill Parkway El Dorado Hills, CA 95630 916-939-4005 800-538-6894 Fax: 916-939-4114</p> <p><b>TEST EQUIPMENT — MISCELLANEOUS</b></p> <p><b>OSCILLOSCOPES</b></p> <p>B &amp; K PRECISION MAXTEC 6470 W. Cortland Chicago, IL 60635 312-889-1448 Fax: 312-794-9740</p> <p>Leader Instruments Corp. 380 Oser Ave. Hauppauge, NY 11788 516-231-6900 800-645-5104 Fax: 516-231-5295</p> <p>RISER-BOND INSTRUMENTS 5101 N. 57th St. Lincoln, NE 68507 402-466-0933 800-688-8377 Fax: 402-466-0967</p> <p>SENCORE ELECTRONICS 3200 Sencore Drive Sioux Falls, SD 57107 605-339-0100 Fax: 605-335-6379</p>
--	--	---

# 12/A

## Addresses

12/A - MA

Manufacturer Addresses

12/A - MA - TE

Test Equipment

**TEKTRONIX**  
P.O. Box 500, M/S 58-699  
Beaverton, OR 97077  
503-627-4486  
Fax: 503-627-4486

**TOOLS**

**BECKMAN INDUSTRIAL CORP.**  
INSTRUMENTATION PRODUCTS  
DIV.  
3883 Ruffin Road  
San Diego, CA 92123  
619-495-3200  
800-854-2708  
Fax: 619-268-0172

**CAIG LABS, INC.**  
16744 W. Bernardo Drive  
San Diego, CA 92127  
619-451-1799  
Fax: 619-451-2799

**CIRCUIT SPECIALIST, INC.**  
P.O. Box 3047  
Scottsdale AZ 85271-3047  
WAREHOUSE  
220 S. Country Club Drive  
Mesa, AZ 85210  
1-800-528-1417  
Fax: 1-602-464-5824

**CONTACT EAST**  
335 Willow St. S.  
North Andover, MA 01845  
508-682-2000  
800-225-5370  
Fax: 508-688-7829

**GC-THORSEN**  
P.O. Box 1209  
Rockford, IL 61105-1209  
815-968-9661  
800-435-2931  
Fax: 800-527-3436

**JENSEN TOOLS, INC.**  
7815 S. 46th St.  
Phoenix, AZ 85044-5399

**MATH ASSOCIATES, INC.**  
2200 Shames Drive  
Westbury, NY 11590  
516-334-6800  
Fax: 516-334-6473

**MERIDIAN TECHNOLOGIES**  
80 Mott Ave.  
Inwood, NY 11696  
516-371-9300  
Fax: 516-371-9301

**OPTICAL DISC CORP.**  
12150 Mora Drive  
Santa Fe Springs, CA 90670  
213-946-3050  
Fax: 213-946-6030

**TROMPETER ELECTRONICS, INC.**  
P.O. Box 5069  
Westlake Village, CA 91362-4047  
818-707-2020  
Fax: 818-706-1040

**VIDEO SIGNAL GENERATORS**

**ASACA/SIBASOKU CORP.**  
12509 Beatrice  
Los Angeles, CA 90066  
213-827-7144  
Fax: 213-306-1382

**B & K PRECISION MAXTEC**  
INTERNATIONAL PRODUCTS DIV.  
6470 W. Cortland  
Chicago, IL 60635  
312-889-1448  
Fax: 312-794-9740

**BECKMAN INDUSTRIAL CORP.**  
INSTRUMENTATION PRODUCTS  
DIV.  
3883 Ruffin Road  
San Diego, CA 92123  
619-495-3200

**BPI/PORTA-PATTERN**  
15755 South 169 Highway  
Olathe, KS 66062  
913-780-4844  
Fax: 913-780-5148

**COLORADO VIDEO INC.**  
P.O. Box 928  
Boulder, CO 80306  
303-530-9580  
Fax: 303-530-9569

**DIGITAL PROCESSING SYSTEMS**  
55 Nugget Ave., Unit 10  
Scarborough, Ont.  
Canada M1S 3L1  
416-754-8090

**ENSEMBLE DESIGNS**  
P.O. Box 993  
Grass Valley, CA 95945  
916-478-1830  
Fax: 916-478-1832

**FOR.A CORP. OF AMERICA**  
313 Speen St.  
Natick, MA 01760  
508-650-3902  
800-822-3672  
Fax: 508-651-8729

**GASLIGHT VIDEO**  
630 N. Tustin St., Suite 1516  
Orange, CA 92667-7100  
714-744-4190  
Fax: 714-744-1729

**HORITA**  
P.O. Box 3993  
Mission Viejo, CA 92690  
714-489-0240

**LEADER INSTRUMENTS CORP.**  
380 Oser Ave.  
Hauppauge, NY 11788  
516-231-6900  
800-645-5140  
Fax: 516-231-5295

**LEITCH INC.**  
825-K Greenbrier Circle  
Chesapeake, VA 23320  
804-424-7920  
800-231-9673  
Fax: 804-424-0639

**LENCO ELECTRONICS, INC.**  
753 Enterprise St.  
Cape Girardeau, MO 63701  
314-334-4433

**MAGNI SYSTEMS, INC.**  
9500 S.W. Gemini Drive  
Beaverton, OR 97005  
503-626-8400  
800-624-6465  
Fax: 503-626-6225

**MARCONI INSTRUMENTS INC.**  
3 Pearl Court  
Allendale, NJ 07401  
201-934-9050

**12/A**  
**Addresses**

12/A - MA

Manufacturer Addresses

12/A - MA - TE

Test Equipment

MULTIDYNE ELECTRONICS INC.  
244 Bayville Ave.  
Bayville, NY 11709  
516-628-1495  
800-765-8200  
Fax: 516-628-1496

NETWORK TECHNOLOGIES INC.  
7322 Pettibone Road  
Chagrin Falls, OH 44022  
216-543-1646  
800-742-8324  
Fax: 216-543-5423

OPTICAL DISC CORP.  
12150 Mora Drive  
Santa Fe Springs, CA 90670  
213-946-3050  
Fax: 213-946-6030

SENCORE ELECTRONICS  
3200 Sencore Drive  
Sioux Falls, SD 57107  
605-339-0100  
Fax: 605-335-6379

TEKTRONIX  
P.O. Box 500, M/S 58-699  
Beaverton, OR 97077  
503-627-4486  
Fax: 503-627-4486

VIDEOTEK INC.  
243 Shoemaker Road  
Pottstown, PA 19464  
215-327-2292  
Fax: 215-327-9295



**12/A  
Addresses**

12/A - MA

Manufacturer Addresses

12/A - MA - TV

TV Receivers and Monitors

**12/A - MA  
Manufacturer Addresses**

**12/A - MA - TV  
TV Receivers and Monitors**

<p><b>INSTANT REPLAY</b> 2601 S. Bayshore Drive, Suite 1050 Coconut Grove, FL 33133 305-854-8777 800-749-8779 Fax: 305-858-9053</p>	<p><b>JVC CORPORATION SOUTHWEST BRANCH</b> 407 Garden Oaks Blvd. Houston, TX 77018 713-694-0666 1-800-231-6839</p>	<p><b>SONY BUSINESS &amp; PROFESSIONAL GROUP</b> 1600 Queen Anne Road Teaneck, NJ 07666 201-833-5200 800-635-7669</p>
<p><b>JVC PROFESSIONAL PRODUCTS CO.</b> 41 Slater Drive Elmwood Park, NJ 07407 201-794-3900 Fax: 201-523-2077</p>	<p><b>mitsubishi ELECTONICS AMERICA, PRO ELECTRONICS DIV.</b> 800 Cottontail Lane Somerset, NJ 08873-6759 908-563-9889 800-733-8439 Fax: 908-563-0713</p>	<p><b>TOSHIBA VIDEO SYSTEMS DIV. TACP</b> 82 Totowa Road Wayne, NJ 07470 201-628-8000 Fax: 201-628-8755</p>
<p><b>JVC CORPORATION EAST COAST</b> I-80 at New Maple Ave. Pinebrook, NJ 07058 201-882-0900 1-800-247-3608</p>	<p><b>NEC TECHNOLOGIES INC. PROFESSIONAL SYSTEMS DIV.</b> 1255 Michael Drive Wood Dale, IL 60191-1094 708-860-9500 800-366-3632 Fax: 708-860-5812</p>	<p><b>VIDEOTEK INC.</b> 243 Shoemaker Road Pottstown, PA 19464 215-327-2292 Fax: 215-327-9295</p>
<p><b>JVC CORPORATION WEST COAST</b> 1111 West Artesia Blvd. Compton, CA 90220 213- 537-6020 1-800-421-6991</p>	<p><b>PANASONIC COMMUNICATIONS &amp; SYSTEMS CO.</b> One Panasonic Way Secaucus, NJ 07094 201-348-7671 800-524-0864 Fax 201-392-6558</p>	
<p><b>JVC CORPORATION MIDWEST BRANCH</b> 2250 Lively Blvd. Elk Grove, IL 60007 312- 364-9300 1-800-323-0586</p>	<p><b>SHARP ELECTRONICS CORP. PRO</b> Sharp Plaza Mahwah, NJ 07430 201-529-8662 Fax: 201-512-2015</p>	

Section 12 • Reference Materials

**12/A**  
**Addresses**

---

12/A - MA

Manufacturer Addresses

---

12/A - MA - TV

TV Receivers and Monitors

---

# 12/A Addresses

12/A - MA

Manufacturer Addresses

12/A - MA - VP

Video Products

## 12/A - MA Manufacturer Addresses

## 12/A - MA - VP Video Products

<p><b>CAMCORDERS — BETA, SVHS, VHS, 8MM, HI-8</b></p> <p>AMPEX CORP. MARKETING SALES SERVICE 401 Broadway Redwood City, CA 94063-3199 415-367-3055 Fax: 415-367-2320</p> <p>BTS BROADCAST TELEVISION SYSTEMS 4827 N. Sepulveda Blvd. Sherman Oaks, CA 91403 818-972-8000 Fax: 818-986-1210</p> <p>CANON US BROADCAST EQUIPMENT DIV. 610 Palisade Ave. Englewood Cliffs, NJ 07632 201-816-2900</p> <p>IKEGAMI ELECTRONICS (USA) INC. 37 Brook Ave. Maywood NJ 07607 201-368-9171 Fax: 201-569-1626</p> <p>JVC PROFESSIONAL PRODUCTS, CO. 41 Slater Drive Elmwood Park, NJ 07407 201-794-3900 Fax: 201-523-2077</p>	<p>JVC CORPORATION EAST COAST I-80 at New Maple Ave. Pinebrook, NJ 07058 (201) 882-0900 800-247-3608</p> <p>JVC CORPORATION WEST COAST 1111 West Artesia Blvd. Compton, CA 90220 (213) 537-6020 800-421-6991</p> <p>JVC CORPORATION MIDWEST BRANCH 2250 Lively Blvd. Elk Grove, IL 60007 (312) 364-9300 800-323-0586</p> <p>JVC CORPORATION SOUTHWEST BRANCH 407 Garden Oaks Blvd. Houston, TX 77018 (713) 694-0666 800-231-6839</p> <p>PANASONIC COMMUNICATIONS &amp; SYSTEMS CO. Audio/Video Systems Group One Panasonic Way Secaucus, NJ 07094 201-348-7671 800-524-0864 Fax: 201-392-6558</p>	<p>RICOH CORP. CONSUMER/ PRODUCTS GROUP 180 Passaic Ave. Fairfield, NJ 07004 201-882-2000 800-225-1899 Fax: 201-808-3608</p> <p>SHARP ELECTRONICS CORP. Professional Products Div. Sharp Plaza Mahwah, NJ 07430 201-529-8662 Fax: 201-512-2015</p> <p><b>VIDEO RECORDERS — SVHS, VHS</b></p> <p>BURLE INDUSTRIES, INC. Security and Tube Div. 1000 New Holland Lancaster, PA 17601-5688 717-295-6123 800-326-3270 Fax: 717-295-6097</p> <p>DNF Industries 1032 N. Sweetzer Ave., Suite 212 West Hollywood, CA 90069 213-650-5256 Fax: 213-650-6639</p>
---	---	--

# 12/A

## Addresses

12/A - MA

Manufacturer Addresses

12/A - MA - VP

Video Products

DP Electronics  
152 Floyd Ave.  
Bloomfield, NJ 07003  
201-748-6334  
Fax: 201-743-3195

HITACHI DENSHI AMERICA, LTD.  
150 Crossways Park Drive  
Woodbury, NY 11797  
516-921-7200

JVC PROFESSIONAL PRODUCTS  
CORP.  
41 Slater Drive  
Elmwood Park, NJ 07407  
201-794-3900  
Fax: 201-523-2077

JVC CORPORATION  
EAST COAST  
I-80 at New Maple Ave.  
Pinebrook, NJ 07058  
(201) 882-0900  
800-247-3608

JVC CORPORATION  
WEST COAST  
1111 West Artesia Blvd.  
Compton, CA 90220  
(213) 537-6020  
800-421-6991

JVC CORPORATION  
MIDWEST BRANCH  
2250 Lively Blvd.  
Elk Grove, IL 60007  
(312) 364-9300  
800-323-0586

JVC CORPORATION  
SOUTHWEST BRANCH  
407 Garden Oaks Blvd.  
Houston, TX 77018  
(713) 694-0666  
800-231-6839

MITSUBISHI ELECTONICS  
AMERICA, PRO ELECTRONICS  
DIV.  
800 Cottontail Lane  
Somerset, NJ 08873-6759  
908-563-9889  
800-733-8439  
Fax: 908-563-0713

NEC TECHNOLOGIES INC.  
PROFESSIONAL SYSTEMS DIV.  
1255 Michael Drive  
Wood Dale, IL 60191-1094  
708-860-9500  
800-366-3632  
Fax: 708-860-5812

PANASONIC COMMUNICATIONS  
& SYSTEMS CO.  
One Panasonic Way  
Secaucus, NJ 07094  
201-348-7671  
800-524-0864  
Fax: 201-392-6558

SANYO FISHER CORP.  
INDUSTRIAL VIDEO DIV.  
1200 W. Artesia Blvd.  
Compton, CA 90220  
213-605-6527  
Fax: 213-605-6529

SHARP ELECTRONICS CORP.  
PROFESSIONAL PRODUCTS.  
Sharp Plaza  
Mahwah, NJ 07430  
201-529-8662  
Fax: 201-512-2015

**12/1 - A**  
**Abbreviations**

<b>A</b>			
<b>a</b>	anode	<b>a.v.c. / AVC</b>	automatic volume control
<b>A</b>	Ampere	<b>AWG</b>	American Wire Gauge
<b>ABC</b>	American Broadcasting Company	<b>B</b>	
<b>a.c. / AC</b>	Anti-clockwise	<b>b</b>	base
<b>ADC</b>	analog-to-digital converter	<b>BABT</b>	British Approvals Board for Telecommunications
<b>Ae.</b>	aerial	<b>BARITT</b>	barrier injected transit time diode
<b>a.f. / AF</b>	audio frequency	<b>bel</b>	ratio of two amounts of power
<b>AF</b>	audio frequency	<b>BBC</b>	British Broadcasting Corporation
<b>a.f.c. / AFC</b>	automatic frequency control	<b>BCD</b>	binary coded decimal
<b>a.g.c. / AGC</b>	automatic gain control	<b>BCS</b>	British Computer Society
<b>AISb</b>	aluminum antimonide	<b>BFO</b>	beat frequency oscillator
<b>a.l.c. / ALC</b>	automatic level control	<b>BHJT</b>	bipolar heterojunction transistor
<b>ALS</b>	advanced low-power Schottky	<b>BICMOS</b>	bipolar complementary metal oxide semiconductor
<b>ALSTTL</b>	advanced low-power Schottky transistor-transistor logic	<b>BJT</b>	bipolar junction transistor
<b>ALU</b>	arithmetic logic unit	<b>bps / BPS</b>	bits per second
<b>AM</b>	amplitude modulation	<b>BS</b>	British Standard
<b>ANSI</b>	American National Standards Institute	<b>B&amp;S</b>	Brown and Sharpe gauge. Same as AWG
<b>ARRL</b>	American Radio Relay League	<b>BSI</b>	British Standards Institute
<b>ASA</b>	American Standards Association	<b>BTEC</b>	Business and Technician Education Council
<b>ASCII</b>	American Standard Code for Information Interchange	<b>BX</b>	the moving portion of a relay, bell or buzzer
<b>ASIC</b>	application specific integrated circuit	<b>B-Y</b>	Blue minus luminance (Y) color TV signal
<b>ATE</b>	automatic test equipment		
<b>ATU</b>	aerial tuning unit		
<b>ATTD</b>	avalanche transit time device		
<b>Aux.</b>	auxiliary		

<b>C</b>		<b>CMOS</b>	complementary metal oxide semiconductor
<b>c</b>	cathode	<b>CMRR</b>	common-mode rejection ratio
<b>c</b>	collector	<b>COMFET</b>	conductivity modulated field effect transistor
<b>C</b>	capacitor	<b>c.p.s.</b>	cycles per second
<b>C</b>	Coulomb	<b>CPU</b>	central processing unit
<b>C</b>	degree Celsius	<b>Cr</b>	chromium
<b>CAD</b>	computer aided design	<b>CRO</b>	cathode ray oscilloscope
<b>CAM</b>	computer aided machine	<b>CrO2</b>	chromium dioxide
<b>cap / CAP</b>	capacitor	<b>CRT</b>	cathode ray tube
<b>CATV</b>	community antenna television	<b>CRTC</b>	cathode ray tube controller
<b>CB</b>	Citizens' Band	<b>c.s.a.</b>	cross sectional area
<b>CBIC</b>	complementary bipolar integrated circuit	<b>CSA</b>	Canadian Standards Association
<b>CBS</b>	Columbia Broadcasting System	<b>c.t.</b>	center tap
<b>CCD</b>	charge coupled device	<b>C/T</b>	current transformer
<b>CCIR</b>	Consultative Committee for International Radio	<b>CTD</b>	charge transfer device
<b>CCITT</b>	Consultative Committee for Telegraph and Telephone	<b>CTR</b>	current transfer ratio
<b>CCTV</b>	closed-circuit television	<b>CTS</b>	clear to send
<b>c.c.w.</b>	counter-clockwise	<b>CW / cw / c-w</b>	continuous wave
<b>cd</b>	candela	<b>CW</b>	counter-clockwise
<b>Cd</b>	cadmium	<b>D</b>	
<b>CD</b>	compact disc (player or disc)	<b>d</b>	drain
<b>CDI</b>	collector diffusion isolation	<b>D</b>	diode
<b>CdS</b>	cadmium sulphide	<b>D</b>	deka
<b>CdTe</b>	cadmium telluride	<b>D/A</b>	digital-to-analog converter
<b>CERDIP</b>	ceramic dual in-line package	<b>DAC</b>	digital audio tape
<b>chan.</b>	channel	<b>dB</b>	decibel
<b>CHINT</b>	charge injection transistor	<b>dBm</b>	decibel (relative to 1 mW)
<b>CIX</b>	Compulink Information Exchange	<b>DBS</b>	direct broadcast satellite
<b>CLK</b>	clock	<b>dBV</b>	decibel (relative to 1 V)
<b>cm</b>	centimeter	<b>d.c. / DC</b>	direct current

<b>DCE</b>	data circuit-terminating equipment	<b>EBU</b>	European Broadcasting Union
<b>dec.</b>	decimal	<b>e.c.c.</b>	earth continuity conductor
<b>deka</b>	meaning 10	<b>ECMA</b>	European Computer Manufacturers' Association
<b>DEMUX</b>	demultiplexer	<b>EEPROM</b>	electrically erasable programmable read-only memory
<b>DIL</b>	dual in-line	<b>EEROM</b>	electrically erasable read-only memory
<b>DIN</b>	German Industry Standard	<b>E<sup>2</sup>ROM</b>	electrically erasable read-only memory
<b>DIP</b>	dual in-line package	<b>ECL</b>	emitter coupled logic
<b>DMA</b>	direct memory access	<b>EHF</b>	extremely high frequency
<b>DMM</b>	digital multimeter	<b>EHT</b>	extra high tension
<b>DMOS</b>	double diffused metal oxide semiconductor	<b>EIA</b>	Electronic Industries Association
<b>DOS</b>	disk operating system	<b>EITB</b>	Engineering Industry Training Board
<b>DP</b>	data processing	<b>e.i.r.p.</b>	effective isotropically radiated power
<b>DPDT</b>	double-pole, double-throw	<b>ELED</b>	edge-emitting light emitting diode
<b>DPST</b>	double-pole, single-throw	<b>EM</b>	electromagnetic
<b>DRAM</b>	dynamic random access memory	<b>EMC</b>	electromagnetic compatibility
<b>DSB</b>	double sideband	<b>e.m.f.</b>	electromagnetic force
<b>DSP</b>	digital signal processing	<b>EMI</b>	electromagnetic interference
<b>DTE</b>	data terminal equipment	<b>EMP</b>	electromagnetic electromagnetic pulse
<b>DTI</b>	Department of Trade and Industry	<b>EPROM</b>	erasable-programmable read-only memory
<b>DTL</b>	diode-transistor logic	<b>EROM</b>	erasable read-only memory
<b>DTMF</b>	dual-tone multi-frequency	<b>ERP</b>	effective radiated power
<b>DUT</b>	device under test	<b>ESD</b>	electrostatic discharge
<b>DVM</b>	digital voltagemeter	<b>F</b>	
<b>DX</b>	long distance	<b>f</b>	frequency
<b>E</b>		<b>f / F</b>	Farad
<b>e / E</b>	emitter		
<b>E</b>	earth		
<b>EAROM</b>	electrically alterable read-only memory		
<b>EBCD</b>	extended binary coded decimal		

<b>FAX</b>	facsimile	<b>GHz</b>	gigahertz
<b>fc</b>	cut-off frequency	<b>Giga</b>	meaning one billion (10 <sup>9</sup> )
<b>FCC</b>	Federal Communications Commission	<b>gilbert</b>	unit of magnetomotive force
<b>FDC</b>	floppy disk controller	<b>gm</b>	mutual conductance of a tube
<b>FDM</b>	frequency division multiplex	<b>GMT</b>	Greenwich mean time
<b>Fe</b>	ferrous	<b>GND</b>	ground
<b>FeCr</b>	ferri-chrome	<b>GPIB</b>	general purpose interface bus
<b>FET</b>	field effect transistor	<b>GTO</b>	gate turn off
<b>FIFO</b>	first-in first-out	<b>G-Y</b>	green minus the luminance (Y) signal in TV color
<b>FL</b>	filter	<b>H</b>	
<b>FLL</b>	frequency-locked loop	<b>H</b>	Henry
<b>fm / FM</b>	frequency modulation	<b>HDTV</b>	high definition television
<b>FPGA</b>	field programmable gate array	<b>hex.</b>	hexadecimal
<b>FPLA</b>	field programmable logic array	<b>HEMT</b>	high electron mobility transistor
<b>FPRM</b>	field programmable read-only memory	<b>HF</b>	high frequency
<b>FRU</b>	field replaceable unit	<b>HMOS</b>	high-speed metal oxide semiconductor
<b>FSD</b>	full-scale defelection	<b>HPIB</b>	Hewlett-Packard interface bus
<b>FSK</b>	frequency-shift keying	<b>h.t.</b>	high tension
<b>FSM</b>	frequency shift modulation	<b>h.v.</b>	high voltage
<b>FSTV</b>	fast-scan television	<b>Hz</b>	Hertz
<b>ft</b>	transition frequency	<b>I</b>	
<b>G</b>		<b>I</b>	current
<b>g</b>	gate	<b>IA5</b>	International Alphabet No. 5
<b>G</b>	Giga (x 10 <sup>9</sup> )	<b>i.c. / IC</b>	integrated circuit
<b>GaAlAs</b>	gallium aluminum arsenide	<b>ICE</b>	in-circuit emulation
<b>GaAs</b>	galium arsenide	<b>IEC</b>	International Electrotechnical Commission
<b>GaInAsP</b>	gallium indium arsenide phosphide	<b>IEE</b>	Institution of Electrical Engineers
<b>GaP</b>	gallium phosphide	<b>IEEE</b>	Institution of Electrical and Electronic Engineers
<b>GDP</b>	graphic display processor		
<b>Ge</b>	germanium		



<b>IEEIE</b>	Institution of Electrical and Electronics Incorporated Engineers	<b>JUGFET</b>	junction gate field effect transistor
<b>IERE</b>	Institution of Electronic and Radio Engineers	<b>K</b>	
<b>IF</b>	intermediate frequency	<b>k</b>	cathode
<b>IGFET</b>	insulated gate field effect transistor	<b>k</b>	kilo (x 10 <sup>3</sup> )
<b>IGT</b>	insulated gate transistor	<b>K</b>	binary kilo (x1024)
<b>IHF</b>	Institute of High Fidelity	<b>°K</b>	degree Kelvin
<b>IKBS</b>	intelligent knowledge-based systems	<b>Kb</b>	kilobyte
<b>I<sup>2</sup>L</b>	integrated injection logic	<b>kc / KC</b>	kilocycle
<b>IMD</b>	intermodulation	<b>kg</b>	kilogram
<b>IMPATT</b>	impact ionization avalanche transit time diode	<b>KHz</b>	kilohertz
<b>In</b>	indium	<b>km</b>	kilometer
<b>In P</b>	indium phosphide	<b>k W</b>	kilo ohm
<b>In Sb</b>	indium antimonide	<b>kV</b>	kilovolt
<b>inv.</b>	inverter	<b>kW</b>	kilowatt
<b>I/O</b>	input/output	<b>L</b>	
<b>I/P</b>	input	<b>L</b>	inductor or coil
<b>I<sup>2</sup>R</b>	power (in watts) expressed in terms of current (I) and resistance (R)	<b>L</b>	left (channel)
<b>IR</b>	infrared	<b>LAN</b>	local area network
<b>ISL</b>	integrated Schottky logic	<b>LASER</b>	light amplification by stimulated emission of radiation
<b>ISO</b>	International Standards Organization	<b>LCC</b>	leadless chip carrier
<b>IT</b>	information technology	<b>LCD</b>	liquid crystal display
<b>ITeC</b>	Information Technology Center	<b>LDR</b>	light dependant resistor
<b>ITU</b>	International Telecommunications Union	<b>LED</b>	light emitting diode
<b>J</b>		<b>LF</b>	low frequency
<b>J</b>	Joule	<b>i.h.</b>	left-hand
<b>JAN</b>	joint Army/Naval	<b>LIFO</b>	last-in first-out
<b>JFET</b>	junction field effect transistor	<b>lm</b>	lumen
		<b>LOC MOS</b>	locally oxidized complementary metal oxide semiconductor
		<b>LPE</b>	liquid phase epitaxy

<b>l.s.</b>	loudspeaker	<b>mH</b>	millihenry
<b>LS</b>	low-power Schottky	<b>mho</b>	the opposite of resistance. measurement for conductance or admittance.
<b>LSA</b>	limited space-charge accumulation	<b>MHz</b>	megahertz
<b>LSB</b>	lower sideband	<b>mic.</b>	microphone
<b>LSB</b>	least-significant bit	<b>MINIDIP</b>	miniature dual-in-line package
<b>LSD</b>	least-significant digit	<b>mm</b>	millimeter
<b>LSI</b>	large scale integration	<b>MMIC</b>	monolithic microwave integrated circuit
<b>l.t.</b>	low tension	<b>M Ω</b>	megohm
<b>l.v.</b>	low voltage	<b>MODEM</b>	modulator/demodulator
<b>LVDT</b>	linear variable differential transducer	<b>MOS</b>	metal oxide silicon
<b>LVRT</b>	linear variable reluctance transducer	<b>MOSFET</b>	metal oxide silicon field effect transistor
<b>l.w.</b>	long wave	<b>MOST</b>	metal oxide semiconductor transistor
<b>lx</b>	lux	<b>MPU</b>	microprocessor unit
<b>M</b>		<b>MPX</b>	multiplex
<b>m</b>	meter	<b>MSB</b>	most-significant bit
<b>m</b>	milli (x 10 <sup>-3</sup> )	<b>MSD</b>	most-significant-digit
<b>M</b>	mega (x 10 <sup>6</sup> )	<b>MSI</b>	medium scale integration
<b>mA</b>	milliamp	<b>mt</b>	main terminal
<b>MAC</b>	multiplexed analogue components	<b>MTBF</b>	mean time between failure
<b>MAP</b>	Manufacturing Automation Protocol	<b>MTTF</b>	mean time to failure
<b>MBE</b>	molecular beam epitaxy	<b>MTTR</b>	mean time to repair
<b>m.c.</b>	moving coil	<b>MUX</b>	multiplexer
<b>MC</b>	megacycle	<b>mV</b>	millivolt
<b>MCW</b>	modulated continuous wave	<b>mW</b>	milliwatt
<b>MESFET</b>	metal semiconductor field effect transistor	<b>m.w.</b>	medium wave
<b>μF</b>	microfarad	<b>N</b>	
<b>MF</b>	medium frequency	<b>n</b>	nano (x 10 <sup>-9</sup> )
<b>MFM</b>	modified frequency modulation	<b>n / N</b>	negative
		<b>N</b>	Newton
		<b>NAB</b>	National Association of Broadcasters

<b>NBC</b>	National Broadcasting Company	<b>P</b>	
<b>NBS</b>	National Bureau of Standards	<b>p</b>	pico (x 10 <sup>-12</sup> )
<b>n.c. / NC</b>	not connected	<b>p / P</b>	positive
<b>nF</b>	nanofarad	<b>P</b>	power
<b>nH</b>	nanoHenry	<b>P</b>	plate of electron tube
<b>Ni</b>	nickel	<b>PA</b>	power amplifier
<b>NiCd</b>	nickel cadmium	<b>PAL</b>	phase alternate line
<b>NMOS</b>	N-channel metal oxide semiconductor	<b>PAL</b>	programmable array logic
<b>NOVRAM</b>	non-volatile random access memory	<b>PAM</b>	pulse amplitude modulation
<b>n.p.n. / NPN</b>	negative-positive-negative	<b>pb.</b>	playback
<b>NRZ</b>	non-return to zero	<b>PC</b>	personal computer
<b>n.t.c.</b>	negative temperature coefficient	<b>p.c.b. / PCB</b>	printed circuit board
<b>NTC</b>	negative temperature coefficient	<b>PCM</b>	pulse code modulation
<b>NTSC</b>	National Television Systems Committee	<b>p.d.</b>	potential difference
<b>nV</b>	nanovolt	<b>PEP</b>	peak envelope power
<b>nW</b>	nanowatt	<b>pF</b>	picofarad
<b>O</b>		<b>PF</b>	power factor
<b>Ω</b>	Ohm	<b>PIO</b>	parallel input/output
<b>o.c.</b>	open circuit	<b>PIN</b>	positive intrinsic negative
<b>o.c.</b>	open collector	<b>PIPO</b>	parallel input, parallel output
<b>OCR</b>	optical character recognition	<b>PISO</b>	parallel input, serial output
<b>OD</b>	outside diameter	<b>pk</b>	peak
<b>OEM</b>	original equipment manufacturer	<b>pk-pk / P-P</b>	peak-to-peak
<b>OIC</b>	optically coupled integrated circuit	<b>PL</b>	plug
<b>O/P</b>	output	<b>PLA</b>	programmable logic array
<b>opamp</b>	operation amplifier	<b>PLC</b>	programmable logic controller
<b>OSI</b>	open systems interconnection	<b>PLL</b>	phase-locked loop
		<b>PM</b>	pulse modulation
		<b>PML</b>	programmed macro logic
		<b>PMOS</b>	P-channel metal oxide semiconductor
		<b>PMR</b>	private mobile radio
		<b>p.n. / PN</b>	positive-negative

<b>p.n.p. / PNP</b>	positive-negative-positive	<b>R</b>	
<b>PPI</b>	programmable parallel interface	<b>R</b>	resistor
<b>ppm</b>	parts per million	<b>R</b>	right (channel)
<b>PPM</b>	pulse position modulation	<b>RACES</b>	Radio Amateur Civil Emergency Service
<b>PPM</b>	peak program meter	<b>rad</b>	radian
<b>pps</b>	pulses per second	<b>RAM</b>	random access memory
<b>prf</b>	pulse repetition frequency	<b>RB</b>	ripple blanket
<b>PROM</b>	programmable read-only memory	<b>RC</b>	resistance capacitance
<b>PSD</b>	phase sensitive detector	<b>rec.</b>	record
<b>PSE</b>	packet switching exchange	<b>RF</b>	radio frequency
<b>PSK</b>	phase-shift keying	<b>RFC</b>	radio frequency choke
<b>PSRAM</b>	pseudo-static random access memory	<b>RFI</b>	radio frequency interference
<b>PSS</b>	Packet Switch Stream	<b>RGB</b>	red, green, blue (primaries for light color spectrum)
<b>PSU</b>	power supply unit	<b>r.h.</b>	right-hand
<b>p.t.c. / PTC</b>	positive temperature coefficient	<b>RIAA</b>	Record Industry Association of America
<b>PTFE</b>	polytetrafluoroethylene	<b>RISC</b>	reduced instruction set code
<b>p.u. / P/U</b>	pick-up	<b>RMM</b>	read-mostly memory
<b>PUJT</b>	programmable unijunction transistor	<b>r.m.s. / RMS</b>	root mean square
<b>PUT</b>	programmable unijunction transistor	<b>ROM</b>	read-only memory
<b>PVC</b>	polyvinylchloride	<b>RTC</b>	real-time clock
<b>PWB</b>	printed wiring board	<b>RTL</b>	resistor-transistor logic
<b>PWM</b>	pulse width modulation	<b>RTS</b>	request to send
<b>Q</b>		<b>RTTY</b>	radio teletype
<b>Q</b>	quality factor	<b>RV</b>	variable resistor
<b>Q</b>	transistor	<b>RX</b>	receiver
<b>QAM</b>	quadrature amplitude modulation	<b>RZ</b>	return to zero
<b>QDBS</b>	quasi-direct broadcasting by satellite	<b>S</b>	
<b>QIL</b>	quad in-line	<b>s</b>	source
		<b>s</b>	second
		<b>S</b>	Siemen
		<b>S</b>	switch

<b>SBC</b>	single-board computer	<b>SSB</b>	single sideband
<b>s.c.</b>	short circuit	<b>SSI</b>	small scale integration
<b>Sch.</b>	Schmitt	<b>SSTV</b>	slow-scan television
<b>SCR</b>	silicon controlled rectifier	<b>str.</b>	strobe
<b>SCS</b>	silicon controlled switch	<b>s.w. / SW</b>	short wave
<b>Se</b>	selenium	<b>SWG</b>	stranded wire gauge
<b>SECAM</b>	Sequential Couleur a Memoire	<b>SWL</b>	short wave listener
<b>SHF</b>	super high frequency	<b>SWR</b>	standing wave ratio
<b>Si</b>	silicon	<b>sync</b>	synchronization
<b>SI</b>	System International	<b>T</b>	
<b>SIL</b>	single in-line	<b>t</b>	time
<b>SIO</b>	serial input / output	<b>T</b>	Tesla
<b>SIPO</b>	serial input / parallel output	<b>T</b>	transformer
<b>SISO</b>	serial input / serial output	<b>TDM</b>	time division multiplex
<b>SK</b>	socket	<b>TED</b>	transferred electron device
<b>SLED</b>	surface-emitting light emitting diode	<b>THD</b>	total harmonic distortion
<b>SLSI</b>	super large scale integration	<b>THz</b>	terahertz
<b>SMATV</b>	satellite master antenna television	<b>TID</b>	transient intermodulation distortion
<b>SMC</b>	surface mounted component	<b>TOP</b>	technical and office protocol
<b>SMD</b>	surface mounted device	<b>tot.</b>	total
<b>SME</b>	Society of Manufacturing Engineers	<b>TP</b>	test point
<b>SMT</b>	surface mounted technology	<b>TR</b>	transistor
<b>S/N</b>	signal-to-noise	<b>TRAPATT</b>	trapped plasma avalanche triggered diode
<b>SNA</b>	systems network architecture	<b>TRF</b>	tuned radio frequency
<b>SNA</b>	systems network architecture	<b>tri.</b>	tri-state
<b>SNR</b>	signal-to-noise ratio	<b>trig.</b>	trigger
<b>SOP</b>	standard operating procedure	<b>TTL</b>	transistor-transistor logic
<b>SOS</b>	silicon on sapphire	<b>TTY</b>	teletype
<b>SPL</b>	sound pressure level	<b>TV</b>	television
<b>SPDT</b>	single-pole, double-throw	<b>TVI</b>	television interference
<b>SPST</b>	single-pole, single-throw	<b>TVRO</b>	television receive-only
<b>sr</b>	steradian	<b>TX</b>	transmit / transmitter
<b>SRAM</b>	static random access memory		

<b>U</b>		<b>VHF</b>	very high frequency
$\mu$	micro	<b>VHS</b>	video home system
$\mu\text{A}$	microamp	<b>VLF</b>	very low frequency
<b>UART</b>	universal asynchronous receiver/transmitter	<b>VLSI</b>	very large scale integration
$\mu\text{F}$	microfarad	<b>VMOS</b>	V-channel metal oxide semiconductor
$\mu\text{H}$	microhenry	<b>VOM</b>	volt-ohm-meter
<b>UHF</b>	ultra high frequency	<b>VR</b>	variable resistor
<b>UJT</b>	unijunction transistor	<b>VRAM</b>	video random access memory
<b>ULA</b>	uncommitted logic array	<b>VSB</b>	vestigial sideband
<b>ULSI</b>	ultra large scale integration	<b>VSWR</b>	voltage standing wave ratio
$\mu\text{m}$	micrometer	<b>VTVM</b>	vacuum-tube voltmeter
<b>UMOS</b>	U-channel metal oxide semiconductor	<b>VTR</b>	video tape recorder
<b>UPS</b>	uninterruptible power supply	<b>VU</b>	volume unit
<b>USART</b>	universal synchronous/asynchronous receiver/transmitter	<b>W</b>	
<b>USB</b>	upper sideband	<b>WAN</b>	wide area network
$\mu\text{V}$	microvolt	<b>W</b>	Watt
<b>UV</b>	ultra-violet	<b>W</b>	work
$\mu\text{W}$	microwatt	<b>Wb</b>	Weber
<b>V</b>		<b>X</b>	
<b>V</b>	Volt	<b>X / Xtal.</b>	reactance
<b>VA</b>	volt-ampere	<b>X / Xtal.</b>	crystal
<b>valve</b>	British equivalent of a tube	<b>Xc</b>	capacitive reactance
<b>VAN</b>	value added network	<b>XI</b>	inductive reactance
<b>VC</b>	variable capacitor	<b>Y</b>	
<b>VCA</b>	voltage controlled amplifier	<b>Y</b>	crystal
<b>VCO</b>	voltage controlled oscillator	<b>Z</b>	
<b>VCR</b>	video cassette recorder	<b>Z</b>	impedance
<b>VDR</b>	voltage dependent resistor	<b>ZD</b>	zener diode
<b>VDU</b>	visual display unit		
<b>VFC</b>	voltage-to-frequency converter		
<b>VFO</b>	variable frequency oscillator		

## 12/I - ERM

### Electronics Repair Manual Index

#### Numerical Index

3.58 MHz peaking adjustment	6/TTV-VCS-Mag T985/T986 Pages 8-10
3-beam laser optical pickup system	7/CD-F-CDPD Page 3
4.5 MHz trap adjustment	5/VCR-VCS-HiVT-34A Page 24
8 to 14 modulation	7/CD-F-CDD Page 5
80286 microprocessor	9/PC-VCS-286 Pages 1-3
	9/PC-C Page 4
80386 microprocessor	9/PC-C Page 5
80486 microprocessor	9/PC-C Page 5
8086 microprocessor	9/PC-C Page 4
8088 microprocessor	9/PC-C Page 4

#### A

A/D converter	7/CD-F-CDD Page 9
Absorption markers	6/TTV-TE-TV/V Page 12
AC	
adaptor charger	5/Cam-TR-EA-F Page 1
current gain	3/2-C-AC-T Page 3
head adjustment	5/VCR-VCS-HiVT-34A Page 15
Active Components	3/2-C-AC-A Page 1
Address bus	9/PC-AM Page 2
AFC	5/VCR-TR-VP-FPC Page 1
AFS adjustment	5/VCR-VCS-HiVT-34A Page 24
AFT	
circuit diagram	6/TTV-VCS-Mag T985/T986 Page 15
control module	6/TTV-VCS-Mag T985/T986 Page 14
waveform	6/TTV-VCS-Mag T985/T986 Page 9
AGC	
circuit	6/TTV-TR-T Page 1
sync module circuits	6/TTV-VCS-Mag T985/T986 Page 12
Air conditioner	
basic parts	10/TR-A/C•R-A Page 3
electrical problems	10/TR-A/C•R-EP Page 1
general overview	10/TR-A/C•R-A Page 1
heat pumps	10/TR-A/C•R-A Page 5
mechanical problems	10/TR-A/C•R-MP Page 1
refrigeration basics	10/TR-A/C•R-A Page 1
schematic symbols	10/TR-A/C•R-EP Pages 2-5
troubleshooting table	10/TR-A/C•R-MP Pages 2-4
Airway	2/3 Page 5
Aliasing	7/CD-F-CDPD Page 5
Alignment tools	5/VCR-TE Page 2
Alternating Current	3/2-PVC Page 2
AM	
antenna system	7/R-F-A Page 1

bandwidth	7/R-F-T-AMT Page 1
frequency conversion	7/R-F-T-AMT Page 2
IF amplifier	7/R-F-T-AMT Page 2
oscillator	7/R-F-T-AMT Page 2
receiver tracking test	7/R-TR-R Page 3
wave	7/R-F-T-AMT Page 1
Amplifier	
MIDI	7/A-A Pages 1-2
preamplifiers	7/A-TR-P Page 1
solid state amplifiers	7/A-TR-SSA Page 1
tube amplifiers	7/A-TR-TA Page 1
Amplifier stages	6/TTV-TR-IFA Page 1
Amplitude modulation	7/R-F-M Page 1
Analog meter	4/3-DMM Page 2
AND Gates	3/2-C-AC-L Page 3
Antenna	
amplifier	7/R-F-A Page 2
cable	7/R-F-A Page 2
function	7/R-F-A Page 2
problems	7/R-TR-Ch Page 1
testing/alignment	7/R-F-A Page 1
APC	5/VCR-TR-VP-FPC Page 1
Applied squarewave waveforms	4/3-O Page 8
Astable pulse generator	3/2-C-AC-Ti Page 3
Audio	
control head adjustment	5/VCR-VCS-HiVT-34A Page 14
control head	5/VCR-VCS-HiVT-34A Page 42
generator hookup	4/3-SS Page 15
generator	4/3-SS Page 14
heads	5/VCR-TR-AP-R Page 1
output level adjustment	5/VCR-VCS-HiVT-34A Page 27
playback circuit	5/VCR-TR-AP-R Page 3
record circuit	5/VCR-TR-AP-R Page 3
section repair	6/TTV-TR-AS Page 5
select circuit	5/VCR-TR-AP-M Page 2
selections	5/VCR-TR-AP-M Page 1
track	5/VCR-TR-AP-R Page 1
Automatic	
fine tuning	6/TTV-VCS-Mag T985/T986 Page 7
frequency control	7/R-F-T-AMT Page 5
gain control	7/R-F-T-AMT Page 5
gain control tests	7/R-TR-R Page 2
pulse control circuit	5/VCR-TR-VP-FPC Page 2
test equipment	4/2 Page 12
Automobile	
battery ratings	8/TR-PS-BS Page 2
battery basic functions	8/TR-PS-BS Page 1
electrical systems diagnostic	8/TR-PS-BS Page 1
noises	8/TR-R Page 2
radios introduction	8/TR-R Page 1
sealed battery	8/TR-PS-BS Page 1
Autoranging DMM	4/3-DMM Page 3
<b>B</b>	
B+ adjustment	6/TTV-VCS-Mag T985/T986 Page 13



- |                             |                                    |
|-----------------------------|------------------------------------|
| Back tension                | 5/VCR-TR-MA-TA Page 2              |
| Backfocus adjustment        | 5/Cam-TR-EA-F Page 1               |
| Bandwidth                   | 3/2-C-AC-OpAmp Page 3              |
| Bandwidth oscilloscope      | 4/3-O Page 3                       |
| Baseline curvature          | 6/TTV-TE-TV/V Page 7               |
| Basic circuits              | 3/2-O Page 3                       |
| Batteries                   | 3/PVC Page 3                       |
| Battery                     |                                    |
| charging procedure          | 8/TR-PS-BS Page 5                  |
| charging time required      | 8/TR-PS-BS Page 4                  |
| lamp                        | 8/TR-PS-CS Page 4                  |
| recharging procedures       | 8/TR-PS-BS Page 3                  |
| safety procedures           | 8/TR-PS-BS Page 4                  |
| Bench lamp                  | 4/1 Page 13                        |
| Beta                        | 5/Cam-A Page 1                     |
| Bipolar transistors         | 3/2-C-AC-T Page 1                  |
| Bistables                   | 3/2-C-AC-L Page 7                  |
| Black and white picture     | 6/TTV-TR-VS Page 4                 |
| Blocking oscillator circuit | 4/3-SS Page 6                      |
| Blower motor noise          | 8/TR-R Page 1                      |
| Box-type telephone network  | 11/Tel-TR-SP Page 6                |
| Brake                       |                                    |
| slider assembly             | 5/VCR-VCS-HiVT-34A Page 38         |
| switch pop                  | 8/TR-R Page 2                      |
| torque                      | 5/VCR-TR-MA-TC Page 1              |
| Bridge rectifier            | 3/2-C-AC-D Page 3                  |
| Brightness                  | 6/TTV-A Page 1                     |
| Buffers                     | 3/2-C-AC-L Page 2                  |
| Bulb check                  | 8/TR-ECM Page 4                    |
| Bunn Pour-Omatic            | 10/TR-HE-CM Page 3                 |
| Burst frequency adjustment  | 5/Cam-TR-EA-C Page 4               |
| Bus                         |                                    |
| compatible devices          | 3/2-C-AC-L Page 9                  |
| systems                     | 9/PC-AM Page 2                     |
| <br>                        |                                    |
| <b>C</b>                    |                                    |
| <br>                        |                                    |
| Camcorder                   |                                    |
| AGC                         | 5/Cam-TR-EA-BC Page 1              |
| AIC level waveforms         | 5/Cam-TR-EA-BC Page 1              |
| alignment setup             | 5/Cam-TE Page 2                    |
| auto white balance          | 5/Cam-F Page 2                     |
| autofocus                   | 5/Cam-F Page 1                     |
| autofocus control circuit   | 5/Cam-TR-VP-CC Page 1              |
| automatic iris              | 5/Cam-F Page 2                     |
| black level                 | 5/Cam-TR-EA-BC Page 2              |
| block diagram               | 5/Cam-A Page 2                     |
| case study                  | 5/Cam-VCS-Sha-VL-L285U Pages 16-27 |
| cassette switch             | 5/Cam-TR-VP-SC Page 1              |
| dark shading                | 5/Cam-TR-EA-BC Page 2              |
| electronic viewfinder       | 5/Cam-F Page 2                     |
| iris level adjustment       | 5/Cam-TR-EA-BC Page 1              |
| lens assembly               | 5/Cam-TR-VP-CC Page 1              |
| lens                        | 5/Cam-F Page 2                     |

light box	5/Cam-TE Page 2
light source	5/Cam-TE Page 1
maintenance	5/Cam-M Page 1
microphone/earphone	5/Cam-F Page 3
monitor	5/Cam-TE Page 1
picture creation	5/Cam-TR-VP-R Page 1
power supplies	5/Cam-F Page 3
power distribution	5/Cam-TR-VM Page 1
record tab	5/Cam-TR-VP-SC Page 1
reel sensors	5/Cam-TR-VP-SC Page 1
standby/operate switch	5/Cam-TR-VM Page 2
test/alignment charts	5/Cam-TE Page 2
tripod	5/Cam-TE Page 1
trouble sensors	5/Cam-TR-VP-R Page 1
tubes/chips	5/Cam-A Page 2
TV hookup	5/Cam-F Page 3
voltage measurements	5/Cam-TR-VM Page 1
Capacitance checkers	4/2 Page 3
Capacitor	
characteristics	3/2-C-PC-C Page 3
color coding	3/2-C-PC-C Page 4
frequency	3/2-C-PC-C Page 2
replacement	3/2-C-PC-C Pages 1-2
Capstan	4/1 Page 17
digital speed	5/VCR-TR-CSP Page 5
motor	5/VCR-VCS-HiVT-34A Page 35
speed adjustment	5/VCR-VCS-HiVT-34A Page 20
Carrier filter waveform	5/VCR-VCS-HiVT-34A Page 25
Cassette loading mechanism	5/VCR-VCS-HiVT-34A Page 28
CD	
bits percentage	7/CD-F-CDD Page 4
care	7/CD-M Page 1
connections/cables	7/CD-TR-DD Page 1
connectors	7/CD-F-CDPD Page 2
cross section	7/CD-F-CDD Page 1
design	6/TTV-VCS-Mag T985/T986 Page 1
differences	7/CD-F-CDPD Page 2
display panel	7/CD-F-CDPD Page 1
dust	7/CD-M Page 2
eye pattern	7/CD-F-CDD Page 4
inside cleaning	7/CD-M Page 4
loaded improperly	7/CD-TR-DM Page 1
loading mechanisms	7/CD-TR-DD Page 1
motor control circuit	7/CD-TR-DM Page 3
outside cleaning	7/CD-M Page 4
physical dimensions	7/CD-F-CDD Page 2
pits and lands	7/CD-F-CDD Page 2
scratches	7/CD-M Page 1
service equipment	7/CD-TR-DD Page 1
test disc	7/CD-TR-DD Page 1-2
Central LSI controller	5/VCR-TR-CSP Page 1
Ceramic capacitors	3/2-C-PC-C Page 4
CH1/CH2 Phase adjustment	5/VCR-VCS-HiVT-34A Page 22
Channel allocation	6/TTV-TR-T Page 1
Channel allocation frequency	6/TTV-TR-T Page 2

Charging systems	8/TR-PS-CS Page 1
Chopped-mode	4/3-O Page 6
Chroma	
carrier level	5/Cam-TR-EA-BC Page 2
circuit during record	5/VCR-TR-VP-C Page 1
demodulation	6/TTV-VCS-Mag T985/T986 Page 11
processing	5/Cam-TR-VP-SPC Page 2
set-up	5/Cam-TR-EA-C Page 1
Chromaticity	6/TTV-TR-VS Page 1
Chrominance	
section	6/TTV-TR-VS Page 5
signal	6/TTV-TR-VS Page 1
Circuit	
arrangements	3/2-C-AC-L Page 6
quick checking	8/TR-PS-CS Page 4
Circuit tester for automobile	8/TR-PS-CS Page 1
Circuit test	
aligning	8/TR-PS-CS Page 1
checklist	8/TR-PS-CS Page 1
signal tracing	8/TR-PS-CS Page 1
Circulation	2/3 Page 5
Cleaning	
fluid	7/CD-M Page 2
machines	7/CD-M Page 4
Clearing codes	8/TR-ECM Page 5
Closed-loop voltage gain	3/2-C-AC-OpAmp Page 1
Clutch plate assembly	5/VCR-VCS-HiVT-34A Page 37
CMOS	3/2-C-AC-L Page 2
Color picture signal	6/TTV-TR-VS Page 4
Color killer	
adjustment	6/TTV-VCS-Mag T985/T986 Page 10
circuit	5/VCR-TR-VP-C Page 2
Color	
picture tube tester	6/TTV-TE-TV/V Page 10
saturation	6/TTV-A Page 1
sync section	6/TTV-TR-VS Page 5
test jig	6/TTV-TE-TV/V Page 10
Color picture	
tube components	6/TTV-TR-CPT Page 1
tube conditions	6/TTV-TR-CPT Page 1
Colpitts oscillator circuit	4/3-SS Page 5
Common-mode	3/2-C-AC-OpAmp Page 3
Compound darlington transistors	3/2-C-AC-T Page 4
Compressed air	7/CD-M Page 2
Computer architecture diagram	9/PC-AM Page 1
Computer, 286	9/PC-VCS-286 Pages 1-10
Computerized testing device	4/2 Page 13
Conductors/Insulators	3/2-O Page 2
Confirming white balance	5/Cam-TR-EA-BC Page 6
Contrast/background adjustments	11/C-TR Page 8
Contrast	6/TTV-A Page 1
Control	
bus	9/PC-AM Page 2
inputs	3/2-C-AC-L Page 5
Controller	7/R-TR-DTR Page 3
Controls	

overview	10/TR-C Page 1
testing	10/TR-C Page 1
Conversion factors	3/2-QUS Page 3
Coolant temperature sensor 15	8/TR-ECM-CL Page 2
Coolant temperature sensor 14	8/TR-ECM-CL Page 2
Copier	
basics	11/C-A Page 2
drum	11/C-A Page 2
icons	11/C-TR Page 6
paper	11/C-A Page 3
pinch rollers	11/C-TR Page 3
problems	11/C-TR Page 5
start-up	11/C-TR Page 4
toner	11/C-A Page 3
Coprocessor ICs	9/PC-C Page 6
Cordless phone	
keypad	11/Tel-TR-CP-D Page 16
pilot tone	11/Tel-TR-CP-D Page 12
power circuits	11/Tel-TR-CP-D Page 4
CPU	9/PC-AM Page 1
	9/PC-C Page 4
Crimping tools	4/1 Page 6
Crosstalk canceller	5/VCR-TR-AP-R Page 4
CRP	2/3 Page 4
Cruise control	
adjustments	8/TR-ECM-CC Page 3
adjustments	8/A Page 4
electro-motor	8/A Page 5-6
pop	8/TR-R Page 1
switch	8/A Page 1
throttle cable	8/TR-ECM-CC Page 4
Cylinder	
head parts	5/VCR-VCS-HiVT-34A Page 32
lock detection	5/Cam-TR-VP-SC Page 2
motor	5/VCR-VCS-HiVT-34A Page 30
speed adjustment	5/VCR-VCS-HiVT-34A Page 19

## D

D/A converters	7/CD-F-CDPD Page 6
D-Type bistable	3/2-C-AC-L Page 8
Data bus	9/PC-AM Page 2
DC current gain	3/2-C-AC-T Page 3
Defective camcorder batteries	5/Cam-TR-EA-F Page 3
Deflection coil	5/Cam-TR-VP-CC Page 5
Desoldering	
braid	3/4-D Page 1
bulb	4/1 Page 15
wick	4/1 Page 15
Detail	6/TTV-A Page 2
Developers	11/C-A Page 4
Dew sensor	5/Cam-TR-VP-SC Page 2
Diagnostic mode	8/TR-ECM Page 5
Dial tracking problems	7/R-TR-Ch Page 2

Diesel engine noise	8/TR-R Page 2
Digital	
keyboard	11/C-A Page 2
logic probe	4/3-LP Page 1
multimeter features	4/3-DMM Page 3
Digitally tuned	
radio	7/R-TR-DTR Page 1
input keypad	7/R-TR-DTR Page 2
output	7/R-TR-DTR Page 2
power signals	7/R-TR-DTR Page 2
power supply	7/R-TR-DTR Page 2
synthesizer	7/R-TR-DTR Page 2
voltage	7/R-TR-DTR Page 2
Diode	
casings	3/2-C-AC-D Page 5
coding	3/2-C-AC-D Page 4
tests	4/3-DMM Page 7
Diodes	3/2-C-AC-D Page 1
Disc motor	7/CD-TR-DM Page 1
Discriminators	6/TTV-TR-AS Page 4
Disk	
controllers	9/PC-C Page 10
motor adjustment	7/CD-TR-DM Page 1
tray cleaning	7/CD-M Page 6
Display	7/R-TR-DTR Page 3
Distortion curve	4/3-SS Page 16
DMM	
current tests	4/3-DMM Page 4
for automobile	8/TR-PS-CS Page 1
voltage tests	4/3-DMM Page 4
DOC circuit	5/VCR-TR-VP Page 1
Dolby	5/VCR-TR-AP-R Page 2
Drum head	5/VCR-A-VHS Page 2
Dual trace oscilloscope	5/VCR-TE Page 1
Dynamic focus	
preset	5/Cam-TR-EA-F Page 3
release	5/Cam-TR-EA-F Page 1

## E

ECM	
intermittent	8/TR-ECM Page 7
replacement	8/TR-ECM Page 6
Electrical	
circuit adjustments	5/VCR-VCS-HiVT-34A Page 18
shock	2/3 Page 2
Electro-motor cruise control	8/TR-ECM-CC Page 5
Electrolyte levels	8/TR-PS-BS Page 2
Electronic	
control panels	10/TR-C Page 1
control module	8/TR-ECM Page 1
doorbell	10/TR-T Page 1
spark timing circuit 42	8/TR-ECM-CL Page 5
tuners	6/TTV-TR-T Page 5

viewfinder circuits	5/Cam-TR-VP-CC Page 4
Encapsulation	3/2-C-AC-IC Page 3
End-cutter	4/1 Page 2
EPROM	9/PC-AM Page 2
Exclusive OR gates	3/2-C-AC-L Page 4
Expansion slots	9/PC-C Page 4
<b>F</b>	
Fan-in/fan-out	3/2-C-AC-L Page 10
Farads	3/2-C-PC-C Page 1
Fax circuit board	11/F-A Page 3
Fax machine	
elements	11/F-A Page 1
Fax printer section	11/F-A Page 2
Fax transmission	11/F-A Page 1
FET transistors	3/2-C-AC-T Page 5
FF/REW idler arm assembly	5/VCR-VCS-HiVT-34A Page 37
FG PC board assembly	5/VCR-VCS-HiVT-34A Page 35
Field	
service mode	8/TR-ECM Page 5
strength meter	7/R-TR-A Page 1
Filtering	7/CD-F-CDPD Page 6
Fire safety	2/3 Page 3
First aid	2/3 Page 4
Floppy	
diskettes	9/PC-C Page 2
drives	9/PC-C Page 9
Flywheel	5/VCR-VCS-HiVT-34A Page 35
FM	
antenna system	7/R-F-A Page 1
demodulator test	7/R-TR-R Page 4
detector	7/R-F-T-FMT Page 3
filter and IF section	7/R-F-T-FMT Page 2
mixer	7/R-F-T-FMT Page 2
oscillator circuit	7/R-F-T-FMT Page 3
receiver tuner section	7/R-F-T-FMT Page 1
tuner functions	7/R-F-T-FMT Page 1
tuner oscillator	7/R-F-T-FMT Page 2
Focus	
circuit	7/CD-TR-L Page 3
preset adjustment	5/Cam-TR-EA-F Page 3
Forward	
biased diode	3/2-C-AC-D Page 1
current	3/2-C-AC-D Page 2
voltage drop	3/2-C-AC-D Page 2
Frame storage	7/CD-F-CDD Page 8
Frequency counter	5/VCR-TE Page 1
Frequency	
counter block diagram	4/3-F Page 2
generator	5/VCR-TR-CSP Page 2
measurement	4/3-F Page 4
modulation	7/R-F-M Page 1
Full erase head	5/VCR-VCS-HiVT-34A Page 41

Function generator	4/3-SS Page 12
Fuzzy	
logic	10/TR-C Page 4
vacuum cleaners	10/TR-C Page 4
<b>G</b>	
Gamma	6/TTV-A Page 1
General Supplies	4/1 Page 16
Generator	
noise	8/TR-PS-CS Page 1
testing	8/TR-PS-CS Page 2
trouble indication	8/TR-PS-CS Page 3
visual inspection	8/TR-PS-CS Page 3
wiring diagram	8/TR-PS-CS Page 3
Germanium diode	3/2-C-AC-D Page 3
GM terminal block	8/TR-ECM Page 3
Gray scale adjustment	6/TTV-VCS-Mag T985/T986 Page 10
Gripping screwdriver	4/1 Page 10
Grounded circuit	11/Tel-TR-TL Page 3
Guide	
pole	5/VCR-VCS-HiVT-34A Page 41
post height adjustment	5/VCR-VCS-HiVT-34A Page 13
roller head adjustment	5/VCR-VCS-HiVT-34A Page 15-17
<b>H</b>	
Hall gain balance	7/CD-TR-DM Page 1
Handset	11/Tel-TR-SP Page 1
Hard disk	
alignment	9/PC-TR-HD Page 1
cable	9/PC-TR-HD Page 1
common problems	9/PC-TR-HD Page 1
Hard drives	9/PC-C Page 10
Hard disk installation	9/PC-TR-HD Page 1
Hartley oscillator circuit	4/3-SS Page 4
Helping hand	4/1 Page 4
Hemostats	4/1 Page 4
Heterodyne	
counter	4/3-F Page 8
principle	4/3-SS Page 7
Hi-Fi audio	5/VCR-TR-AP-R Page 2
High	
frequency counting	4/3-F Page 7
frequency decoupling	3/2-C-AC-VR Page 5
voltage adjustment	6/TTV-VCS-Mag T985/T986 Page 13
Hitachi VT-34A	
main chassis	5/VCR-VCS-HiVT-34A Page 6
overview	5/VCR-VCS-HiVT-34A Page 1
removal of parts	5/VCR-VCS-HiVT-34A Pages 2-3
specifications	5/VCR-VCS-HiVT-34A Page 2
Horizontal	
deflection	6/TTV-TR-DC Page 3

module circuit	6/TTV-VCS-Mag T985/T986 Page 15
osc. adjustment	6/TTV-VCS-Mag T985/T986 Page 13
Horn noise in radio	8/TR-R Page 2
HQ Circuitry	5/Cam-F Page 3
Hue	6/TTV-A Page 2
Hydrometer	8/TR-PS-BS Page 1

**I**

I and O signals	6/TTV-TR-VS Page 6
I/O devices	9/PC-AM Page 2
IC	
coding	3/2-C-AC-IC Page 3
installer	4/1 Page 11
puller	4/1 Page 12
removal	3/3-D Page 2
tools	4/1 Page 11
tuner circuit	6/TTV-TR-T Page 8
tuner block diagram	6/TTV-TR-T Page 6
IC301	7/CD-TR-DD Page 2
IF	
amplifier check	7/R-TR-R Page 5
amplifier oscillation tests	7/R-TR-R Page 1
frequency	6/TTV-TR-T Page 3
IGFET transistors	3/2-C-AC-T Page 5
Inductor	
functions	3/2-C-PC-I Page 1
replacement	3/2-C-PC-I Page 2
symbols	3/2-C-PC-I Page 2
Input	
offset voltage	3/2-C-AC-OpAmp Page 2
resistance	3/2-C-AC-OpAmp Page 2
Inspection mirror	4/1 Page 12
Integrated circuits	3/2-C-AC-IC Page 1
Intercarrier sound system diagram	6/TTV-TR-AS Page 2
Interchangeability checks	5/VCR-TR-MA-HA Page 1
Intermittent reception	6/TTV-TR-T Page 9
Internal modem	11/F-A Page 2
Interrupt connections to keyboard	10/TR-C Page 3
Inverters	3/2-C-AC-L Page 2
IR light	5/Cam-TR-VP-CC Page 1

**J**

J-K bistable	3/2-C-AC-L Page 8
--------------	-------------------

**K**

Keyboard	
cable	9/PC-TR-K Page 1



connector	9/PC-C Page 3
lubrication	9/PC-TR-K Page 2
power	9/PC-TR-K Page 1
removing keys	9/PC-TR-K Page 2
switching mechanisms	9/PC-TR-K Page 2
Knife	4/1 Page 5
<b>L</b>	
L-C circuits	4/3-SS Page 4
Laser	
diode	7/CD-TR-L Page 1
circuits	7/CD-TR-L Page 3
Laser lens	
assembly	7/CD-TR-L Page 3
cleaning	7/CD-M Page 5
Laser Printer	
control circuits	9/PR-TR-LP Page 4
diodes	9/PR-TR-LP Page 3
drums	9/PR-TR-LP Page 5
general operation	9/PR-TR-LP Page 1
paper jams	9/PR-TR-LP Page 5
smearing	9/PR-TR-LP Page 5
test page	9/PR-TR-LP Page 6
toner	9/PR-TR-LP Page 5
Laserbeam	7/CD-F-CDPD Page 3
Leading/lagging voltages	4/3-O Page 16
LED probe	4/3-LP Page 2
Light emitting diodes	3/2-C-LED Page 1
Line	
probe	11/Tel-TE Page 1
Lissajous figures	4/3-0 Page 9
Load testing	8/TR-PS-BS Page 2
Loading	
gear assembly	5/VCR-VCS-HiVT-34A Page 38
mechanism assembly	5/VCR-VCS-HiVT-34A Page 29
motor board assembly	5/VCR-VCS-HiVT-34A Page 35
Local oscillator checking	7/R-TR-R Page 1
Logic	
ICs	3/2-C-AC-L Page 1
levels	3/2-C-AC-L Page 8
probe block diagram	4/3-LP Page 2
probe operating principles	4/3-LP Page 2
pulsar	4/3-LP Page 2
Logical functions	3/2-C-AC-L Page 2
Loop filter	7/R-TR-DTR Page 4
Low frequency	4/3-SS Page 17
Low/high	
channels with problems	6/TTV-TR-T Page 9
chroma levels	6/TTV-TE-TV/V Page 5
Low frequency	
tilting	4/3-SS Page 18
measurement	4/3-F Page 7
Lower cylinder	5/VCR-VCS-HiVT-34A Page 33

Luminance  
  processing  
  signal  
5/Cam-TR-VP-SPC Page 1  
6/TTV-TR-VS Page 1

**M**

Magnavox TS checklist  
Magnavox disassembly  
Magnetic flux  
Magnifying glass  
Map sensor code 34  
Maximum output voltage swing  
MC33034  
  brushless motor control  
MC33035  
  motor control IC  
MC34012  
  ringer replacement  
Mechanical electronic tuners  
Mechanism state switch  
Melody doorbell  
Memory  
Merging bits  
Miniature camcorder  
Minimum voltage list  
Mirror  
Miscellaneous problems  
Misfed paper  
Mixer stage circuit  
Mode sensor switch  
Modulation  
Modulation problems  
Monitors  
Monochrome clusters  
Monostables  
Monstable pulse generator  
Motherboard  
Motor  
  block assembly  
  marking alignments  
Motorola  
Mouth-to-mouth  
Multidrawer cabinets  
Multiloop frequency synthesizer  
Multiple DMM ranges  
Multivibrators  
Multiwire cutter  
6/TTV-VCS-Mag T985/T986 Page 2-5  
6/TTV-VCS-Mag T985/T986 Page 1  
5/VCR-A-VHS Page 1  
4/1 Page 13  
8/TR-ECM-CL Page 4  
3/2-C-AC-OpAmp Page 3  
10/TR-ECM Page 1  
10/TR-ECM Page 2  
11/Tel-TR-SP Page 4  
6/TTV-TR-T Page 4  
5/VCR-VCS-HiVT-34A Page 6  
10/TR-T Page 3  
9/PC-C Page 6  
7/CD-F-CDD Page 7  
5/Cam-A Page 2  
8/TR-PS-BS Page 3  
4/1 Page 13  
7/R-TR-Ch Page 3  
11/C-TR Page 1  
7/R-F-T-FMT Page 4  
5/Cam-TR-VP-SC Page 1  
6/TTV-TR-VS Page 3  
7/R-TR-Ch Page 2  
9/PC-C Page 7  
6/TTV-TE-TV/V Page 5  
3/2-C-AC-L Page 4  
3/2-C-AC-Ti Page 3  
9/PC-C Page 4  
5/VCR-VCS-HiVT-34A Page 28  
5/VCR-VCS-HiVT-34A Page 31  
3/2-C-AC-D Page 6  
2/3 Page 7  
4/1 Page 17  
4/3-SS Page 11  
4/3-DMM Page 4  
4/3-SS Page 6  
4/1 Page 2

**N**

NAND Gate  
Needlenose pliers  
3/2-C-AC-L Page 4  
4/1 Page 3

Networks	11/Tel-TR-SP Page 3
Noise	
margins	3/2-C-AC-L Page 8
power spectrum	4/3-SS Page 12
problems	7/R-TR-Ch Page 1
NOR Gate	3/2-C-AC-L Page 4
NPN transistors	3/2-C-AC-T Page 2
NTSC color bar	5/VCR-TE Page 1
Nut drivers	4/1 Page 8
<b>O</b>	
Oblique cutter	4/1 Page 2
Offset-null facility	3/2-C-AC-Op Amp Page 4
Ohm's	
law formula	3/2-O Page 1
test	4/3-DMM Page 5
Open circuit	11/Tel-TR-TL Page 2
Open circuit voltage test	8/TR-PS-BS Page 3
Open-loop voltage gain	3/2-C-AC-Op Amp Page 1
Operational amplifiers	3/2-C-AC-Op Amp Page 1
OR Gates	3/2-C-AC-L Page 3
Oscillator problems	8/TR-PS-CS Page 1
Oscilloscope	
accuracy	4/3-O Page 7
alternate mode	4/3-O Page 5
probe	4/3-O Page 7
Output	
resistance	3/2-C-AC-Op Amp Page 2
waveform characteristics	3/2-C-AC-Ti Page 4
Overdischarge detection circuit	5/Cam-TR-EA-F Page 5
Oxygen sensor circuit	8/TR-ECM-CL Page 1

**P**

Paper	
input	11/C-A Page 2
path	11/C-TR Page 2
Parameters of LED	3/2-C-LED Page 2
Parity and error correction	7/CD-F-CDD Page 8
Passive components	3/2-C-PC-A Page 1
Pattern generators	6/TTV-TE-TV/V Page 9
PC	
based fax	11/F-A Page 2
board removals	5/VCR-VCS-HiVT-34A Page 5
board cleaning	7/CD-M Page 6
disk drive bays	9/PC-C Page 2
key lock	9/PC-C Page 2
monitor and cards	9/PC-TR-MC Page 1
power supplies	9/PC-C Page 11
power switch	9/PC-C Page 1
power connections/supply	9/PC-C Page 3

reset switch	9/PC-C Page 1
speed switch	9/PC-C Page 1
Period measurement waveform	4/3-F Page 5
Phase	
inversion on VHS machine	5/VCR-TR-VP-PI Page 1
FM stereo demodulation	7/R-TR-R Page 7
lock-loop detector	6/TTV-TR-AS Page 5
Phone	
automatic test equipment	11/Tel-TR-TL Page 2
circuits crossed	11/Tel-TR-TL Page 5
cords	11/Tel-TR-SP Page 1
corrosion	11/Tel-TR-TL Page 2
cracking/static	11/Tel-TR-TL Page 1
disconnects	11/Tel-TR-TL Page 3
dust/debris	11/Tel-TR-TL Page 6
intermittent problem	11/Tel-TR-TL Page 1
line testing	11/Tel-TR-TL Page 1
line noise	11/Tel-TR-TL Page 4
wire damage	11/Tel-TR-TL Page 2
Pick-up motor offset	7/CD-TR-L Page 2
Picture phase	6/TTV-TR-VS Page 3
PIV	3/2-C-AC-D Page 1
Plastic film capacitors	3/2-C-PC-C Page 5
Playback level adjustment	5/VCR-VCS-HiVT-34A Page 24
Pliers	4/1 Page 3
PLL tuning circuit	6/TTV-TR-T Page 7
PNP transistors	3/2-C-AC-T Page 2
Power	3/2-PVC Page 1
adjustment	5/VCR-VCS-HiVT-34A Page 19
supply problems	7/R-TR-Ch Page 1
Power supply	
measurements	9/PC-TR-PS Page 1
access	9/PR-TR-PS Page 1
Preforming solder leads	3/4 Page 2
Prescaler	7/R-TR-DTR Page 3
Prescaler circuit	4/3-F Page 6
Processor control diagram	10/TR-C Page 2
PTT/MOX transmitter codes	8/R-TR-T Page 2
Pulse and square wave	4/3-SS Page 5
Pulse generator	5/VCR-TR-CSP Page 3
Purity	6/TTV-VCS-Mag T985/T986 Page 10

## Q

Quantities	3/2-QUS Page 1
------------	----------------

## R

R and B signal	
gain preset	5/Cam-TR-EA-C Page 2
separation preset	5/Cam-TR-EA-C Page 2
shading preset	5/Cam-TR-EA-C Page 2
shading release	5/Cam-TR-EA-C Page 1

R-C circuits	4/3-SS Page 2
R-S bistable	3/2-C-AC-L Page 7
Radio	
AM Tuners	7/R-F-T-AMT
antenna	7/R-F-A
circuit Tests	7/R-TR-CT
digitally Tuned Radios	7/R-TR-DTR
FM Tuners	7/R-F-T-FMT
modulation	7/R-F-M
receivers	7/R-TR-R
transceivers	7/R-TR-T
troubleshooting and repair	7/R-TR
RAM	9/PC-AM Page 2
Random noise generator	4/3-SS Page 11
Ratio	
detectors	6/TTV-TR-AS Page 4
measurement waveform	4/3-F Page 5
Rear defogger	8/TR-R Page 2
Receiver	
case study	7/R-VCS-Tech ST-S8 Pages 1-12
IF amplifier oscillation tests	7/R-TR-R Page 1
oscillator checking	7/R-TR-R Page 1
Record bias level adjustment	5/VCR-VCS-HiVT-34A Page 24
Reel	
disk height adjustment	5/VCR-VCS-HiVT-34A Pages 10-11
table height	5/VCR-TR-MA-HA Page 1
Reference oscillation adjustment	5/VCR-VCS-HiVT-34A Page 21
Reflectometers	7/R-TR-A Page 1
Refrigerator	
basic parts	10/TR-A/C•R-A Page 3
electrical problems	10/TR-A/C•R-EP Page 1
mechanical problems	10/TR-A/C•R-MP Page 1
refrigeration basics	10/TR-A/C•R-A Page 2
Rejection ratio	3/2-C-AC-Op Amp Page 3
Remote control cleaning	7/CD-M Page 7
Resin core	
solder	4/1 Page 15
Resistance	
checking circuit	4/3-DMM Page 5
substitution box	4/2 Page 6
substitution circuit	4/2 Page 7
Resistor	
accuracy	3/2-C-PC-R Page 1
color codes	3/2-C-PC-R Page 3
functions	3/2-C-PC-R Page 1
noise	3/2-C-PC-R Page 1
power rating	3/2-C-PC-R Page 1
replacement	3/2-C-PC-R Page 2
stability	3/2-C-PC-R Page 1
temperature	3/2-C-PC-R Page 1
values	3/2-C-PC-R Page 1
Reverse biased diode	3/2-C-AC-D Page 2
RF	
AGC adjustment	5/VCR-VCS-HiVT-34A Page 28
amplifier of mixer stage	6/TTV-TR-T Page 9
amplifier	7/R-F-T-FMT Page 2

selection	6/TTV-TR-T Page 1
systems troubleshooting	7/R-TR-A Page 1
Ribbon cable strippers	4/1 Page 6
Ringers/Buzzers/Bells	11/Tel-TR-SP Page 3
Ringing	6/TTV-TR-IFA Page 3
Rise time	4/3-O Page 12
ROM	9/PC-AM Page 1
Rotary	
dial	11/Tel-TR-SP Page 2
magnet assembly	5/VCR-VCS-HiVT-34A Page 34

## S

Safety warnings	2/3 Page 1
Sample/hold offset adjustment	7/CD-TR-DM Page 1
Sampling and oversampling	7/CD-F-CDPD Page 5
Scale of Integration	3/2-C-AC-IC Page 2
Scan tool	8/TR-ECM Page 1
Scanning process	11/F-A Page 2
Schmitt trigger	4/3-F Page 3
Screwdrivers	4/1 Page 8
Second detector	7/R-F-T-AMT Page 3
Selectivity	6/TTV-TR-IFA Page 1
Servo	
problems	5/VCR-TR-CSP Page 2
terminals/box	8/A Pages 2-3
timing chart	5/VCR-TR-CSP Page 2
Sharp VL-L285U	
adjustments	5/Cam-VCS-Sha-VL-L285U Pages 16-27
disassembly	5/Cam-VCS-Sha-VL-L285U Pages 4-8
overview	5/Cam-VCS-Sha-VL-L285U Pages 1-2
Shock victim	2/3 Page 4
Side cutter	4/1 Page 2
SIF adjustment	5/VCR-VCS-HiVT-34A Page 27
Signal	
generating devices	4/3-SS Page 6
injection	8/TR-PS-CS Page 3
problems	7/R-TR-Ch Page 2
processing circuits	7/CD-TR-SP/AC Pages 1-2
tracer	4/2 Page 6
tracing in a simple receiver	8/TR-PS-CS Page 2
Silicon diode	3/2-C-AC-D Page 3
Simple electronic phone	11/Tel-TR-SP Page 5
Sine wave	4/3-O Page 15
Sine wave parameters	3/2-PVC Page 4
Single and multilayer inductors	3/2-C-PC-I Page 4
Slew rate	3/2-C-AC-Op Amp Page 3
Small gripping tools	4/1 Page 4
Solder	
joint	3/4 Pages 1,4
thickness	3/4 Page 1
types	3/4 Page 1
Soldering	
checklist	3/4 Page 4
pencil	4/1 Page 13

tips	4/1 Page 14
Soldersucker	3/4-D Page 2
Solid state	4/1 Page 17
Sound module	6/TTV-VCS-Mag T985/T986 Page 8
Sound IF alignment	6/TTV-VCS-Mag T985/T986 Page 7
Special security head	4/1 Page 9
Square-wave generator	4/3-SS Page 14
Squelch	7/R-F-T-AMT Page 5
circuit	7/R-F-T-AMT Page 6
Standard	
linear audio	5/VCR-TR-AP-R Page 1
resistors	4/1 Page 17
Static convergence	6/TTV-VCS-Mag T985/T986 Page 10
Stereo amplifier power check	7/R-TR-R Page 6
Stethoscope	4/1 Page 13
Stripe filter characteristics	5/Cam-TR-VP-R Page 2
Subcode	7/CD-F-CDD Page 7
Substitution box	4/2 Page 3
Supply voltages	3/2-C-AC-L Page 10
Surgical clamps	4/1 Page 4
SVHS	5/Cam-A Page 1
SVHS-C	5/Cam-A Page 1
Sweep	
error	4/3-SS Page 9
generator	6/TTV-TE-TV/V Page 11
Sweep-frequency generator	4/3-SS Page 7
Switch lever pin alignment	5/VCR-VCS-HiVT-34A Page 30
Symbols	3/2-QUS Pages 4-10
Synchronization bits	7/CD-F-CDD Page 7
System check	8/TR-ECM Page 4

## T

Table guidepost adjustment	5/VCR-TR-MA-HA Page 1
Take-up and supply reels	5/VCR-VCS-HiVT-34A Page 40
Tantalum capacitors	3/2-C-PC-C Page 5
Tape counter	
capacitance	5/Cam-TR-VP-TCC Page 2
controls	5/Cam-TR-VP-TCC Page 2
memory	5/Cam-TR-VP-TCC Page 2
display	5/Cam-TR-VP-TCC Page 1
Tape	
transport system	5/VCR-VCS-HiVT-34A Page 9
transport	5/VCR-TR-MA-TT Page 1
TDA1085A motor speed controller	10/TR-ECM Page 3
Technics ST-S8	
adjustments	7/R-VCS-Tech ST-S8 Pages 1-7
ICs	7/R-VCS-Tech ST-S8 Pages 8-12
Telephone	
cordless phones	11/Tel-TR-CP Page 1
standard phones	11/Tel-TR-SP Page 1
telephone line	11/Tel-TR-TL Page 1
Tension	
adjustments	5/VCR-TR-MA-TA Page 1
band assembly	5/VCR-VCS-HiVT-34A Page 39

control adjustment	11/C-TR Page 3
pole adjustment	5/VCR-VCS-HiVT-34A Page 12
Test	
charts	6/TTV-TE-TV/V Page 13
light for automobile	8/TR-PS-CS Page 1
phone	11/Tel-TE Page 1
socket configuration	4/2 Page 10
tapes	5/VCR-TE Page 1
Test equipment	
audio codes	9/PC-TE Page 4
automatic	9/PC-TE Page 2
breakout box	9/PC-TE Page 1
CPU simulator	9/PC-TE Page 3
diagnostic software	9/PC-TE Page 4
disk drive exerciser	9/PC-TE Page 4
IC tester	9/PC-TE Page 3
logic clip	9/PC-TE Page 2
logic comparator	9/PC-TE Page 2
signature analyzer	9/PC-TE Page 3
Thermostats	
bimetallic strip	10/TR-Th Page 1
heat coil	10/TR-Th Page 2
heat sensing	10/TR-Th Page 2
testing	10/TR-Th Page 2
thermistor/varistor	10/TR-Th Page 2
thermocouple device	10/TR-Th Page 2
Thyristor casing	3/2-C-AC-Thy Page 2
Throttle position sensor circuit 21	8/TR-ECM-CL Page 2
Throttle position sensor circuit 22	8/TR-ECM-CL Page 3
Thyristors	3/2-C-AC-Thy Page 1
Time interval measurement	4/3-F Page 4
Time measurement	4/3-O Page 10
Timers	3/2-C-AC-Ti Page 1
Tone generator	11/Tel-TE Page 1
Tools for repair	4/1 Page 1
Toroidal yoke windings	6/TTV-TR-CPT Page 1
Torque	
checks	5/VCR-TR-MA-TC Page 1
converter	8/TR-R Page 2
Torx head	4/1 Page 9
Totalizing measurement	4/3-F Page 6
Touch tone dial	11/Tel-TR-SP Page 2
Tracking servo offset	7/CD-TR-L Page 3
Tracking preset	5/Cam-TR-EA-BC Page 4
Transceiver	
alignment	8/R-TR-T Page 2
switching control problems	8/TR-PS-CS Page 1
Transformer	
characteristics	3/2-C-PC-T Page 1
construction	3/2-C-PC-T Page 3
formulas	3/2-C-PC-T Page 3
functions	3/2-C-PC-T Page 1
replacement	3/2-C-PC-T Page 4
symbols	3/2-C-PC-T Page 2
terminals	5/VCR-VCS-HiVT-34A Page 34
testing	10/TR-T Page 1



Transistor	
checkers	4/2 Page 8
coding	3/2-C-AC-T Page 5
hFE measuring	4/3-DMM Page 7
Transmitter	
frequency counters	7/R-TR-A Page 1
power supplies	7/R-TR-A Page 2
Triac casings	3/2-C-AC-Tr Page 2
Triacs	3/2-C-AC-Tr Page 1
Trigger input	4/3-O Page 5
Troubleshooting	
approach	3/3 Page 1
block diagrams	3/3 Pages 4-5
circuit diagram	3/3 Pages 6-13
component identification	3/3 Page 15
flow chart	3/3 Page 2
substitution	3/3 Pages 16-19
Truth tables	3/2-C-AC-L Page 2
TSW signal	7/CD-TR-DM Page 2
TTL devices	3/2-C-AC-L Page 9
Tube testers	4/2 Page 11
Tuner/IF circuit	5/VCR-VCS-HiVT-34A Page 24
Tuner	
case study	7/T-VCS-ZXP Pages 1-12
diagnosis and repair	6/TTV-TR-T Page 7
Turret tuners	6/TTV-TR-T Page 4
TV	
alignment	6/TTV-VCS-Mag T985/T986 Page 5
audio	6/TTV-TR-AS Pages 1-2
color problems	6/TTV-TR-AS Page 1
crosstalk	6/TTV-TR-PS Page 1
frequency spectrum	6/TTV-TE-TV/V Page 4
humming	6/TTV-TR-PS Page 1
picture problems	6/TTV-TE-TV/V Page 1
poor color	6/TTV-TR-T Page 10
receiver block diagram	6/TTV-TE-TV/V Page 6
sound missing	6/TTV-TR-IFA Page 2
standards	6/TTV-TE-TV/V Page 3
testing procedures	6/TTV-TE-TV/V Page 3
troubleshooting flow chart	6/TTV-TE-TV/V Page 2
waveform monitors	6/TTV-TE-TV/V Page 1
weak sound	6/TTV-TR-PS Page 1
Typical IF stage block diagram	6/TTV-TR-IFA Page 2

## U

UHF tuner	6/TTV-VCS-Mag T985/T986 Page 14
UM3482A doorbell music chip	10/TR-T Page 4
Units	3/2-QUS Page 2
Upper cylinder	5/VCR-VCS-HiVT-34A Page 30

## V

Vacuum	
--------	--

cruise control	8/TR-ECM-CC Page 1
supply test	8/TR-ECM-CC Page 2
Variable	
capacitors	3/2-C-PC-C Page 6
resistors	3/2-C-PC-R Page 4
VCR	
cleaning procedure	5/VCR-A-VHS Page 2
cover screw positions	5/VCR-A-VHS Page 3
external cleaning	5/VCR-A-VHS Page 1
internal cleaning	5/VCR-A-VHS Page 1
lubrication	5/VCR-A-VHS Page 3
luminance circuit	5/VCR-TR-VP-FPC Page 1
recording patterns	5/VCR-TR-VP-R Page 1
Vectorscope	6/TTV-TE-TV/V Page 3
Vectorscope waveform monitor	5/VCR-TE Page 1
Vehicle speed sensor circuit 24	8/TR-ECM-CL Page 3
Ventilation	3/1 Page 2
Vertical deflection circuits	6/TTV-TR-DC Page 1
Vertical/horizontal centering	6/TTV-VCS-Mag T985/T986 Page 13
VHF tuner	6/TTV-VCS-Mag T985/T986 Page 14
VHS-C	5/Cam-A Page 1
Vibration	7/CD-F-CDPD Page 7
Video	
analyzer	5/VCR-TE Page 1
IF alignment	6/TTV-VCS-Mag T985/T986 Page 5
monitor	5/VCR-TE Page 1
output level adjustment	5/VCR-VCS-HiVT-34A Page 27
problems	6/TTV-TR-DC Page 2
Videomatic	
module	6/TTV-VCS-Mag T985/T986 Page 12
range adjustment	6/TTV-VCS-Mag T985/T986 Page 11
Videotape	5/VCR-A-VHS Page 2
Voltage regulator	
casings	3/2-C-AC-VR Page 5
circuits	3/2-C-AC-VR Page 3
Voltage	
divider	4/2 Page 3
regulators	3/2-C-AC-Tr Page 1
VOX control	8/TR-PS-CS Page 1

## W

Wafer tuner	6/TTV-TR-T Page 3
Watt meter	7/R-TR-A Page 1
Waveform	
analysis	4/3-O Page 14
jitter measurement	4/3-O Page 11
phase shift	4/3-O Page 12
Waveforms	3/2-PVC Page 3
White balance circuit	5/Cam-TR-VP-CC Page 3
Wien bridge oscillator	4/3-SS Page 2
Wire	
cutters	4/1 Page 1
stripping tools	4/1 Page 5

**Wiring**

circuit amperage	10/A-W Page 1
color coding	10/A-W Page 5
electrical load	10/A-W Page 1
low voltage	10/A-W Page 6
NEC	10/A-W Page 1
rating	10/A-W Page 1
receptacles	10/A-W Page 2
sizing	10/A-W Page 4
stranding	10/A-W Page 5
Work station supply	4/2 Page 2
Workplace power supply	4/2 Page 2

**Y**

Y/C circuit	5/VCR-VCS-HIVT-34A Page 23
Yoke	6/TTV-TR-CPT Page 2

**Z**

Zener diodes	3/2-C-AC-D Page 4
Zenith XP Tuner	
alignment	7/T-VCS-ZXP Pages 5-11
audio/power supply schematic	7/T-VCS-ZXP Page 3
general troubleshooting	7/T-VCS-ZXP Page 1
RF/IF/MPX schematic	7/T-VCS-ZXP Page 4
Zoom motor control circuit	5/Cam-TR-VP-CC Page 2

**12/I**

**Indices**

---

12/I - ERM

---

Electronics Repair Manual

---

---

# 12/I

## Indices

12/I - IC

Integrated Circuits

12/I - IC - A

Audio Devices

## 12/I - IC - A

### Audio Devices

Device	Part Number	Manufacturer	Description	Notes
110	M110	SGS-Thompson	Synthesizer	Monophonic
112	M112	SGS-Thompson	Synthesizer	Polyphonic
200	TBB200	Siemens	Freq. synthesizer	Phase locked loop
206	TBB206	Siemens	Frequency synthesizer	PLL with 3 line bus
210	XR210	Exar	FSK Modulator/Demod.	FM circuits
215	XR215	Exar	Phase locked loop	FM circuits
262	CS262	Cherry Semi.	Speaker phone	
272	CS272	Cherry Semi.	Speaker phone	
326	IR3R26	Sharp	AM receiver	
381	IR3N81A	Sharp	Speaker phone	
383	IR3N83	Sharp	Speaker phone	Speech network
384	IR3N84	Sharp	Speaker phone	Preset volume
406	MX406	MX-COM	Phase locked loop	FM circuits
415	ZN415E	Plessey	AM receiver	
416	ZN416	Plessey	AM receiver	
440	TCA440	Siemens	AM receiver	
469	TBB469	Siemens	FM receiver	
564	SE564 NE564	Signetics Signetics	Phase locked loop Phase locked loop	FM circuits FM circuits
567	SE567 LM567C XR567C XR567AC NE567 LM567C LM567	Signetics Samsung Exar Exar Signetics National National	Tone decoder Tone decoder Tone decoder Tone decoder Tone decoder Tone decoder Tone decoder	Phase locked loop Phase locked loop Phase locked loop Phase locked loop Phase locked loop Phase locked loop Phase locked loop
568	NE568 LMC568	Signetics National	Phase locked loop Phase locked loop	FM circuits Demodulates FM/FSK
600	SAB0600	Siemens	Music chimes	

## Section 12 • Reference Materials

# 12/I

## Indices

12/I - IC

Integrated Circuits

12/I - IC - A

Audio Devices

Device	Part Number	Manufacturer	Description	Notes
601	SAB0601	Siemens	Music chimes	
602	SAB0602	Siemens	Music chimes	
604	NE604A	Signetics	FM radio	Quadrature detector, signal strength
605	NE605	Signetics	AM/FM receiver	Quadrature detector, signal strength, clock
615	NE615	Signetics	AM/FM receiver	
623	SL623C	Plessey	SSB detector	AM single sideband
652	SL652	Plessey	Phase locked loop	FM circuits
758	$\mu$ A758	Signetics	FM stereo decoder	
1057	SAA1057	Signetics	AM/FM tuner	Tuning synthesizer
1062	TDA1062S	AEG Corp	FM tuner	
1083	TDA1803	AEG Corp	AM/FM receiver	
1099	SAA1099	Signetics	Sound generator	Stereo sound effects
1112	LM1112A LM1112B LM1112C	National National National	Dolby processor Dolby processor Dolby processor	B-type noise reduction B-type noise reduction B-type noise reduction
1137	LA1137	Sanyo	AM radio	AM IF circuit
1212	F1212	National	Modem	Bell 103/212A
1220	TDA1220L TDA1220A	SGS-Thompson SGS-Thompson	AM/FM receiver AM/FM receiver	
1240	LS1240 LA1240	SGS-Thompson Sanyo	Telephone tone ringer AM tuner	Same as MC34012
1245	LA1245	Sanyo	AM tuner	
1262	CH1262	Cermetek	Modem	Bell 103/113
1267	CH1267	Cermetek	Modem	Bell 103/113
1276	$\mu$ PD1276G	NEC	FM radio	FM front end
1280	CH1280	Cermetek	Modem	Bell 103/113
1287	$\mu$ PD1287	NEC	FM radio	Stereo demodulator
1310	LM1310	National	FM stereo decoder	
1322	$\mu$ PD1322	NEC	AM receiver	
1330	TEA1330	SGS-Thompson	FM stereo decoder	
1344	$\mu$ PD1344	NEC	AM receiver	

Section 12 • Reference Materials

**12/I**  
**Indices**

12/I - IC

Integrated Circuits

12/I - IC - A

Audio Devices

Device	Part Number	Manufacturer	Description	Notes
1469	TBB1469	Siemens	FM receiver	
1496	SG1496 MC1496 LM1496 LM1496 SL1496	Silicon Gen. Motorola Signetics National Plessey	Modulator/demodulator Modulator/demodulator Modulator/demodulator Modulator/demodulator Modulator/demodulator	FM, balanced mod/demod (See MC1596) FM, balanced mod/demod (See MC1596) FM, balanced mod/demod (See MC1596) FM, balanced mod/demod (See MC1596) FM, balanced mod/demod (See MC1596)
1524	TDA1524A MC1524A	Motorola Motorola	Stereo tone control AM/FM radio	Balance, volume, trebel, bass Stereo tone control
1572	TDA1572	Signetics	AM receiver	IF output
1574	TUA1574	Siemens	AM/FM tuner	
1578	TDA1578A	Signetics	FM stereo decoder	
1596	MC1596	Motorola	Modulator/demodulator	Wide temperature version of MC1496
1658	SP1658	Plessey	VCO	Voice controlled oscillator
1760	CH1760	Cermetek	Modem	Bell 212A
1763	CH1763	Cermetek	Modem	Bell 212A
1765	CH1765	Cermetek	Modem	Bell 212A
1770	CH1770	Cermetek	Modem	Bell 212A
1800	LM1800	National	FM stereo decoder	
1866	LM1866	National	AM/FM receiver	
1870	LM1870	National	FM stereo decoder	
1891	CH1891	Cermetek	Modem	MNP error level 4
1892	CH1892	Cermetek	Modem	MNP error level 5 (data compression)
1992	LMC1992	National	Stereo FM radio	Digital tone/volume, 4 channel input
2009	2009Z	NCM	Melody circuit	Used in clocks
2112	SDA2112-2	Siemens	Phase locked loop	FM circuits
2121	SDA2121 XR2121	Siemens Exar	AM/FM tuner Modem	Phase lock loop Modulator, Bell 212A
2122	XR2122	Exar	Modem	Demodulator, Bell 212A
2130	XR2130	Exar	Modem	Bell 212A, CCITT V.22
2204	ULN2204A	Allegro Micro	AM/FM receiver	
2211	XR2211C XR2211C	Raytheon Exar	Tone decoder Tone decoder	Phase locked loop Phase locked loop
2213	XR2213C	Exar	Tone decoder	Phase locked loop

## Section 12 • Reference Materials

# 12/I

Indices

12/I - IC

Integrated Circuits

12/I - IC - A

Audio Devices

Device	Part Number	Manufacturer	Description	Notes
2241	ULN2241C	Allegro Micro	AM/FM receiver	
2243	KA2243	Samsung	AM/FM radio	IF system
2244	KA2244	Samsung	FM radio	Stereo
2245	KA2245	Samsung	FM radio	Stereo
2249	KA2249	Samsung	FM radio	FM front end, portable radios
2418	KA2418	Samsung	Telephone tone ringer	Same as MC34012
2469	TBB2469	Siemens	FM receiver	
2559	UMC2559	UNC	Tone dialer	
2770	LA2770	Sanyo	Dolby processor	Surround sound
2831	MC2831A MC2831	Motorola Motorola	FM transmitter FM/FSK transmitter	FM/FSK 50 MHz, low battery check, tone osc.
2833	MC2833 MC2833 μPD2833	Motorola Motorola NEC	FM transmitter FM/FSK transmitt Phase locked loop	FM/FSK r150 MHz, 2 freq. multiplier/amps
2834	μPD2834	NEC	Phase locked loop	
3022	YM3022	Yamaha	4800 modem	Analog-digital interface
3088	CA3088	Harris	AM receiver	
3105	TCM3105	TI	Modem	Bell 202/CCITT V.23
3195	CA3169	Harris	FM stereo decoder	
3200	NJU3200	NJR	Freq. synthesizer	Phase locked loop, AM/FM radio
3240	LS3240	SGS-Thompson	Telephone tone ringer	Same as MC34017
3356	MC3356	Motorola	RF receiver	Wideband data, FM/FSK, VHF. 500Kb rate
3357	MC3357	Motorola	FM IF	Narrowband
3359	MC3359	Motorola	FM IF	Low power narrowband
3361	MC3361 MC3361B LA3361	Signetics Motorola Sanyo	AM/FM receiver FM IF FM stereo decoder	Low voltage narrowband
3362	MC3362	Motorola	VHF/FM receiver	Dual conversion, mute I/O
3363	MC3363	Motorola	FM receiver	Dual conversion
3365	LA3365 MC3365	Sanyo Motorola	FM stereo decoder RF receiver	Narrowband dual conversion, FM/FSK, VHF
3367	MC3367	Motorola	FM receiver	Low voltage narrowband



Section 12 • Reference Materials

**12/1**  
**Indices**

12/1 - IC

Integrated Circuits

12/1 - IC - A

Audio Devices

Device	Part Number	Manufacturer	Description	Notes
3370	LA3370	Sanyo	FM stereo decoder	
3371	MC3371	Motorola	FM IF	Narrowband
3375	LA3375	Sanyo	FM stereo decoder	
3419	MC3419-1L	Motorola	Telephone interface	Subscriber loop interface
3459	NCM3459Z	NCM	Alarm clock radio	
3530	MT3530	Mitel	Modem	Bell 103/113
3615	GL3615	Goldstar	Play/record circuit	VCR audio circuit
3839	ULN3839A	Allegro Micro.	AM receiver	
3910	PBM3410	Ericsson	Speaker phone	
3911	PBM3411	Ericsson	Speaker phone	
4010	TDA4010	Siemens	AM receiver	AM stereo
4046	CD4046 CD4046BC F4046 CD4046B CD4046BN CD4046BE HCF4046 HCC4046	National National National Harris National Harris SGS-Thompson SGS-Thompson	Phase locked loop Phase locked loop Phase locked loop Phase locked loop Phase locked loop Phase locked loop Phase locked loop Phase locked loop	CMOS, FM circuits (replaces MC14046) CMOS, FM circuits CMOS, FM circuits (replaces MC14046) CMOS, FM circuits (replaces MC14046) CMOS, FM circuits CMOS, FM circuits CMOS, FM circuits CMOS, FM circuits (replaces MC14046) CMOS, FM circuits (replaces MC14046)
4105	MB4105	Fujitsu	FM radio	Stereo multiplex demodulator
4500	TCA4500A LM4500A	Motorola National	FM stereo decoder FM stereo decoder	
4511	TCA4511-1	Siemens	Stereo decoder	Phase locked loop
5206	KS5206	Samsung	Alarm clock	
5207	KS5207	Samsung	Alarm clock	
5310	KS5310A KS5310C	Samsung Samsung	Melody circuit Melody circuit	Used in clocks Used in clocks
5313	KS5313	Samsung	Melody circuit	Used in clocks
5314	KS5314	Samsung	Melody circuit	Used in clocks
5340	KS5340C	Samsung	Melody circuit	Used in clocks
5380	KS5380A	Samsung	Melody circuit	Used in clocks
5390	KS5390	Samsung	Sound generator	Organ
5570	TEA5570	Signetics	AM/FM receiver	
6057	TSA6057	Signetics	AM/FM tuner	Digital tuning synthesizer

## Section 12 • Reference Materials

# 12/I

Indices

12/I - IC

Integrated Circuits

12/I - IC - A

Audio Devices

Device	Part Number	Manufacturer	Description	Notes
6103	NJU6103	NJR	Freq. synthesizer	Phase locked loop, CB radio
6200	TEA6200	Signetics	AM receiver	
6420	XR6420 XR6420-2	Exar Exar	Speaker phone Speaker phone	Two chip set, with XR6421
6421	XR6421	Exar	Speaker phone	Two chip set, with XR6420
6425	XR6425	Exar	Speaker phone	
6652	SL6652C	Plessey	FM radio	Quadrature detector, signal strength
6653	SL6653C	Plessey	FM radio	Quadrature detector, signal strength
6691	SL6691C	Plessey	FM radio	FM IR, PLL, RF mixer
6700	SL6700C SL6700A	Plessey Plessey	AM radio AM radio	AM IF and detector AM IF and detector
7000	TDA7000	Signetics	FM receiver	
7001	LC7001	Sanyo	Phase locked loop	NMOS, radio receiver
7010	TDA7010T	Signetics	FM receiver	
7021	TDA7021T	Signetics	FM radio	Single chip radio
7109	YM7109	Yamaha	Fax modem	9600 bps
7157	TA7157A	Toshiba	FM stereo decoder	
7217	LC7217	Sanyo	Phase locked loop	CMOS, radio receiver
7218	LC7218	Sanyo	Phase locked loop	CMOS, radio receiver
7342	TA7342	Toshiba	FM stereo decoder	
7401	TA7401A	Toshiba	FM stereo decoder	
7402	TA7402	Toshiba	AM tuner	Car radio
7515	TS7515	SGS-Thompson	Modem	Bell 212A, CCITT V.22, DPSK
7613	TA7613A	Toshiba	AM/FM receiver	
7616	TA7616	Toshiba	AM tuner	Car radio
7641	TA7641B	Toshiba	AM receiver	
7911	AM7911	AMD	Modem	Bell 103/113/108/202. CCITT V.21/V.23
8361	LM8361	Sanyo	Alarm clock	
8364	LM8364	Sanyo	Alarm clock radio	
9422	STC9422	S-MOS	300 modem	Bell 103

## Section 12 • Reference Materials

# 12/I

## Indices

12/I - IC

Integrated Circuits

12/I - IC - A

Audio Devices

Device	Part Number	Manufacturer	Description	Notes
9424	STC9424C	STC	300 modem	Bell103, power-down mode
9559	UMC9559E	UMC	Tone dialer	
9646	MSM9646	OKI	300 modem	Bell 103
9647	MSM9647	OKI	1200 modem	Bell 103
11002	SC11002	Sierra	Modem	Bell 103
11003	SC11003	Sierra	Modem	Bell 103, -5 volts
11004	SC11004	Sierra	Modem	Bell 103/212A, CCITT V.21/V.22
11006	SC11006	Sierra	Modem	Bell 103/212A, CCITT V.21/V.22, V.22 bis
11007	SC11007	Sierra	Modem controller	Used with 300/1200 modems
11008	SC11008	Sierra	Modem controller	Used with 300/1200 modems
11011	SC11011	Sierra	Modem controller	Used with SC11006 modem
11013	SC11013	Sierra	Modem controller	Used with SC11006 modem, 2400 MNP
11014	SC11014	Sierra	Modem	Bell 103/212A, CCITT V.21, V.22
11015	SC11015	Sierra	300/1200 modem	Bell 103/212A, CCITT V.21, V.22
11016	SC11016	Sierra	300/1200 modem	Bell 103/212A, CCITT V.21/V.22
11017	SC11017	Sierra	Modem controller	Used with SC11004/11014/11015 modems
11019	SC11019	Sierra	Modem controller	Used with SC11006 modem, 2400 MNP
11020	SC11020	Sierra	Modem controller	Used with 300/1200 modems
11027	SC11027	Sierra	Modem controller	Used with SC11016 modem
11028	SC11028	Sierra	Modem controller	Used with SC11016 modem
11030	SC11030	Sierra	Fax modem	Analog front end
11033	SC11033	Sierra	Modem, high speed	V.26, V.27, V.29, V.33
11037	SC11037	Sierra	Modem controller	Used with SC11016 modem
12062	HD12062	Hitachi	PLL data strobe	Digital audio tape systems
13020	MC13020	Motorola	AM decoder	Stereo decoder
13022	MC13022	Motorola	AM stereo decoder	Used with MC 13023 receiver/tuner
13023	MC13023	Motorola	AM receiver/tuner	Companion to MC13022 stereo decoder Stereo with tuner stabilizer
13024	MC13024	Motorola	AM stereo receiver	For manually tuned portable radios
13041	MC13041	Motorola	AM receiver	Front end for electronic tuned radios

## Section 12 • Reference Materials

# 12/I

## Indices

12/I - IC

Integrated Circuits

12/I - IC - A

Audio Devices

Device	Part Number	Manufacturer	Description	Notes
13055	MC13055	Motorola	FM IF	Wideband data, 40 MHz
14046	MC14046BC MC14046BA	Motorola Motorola	Phase locked loop Phase locked loop	CMOS, FM circuits CMOS, FM circuits
14412	MC14412 XR14412A	Motorola Exar	Modem Modem	FSK FSK
22212	CD22212E	Harris	Modem	Bell 212A
22421	KA22421	Samsung	AM receiver	Single chip radio
22424	KA22424	Samsung	AM/FM radio	One chip radio
22427	KA22427	Samsung	AM/FM radio	One chip radio
22441	KA22441	Samsung	FM radio	Stereo
22461	KA22461	Samsung	AM receiver	Tuner system (converter, IF amp)
32210	NS32FX210	National	Fax/modem	Analog front end with filter
33120	MC33120	Motorola	Telephone interface	Subscriber loop, PBX34114, MC34114A
34010	MC34010	Motorola	Telephone circuit	Electronic telephone functions
34011	MC34011A	Motorola	Telephone circuit	Electronic telephone functions
34012	MC34012	Motorola	Telephone tone ringer	Telephone bell functions
34013	MC34013A	Motorola	Phone speech/dialer	Tone dialer
34014	MC34014A	Motorola	Phone speech/dialer	Pulse/tone dialer
34017	MC34017	Motorola	Telephone tone ringer	MC34012 plus input current mirror
34018	MC34018	Motorola	Speakerphone	Line powered operation, voice switched
34114	MC34114	Motorola	Phone speech/dialer	Pulse/tone dialer, microphone amp
34117	MC34117	Motorola	Telephone tone ringer	MC34012 minus on-chip diode bridge
34118	MC34118	Motorola	Speakerphone	MC34018 plus filter/dial tone detect
34214	MC34214A	Motorola	Phone speech/dialer	Pulse/tone dialer, microphone amp
35103	TC35103	Toshiba	Fax modem	Analog front end, G2 and G3
35108	TC35108	Yamaha	Fax modem	9600 bps, half duplex
35180	TC35180	Toshiba	Fax	Pixel processor
49202	HD49202	Hitachi	Tape filter	Digital audio tape systems
54932	MM54C932	National	Phase comparator	FM circuits
58142	MM58142	National	Digital radio tuner	
66330	M66330	Misubishi	Fax controller	Band compression/expansion

Section 12 • Reference Materials

**12/I**  
**Indices**

12/I - IC

Integrated Circuits

12/I - IC - A

Audio Devices

Device	Part Number	Manufacturer	Description	Notes
66332	M66332	Misubishi	Fax controller	Graphics processing
68950	TS68950	SGS-Thompson	Modem	Analog front end
68951	TS68951	SGS-Thompson	Modem	Analog front end
68952	TS68952	SGS-Thompson	Modem	Analog front end, xmit/receive, clock
73212	SSI73K212 SSI73K212U	Silicon Syst. Silicon Syst.	Modem Modem/UART	Bell 103/212A SSI73K212 with async receiver/xmitter
74124	SN74S124	TI	VCO	Voice control oscillator, dual
74297	SN74LS297	TI	Phase locked loop	FM circuits
74624	SN74S624	TI	VCO	Voice controlled oscillator
74625	SN74SL625	TI	VCO	Dual channel
74628	SN74S628	TI	VCO	
74629	SN74SL629	TI	VCO	Dual channel
74932	MM74C932	National	Phase comparator	FM circuits
74942	MM74HC942	National	Modem	Bell 103/113
79101	AM79101	AMD	Modem, autodial	FSK, Bell103/113/108. CCITT V.21
87002	MB87002	Fujitsu	1200 modem	MSK (minimum shift keying)
88561	MB88561	Fujitsu	AM/FM tuner	Digital tuner
88562	MB88562	Fujitsu	AM/FM tuner	Digital tuner
91210	UMC91210	UMC	Phone dialer	Pulse/tone
91214	UMC91214	UMC	Phone dialer	Pulse/tone
91215	UMC91215	UMC	Phone dialer	Pulse/tone
91230	UMC91230C	UMC	Phone dialer	Pulse/tone
91260	UMC91260	UMC	Phone dialer	Pulse/tone, 10 number memory
91261	91261	UMC	Phone dialer	Pulse/tone, 10 number memory
91270	UMC91270	UMC	Phone dialer	Pulse/tone, 20 number memory
91271	UMC91271	UMC	Phone dialer	Pulse/tone, 20 number memory
91272	UMC91272	UMC	Phone dialer	Pulse/tone, 20 number memory
91311	UMC91311	UMC	Phone dialer	Pulse/tone
91531	UMC91531	UMC	Phone dialer	Pulse/tone, parallel input
95088	UMC95088	UMC	Tone dialer	

12/I - IC	Integrated Circuits
12/I - IC - A	Audio Devices

Device	Part Number	Manufacturer	Device	Notes
95089	UMC95089	UMC	Tone dialer	
145443	MC145443	Motorola	300 modem	Bell 103
153202	HD153202	Hitachi	Synthesizer	Phase locked loop, 100 MHz
732291	SSI73D2291	Silicon Syst.	Fax	TIA/EIA interface
732292	SSI73D2292	Silicon Syst.	Fax	TIA/EIA interface
732331	SSI73D2331	Silicon Syst.	Fax	V.17
732332	SSI73D2332	Silicon Syst.	Fax	V.17
744046	74HC4046A	Signetics	Phase locked loop	CMOS, FM circuits
747046	74HCT7046A 74HC7046A	Signetics Signetics	Phase locked loop Phase locked loop	CMOS, FM circuits CMOS, FM circuits

# 12/I

## Indices

12/I - PC

Personal Computers

12/I - PC - POST

POST Screen Error Messages

## 12/I - PC

### Personal Computers

## 12/I - PC - POST

### POST Screen Error Messages

Code	Description	Code	Description
01x	Undetermined problem errors.	161	System options not set-(run SETUP); dead battery.
02x	Power supply errors.	162	System options not set-(run SETUP); CMOS checksum/configuration error.
1xx	System board errors.	163	Time & date not set (run SETUP); clock not updating.
101	System board error; Interrupt failure.	164	Memory size error-(Run SETUP); CMOS setting does not match memory.
102	System board error; Timer failure.	165	PS/2 System options not set.
103	System board error; Timer interrupt failure.	166	PS/2 Micro channel adapter time-out error.
104	System board error; Protected mode failure.	199	User indicated INSTALLED DEVICES list is not correct
105	System board error; Last 8042 command not accepted.	2xx	Memory (RAM) errors.
106	System board error; Converting logic test.	201	Memory test failure, error location will be displayed in hexadecimal.
107	System board error; Hot non-maskable interrupt test.	202	Memory address error, address lines 00-15.
108	System board error; Timer bus test.	203	Memory address error, address lines 16-13.
109	System board error; Memory select error.	215	PS/2 Motherboard memory failure.
110	PS/2 System Board Error; Parity check error.	216	PS/2 Motherboard memory failure.
111	PS/2 Memory adapter error.	3xx	Keyboard errors.
112	PS/2 MicroChannel arbitration error.	301	Keyboard did not respond to software reset or a stuck key failure was detected. If a stuck key was detected, the scan code for the key is displayed in hexadecimal.
113	PS/2 MicroChannel arbitration error.		
121	Unexpected hardware interrupts occurred.		
131	PC system board cassette port wrap test failure.		

Code	Description	Code	Description
302	System Unit Keylock is Locked.	607	Disk is write protected; drive error.
303	Keyboard or system unit error.	608	Bad command; drive error.
304	Keyboard or system unit error; keyboard clock high.	610	Disk initialization failure; track 0 bad.
305	PS/2 keyboard fuse (on system board) error.	611	Time-out; drive error.
4xx	Monochrome display adapter (MDA) errors.	612	Bad controller chip.
4xx	PS/2 System board parallel port errors.	613	Bad direct memory access; drive error.
401	Monochrome memory test, horizontal sync frequency test, or video test failure.	614	Bad direct memory access; boundary overrun.
401	PS/2 System board parallel port failure.	615	Bad index timing; drive error.
408	User indicated display attributes failure.	616	Drive speed error.
416	User indicated character set failure.	621	Bad seek; drive error.
424	User indicated 80x25 mode failure.	622	Bad cyclic redundancy check; drive error.
432	Parallel port test failure; monochrome display adapter.	623	Record not found; drive error.
5xx	Color Graphics Adapter (CGA) errors.	624	Bad address mark; drive error.
501	CGA memory test, horizontal sync frequency test, or video test failure.	625	Bad controller chip; seek error.
508	User indicated display attribute failure.	626	Disk data compare error.
516	User indicated character set failure.	7xx	8087, 80287, or 80397 math coprocessor errors.
524	User indicated 80x25 mode failure.	9xx	Parallel printer adapter errors.
540	User indicated 320x200 graphics mode failure.	901	Parallel printer adapter test failure.
548	User indicated 640x200 graphics mode failure.	10xx	Alternate parallel printer adapter errors.
6xx	Floppy drive/adaptor errors.	1001	Alternate parallel printer adapter test failure.
601	Floppy drive/adaptor power on self test failure.	11xx	Asynchronous communications adapter errors.
602	Drive test failure; disk boot record is not valid.	11xx	PS/2 System board async port errors.
606	Disk chainline function failure; drive error.	1101	Asynchronous communications adapter test failure.
		1102	PS/2 System board async port or serial device error.



Code	Description	Code	Description
1106	PS/2 System board async port or serial device error.	1233	PS/2 System board async port or system board error.
1107	PS/2 System board async port or serial cable error.	1234	PS/2 System board async port or system board error.
1108	PS/2 System board async port or serial device error.	13xx	Game control adapter errors.
1109	PS/2 System board async port or serial device error.	1301	Game control adapter test failure.
1112	PS/2 System board async port error.	1302	Joy-stick test failure.
1118	PS/2 System board async port error.	14xx	Matrix printer errors.
1119	PS/2 System board async port error.	15xx	Synchronous data link control (SDLC) communications adapter errors.
12xx	Alternate asynchronous communications adapter errors.	1510	8255 port B failure.
12xx	PS/2 Dual async adapter error.	1511	8255 port A failure.
1201	Alternate asynchronous communications adapter test failure.	1512	8255 port C failure.
1202	PS/2 System board async port or serial device error.	1513	8253 timer 1 did not reach terminal count.
1206	PS/2 System board async port or serial device error.	1514	8253 timer 1 stuck on.
1207	PS/2 System board async port or serial cable error.	1515	8253 timer 0 did not reach terminal count.
1209	PS/2 System board async port or serial device error.	1516	8253 timer 0 stuck on.
1212	PS/2 System board async port or system board error.	1517	8253 timer 2 did not reach terminal count.
1218	PS/2 System board async port or system board error.	1518	8253 timer 2 stuck on.
1219	PS/2 System board async port or system board error.	1519	8253 port B error.
1227	PS/2 System board async port or system board error.	1520	8273 port A error.
		1521	8273 command/read time-out.
		1522	Interrupt level 4 failure.
		1523	Ring Indicate stuck on.
		1524	Receive clock stuck on.
		1525	Transmit clock stuck on.
		1526	Test indicate stuck on.

Code	Description	Code	Description
1527	Ring indicate not on.	1781	Fixed disk 1 failure.
1528	Receive clock not on.	1782	Fixed disk controller failure.
1529	Transmit clock not on.	1790	Fixed disk 0 error.
1530	Test indicate not on.	1791	Fixed disk 1 error.
1531	Data set ready not on.	18xx	I/O expansion unit errors.
1532	Carrier detect not on.	1801	I/O expansion unit POST error.
1533	Clear to send not on.	1810	Enable/Disable failure.
1534	Data set ready stuck on.	1811	Extender card wrap test failure; disabled.
1536	Clear to send stuck on.	1812	High order address lines failure; disabled.
1537	Level 3 interrupt failure.	1813	Wait state failure; disabled.
1538	Receive interrupt failure.	1814	Enable/Disable could not be set on.
1539	Wrap data compare error.	1815	Wait state failure; disabled.
1540	Direct memory access channel 1 error.	1816	Extender card wrap test failure; enabled.
1541	Direct memory access channel 1 error.	1817	High order address lines failure; enabled.
1542	Error in 8273 error checking or status reporting.	1818	Disable not functioning.
1547	Stray interrupt level 4.	1819	Wait request switch not set correctly.
1548	Stray interrupt level 3.	1820	Receiver card wrap test failure.
1549	Interrupt presentation sequence time-out.	1821	Receiver high order address lines failure.
16xx	Display emulation errors (327x, 5520, 525x).	19xx	3270 PC attachment card errors.
17xx	Fixed disk errors.	20xx	Binary synchronous communications (BSC) adapter errors.
1701	Fixed disk adapter error.	2010	8255 port A failure.
1702	Fixed disk adapter error.	2011	8255 port B failure.
1703	Fixed disk drive error.	2012	8255 port C failure.
1704	Fixed disk adapter or drive error.	2013	8253 timer 1 did not reach terminal count.
1780	Fixed disk 0 failure.	2014	8253 timer 1 stuck on.

# 12/I

## Indices

12/I - PC

Personal Computers

12/I - PC - POST

POST Screen Error Messages

Code	Description	Code	Description
2015	8253 timer 2 did not reach terminal count or timer 2 stuck on.	2041	Data set ready not on.
2017	8251 Data set read failed to come on.	2042	Carrier detect not on.
2018	8251 Clear to send not sensed.	2043	Clear to send not on.
2019	8251 Data set read stuck on.	2044	Data set ready stuck on.
2020	8251 Clear to send struck on.	2045	Carrier detect struck on.
2021	8251 hardware reset failure.	2046	Clear to send stuck on.
2022	8251 software reset failure.	2047	Unexpected transmit interrupt.
2023	8251 software "error reset" failure.	2048	Unexpected receive interrupt.
2024	8251 transmit ready did not come on.	2049	Transmit data did not equal receive data.
2025	8251 receive ready did not come on.	2050	8251 detected overrun error.
2026	8251 could not force "overrun" error status.	2051	Lost data set ready during data wrap.
2027	Interrupt failure; no timer interrupt.	2052	Receive time-out during data wrap.
2028	Interrupt failure; transmit, replace card or planar.	21xx	Alternate binary synchronous communications adapter errors.
2029	Interrupt failure; transmit, replace card.	2110	8255 port A failure.
2030	Interrupt failure; receive, replace card or planar.	2111	8255 port B failure.
2031	Interrupt failure; receive, replace card.	2112	8255 port C failure.
2033	Ring indicate stuck on.	2113	8253 timer 1 did not reach terminal count.
2034	Receive clock stuck on.	2114	8253 timer 1 stuck on.
2035	Transmit clock stuck on.	2115	8253 timer 2 did not reach terminal count or timer 2 stuck on.
2036	Test indicate stuck on.	2117	8251 Data set ready failed to come on.
2037	Ring indicate stuck on.	2118	8251 Clear to send not sensed.
2038	Receive clock not on.	2119	8251 Data set ready stuck on.
2039	Transmit clock not on.	2120	8251 Clear to send stuck on.
2040	Data set ready not on.	2121	8251 hardware reset failure.
		2122	8251 software reset failure.

Code	Description	Code	Description
2123	8251 software "error rest" failure.	2149	Transmit data did not equal receive data.
2124	8251 transmit ready did not come on.	2150	8251 deteted overrun error.
2125	8251 receive ready did not come on.	2151	Lost data set ready during data wrap.
2126	8251 could not force "overrun" error status.	2152	Receive time-out during data wrap.
2127	Interrupt failure; no timer interrupt.	22xx	Cluster adapter errors.
2128	Interrupt failure; transmit, replace card or planar.	24xx	Enhanced Graphics Adapter (EGA) errors.
2129	Interrupt failure; transmit, replace card.	24xx	PS/2 System board Video Graphics Array (VGA) errors.
2130	Interrupt failure; receive, replace card or planar.	26xx	XT/370 errors.
2131	Interrupt failure; receive, replace card.	27xx	AT/370 errors.
2133	Ring indicate stuck on.	28xx	3278/79 emulation adapter errors.
2134	Receive clock stuck on.	29xx	Color/graphics printer errors.
2135	Transmit clock stuck on.	30xx	Primary PC network adapter errors.
2136	Test indicate stuck on.	3001	Processor test failure.
2137	Ring indicate stuck on.	3002	ROM checksum test failure.
2138	Receive clock not on.	3003	Unit ID PROM test failure.
2139	Transmit clock not on.	3004	RAM test failure.
2140	Test indicate not on.	3005	Host interface controller test failure.
2141	Data set ready not on.	3006	+/- 12 V test failure.
2142	Carrier detect not on.	3007	Digital loopback test failure.
2143	Clear to send not on.	3008	Host detected host interface controller failure.
2144	Data set ready stuck on.	3009	Sync failure and no Go bit.
2145	Carrier detect stuck on.	3010	Host interface controller test ok and no go bit.
2146	Clear to send stuck on.	3011	Go bit and no command 41.
2147	Unexpected transmit interrupt.	3012	Card not present.
2148	Unexpected receive interrupt.	3013	Digital failure; fall through.

Code	Description	Code	Description
3015	Analog failure.	73xx	3.5-inch external disk drive errors.
3041	Hot carrier; not this card.	7306	Disk changeline function failure; drive error.
3042	Hot carrier; this card!	7307	Disk is write protected; drive error.
31xx	Secondary PC network adapter errors.	7308	Bad command; drive error.
3101	Processor test failure.	7310	Disk initialization failure; track 0 bad.
3102	ROM checksum test failure.	7311	Time-out; drive error.
3103	Unit ID PROM test failure.	7312	Bad controller chip.
3104	RAM test failure.	7313	Bad direct memory access; drive error.
3105	Host interface controller test failure.	7314	Bad direct memory access; boundary overrun.
3106	+/- 12 V test failure.	7315	Bad index timing; drive error.
3107	Digital loopback test failure.	7316	Drive speed error.
3108	Host detected host interface controller failure.	7322	Bad cyclic redundancy check; drive errors.
3109	Sync failure and no Go bit.	7323	Record not found; drive error.
3110	Host interface controller test OK and no go bit.	7324	Bad address mark; drive error.
3111	Go bit and no Command 41.	7325	Bad controller chip; seek error.
3112	Card not present.	74xx	IBM PS/2 Display adapter (VGA card) errors.
3113	Digital failure; fall through.	85xx	IBM Expanded memory adapter (XMA) errors.
3114	Analog failure.	86xx	PS/2 pointing device errors.
3115	Hot carrier; not this card.	8601	PS/2 pointing device error.
3142	Hot carrier; this card!	8602	PS/2 pointing device error.
33xx	Compact printer errors.	8603	PS/2 pointing device error or system board failure.
36xx	General purpose interface bus (GPIB) adapter errors.	89xx	Music feature card errors.
38xx	Data acquisition adapter errors.	100xx	PS/2 Multiprotocol adapter errors.
39xx	Professional graphics controller errors.	10002	PS/2 Multiprotocol adapter or serial device error.
71xx	Voice communications adapter errors.		

Code	Description	Code	Description
10006	PS/2 Multiprotocol adapter or serial device error.	10042	PS/2 Multiprotocol adapter or system board error.
10007	PS/2 Multiprotocol adapter or communications cable error.	10056	PS/2 Multiprotocol adapter or system board error.
10008	PS/2 Multiprotocol adapter or serial device error.	104xx	PS/2 ESDI fixed disk errors.
10009	PS/2 Multiprotocol adapter or serial device error.	10480	PS/2 ESDI fixed disk 0 failure.
10012	PS/2 Multiprotocol adapter or system board error.	10481	PS/2 ESDI fixed disk 1 failure.
10018	PS/2 Multiprotocol adapter or system board error.	10482	PS/2 ESDI fixed disk controller failure.
10019	PS/2 Multiprotocol adapter or system board error.	10483	PS/2 ESDI fixed disk controller failure.
		10490	PS/2 ESDI fixed disk 0 error.
		10491	PS/2 ESDI fixed disk 1 error.

**12/S**  
**Schematics**

---

12/S - A

---

An Introduction

---

---

## **12/S - A**

### **An Introduction**

---

Schematics provide invaluable information to repair technicians. The schematics included in this manual give an example of the inner circuitry of various electronic devices.

The schematics were chosen because of their illustrative ability, not due to any defects in the covered device. Schematics to deficient devices were not selected for this manual.

The schematics are reprinted at the permission of the manufacturers. Neither WEKA Publishing nor the manufacturers are responsible for any schematic errors, or any injury sustained to individuals working on a device while using these schematics for guidance.

Please follow proper safety precautions. For safety information, refer to Section “2/3 Safety Procedures.”

**12/S**  
**Schematics**

---

12/S - A

---

An Introduction

---

---



12/S - Cam	Camcorders
12/S - Cam - Pan	Panasonic
12/S - Cam - Pan - PV-602, 4, 10 (Pages 1 - 6)	PV-602, 4, 10

Panasonic PV-602, PV-604 and PV-610 Camcorders

NOTE: MARK "●" IS LEADLESS (CHIP) COMPONENT

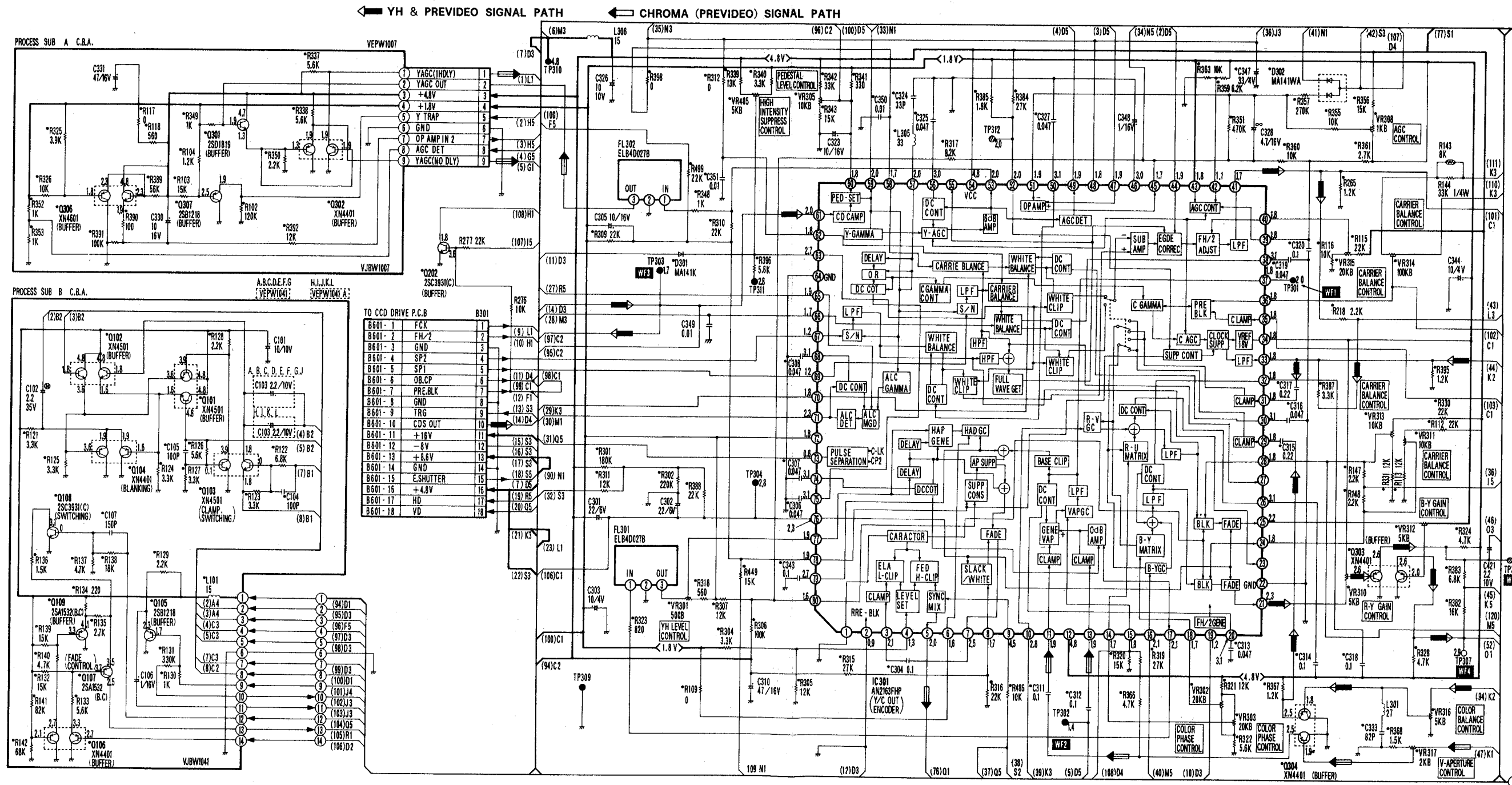
TEST POINT INFORMATION

- : USED FOR THE INDICATION OF TEST POINT WITH NO TEST PIN.
- : USED FOR THE INDICATION OF TEST POINT WITH TEST PIN.

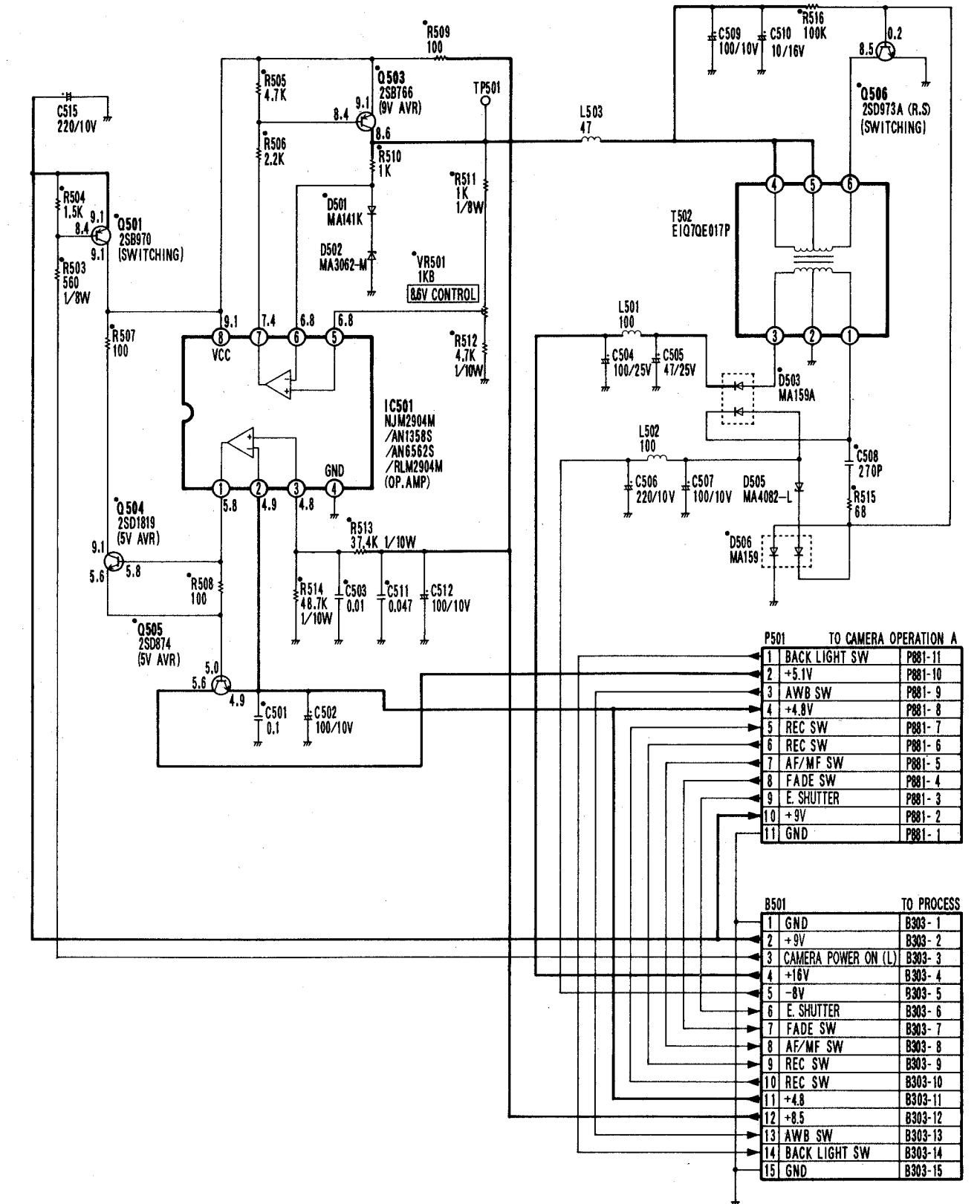
NOTE: MARK "●" IS LEADLESS (CHIP) COMPONENT

NOTE: HOW TO READ CONVERGED LINES

- : LOCATION GRID OF THE OTHER END OF THE LINE
- : LINE NUMBER



PV-602, PV-604 and PV-610 process schematic (I)

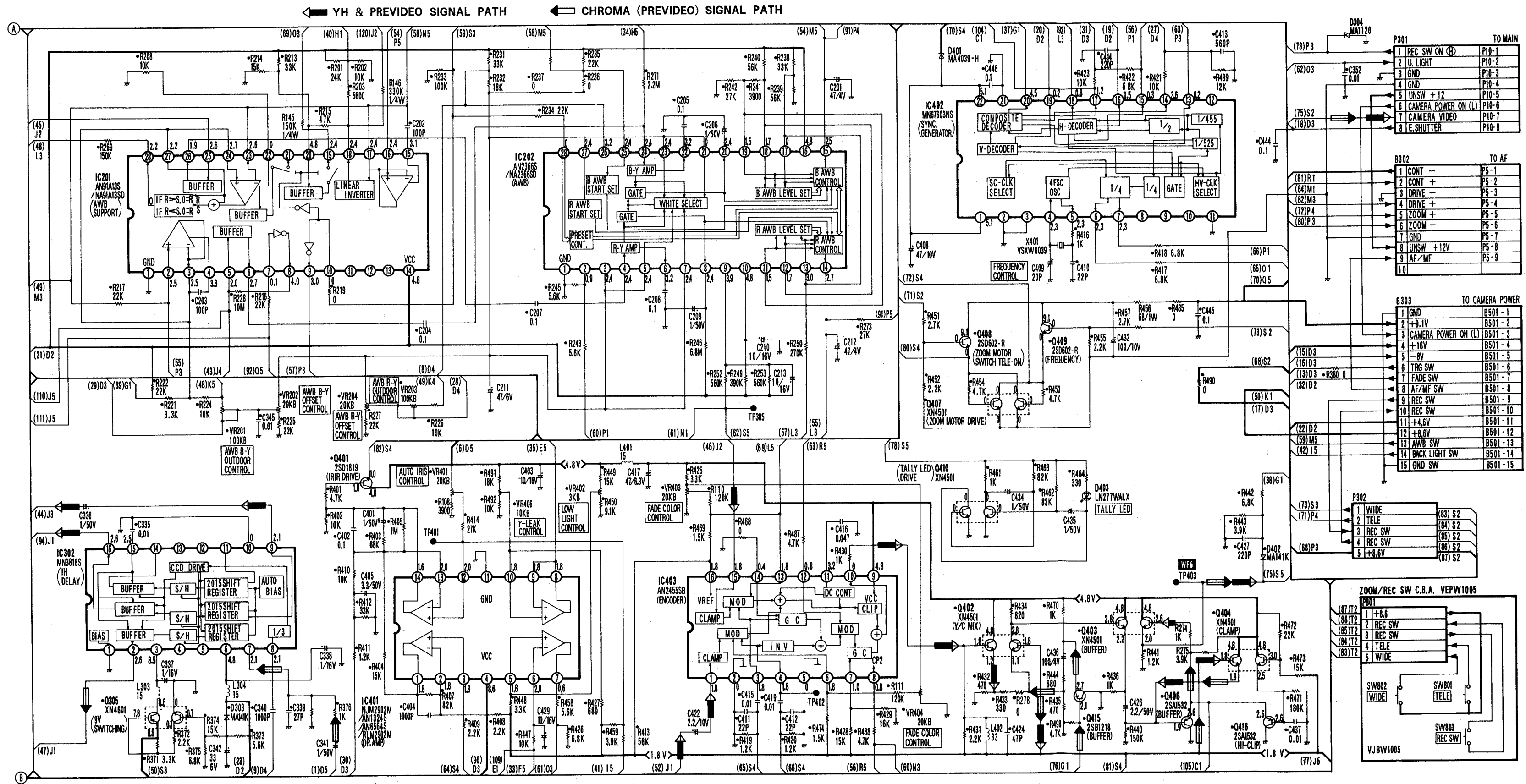


PV-602, PV-604 and PV-610 camera power supply schematic

TEST POINT INFORMATION

- ⊙ : USED FOR THE INDICATION OF TEST POINT WITH NO TEST PIN. NOTE: MARK "•" IS LEADLESS (CHIP) COMPONENT
- : USED FOR THE INDICATION OF TEST POINT WITH TEST PIN.

NOTE: HOW TO READ CONVERGED LINES



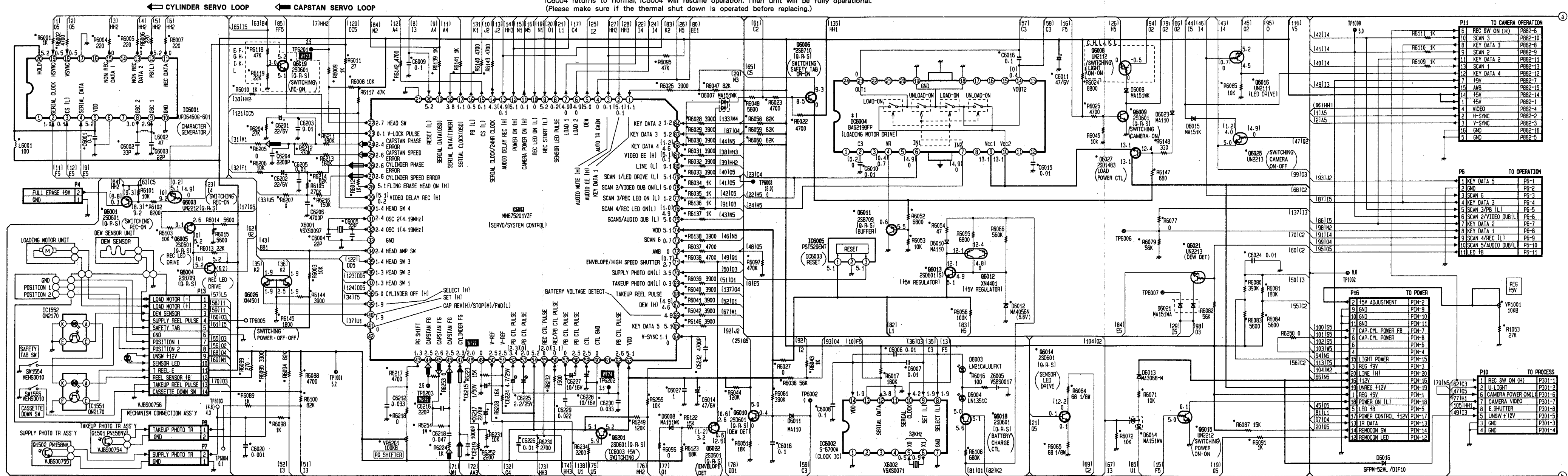
UNLESS OTHERWISE SPECIFIED:  
 WATTAGE OF RESISTORS ARE 1/16W.

TEST POINT INFORMATION

- : USED FOR THE INDICATION OF TEST POINT WITH NO TEST PIN.
- : USED FOR THE INDICATION OF TEST POINT WITH TEST PIN.

NOTE: MARK \* IS LEADLESS (CHIP) COMPONENT

NOTE: \*1 Loading Motor Drive IC6004 with thermal Shut Down Function  
Loading Motor Drive IC6004 has a thermal shut down function to prevent overheating. Therefore, when the temperature of IC6004 raises for some reason, IC6004 will shut down by itself. And the unit will go to power off due to loading lock detection. However, when the temperature of IC6004 returns to normal, IC6004 will resume operation. Then unit will be fully operational. (Please make sure if the thermal shut down is operated before replacing.)

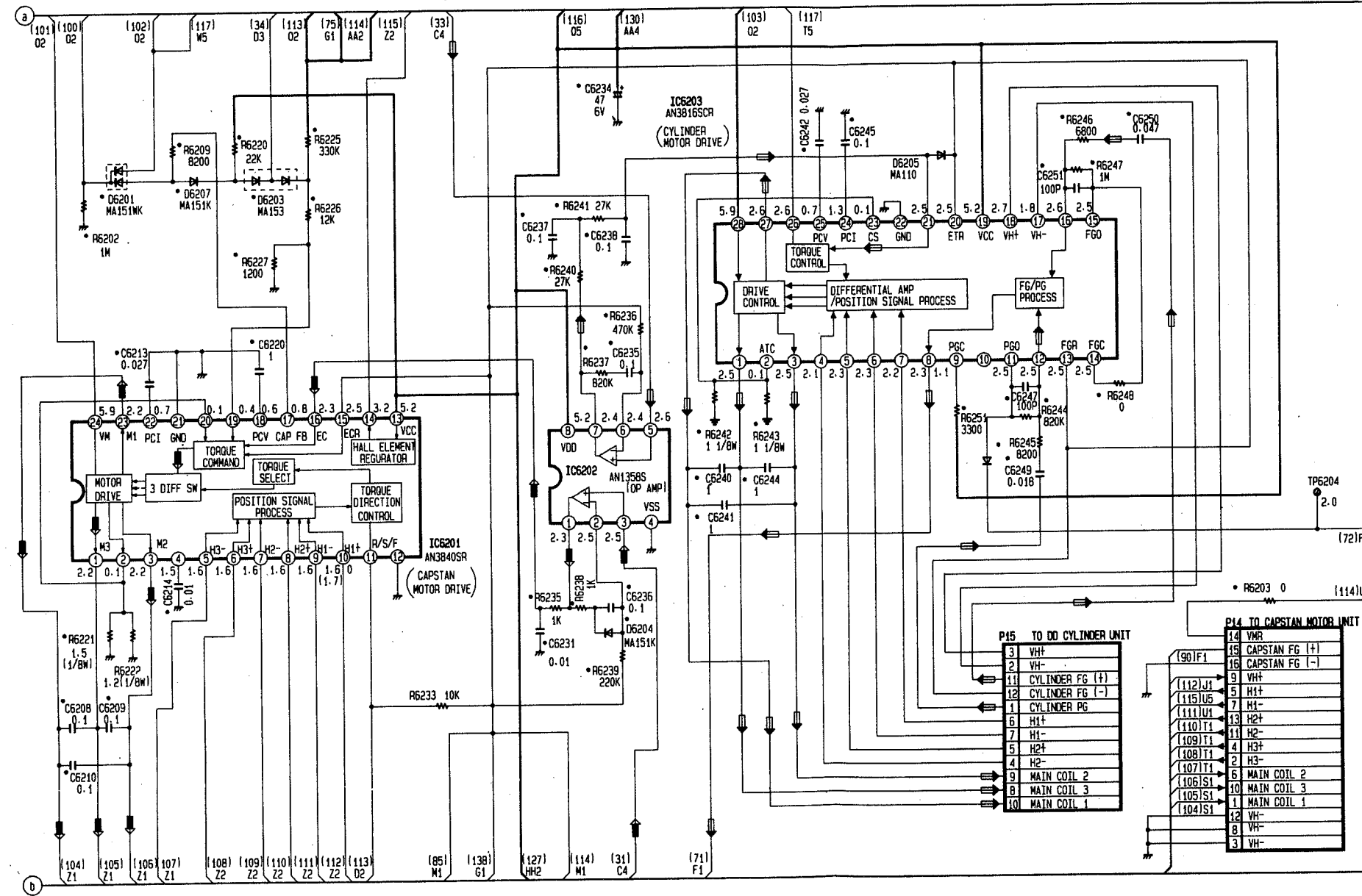


TEST POINT INFORMATION  
 ○ : USED FOR THE INDICATION OF TEST POINT WITH NO TEST PIN.  
 ● : USED FOR THE INDICATION OF TEST POINT WITH TEST PIN.

NOTE: MARK "●" IS LEADLESS (CHIP) COMPONENT

NOTE: HOW TO READ CONVERGED LINES  
 (100) B4  
 ← LOCATION GRID OF THE OTHER END OF THE LINE  
 ← LINE NUMBER

◀ CYLINDER SERVO LOOP    ◀ CAPSTAN SERVO LOOP    ◀ VIDEO REC MODE    ◀ VIDEO PB MODE

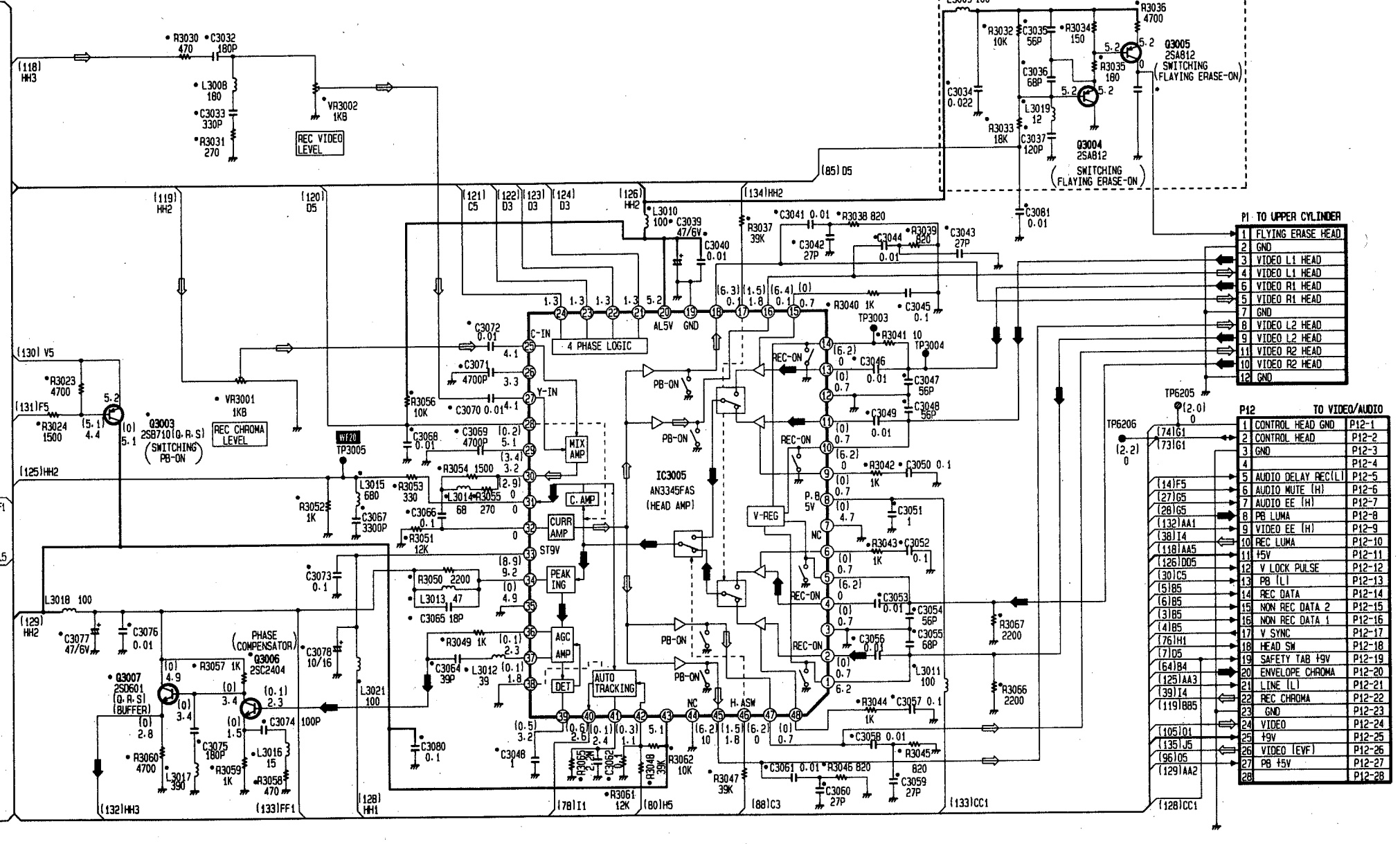


**P15 TO DD CYLINDER UNIT**

3	VH+
2	VH-
11	CYLINDER FG (+)
12	CYLINDER FG (-)
1	CYLINDER PG
6	H1+
7	H1-
10	H2+
4	H2-
9	MAIN COIL 2
8	MAIN COIL 3
10	MAIN COIL 1
12	VH+
8	VH-
3	VH-

**P14 TO CAPSTAN MOTOR UNIT**

14	VHR
15	CAPSTAN FG (+)
16	CAPSTAN FG (-)
9	VH+
5	H1+
11	H1-
13	H2+
11	H2-
4	H3+
10	H3-
6	MAIN COIL 2
10	MAIN COIL 3
1	MAIN COIL 1
10	VH+
10	VH-
3	VH-

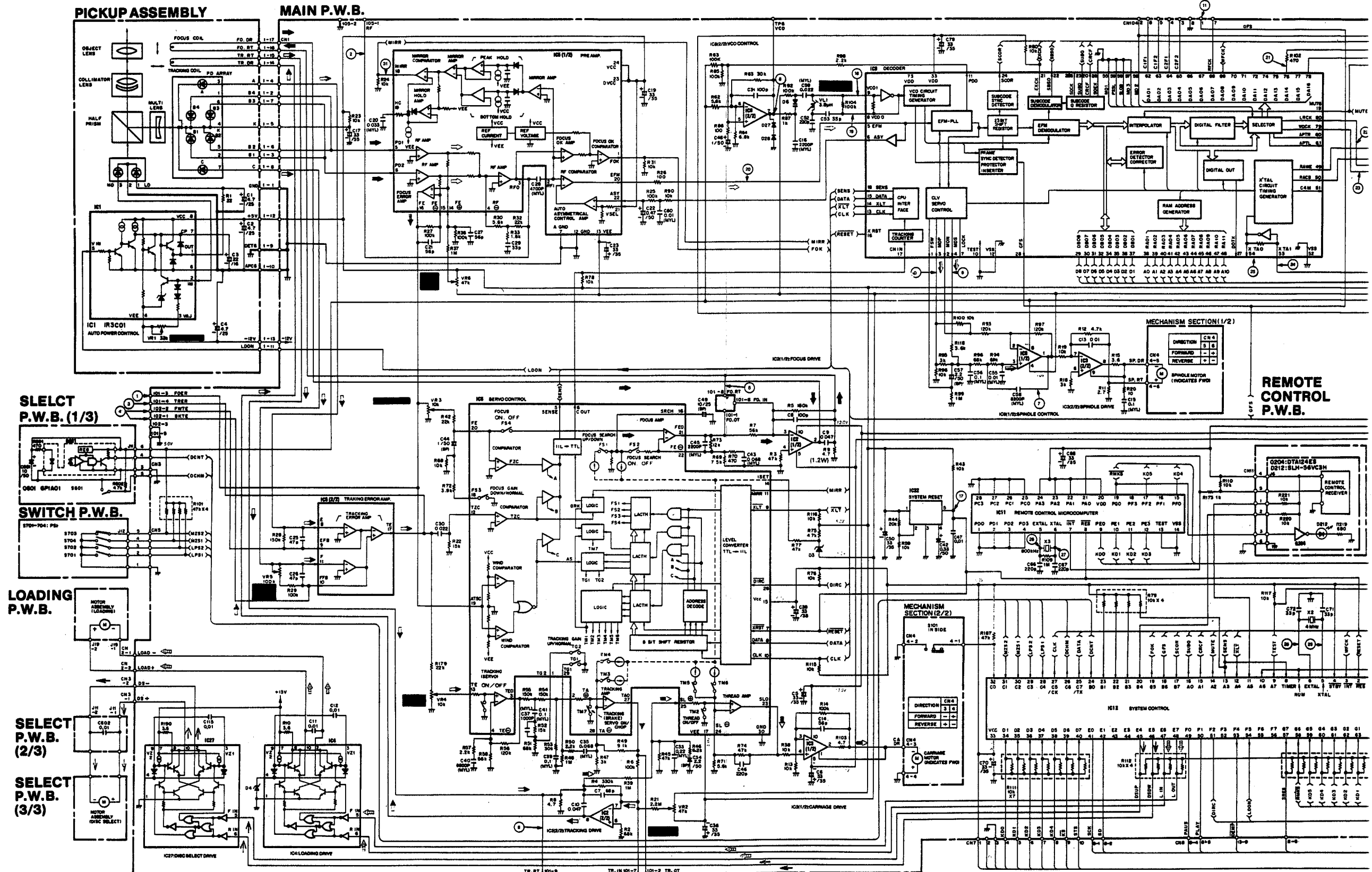


**P1 TO UPPER CYLINDER**

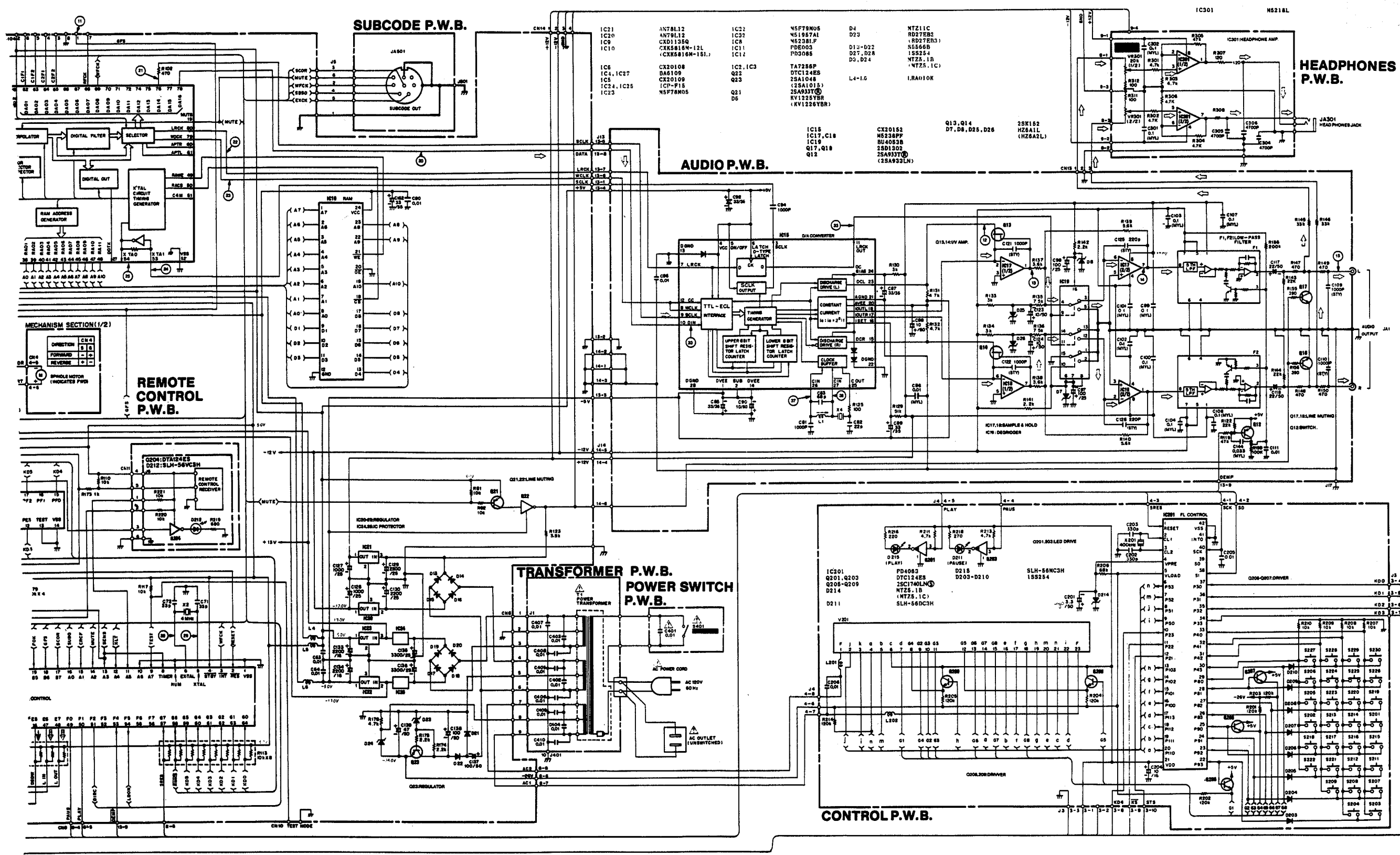
1	FLYING ERASE HEAD
2	GND
3	VIDEO L1 HEAD
4	VIDEO L1 HEAD
5	VIDEO R1 HEAD
6	VIDEO R1 HEAD
7	GND
8	VIDEO L2 HEAD
9	VIDEO L2 HEAD
10	VIDEO R2 HEAD
11	VIDEO R2 HEAD
12	GND

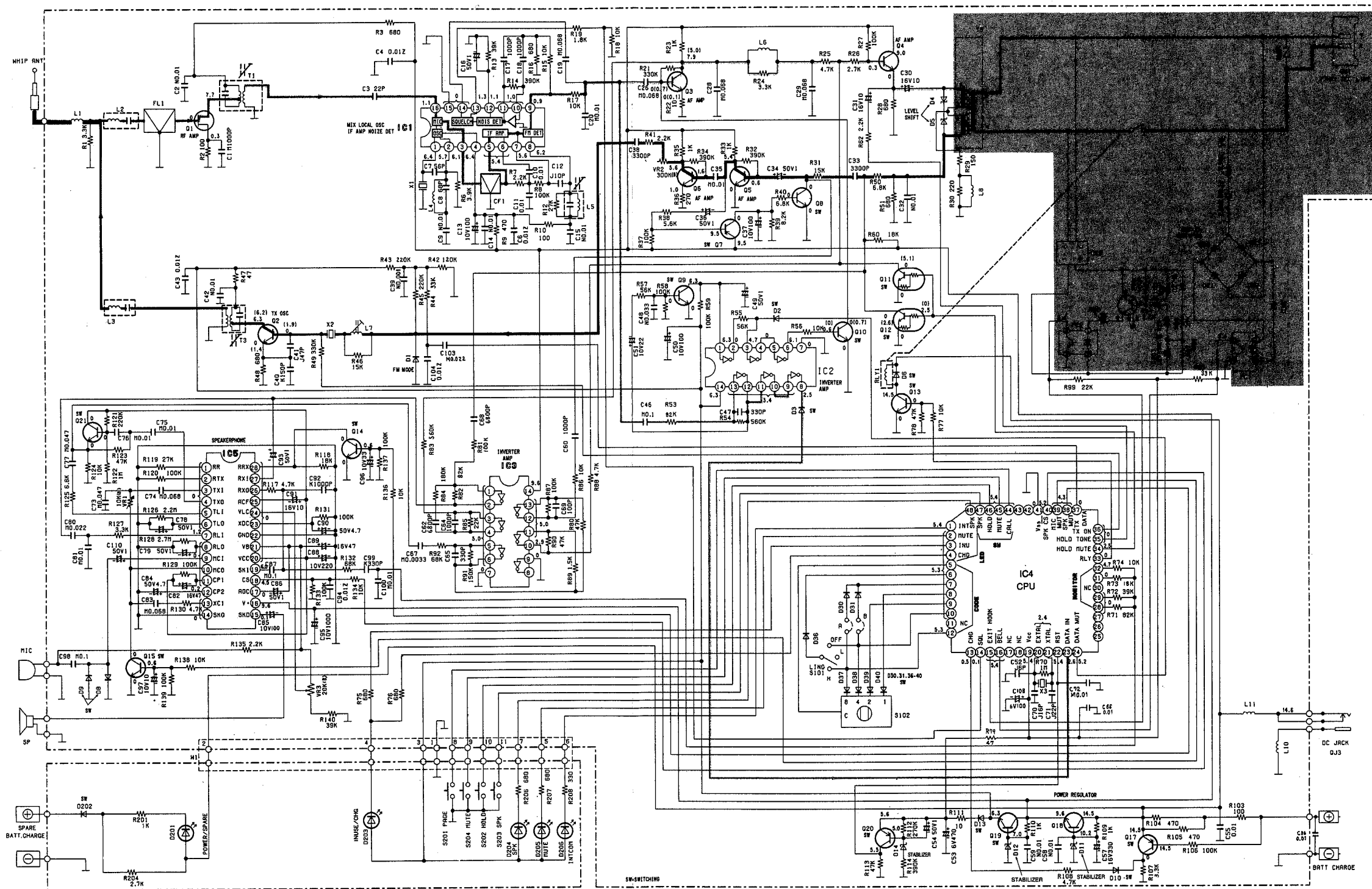
**P12 TO VIDEO/AUDIO**

1	CONTROL HEAD GND	P12-1
2	CONTROL HEAD	P12-2
3	GND	P12-3
4		P12-4
5	AUDIO DELAY REC(L)	P12-5
6	AUDIO MUTE (H)	P12-6
7	AUDIO EE (H)	P12-7
8	PB LUMA	P12-8
9	VIDEO EE (H)	P12-9
10	REC LUMA	P12-10
11	HSV	P12-11
12	V LOCK PULSE	P12-12
13	PB (L)	P12-13
14	REC DATA	P12-14
15	NON REC DATA 2	P12-15
16	NON REC DATA 1	P12-16
17	V SYNC	P12-17
18	HEAD SW	P12-18
19	SAFETY TAB HSV	P12-19
20	ENVELOPE CHROMA	P12-20
21	LINE (L)	P12-21
22	REC CHROMA	P12-22
23	GND	P12-23
24	VIDEO	P12-24
25	HSV	P12-25
26	VIDEO (EWF)	P12-26
27	PB HSV	P12-27
28		P12-28



DA-C60 circuit diagram





Notes:

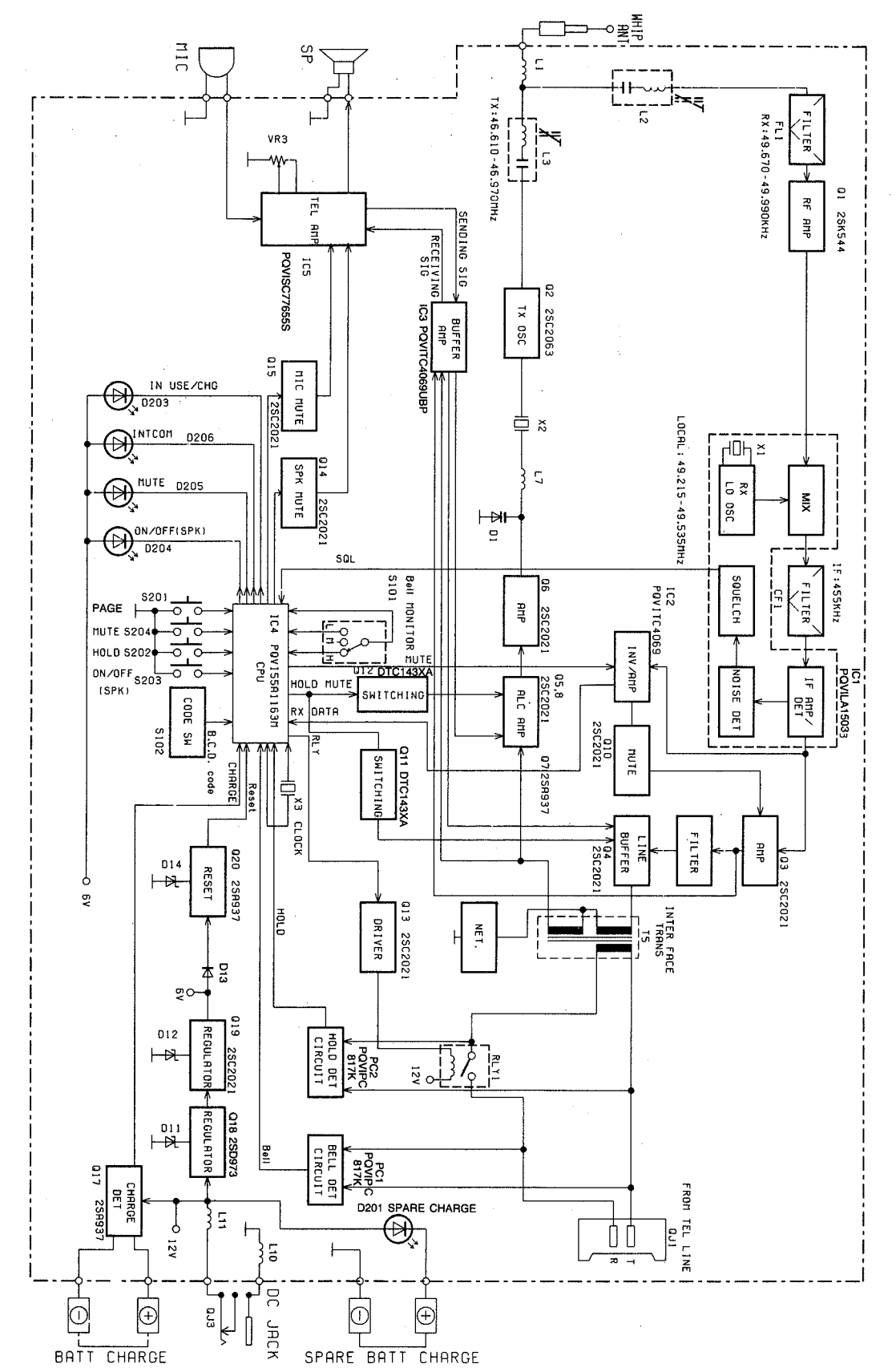
- 1. S102: Code Selector Switch.
- 2. S201: Page/Intercom Switch.
- 3. S202: Hold Switch.
- 4. S203: Speakerphone Switch.
- 5. S204: Mute Switch.
- 6. DC voltage measurements are taken with an electronic voltmeter from the negative voltage line.

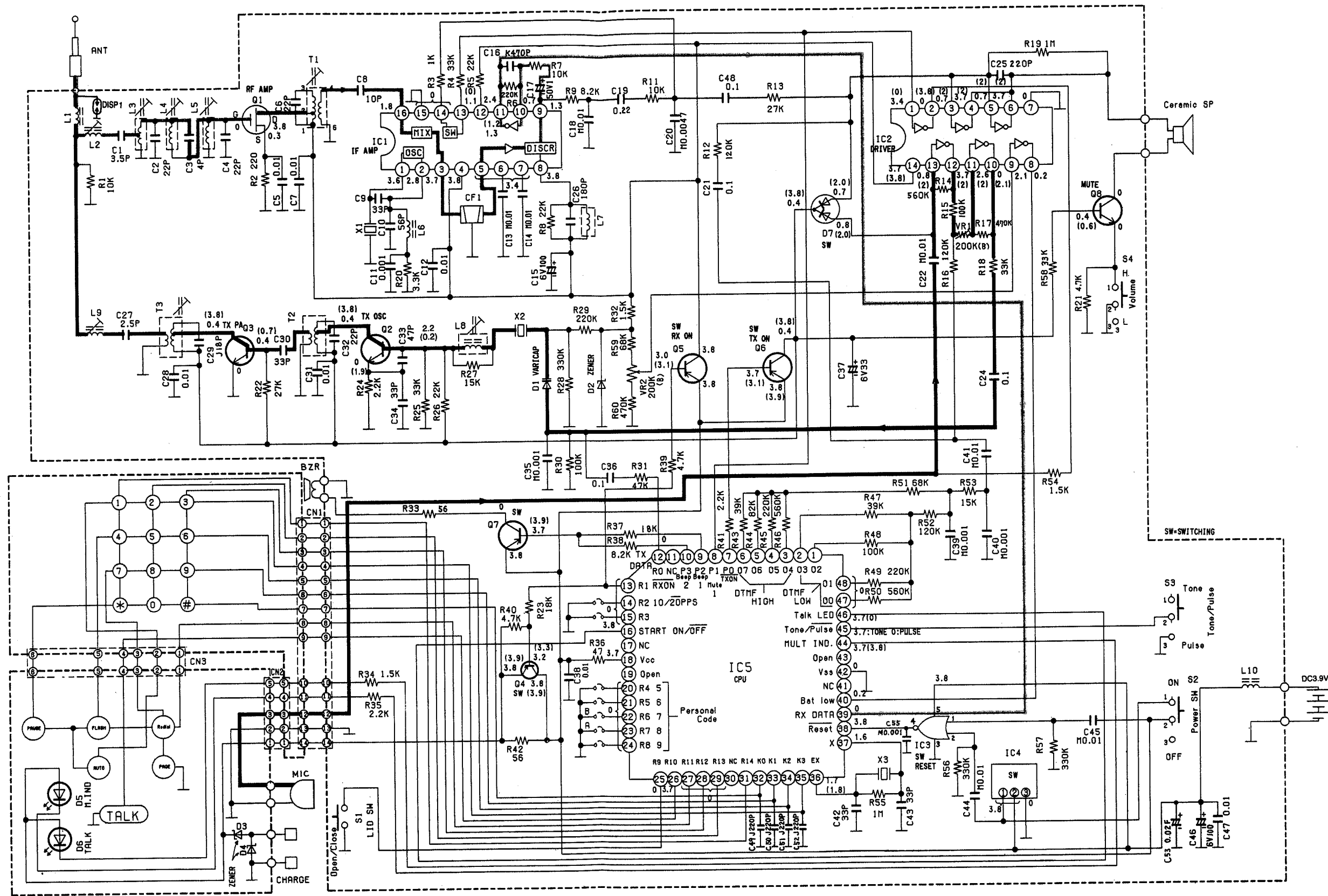
Important Safety notice

The shaded area on this schematic diagram incorporates special features important for protection from fire and electrical shock hazards. When servicing it is essential that only manufacturer's specified parts be used for the critical components in the shaded areas of the schematic.

This schematic diagram may be modified at any time with the development of new technology.

- ← TX Signal
- RX Signal
- ↔ Data Signal

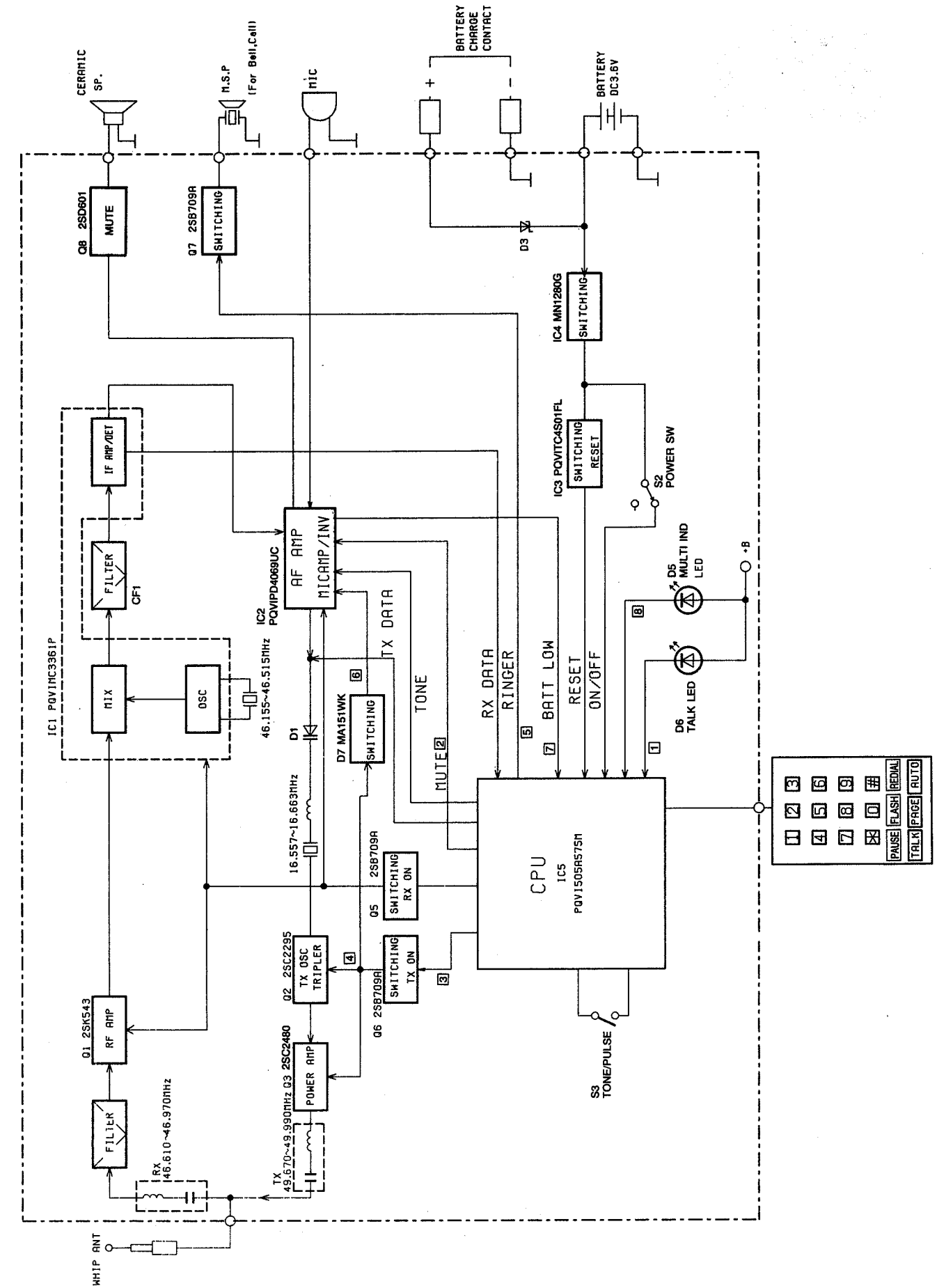
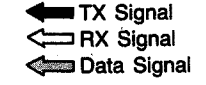




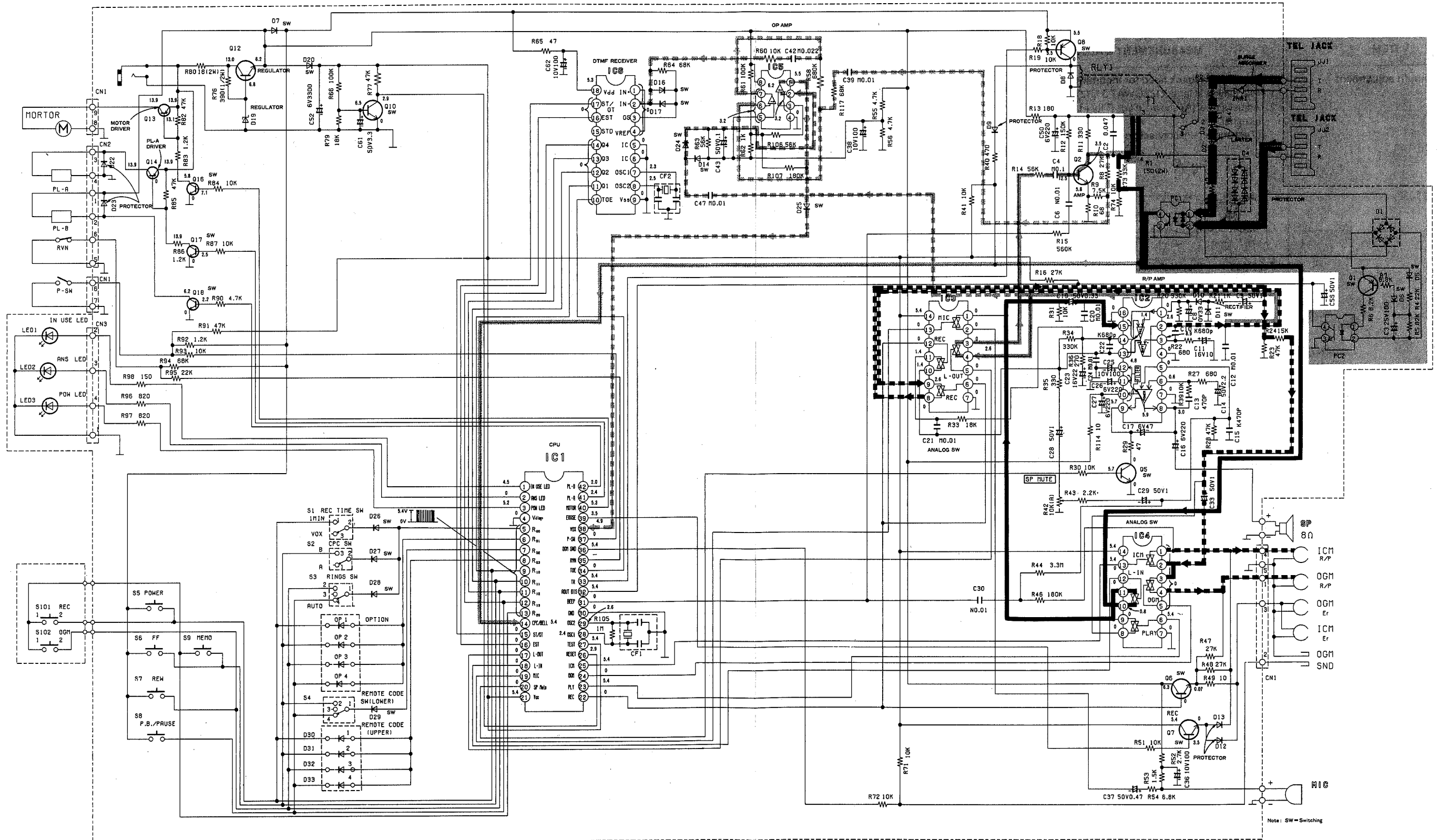
- Notes:
1. S1: Lid Switch.
  2. S2: Power Switch.
  3. S3: Tone/Pulse Selector Switch in "TONE" position.
  4. S4: Volume Selector Switch in "HIGH" position.

5. DC voltage measurements are taken with electronic voltmeters from negative voltage line.  
STANDBY position ( )...TALK position

This schematic diagram may be modified at any time with the development of new technology.







# KX-T2325 Answering Machine

IC1  
PQVIR3N34A  
TONE RINGER

IC2  
MN158342KTA1  
CPU

IC3  
PQVIMB3761M  
COMPARATER

Q1  
2SA1400  
SWITCHING

Q2  
2SD662  
SWITCHING

Q3,5  
2SA937  
SWITCHING

Q4,10,12,20,23  
2SC2021  
SWITCHING

Q17,22  
2SC2021  
AF AMP

Q7  
2SC2120  
AF AMP

Q11,13  
DTA144A  
SWITCHING

Q6,14  
DTC144A  
SWITCHING

Q19,21  
2SD1302  
SWITCHING

D1  
PQVD1G1B42  
RECTIFIER

D2-5  
1SS131  
RECTIFIER

D6  
MA4300  
PROTECTOR

D7  
MA2180  
PROTECTOR

D12,14-22,  
32,42  
1SS131  
SWITCHING

D13  
MA2051  
REGURATOR

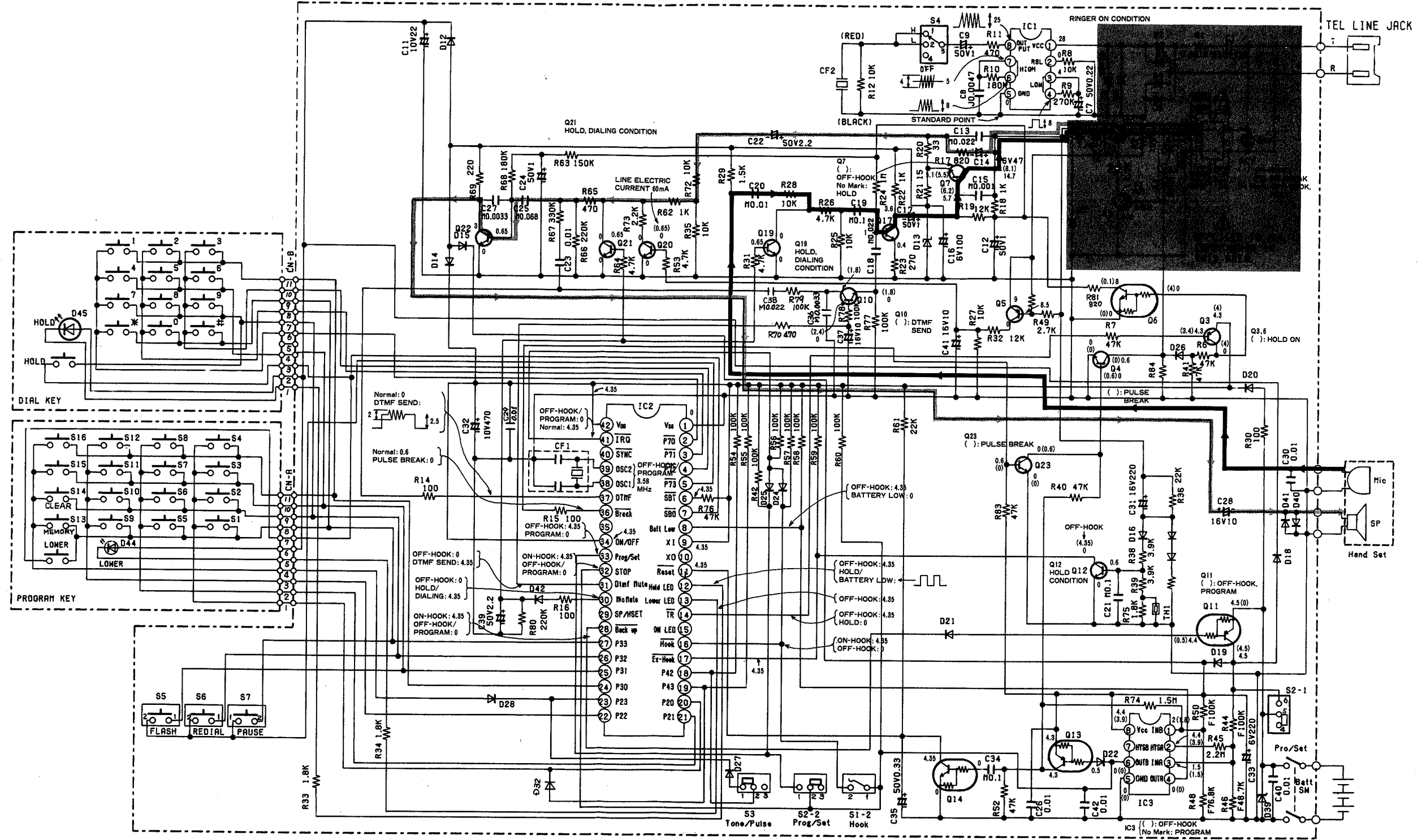
D24-28  
1SS131  
SWITCHING

D30  
MA161  
SWITCHING

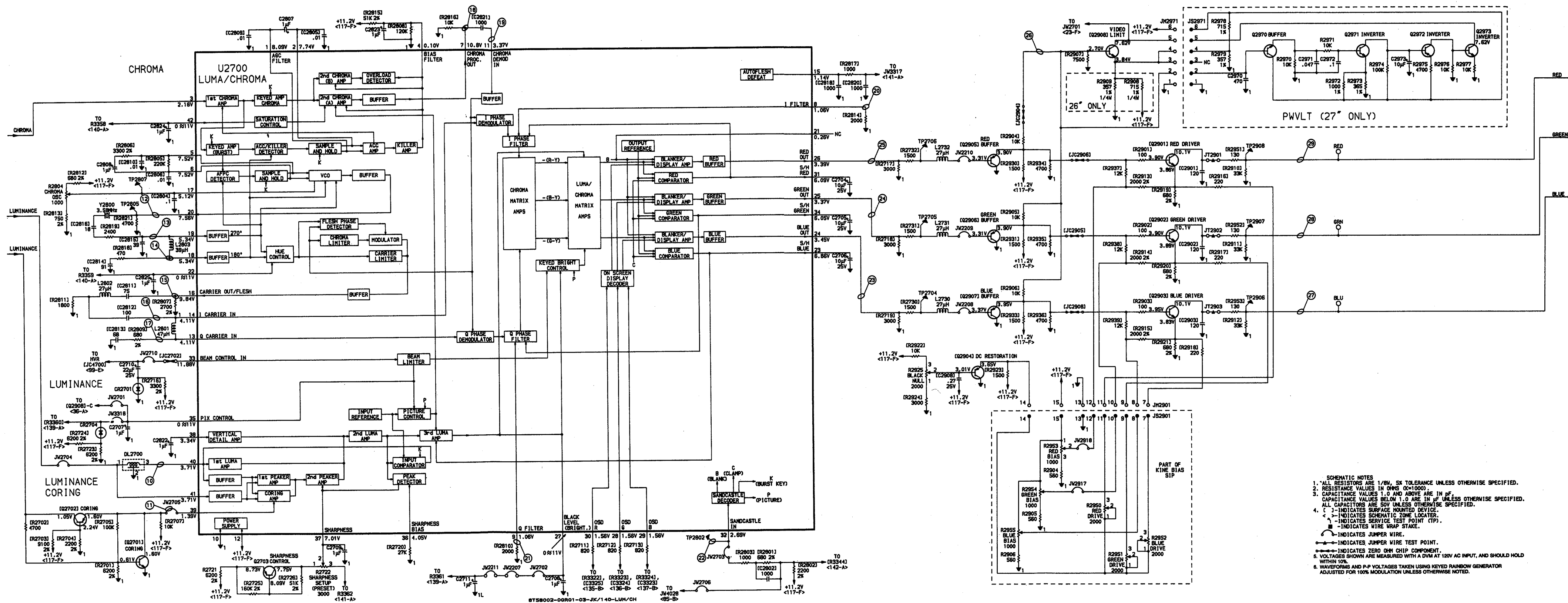
D39  
MA4068  
PROTECTOR

D40,41  
1SS131  
LIMITER

D44  
LN28RPL  
LED

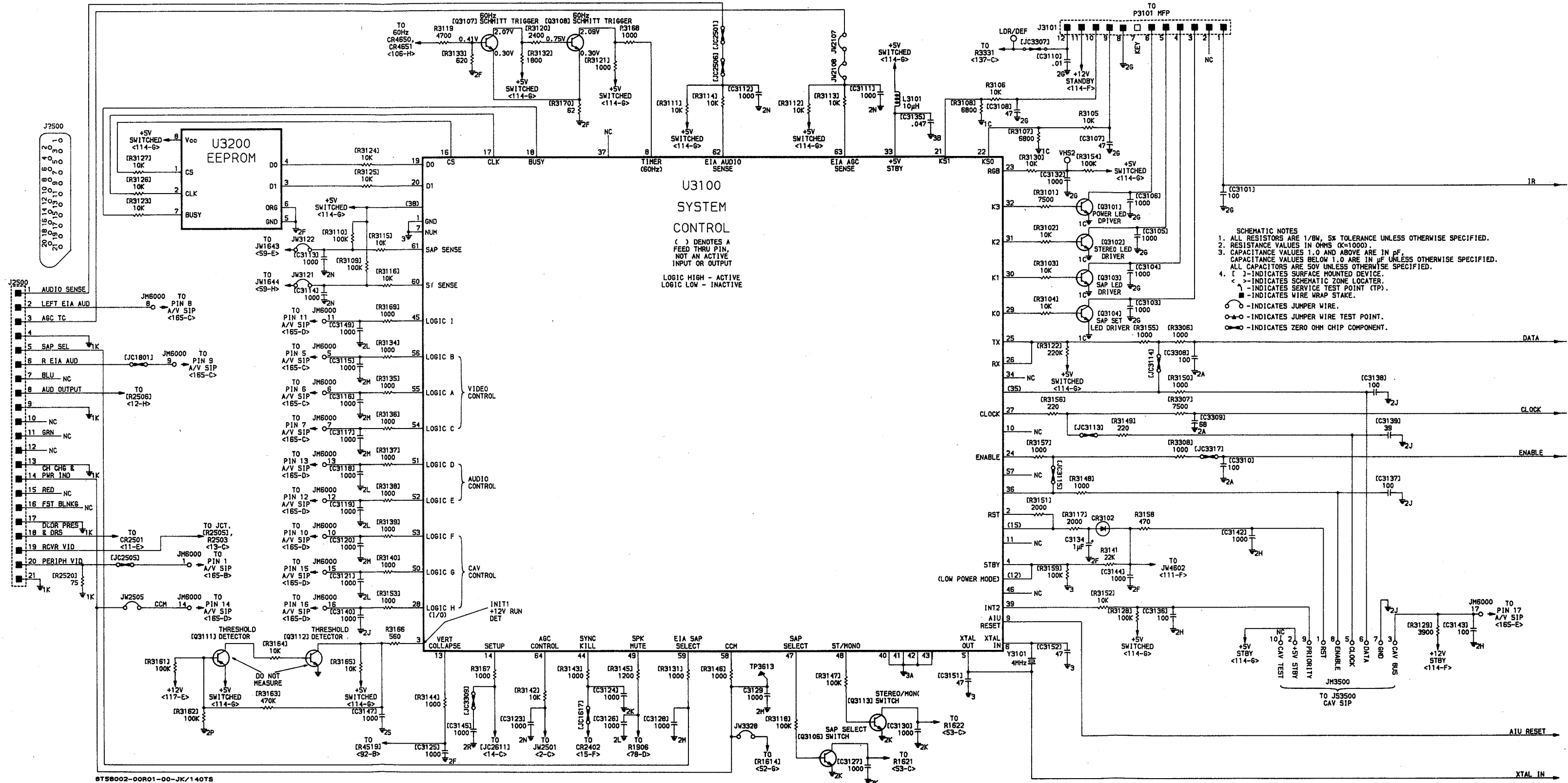






- SCHEMATIC NOTES**
1. ALL RESISTORS ARE 1/8W, 5% TOLERANCE UNLESS OTHERWISE SPECIFIED.
  2. RESISTANCE VALUES IN OHMS (OK1000).
  3. CAPACITANCE VALUES 1.0 AND ABOVE ARE IN  $\mu$ F. CAPACITANCE VALUES BELOW 1.0 ARE IN pF UNLESS OTHERWISE SPECIFIED. ALL CAPACITORS ARE 50V UNLESS OTHERWISE SPECIFIED.
  4. ( ) - INDICATES SURFACE MOUNTED DEVICE.  
 [ ] - INDICATES SCHEMATIC ZONE LOCATOR.  
 \* - INDICATES SERVICE TEST POINT (TP).  
 - - - INDICATES WIRE WRAP STAKE.  
 - - - INDICATES JUMPER WIRE.  
 - - - INDICATES JUMPER WIRE TEST POINT.  
 - - - INDICATES ZERO OHM CHIP COMPONENT.
  5. VOLTAGES SHOWN ARE MEASURED WITH A DVM AT 120V AC INPUT, AND SHOULD HOLD WITHIN 10%.
  6. WAVEFORMS AND P-P VOLTAGES TAKEN USING KEYED RAINBOW GENERATOR ADJUSTED FOR 100% MODULATION UNLESS OTHERWISE NOTED.





12/S Schematics

12/S - VCR

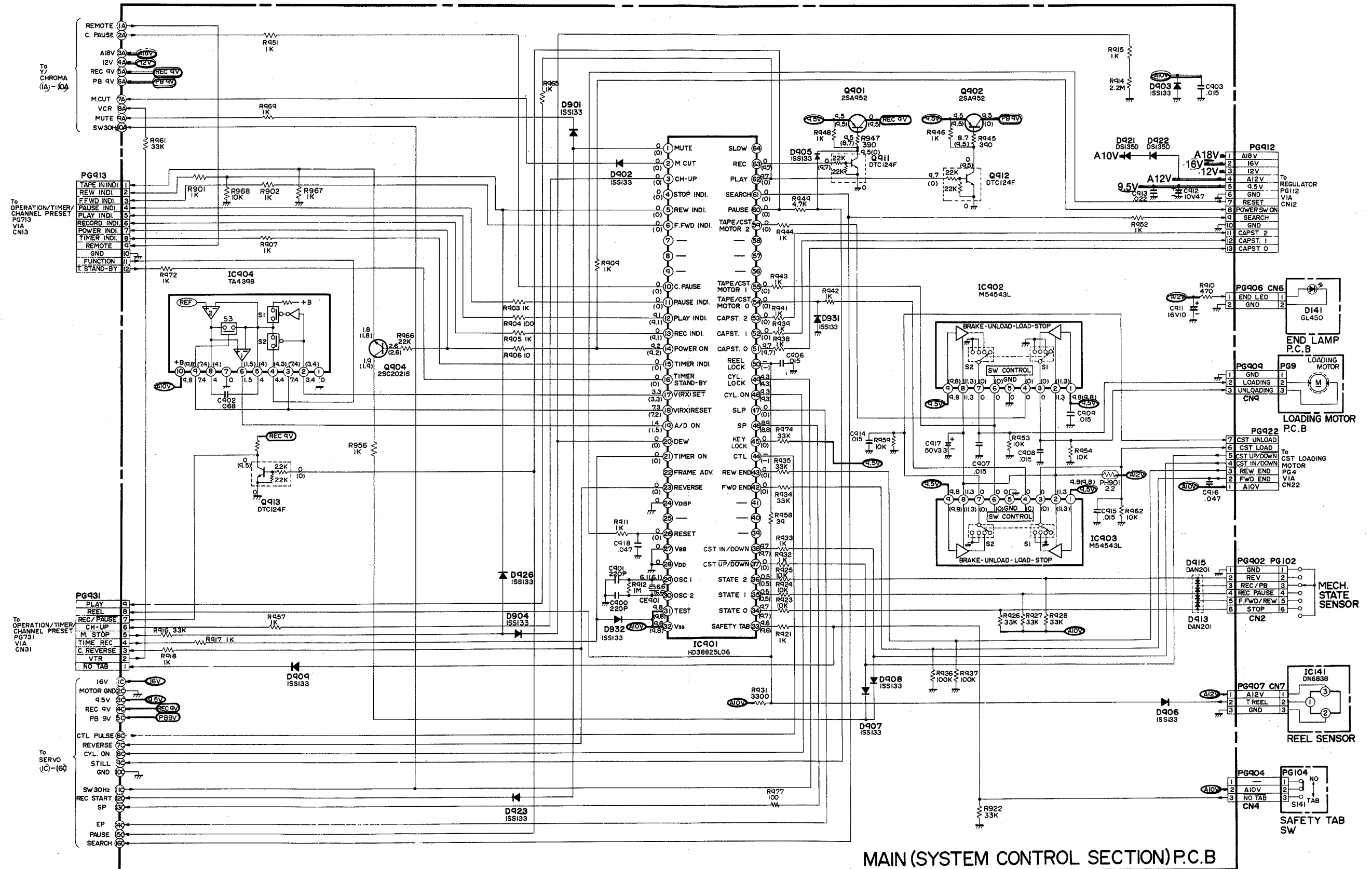
12/S - VCR - Hi

12/S - VCR - HiVT-34A (Pages 1-4)

VCR

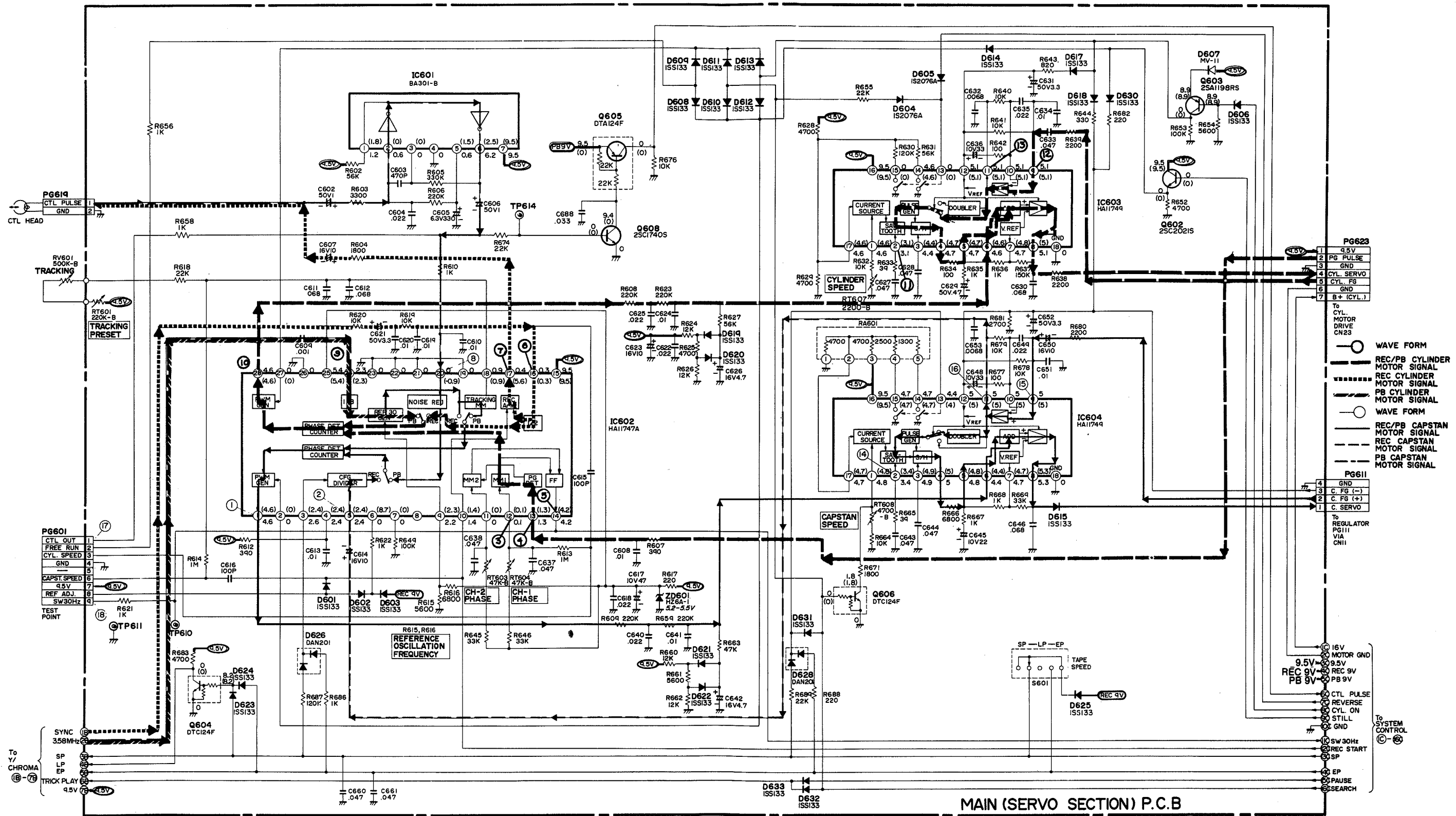
Hitachi

VT-34A



MAIN (SYSTEM CONTROL SECTION) P.C.B

\*VOLTAGES ARE MEASURED IN PLAY MODE, AND VOLTAGES IN ( ) ARE MEASURED IN RECORD MODE.



\* VOLTAGES ARE MEASURED IN PLAY MODE AND VOLTAGES IN ( ) ARE MEASURED IN RECORD MODE.



# 12/S Schematics

## Section 12 • Reference Materials

12/S - VCR

12/S - VCR - Pan

12/S - VCR - Pan - PV-4860, 2; VH5685 (Pages 1-6)

Video Cassette Recorders

Panasonic

PV-4860, 2; VH5685

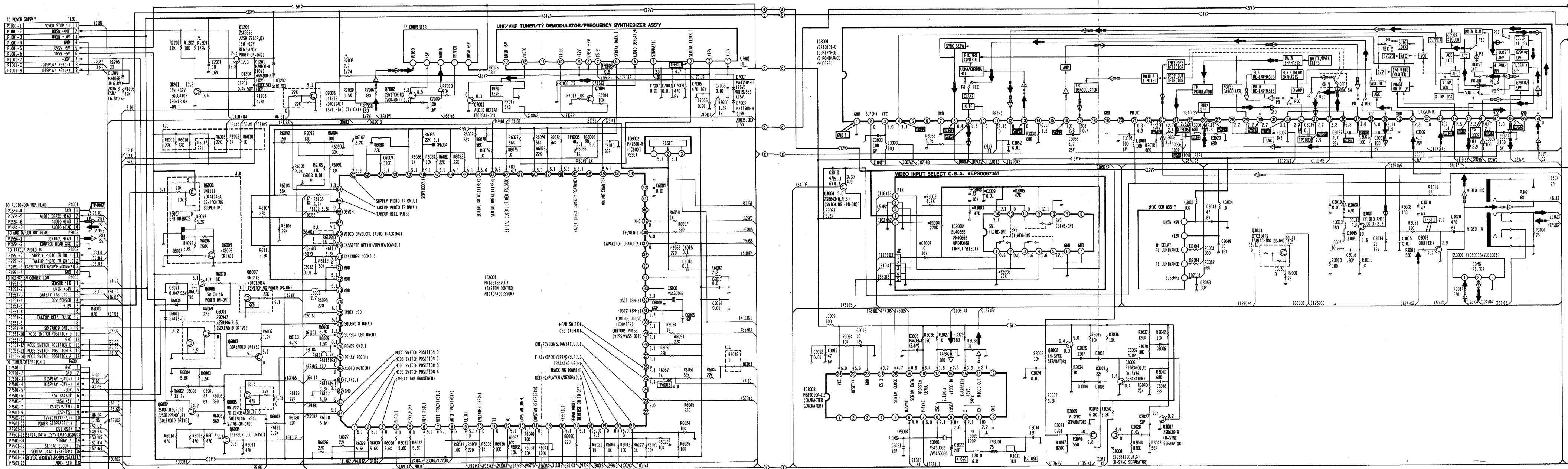
## Panasonic PV-4860, PV-4862 and VH5685 VCRs



NOTE: HOW TO READ CONVERGED LINES (100)B4  
LOCATION GRID OF THE OTHER END OF THE LINE  
LINE NUMBER

IMPORTANT SAFETY NOTICE:  
COMPONENTS IDENTIFIED BY THE SIGN ⚠ HAVE SPECIAL CHARACTERISTICS IMPORTANT FOR SAFETY. WHEN REPLACING ANY OF THESE COMPONENTS, USE ONLY THE SPECIFIED PARTS.

TEST POINT INFORMATION  
●: USED FOR THE INDICATION OF TEST POINT WITH TEST PIN  
○: USED FOR THE INDICATION OF TEST POINT WITH COMPONENT LEAD ON FOIL SIDE AND COMPONENT SIDE  
○: USED FOR THE INDICATION OF TEST POINT WITH COMPONENT LEAD ON FOIL SIDE  
○: USED FOR THE INDICATION OF TEST POINT WITH COMPONENT LEAD ON COMPONENT SIDE  
⊗: USED FOR THE INDICATION OF TEST POINT WITH NO TEST PIN

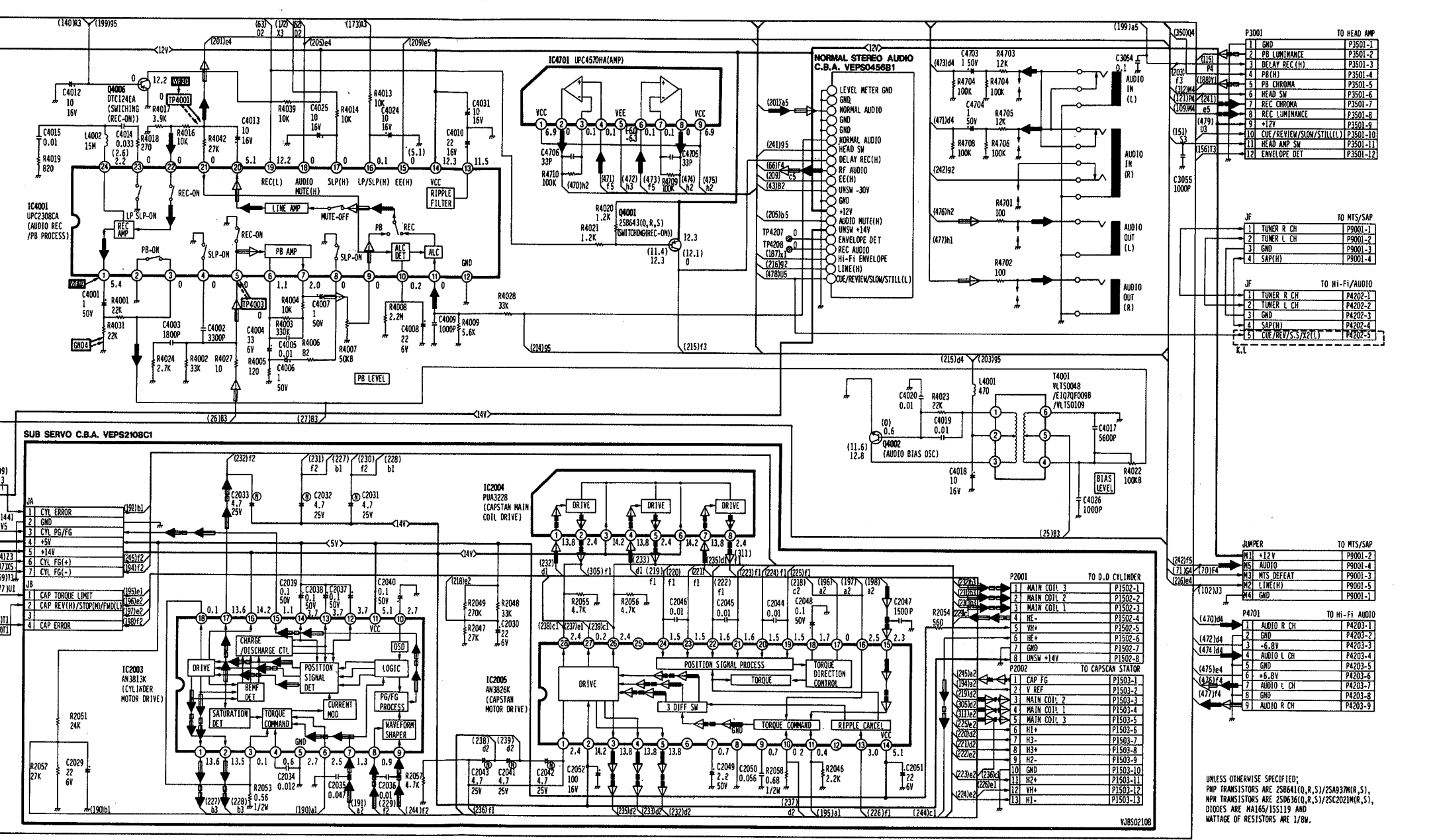
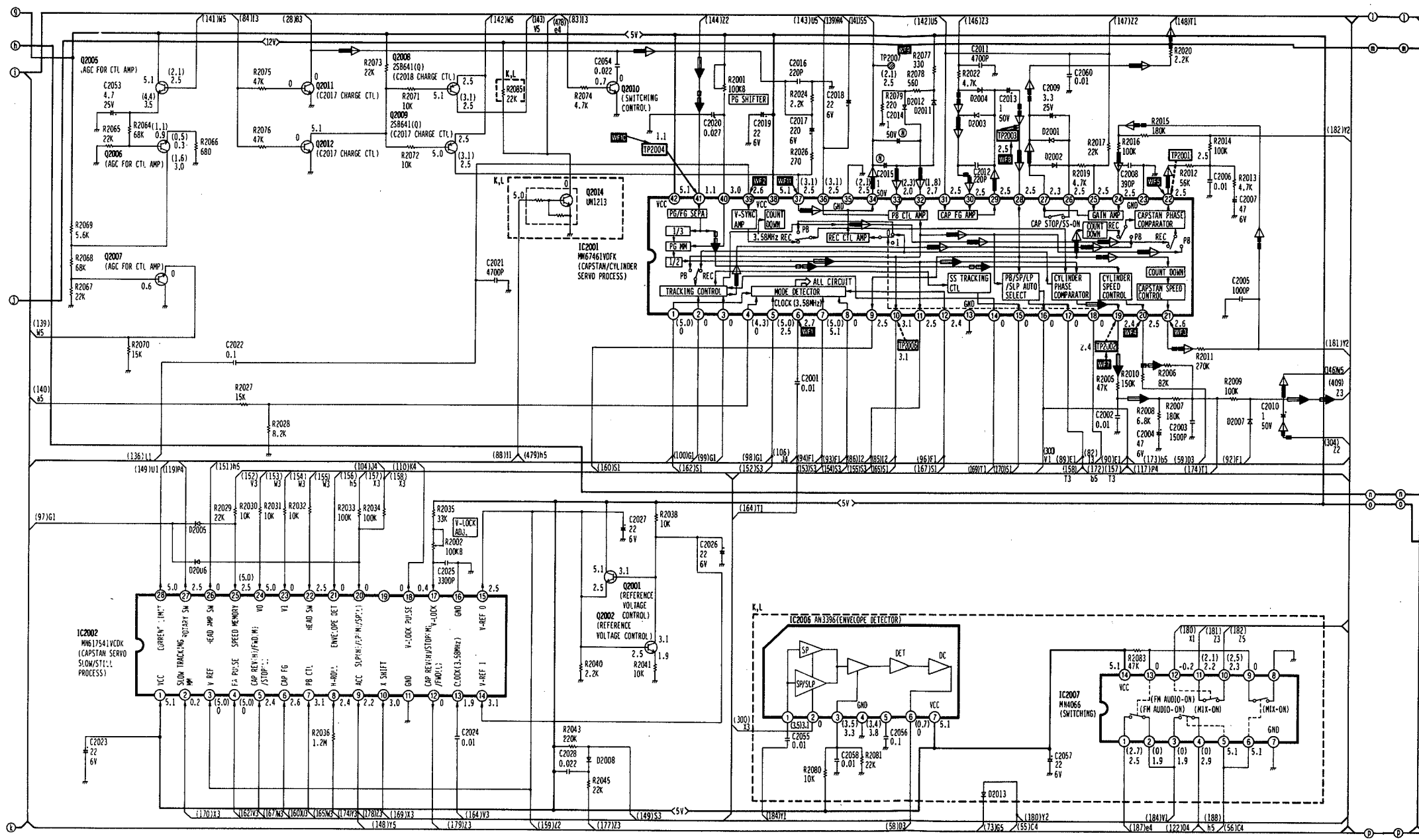


PV-4860, PV4862 and VH5685 system control/signal process/power supply schematic

NOTE: HOW TO READ CONVERGED LINES  
 (100)B4  
 LOCATION GRID OF THE OTHER END OF THE LINE  
 LINE NUMBER

TEST POINT INFORMATION  
 ● USED FOR THE INDICATION OF TEST POINT WITH TEST PIN  
 ○ USED FOR THE INDICATION OF TEST POINT WITH COMPONENT LEAD ON FOIL SIDE AND COMPONENT SIDE  
 ○ USED FOR THE INDICATION OF TEST POINT WITH COMPONENT LEAD ON FOIL SIDE  
 ○ USED FOR THE INDICATION OF TEST POINT WITH COMPONENT LEAD ON COMPONENT SIDE  
 ○ USED FOR THE INDICATION OF TEST POINT WITH NO TEST PIN

VIDEO REC MODE    VIDEO PB MODE    CAPSTAN PHASE LOOP    CAPSTAN SPEED LOOP    CYLINDER PHASE LOOP    CYLINDER SPEED LOOP    AUDIO REC MODE    AUDIO PB MODE



UNLESS OTHERWISE SPECIFIED:  
 PNP TRANSISTORS ARE 2SB641(Q,R,S), 2SC802(M,N,S),  
 NPN TRANSISTORS ARE 2SB646(Q,R,S), 2SC802(M,N,S),  
 DIODES ARE 1N4148, 1N4149 AND  
 WATTAGE OF RESISTORS ARE 1/8W.

**12/S**  
Schematics

12/S - VCR

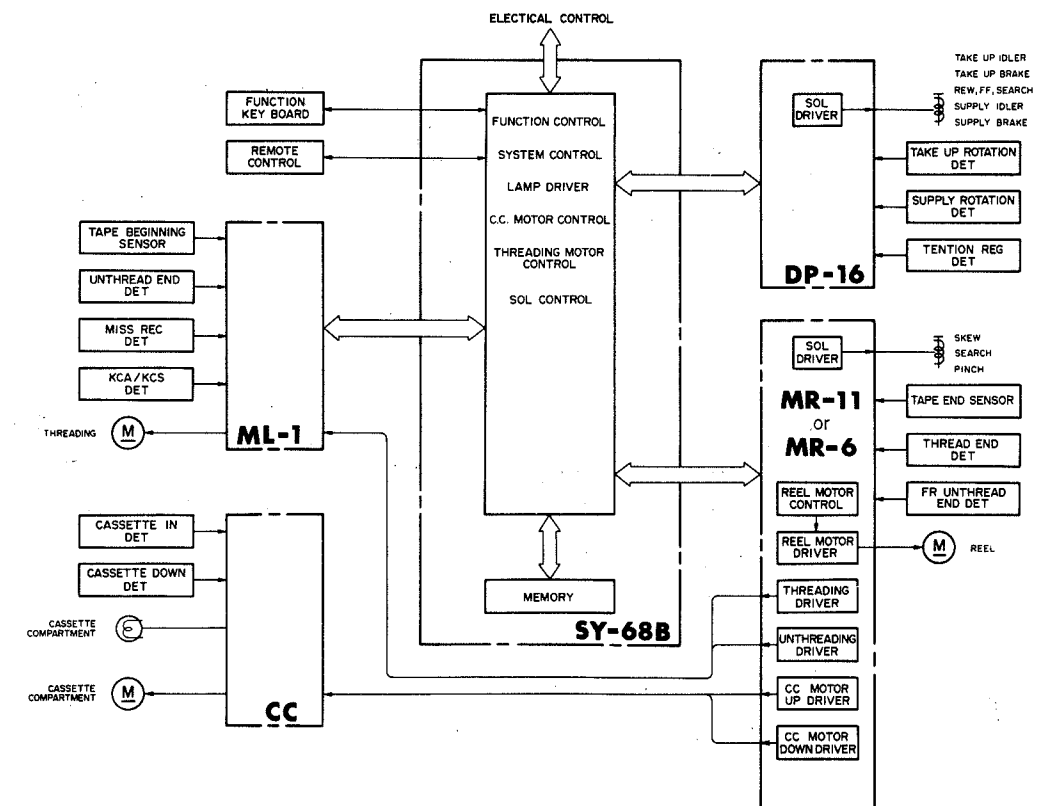
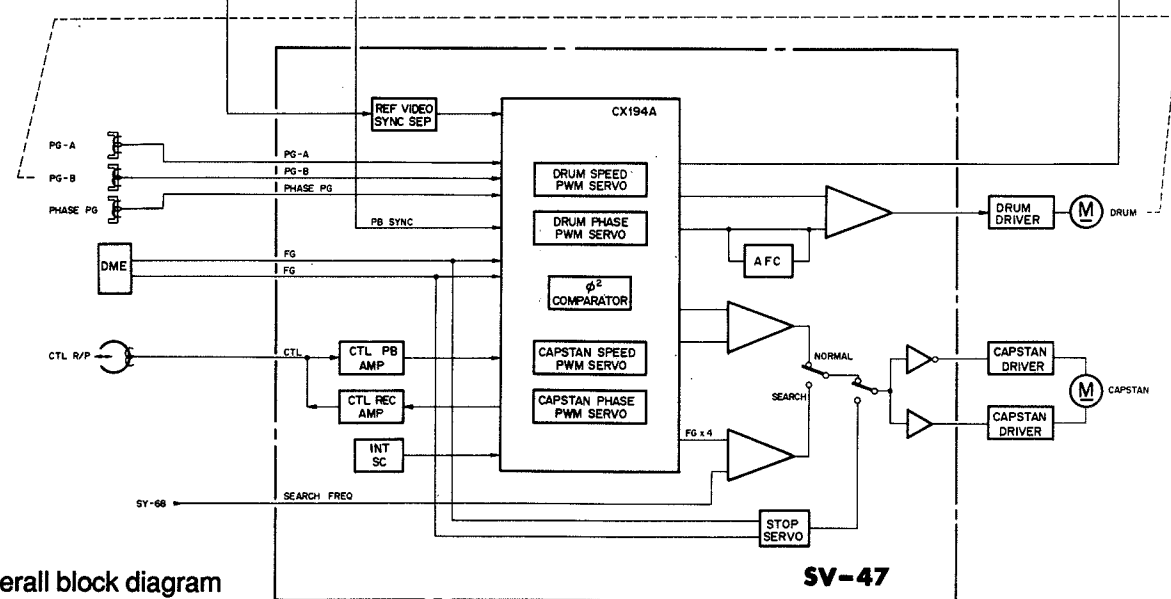
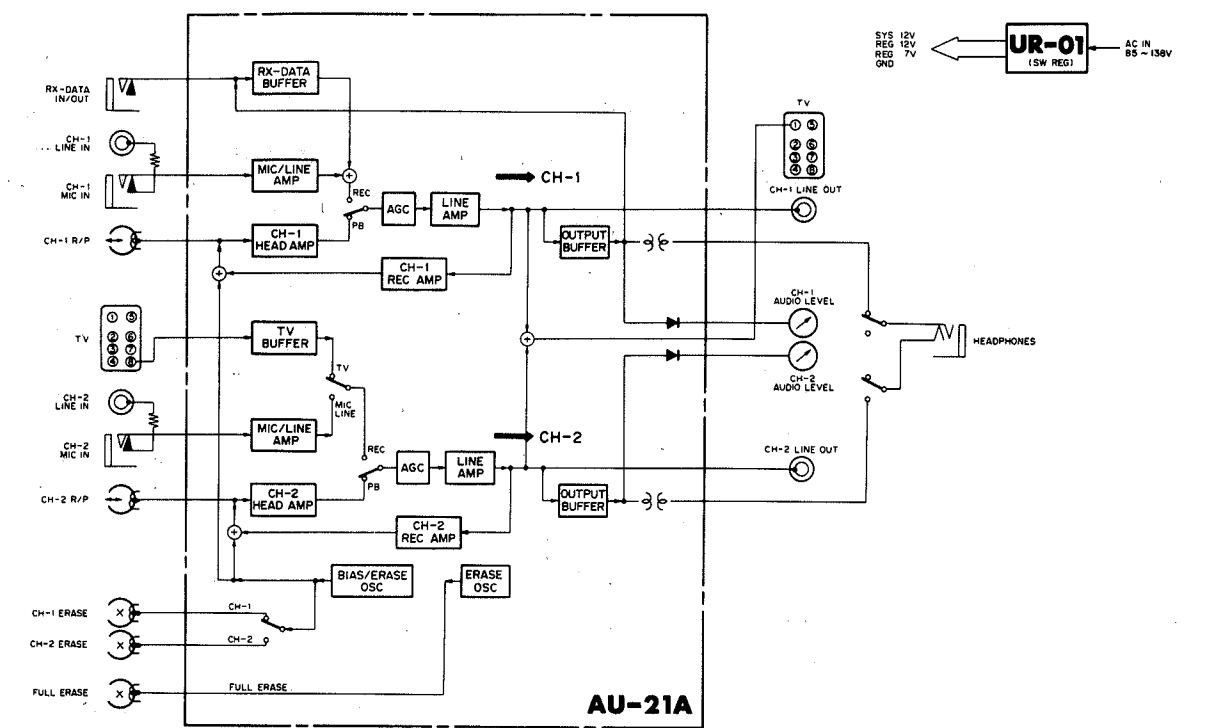
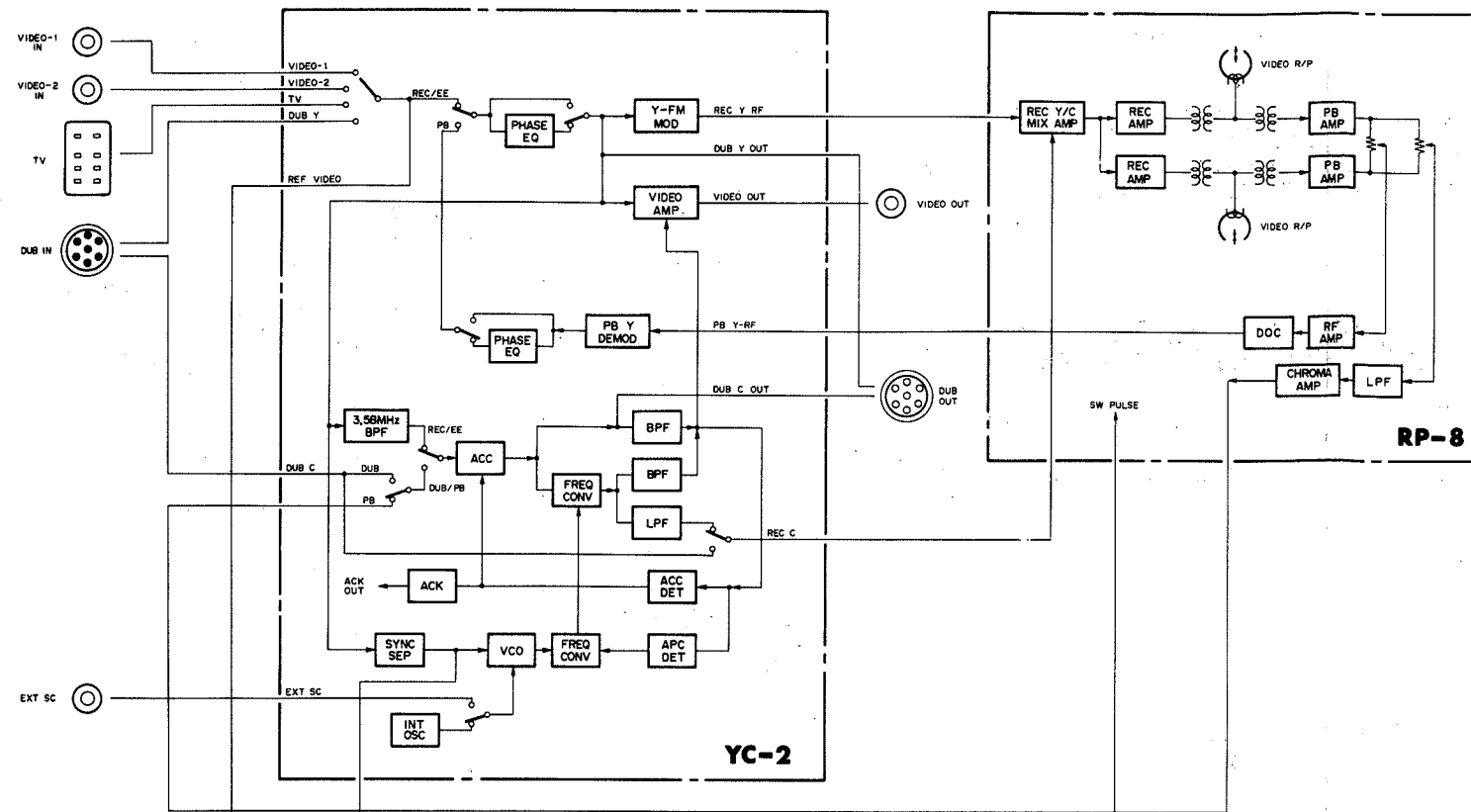
Video Cassette Recorder

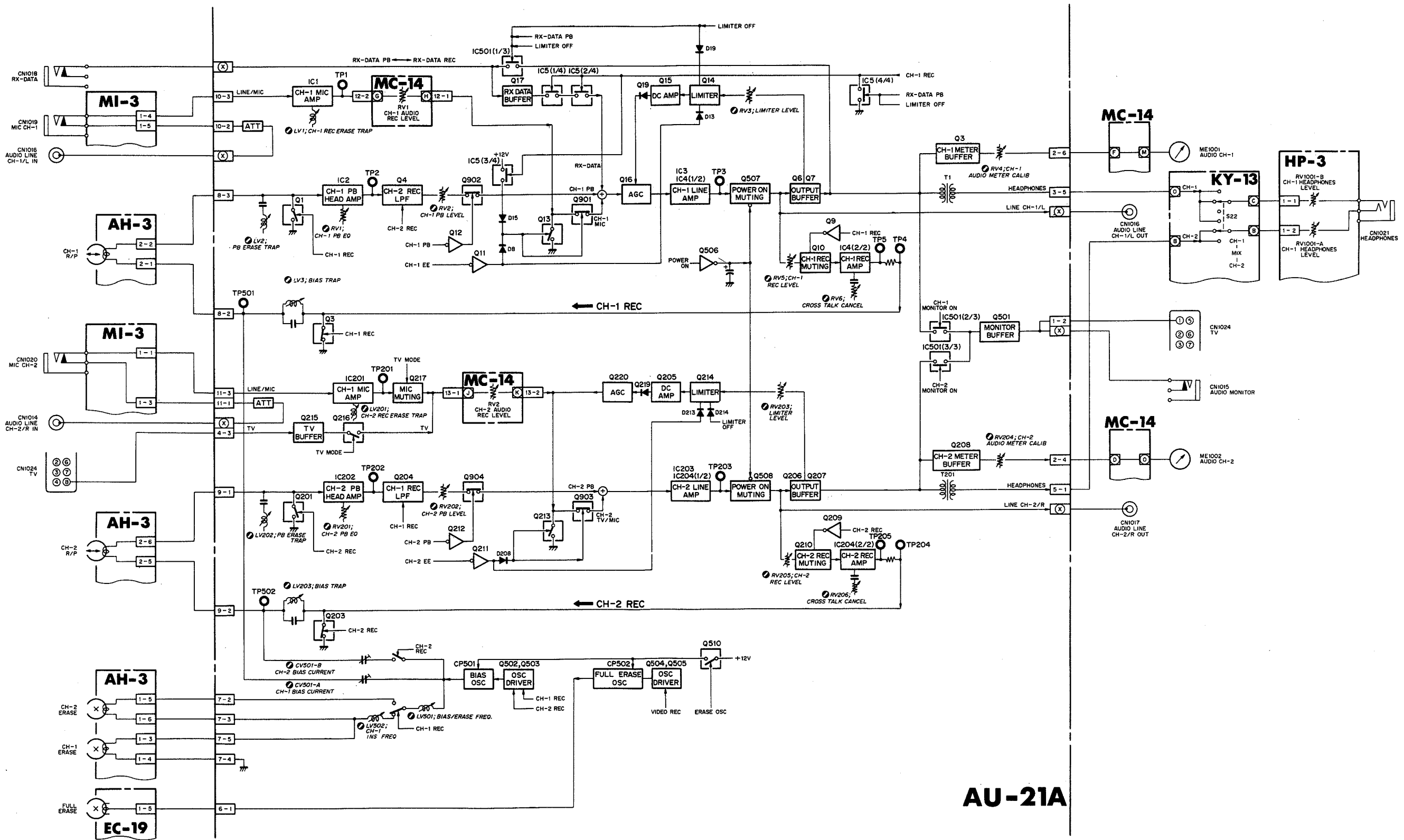
12/S - VCR - SO

Sony

12/S - VCR - SO-VO-5800 (Pages 1 - 4)

VO-5800

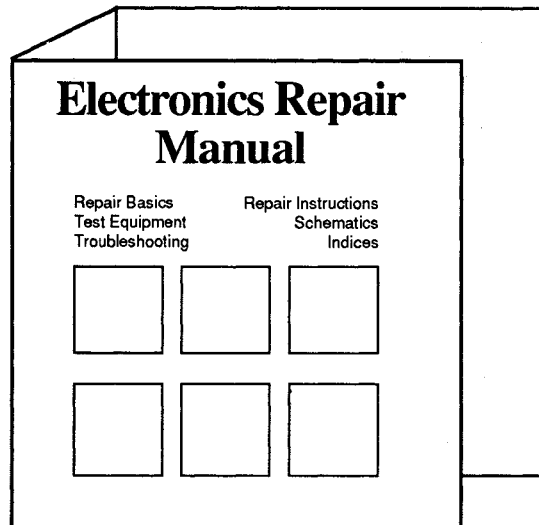




**AU-21A**

# "Electronics Repair Manual" Binder Order

Here's  
how to order  
a new binder for  
your manual



Fill out the coupon below and send it along with your payment of \$8.00. With your next supplement you will receive a new binder for your "Electronics Repair Manual". If you would like to receive the binder immediately, please add \$3.50 shipping and handling charges.

**WEKA Publishing, Inc.**  
97 Indian Field Road  
Greenwich, CT 06830

**Phone: 1-800-222-WEKA**  
**In CT: 203-622-4177**  
**Fax: 1-203-622-4187**

---

## Binder Order for "Electronics Repair Manual"

**YES!**

I would like to receive a new binder  
for my "Electronics Repair Manual".

Enclosed is my payment of

- \$8 for delivery with next supplement  
(save \$3.50 shipping and handling)
- \$11.50 for immediate shipment

Name \_\_\_\_\_

Address \_\_\_\_\_

City \_\_\_\_\_ State/Zip \_\_\_\_\_

WEKA Account No. \_\_\_\_\_

Check enclosed       Visa       MasterCard

Card no. \_\_\_\_\_ Exp. date \_\_\_\_\_

Signature \_\_\_\_\_